



# PRODUCT SPECIFICATION

DOCUMENT NO. ENS000166080

DESCRIPTION	DRAWN BY	DESIGNED BY	CHECKED BY	APPROVED BY
TVL 0201 01 7V AA0DG	Anderson	Anderson	IC	Shawn



# TVL 0201 01 7V AA0DG Product Engineering Specification

## 1. Scope

TVL 0201 01 7V AA0DG is a TVS diode designed to protect one power/control line or one low speed signal line from overvoltage hazard of Electrostatic Discharge (ESD).

These interfaces can be used in computer interfaces protection, microprocessors protection, serial and parallel ports protection, control signal lines protection, power lines on PCB protection, latch-up protection. The actual application examples are low speed and VBUS, etc. The ESD protection of TVS meets the immunity standard of IEC 61000-4-2, level 4 (ESD ±25kV air, ±20kV contact discharge).

## 2. Explanation of Part Number

<u>TV</u>	<u>L</u>	<u>0201</u>	<u>01</u>	<u>7V</u>	<u>AA0</u>	<u>DG</u>
(1)	(2)	(3)	(4)	(5)	(6)	(7)

- (1) Product Type : TV=TVS Diode
- (2) Capacitance Code : L=Low Capacitance
- (3) Package Code
- (4) Channel Code : 01=1 Channels
- (5) Working Voltage
- (6) Special code
- (7) Inpaq Control Code

## 3. Circuit Diagram & Dimension

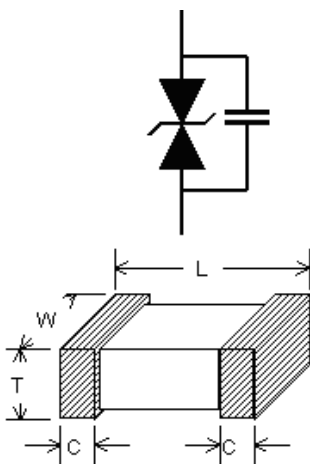

Unit: mm	0201
L	0.60±0.05
W	0.30±0.04
T	0.30±0.04
C	0.20±0.06

## 4. Specifications

### 4.1. Absolute Maximum Ratings

Parameter	Symbol	Rating	Units
Operating Supply Voltage	$V_{DC}$	$\pm 7$	V
Peak Pulse Current (8/20 $\mu$ s)	$I_{PP}$	8	A
Peak Pulse Power(8/20 $\mu$ s)	$P_{PP}$	90	W
ESD per IEC 61000-4-2 (Air)	$V_{ESD}$	$\pm 25$	kV
ESD per IEC 61000-4-2 (Contact)		$\pm 20$	
Lead Soldering Temperature	$T_{SOL}$	260 (20-40 sec.)	$^{\circ}C$
Operating Temperature	$T_{op}$	-55 to +85	$^{\circ}C$

### 4.2. Electrical Characteristics

Parameter	Symbol	Conditions	Min	Typ	Max	Units
Reverse Stand-Off Voltage	$V_{RWM}$	$T=25^{\circ}C$ .	-7		7	V
Reverse Leakage Current	$I_{Leak}$	$V_{RWM} = 7V, T=25^{\circ}C$ .			0.5	$\mu A$
Reverse Breakdown Voltage	$V_{BV}$	$I_{BV} = 1mA, T=25^{\circ}C$ .	7.5	8.8	10.5	V
Clamping Voltage	$V_C$	$I_{TLP} = 1A$ (100ns transmission line) $I_{TLP} = 16A$ (100ns transmission line)		9.2 12.8		
Channel Input Capacitance	$C_{IN}$	$V_R = 0V, f = 1MHz, T=25^{\circ}C$ .		8.5		pF

### 4.3. Typical Characteristics

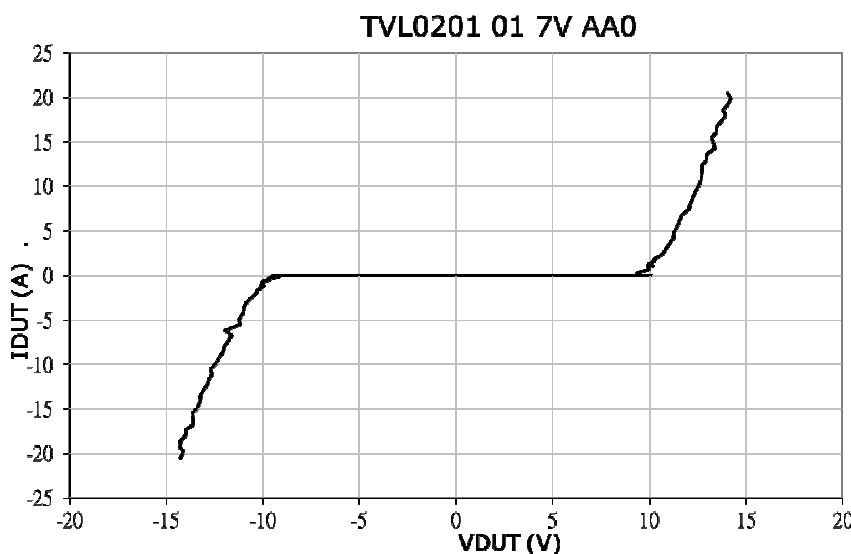

## 5. Taping Package and Label Marking

**5.1. Packaging Method** (Material: paper)

Products shall be heat-sealed in the chip pocket, spacing pitch 4-mm of paper carrier tape with plastic cover tape, and the carrier tape shall be reeled to the reel.

**5.2. Carrier Tape Dimensions**

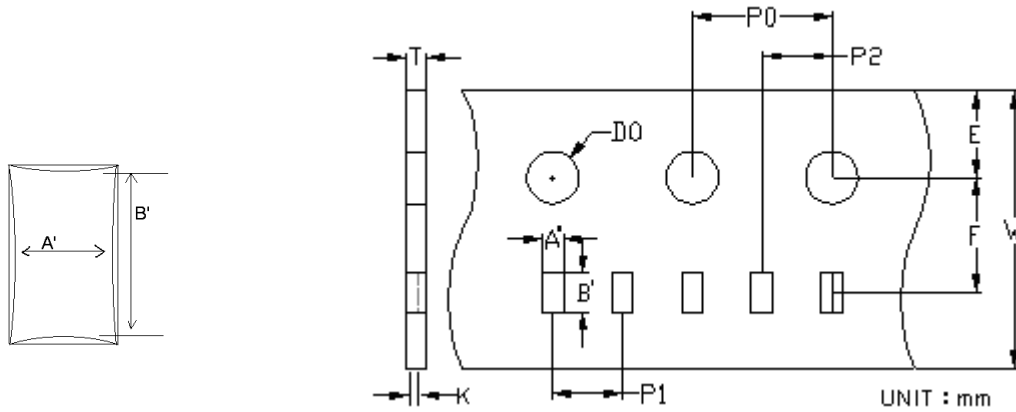

Type	A'	B'	W	E	F	P0	P1	P2	D0	T	K
0201	0.35 ±0.02	0.67 ±0.02	8.0 ±0.1	1.75 ±0.05	3.5 ±0.05	4.0 ±0.03	2.0 ±0.03	2.0 ±0.03	1.55 ±0.05	0.42 ±0.03	0.35 ±0.02

**5.3. Taping Reel Dimensions**

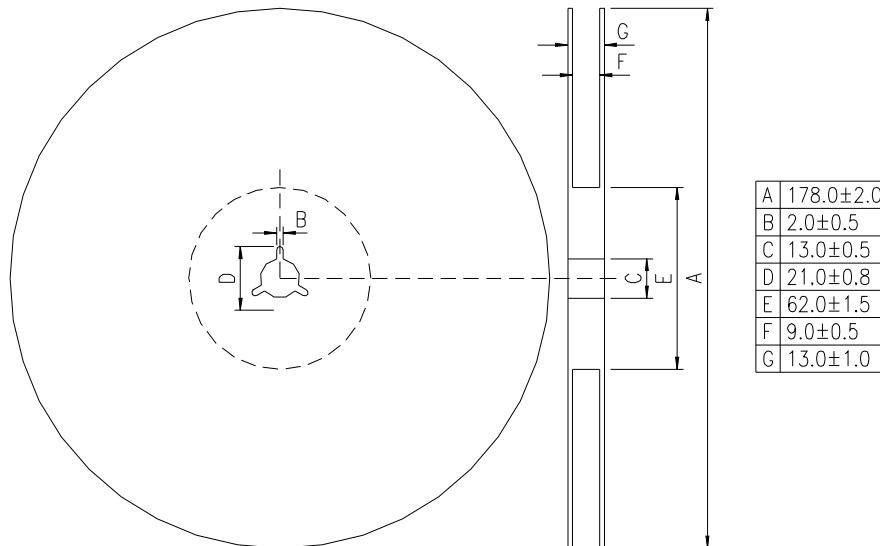

Unit: mm

**5.4. Taping Specifications**

There shall be the portion having no product in both the head and the end of taping, and there shall be the cover tape in the head of taping.

### **5.5. Label Marking**

The label specified as follows shall be put on the side of reel.

(1)Part No.

(2)Quantity

(3)Lot No.

\*Part No. And Quantity shall be marked on outer packaging.

### **5.6. Quantity of Products in the Taping Package**

(1) Standard quantity : 15000pcs/Reel for TVL0201 Series

(2) Shipping quantity is a multiple of standard quantity.

### **5.7. Storage Condition with Package**

Storage Time: 12 months max

Storage Temperature : 5 to 40°C

Relative Humidity: 0 to 60%

## **6. Precautions for Handling**

**6.1. Solder Cream in Reflow Soldering**

Refer to the recommendable land pattern as printing mask pattern for solder cream.

- (1) Print solder in a thickness of 150 to 200μm.
- (2) Dimensions: millimeters

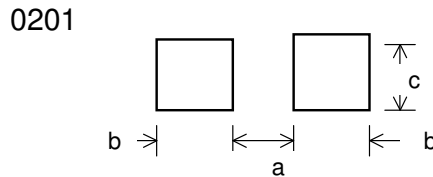

Unit: mm

Type	a	b	c
0201	0.2~0.3	0.25~0.30	0.3~0.4

Notes: This land layout is for reference purposes only. Please consult your manufacturing partners to ensure your company's PCB design guidelines are met.

**6.2. Precaution for Handling of Substrate**

Do not exceed to bend the board after soldering this product extremely.

(Reference examples)

- Mounting place must be as far as possible from the position, which is close to the break line of board, or on the line of large holes of board.
- Do not bend extremely the board, in mounting other components.  
If necessary, use back-up pin (support pin) to prevent from bending extremely.
- Do not break the board by hand. We recommend using the machine or the jig to break it.

**6.3. Precaution for Soldering**

Note that rapid heating, rapid cooling or local heating will easily damage this product. Do not give heat shock over 100°C in the process of soldering. We recommend taking preheating and gradual cooling.

**6.4. Recommendable Reflow Soldering**

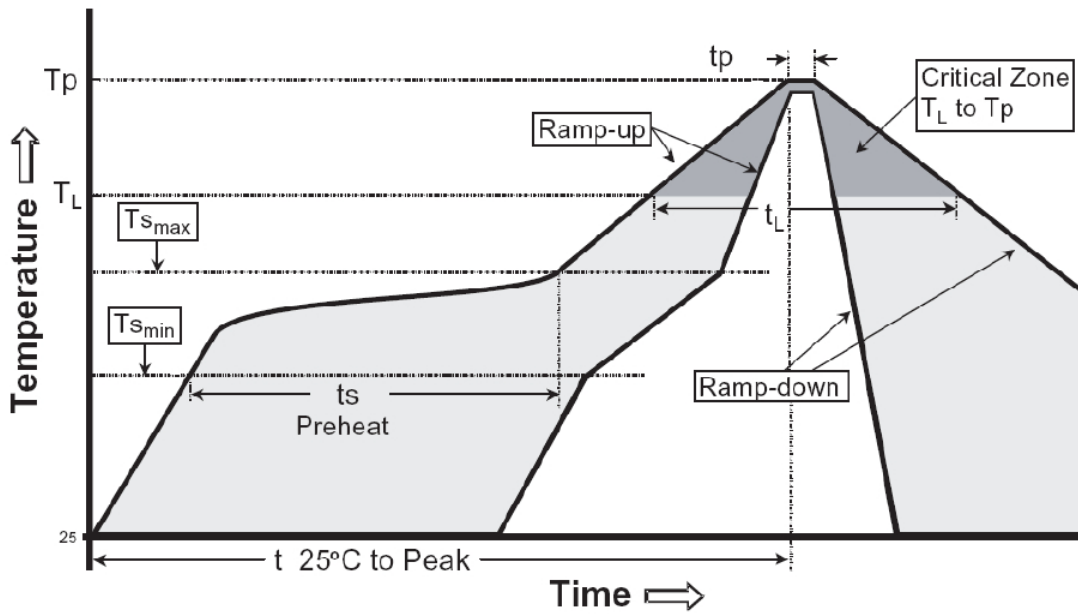

Profile Feature	Pb free Assembly
Average Ramp Rate (Ts max to Tp)	3°C/second max
Preheat	
- Temperature Min (Tsmin)	150°C
- Temperature Min (Tsmax)	200°C
- Time(tsmin to tsmin)	60-180 seconds
Time maintained above:	
- Temperature (TL)	217°C
- Time (tL)	60-150 seconds
Peak Temperature (Tp)	260°C +0/-5 °C
Time within 5°C of actual Peak Temperature (Tp)	Max 20-40 seconds.
Ramp-Down Rate	6°C/second max.
Time 25°C to Peak Temperature	8 minutes max

\*According to J-STD-020C

### 6.5. Soldering Gun Procedure

Note the follows, in case of using solder gun for replacement.

- (1) The tip temperature must be less than 350°C for the period within 6 seconds by using soldering gun less than 30W.
- (2) The soldering gun tip shall not touch this product directly.

#### **6.6. Soldering Volume**

Note that excess of soldering volume will easily get crack the body of this product.

#### **6.7. MSL Level:**

Level 1