

SERIES S0603

Hi-Rel Surface Mount Chip Inductors

INDUCTANCE (nH) ±5%
 DASH NUMBER*
 Q MINIMUM
 INDUCTANCE & Q TEST FREQUENCY (MHz)
 SRF MINIMUM (MHz)
 DC RESISTANCE MAXIMUM (OHMS)
 CURRENT RATING MAXIMUM (mA)

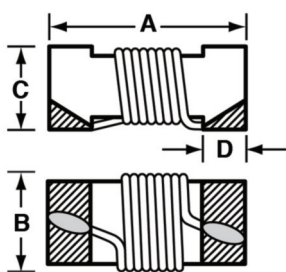

← Actual Size (Max.)

Physical Parameters

	Inches	Millimeters
A	0.058 - 0.062	1.473 - 1.575
B	0.028 - 0.035	0.711 - 0.889
C	0.040 Max.	1.016 Max.
D	0.011 - 0.015	0.279 - 0.381

Operating Temperature Range -55°C to +125°C

Current Rating at 90°C Ambient +35°C Rise

Insulation Resistance at 100 Vdc 1000 Mohm Min.

Dielectric Withstanding Voltage (DWV) 200 Vrms.

Core Material / Termination

Al₂O₃ / Sintered MoMn / Electroplated Ni /
 Electroplated Au Finish (RoHS)
 Termination Options: Au Finish (RoHS)

Electrical Characteristics Measured at +25°C

Outgassing Compliant Per; MIL-STD-883
 Method 5011 and NASA-RP-1124 ASTM E595

SERIES S0603						
-3N3	3.3	18	250	6000	0.100	700
-5N6	5.6	18	250	5800	0.190	700
-8N2	8.2	24	250	4800	0.150	700
-10N	10.0	28	250	4800	0.160	700
-15N	15.0	32	250	4000	0.200	700
-22N	22.0	35	250	3000	0.220	700
-33N	33.0	37	250	2300	0.250	600
-39N	39.0	37	250	2200	0.280	600
-47N	47.0	35	200	2000	0.310	600
-56N	56.0	35	200	1900	0.340	600
-68N	68.0	34	200	1700	0.370	600
-82N	82.0	34	150	1700	0.570	400
-101N	100.0	31	150	1400	0.610	400
-151N	150.0	29	100	1300	0.980	280
-221N	220.0	22	100	1200	1.700	250
-271N	270.0	22	100	900	2.200	200

Inductance Tolerance Options
 M (± 20%), K (± 10%), J (± 5%), H (± 3%), G (± 2%), F (± 1%)

S0603 Test Plan Advantages

- Provides multiple screening alternatives
- Eliminates necessity for SCD's
- Provides quicker delivery
- Reduces overall costs

Manufactured in Cleanroom

- ISO 7 (@0.5 micron)
- Air Cleanliness Classification
- Room Pressurization
- Air Change Rate
- HEPA Filter Leak Testing

How To Order:

S0603 -101N J 1 C Z
 (A) (B) (C)(D)(E) (F)
 (A) Inductor Series (S0603)
 (B) Inductance Value (-3N3 through -271N)
 (C) Inductance Tolerance (M, K, J, H, G, F)
 (D) Termination Finish (1 = Au Finish (RoHS))
 (E) Test Plan Screening (S, C, B, D, E, U, Y)
 (F) Test Report (Blank = Pass/Fail Report)
 (Z = Serialized Test Report)

S0603 Test Plan Options

Ordering Option Code		S	C	B	D	E	U	Y
Screening Level		MIL-STD-981 Class "S"	MIL-STD-981 Class "S" Modified	MIL-STD-981 Class "B"	MIL-STD-981 Class "B" Modified	High Temp	Burn-In	Commercial
Test	Method							
Thermal Shock	MIL-PRF-83446	25 Cycles 1/ (-55°C to +125°C)	25 Cycles (-55°C to +125°C)	25 Cycles 1/ (-55°C to +125°C)	25 Cycles (-55°C to +125°C)	5 Cycles (-55°C to +175°C)		
No-Load Burn-In	MIL-STD-981	125°C (96 hours)	125°C (96 hours)	125°C (96 hours)	125°C (96 hours)	200°C (96 hours)	•	
Dielectric Withstanding Voltage	MIL-PRF-83446	200 Vrms		200 Vrms				
Insulation Resistance	MIL-PRF-83446	1000 Mohms		1000 Mohms				
Electrical Characteristics: L, Q, DCR, SRF	MIL-PRF-83446	•	•	•	•	•	•	•
Radiographic Inspection	MIL-STD-981	•	•	•	•	•	•	•
Visual & Dimensional Examination (external)	MIL-PRF-83446	•	•	•	•	•	•	•
* Electrical Characteristics (initial): L, Q, DCR, SRF	MIL-PRF-83446	•	•	•	•	•	•	•
* Low Temperature Operation	MIL-PRF-83446	•	•	•	•	•	•	•
* Temperature Rise	MIL-PRF-83446	•	•	•	•	•	•	•
* Overload	MIL-PRF-83446	•	•	•	•	•	•	•
* Moisture Resistance	MIL-PRF-83446	•	•	•	•	•	•	•
* Electrical Characteristics: L and Q	MIL-PRF-83446	•	•	•	•	•	•	•
* High Temperature Exposure	MIL-PRF-83446	•	•	•	•	•	•	•
* Electrical Characteristics (final)	MIL-PRF-83446	•	•	•	•	•	•	•
* Bond Strength	MIL-PRF-83446	•	•	•	•	•	•	•
* Visual & Mechanical Examination (external)	MIL-PRF-83446	•	•	•	•	•	•	•
* Visual & Mechanical Examination (internal)	MIL-STD-981	•	•	•	•	•	•	•
* Solderability	MIL-PRF-83446	•	•	•	•	•	•	•
* Electrical Characteristics (initial): L, Q, DCR, SRF	MIL-PRF-83446	•	•	•	•	•	•	•
* Life	MIL-PRF-83446	2000 Hours (90°C Ambient)	500 Hours (90°C Ambient)			500 Hours (175°C Ambient)		
* Dielectric Withstanding Voltage	MIL-PRF-83446	80 Vrms	80 Vrms					
* Insulation Resistance	MIL-PRF-83446	1000 Mohms	1000 Mohms					
* Electrical Characteristics (final): L, Q, DCR, SRF	MIL-PRF-83446	•	•	•	•	•	•	•
* Visual & Mechanical Examination (external)	MIL-PRF-83446	•	•	•	•	•	•	•
* Mechanical Shock/Vibration	MIL-STD-883							

*Destructive Test Units Required

1/ Continually monitor continuity during the entire final cycle to verify no intermittent conditions.

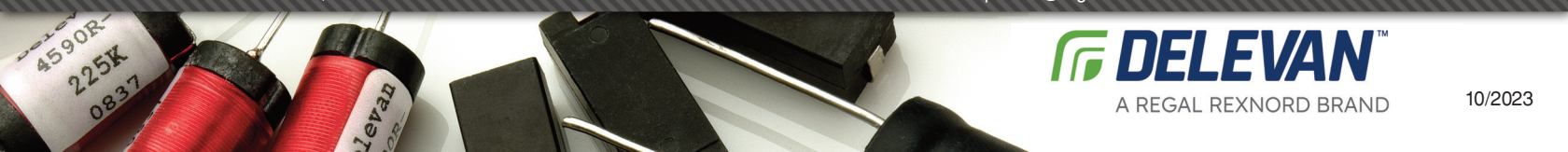

SERIES S0603

Hi-Rel Surface Mount
Chip Inductors

Suggested Land Patterns

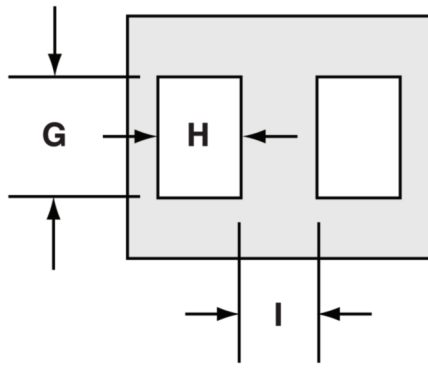

Delevan Series	G		H		I	
	Inches	mm	Inches	mm	Inches	mm
S0603 Series	0.040	1.016	0.025	0.635	0.025	0.635



S-Parameters (Typical)

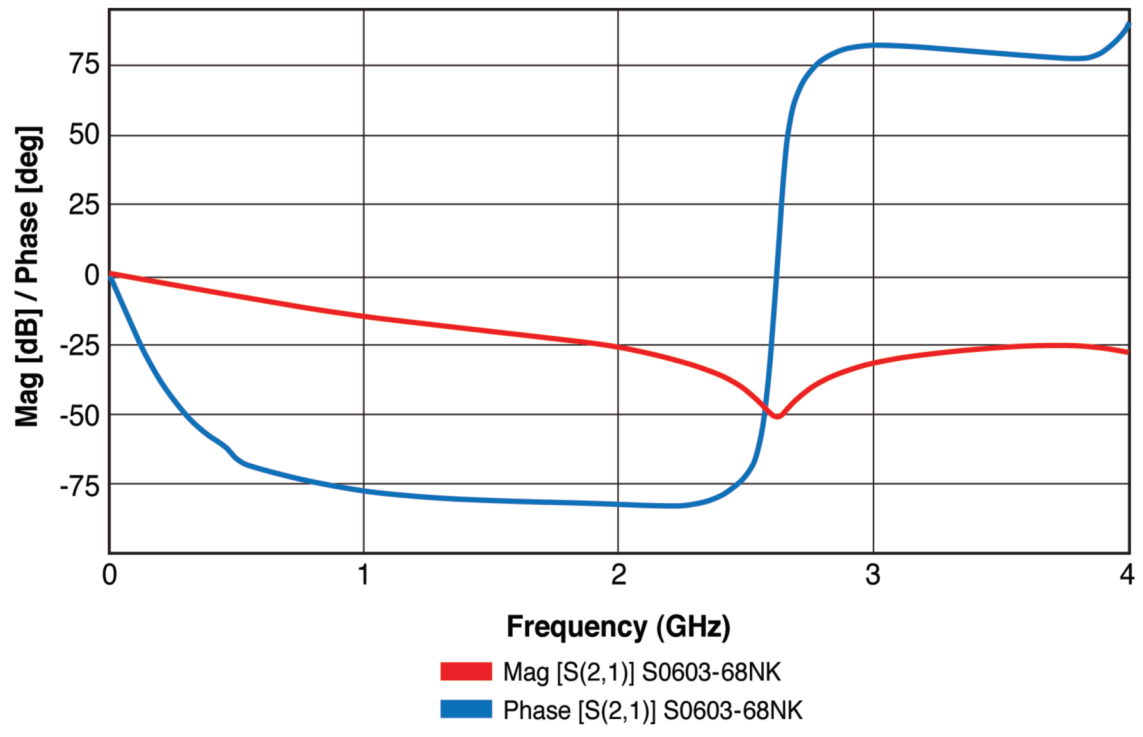

All product specifications and data contained herein are subject to change without notice to improve reliability, function, performance, design or otherwise.

