

Using the LM3631EVM Evaluation Module

User's Guide



Literature Number: SNVU370
AUGUST 2014

1	Overview	4
2	LM3631 Device	4
	2.1 Features.....	4
	2.2 Applications.....	4
	2.3 Power Sequences.....	5
	2.3.1 Start-up.....	5
	2.3.2 Shutdown.....	5
3	Evaluation Module	5
	3.1 Quick Setup.....	5
	3.2 Setting Up.....	6
	3.3 Evaluation Hardware.....	8
	3.4 Evaluation Software.....	9
	3.4.1 General Tab.....	9
	3.4.2 Backlight Tab.....	10
	3.4.3 LCD Bias Tab.....	11
	3.4.4 History Tab.....	13
4	Bill of Materials	16
5	Schematic	17

List of Figures

1	Evaluation Software Setup File	6
2	Software Installation	7
3	Evaluation Hardware	8
4	General Tab of Evaluation Software	10
5	Backlight Tab of Evaluation Software	11
6	LCD Bias Tab of Evaluation Software	12
7	History Tab of Evaluation Software	13
8	LM3631EVM Main Schematic	17
9	LM3631EVM USB Interface Schematic	18

The LM3631EVM Evaluation Module

This user's guide describes the characteristics, operation, and use of the LM3631 Complete LCD Backlight and Bias Power device evaluation module (EVM). This document includes descriptions of the device, as well as the evaluation hardware and software. It also includes a schematic of the EVM.

For related documents please check the [LM3631 datasheet](#).

If you need assistance regarding this device or the EVM, please contact your local TI sales representative.

1 Overview

Texas Instruments' LM3631EVM helps designers evaluate the operation and performance of the LM3631 device. The LM3631EVM uses the LM3631 to create backlight power and LCD bias powers. Information about device characteristics and current ratings of LM3631 can be found in the datasheet. In order to facilitate ease of testing and evaluation of this circuit, the EVM contains a TI MSP430 microprocessor to provide easy communication via USB. The EVM also contains an external power supply connection for the VIN and VIO. Additionally, test points for signals can be found on the EVM. For evaluation purposes, the EVM has been tested over a 2.7V to 5.0V input range. This voltage range is within the absolute maximum input range of the LM3631. Users are cautioned to evaluate their specific operating conditions and choose components with the appropriate voltage ratings before designing this support circuitry into a final product.

2 LM3631 Device

The LM3631 provides a high-efficiency backlight and positive/negative bias supplies for LCD drivers to address the power requirements of high-definition LCDs. Capable of driving up to 16 LEDs, the LM3631 is ideal for small format displays. A high level of integration and programmability allows the LM3631 to address a variety of applications without the need for hardware changes.

2.1 Features

- Drives up to 2 Strings of Maximum of 8 LEDs in Series with up to 25 mA per String
- Backlight Up to 90% Efficient
- LCD Bias Efficiency >85%
- 11-Bit Exponential or Linear Dimming
- External PWM Brightness Control for CABC Backlight Operation
- Positive Programmable LCD bias, 100 mA
- Negative Programmable LCD bias, up to 80 mA
- Two Positive Programmable LDO Reference Outputs, 50 mA and 80 mA
- 2.7-V to 5-V Input Voltage Range

2.2 Applications

Mobile Device LCD Backlighting and Bias

2.3 Power Sequences

2.3.1 Start-up

After the nRST pin is set high and VBAT rises over the undervoltage lock-out (UVLO) limit, the LM3631 goes to Standby mode. Before entering Standby mode, references and bias currents are enabled (bias delay typically 200 μ s), and registers are read from OTP (EPROM read delay typically 700 μ s). In Standby mode references and bias currents are enabled, and I²C writes are allowed. Oscillator, LCD powers, and backlight are disabled. During an I²C write, the oscillator is enabled.

When LCD_EN is set to high (pin or bit), the start-up sequence is started. During the start-up sequence LDO_CONT, LCD Boost, and LCD bias powers are started. If the LDO_CONT is disabled, the start-up sequence goes directly to LCD Boost start-up.

LDO_CONT start-up: LDO_CONT is enabled. Programmable delay of 0 - 200 ms.

LCD Boost start-up: LCD Boost is enabled. Waits until Boost output voltage is reached 90% of target value.

LCD bias start-up: Enables sequentially LDO_VPOS, CP_VNEG, and LDO_OREF according to start-up delay settings. After the LCD bias start-up, the LM3631 enters backlight start-up mode if the BL_EN bit is set to '1' and the PWM brightness value is different than 0. Even though backlight is not enabled, LCD remains active. If backlight is enabled and the BL_EN bit or PWM brightness value is set to '0', backlight is disabled; LCD remains active.

2.3.2 Shutdown

If LCD_EN is set to '0', the device enters shutdown. In shutdown the backlight is shut down first (if it is enabled) . After backlight shutdown is completed, the device enters LCD Bias shutdown. In LCD bias shutdown LDO_VPOS, CP_VNEG, and LDO_OREF are shut down sequentially according to shutdown delay settings. After the LDO_VPOS, CP_VNEG, and LDO_OREF shutdown sequence is complete, the LCD Boost and LDO_CONT (if they are enabled) are shut down. LDO_CONT is shut down after adjustable delay (0 – 200 ms). Then the device enters Standby mode. If there is a fault situation (UVLO, Thermal, backlight boost short circuit, backlight overcurrent, LDO_OREF overcurrent, VPOS overcurrent, and CP short circuit), the device starts the shutdown sequence.

3 Evaluation Module

The LM3631 evaluation module consists of an evaluation board (hardware) and evaluation software.

3.1 Quick Setup

This section shortly describes how to connect and setup LM3631 EVM.

(A) Connect external power supply to VIN and GND of EVM. Set the voltage to, for example, 3.6 V.

(B) Connect USB cable to EVM.

(C) Start the Evaluation program from white arrow on left hand top corner.

(D) Check the nRST and LCD_EN boxes in General tab. Program reads the registers automatically.

(E) By now the LM3631 should be giving out VPOS and CP_VNEG voltages. Also LCD boost is on. Backlight is off.

(F) Setting backlight on:

- Switch to Backlight tab.
- Select "I2C Register" -control from Brightness Mode -pulldown menu.
- Set the brightness value from Brightness-slider.
- Push the Update Brightness -button

3.2 Setting Up

The LM3631EVM is connected via USB to the computer. The EVM is controlled with special evaluation software. An MSP430 microcontroller is used in the EVM to provide easy I²C communication, nRST-pin, LCD_EN-pin, OTP_SEL-pin, and PWM control with the LM3631 via USB. The EVM is powered by default via USB. LM3631 device is powered from external power supply. The external power supply need to be connected to the green connector near USB connector.

LM3631 evaluation software (available at www.ti.com) uses the LabVIEW runtime engine which needs to be installed (if not installed previously). The LM3631 Evaluation Software Installer includes the setup.exe which installs the LM3631 evaluation software and LabVIEW runtime engine to Windows computer.

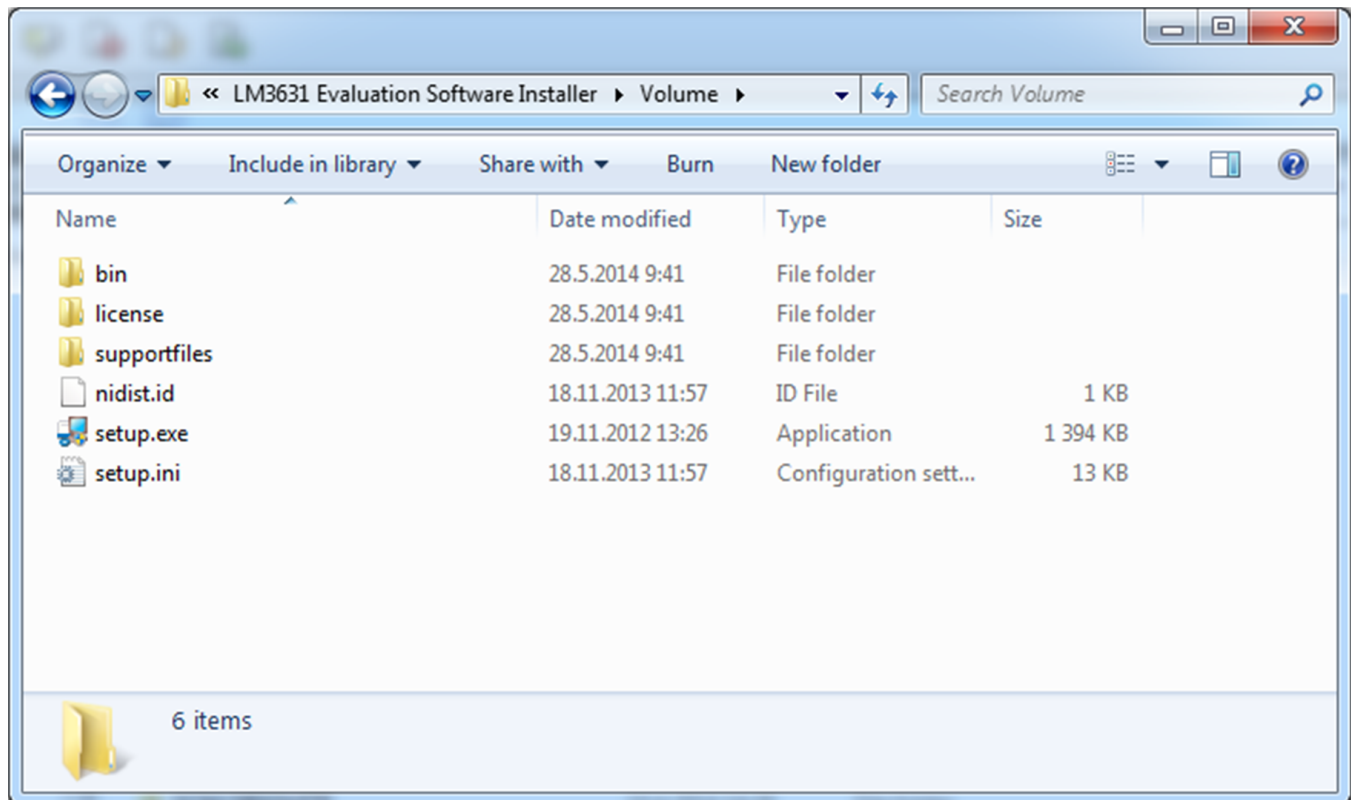

Figure 1. Evaluation Software Setup File

Running the setup opens up the installer, which prompts the Destination Directory where the program is to be installed. Note that user needs to have administrator rights to be able to install this program.

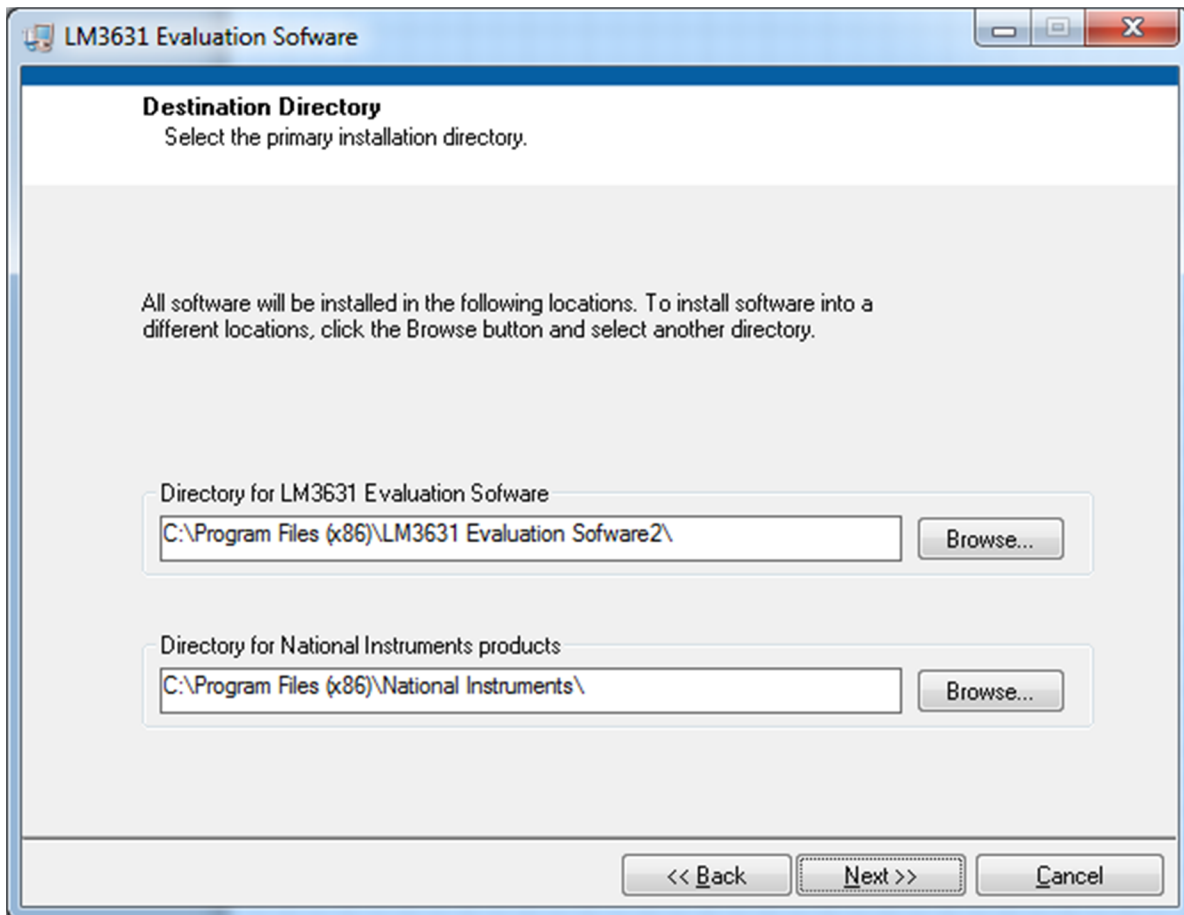

Figure 2. Software Installation

When the board is connected to a computer, Windows should recognize it automatically and start to install the driver. A “Found New Hardware” dialog box will prompt user to locate the missing driver. Select “No, not this time” and continue with “Next”. Select “Install from a list or specific location (Advanced)” to install the driver. Select the directory where the TI_CDC_Virtual_Port driver is. Windows should now install the driver, and the PC can communicate with the EVM using a virtual COM port. If Windows cannot find the driver, user needs to manually install the TI_CDC_Virtual_Port driver from the Device Manager.

Once the board is connected and the driver is installed, the red LED should blink on the evaluation board, indicating the board is recognized. The evaluation software scans the USB ports automatically. If the board is not found, the software should prompt regarding this issue. The USB address can be changed manually from the evaluation software; switching to another USB port also might solve the issue.

3.3 Evaluation Hardware

The LM3631 EVM consists basically of two sections:

- LM3631 and the application components; and
- MSP430 microcontroller and the support components.

By default the LM3631 is controlled by the MSP430 microcontroller via USB. VDD voltage come from USB, and the I²C traffic is controlled with the microcontroller. The evaluation hardware also allows external control: the VDD can be fed externally via connector and with jumper selection. The I²C traffic, nRST-pin, LCD_EN-pin, OTP_SEL-pin, PWM and FLAG-pin control can be changed from MSP430 control to external control using a pin header. The LED driver control can be changed from 4 to 8 WLEDs and from 1 to 2 strings. The pin header enables current measurement to the LED drivers. A test point (header) exists for some of the device pins.

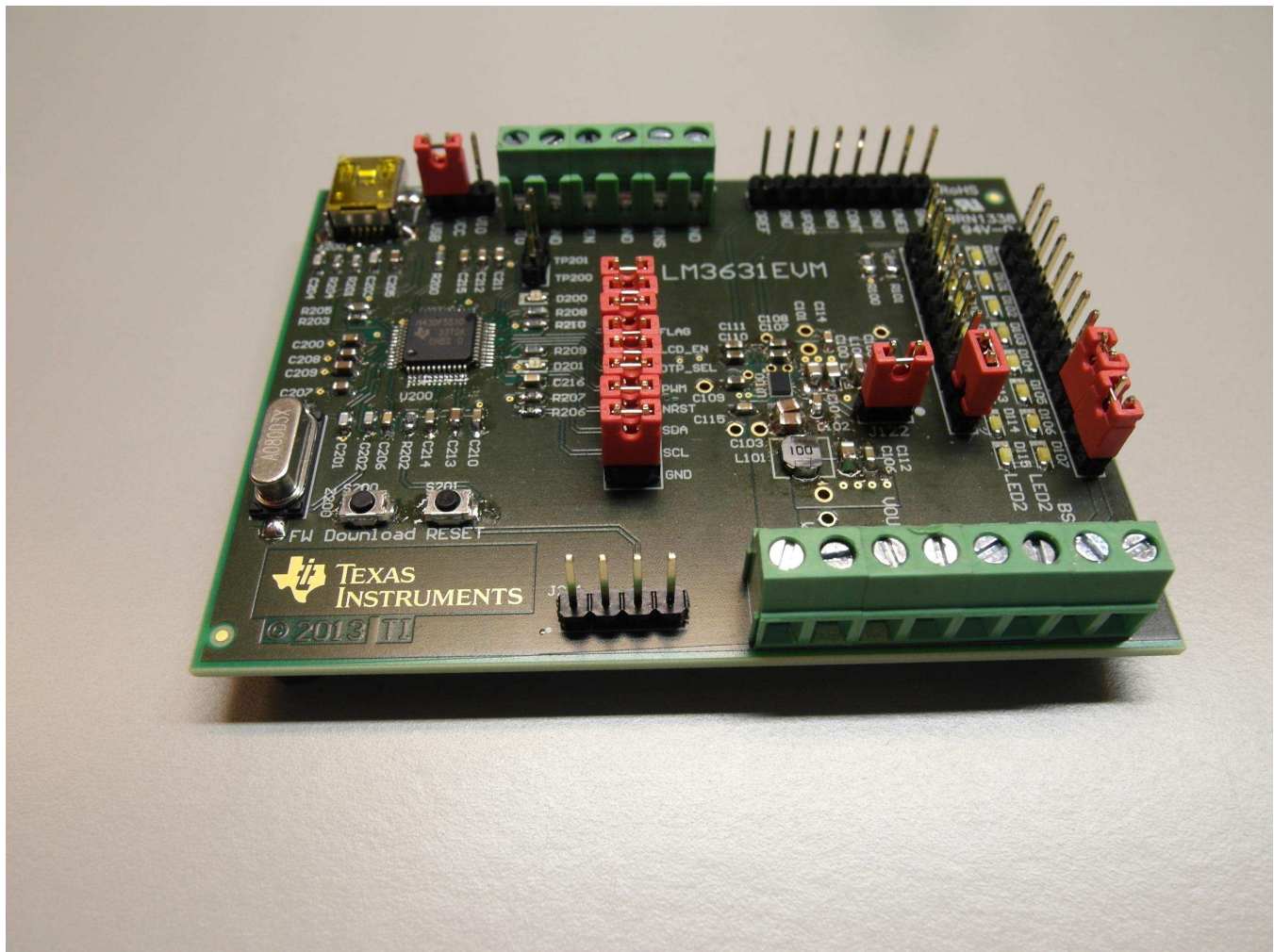

Figure 3. Evaluation Hardware

3.4 Evaluation Software

The LM3631 evaluation software helps user control the evaluation hardware connected to the computer. The evaluation software consists of four tabs: General tab, Backlight tab, LCD Bias tab, and History tab. When opened up, the program goes directly to RUN mode, so the EVM should be connected before opening the software. The program is stopped by pushing the STOP button or the red button on the upper left-hand corner. If stopped, and then user wants to run program again, simply push the white arrow on the upper left-hand corner.

A Help window, for showing control description, can be opened by pushing CTRL+H or from Help menu and selecting Show Context Help.

3.4.1 General Tab

From the General tab, user can control the following:

- **USB Address:** Evaluation software automatically polls the USB address and, if not found, prompts for error. The USB address is format ASRLx::INSTR, where x is the number of the USB port. The USB address can be changed by clicking the Address field, writing a new address value, and pushing the Init Communication button.
- **Device I2C Address:** This is the I²C address of the LM3631 device. The address can be changed by clicking the field, writing a new value, and pushing the Change I2C address button.
- **nRST checkbox:** Setting nRST checkbox active will enable the MSP430 to set the nRST pin HIGH. Unchecking will set the nRST pin LOW.
- **LCD_EN checkbox:** Setting LCD_EN checkbox active will enable the MSP430 to set the LCD_EN pin HIGH. Unchecking will set the LCD_EN pin LOW.
- **OTP_SEL checkbox:** Setting OTP_SEL checkbox active will enable the MSP430 to set the OTP_SEL pin HIGH. Unchecking will set the OTP_SEL pin LOW.
- **PWM frequency and PWM duty cycle:** With the PWM frequency and duty cycle controls, the MSP430-generated PWM can be controlled. Frequency and duty cycle can be changed with the sliders or with the numerical control below sliders. Values are updated by pushing the Update PWM Frequency and Duty Cycle button.
- The Reset All Registers button performs a register reset for the LM3631.
- The Read All Registers button performs a read for all the registers.
- Device Revision can be read by pushing the Read button next to Device Revision indicator.
- OTP Revision can be read by pushing the Read button next to OTP Revision indicator.
- **Single register read:** User can read a single register by selecting the register from the Register pulldown menu and pushing the Read Register button. The register value will be updated to the Register Value indicator.
- **Faults:** Device faults can be checked by pushing the Check Faults button. Each fault has its own indicator. Faults can be cleared by pushing the Clear Faults button or by an individual Clear button. The Clear Faults button clears all the faults.
- **PG FLAG:** FLAG-pin status can be read by pushing the Read button under the PG_FLAG indicator. PG Flag polarity can be controlled with a switch and from two pulldown menus.

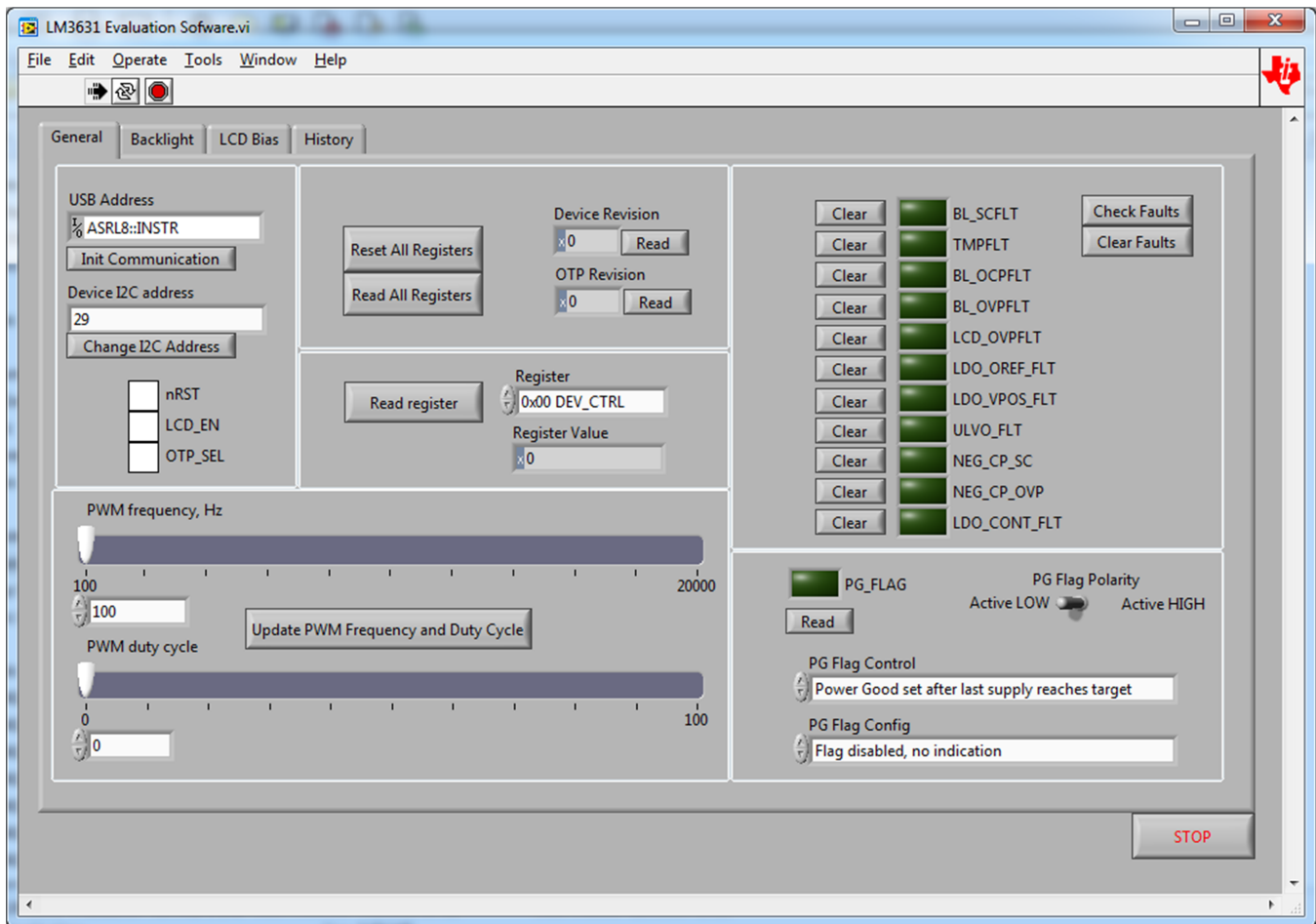

Figure 4. General Tab of Evaluation Software

3.4.2 Backlight Tab

From the Backlight tab user can control the bits related to backlight:

- Enable Backlight checkbox: by checking this, the BL_EN bit is set HIGH; unchecking will set the bit LOW.
- Enable Advanced Slope checkbox: by checking this, the EN_ADV_SLOPE bit is set HIGH; unchecking will set the bit LOW.
- Disable Dither checkbox: by checking this, the DISABLE_DITHER bit is set HIGH; unchecking will set the bit LOW.
- Mapper: With Mapper switch user can select the mapping mode.
- String Mode: With String Mode switch user can select LED string mode.
- Brightness Mode: With the Brightness Mode pulldown menu the brightness mode can be selected.
- Slope: With the Slope pulldown menu the brightness slope time can be selected.
- Dither Frequency: With the Dither Frequency pulldown menu the dithering frequency can be selected.
- Brightness: With Brightness control the 11-bit brightness is controlled. Brightness can be controlled with the slider or control below the slider. Brightness value is updated by pushing the Update brightness button.
- Auto Freq Threshold: With Auto Freq Threshold button the 8-bit auto frequency threshold can be controlled. Its value can be controlled with the slider or control below the slider. Value is updated by pushing the Update threshold button.

- Auto Freq mode can be selected with the Auto Freq switch.
- Backlight boost peak-current limit can be selected from Peak Current Limit pulldown menu control.
- Backlight boost over-voltage protection limit can be selected from BL Boost OVP pulldown menu control.
- Backlight boost Min Inductor switch controls the MIN_INDUCTOR bit.
- Backlight boost BL Boost Freq switch selects the backlight boost frequency.
- SEL_I term can be controlled with pulldown menu control.
- SEL_P term can be controlled with pulldown menu control.
- PWM input signal edge detection can be selected with Edge Detection switch.
- PWM input signal polarity selection can be done with PWM Polarity switch.
- PWM input hysteresis can be selected with PWM Hysteresis pulldown menu control.

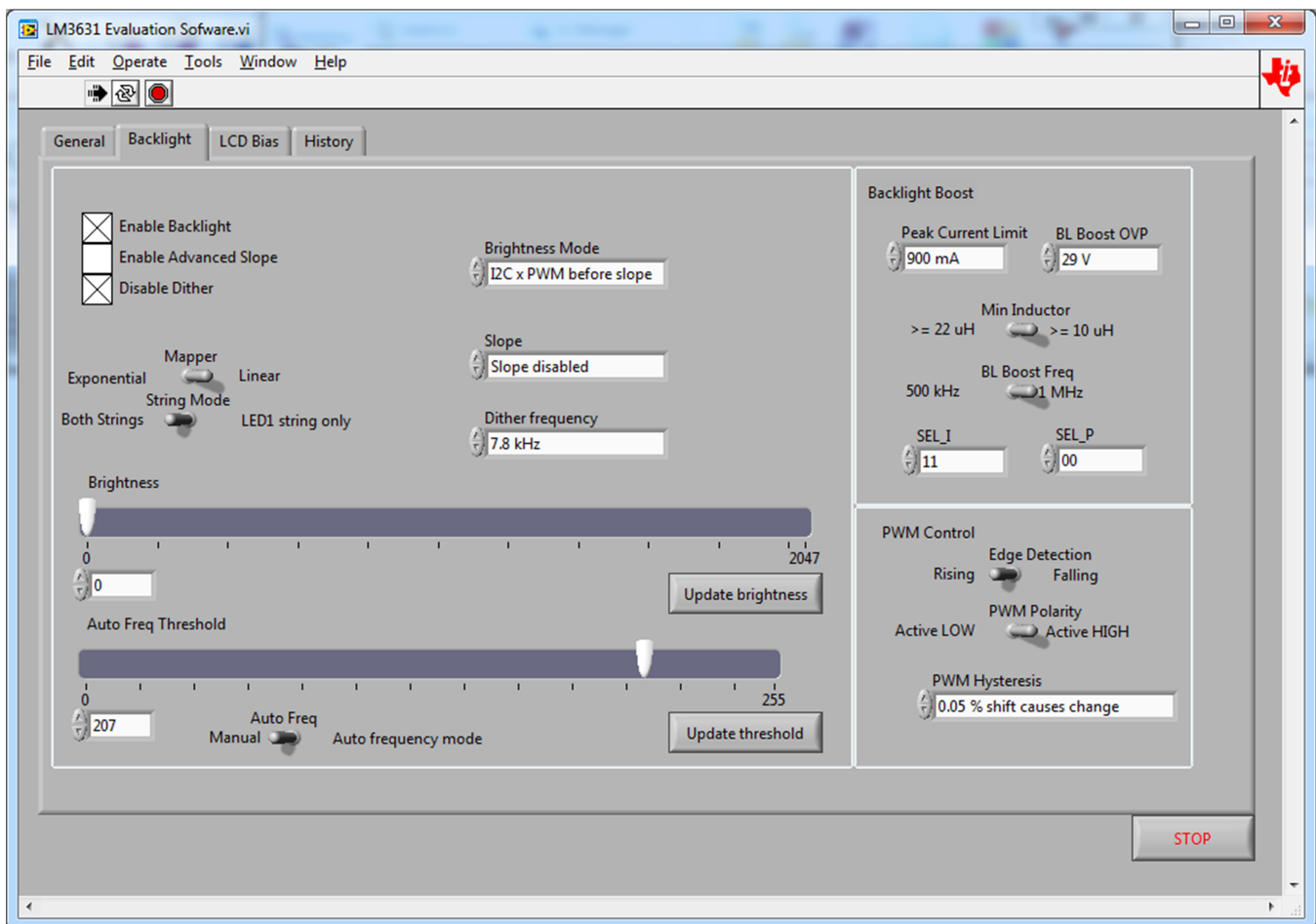

Figure 5. Backlight Tab of Evaluation Software

3.4.3 LCD Bias Tab

The LCD Bias tab contains the controls for bias powering:

- Enable LCD checkbox: by checking this the LCD_EN bit is set HIGH; unchecking sets the bit LOW.
- Enable LDO_VPOS checkbox: by checking this the LDO_VPOS_EN bit is set HIGH; unchecking sets the bit LOW.
- Enable CP_VNEG checkbox: by checking this the CP_VNEG_EN bit is set HIGH; unchecking sets the bit LOW.

- Enable LDO_OREF checkbox: by checking this the LDO_OREF_EN bit is set HIGH; unchecking sets the bit LOW.
- Enable LDO_CONT checkbox: by checking this the LDO_CONT_EN bit is set HIGH; unchecking sets the bit LOW.
- Enable LDO_CONT pulldown checkbox: by checking this the LDO_CONT_SD_PULLDN bit is set HIGH; unchecking sets the bit LOW.
- Enable LDO_OREF pulldown checkbox: by checking this the LDO_OREF_SD_PULLDN bit is set HIGH; unchecking sets the bit LOW.
- Enable CP_VNEG pullup checkbox: by checking this the CP_VNEG_SD_PULLUP bit is set HIGH; unchecking sets the bit LOW.
- Enable LDO_VPOS pulldown checkbox: by checking this the LDO_VPOS_SD_PULLDN bit is set HIGH; unchecking sets the bit LOW.
- LCD Boost output voltage is selected with the LCD Boost output voltage pulldown menu control.
- LDO_CONT start-up delay, shutdown delay, and output voltage are controlled with the LDO_CONT pulldown menu controls.
- LDO_VPOS start-up delay, shutdown delay, and output voltage are controlled with the LDO_VPOS pulldown menu controls.
- CP_VNEG start-up delay, shutdown delay, and output voltage are controlled with the CP_VNEG pullup menu controls.
- LDO_OREF start-up delay, shutdown delay, and output voltage are controlled with the LDO_OREF pulldown menu controls.

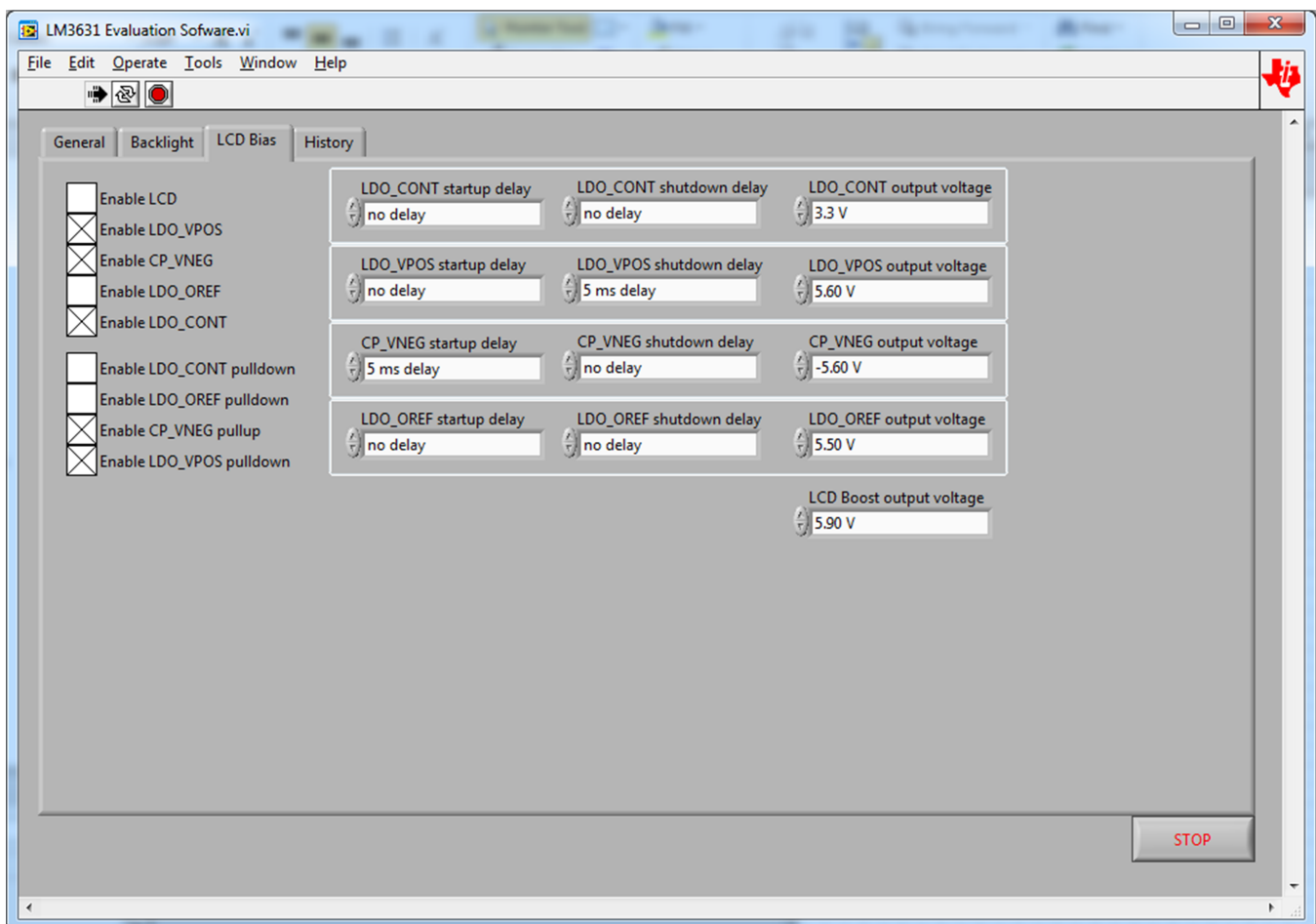

Figure 6. LCD Bias Tab of Evaluation Software

3.4.4 History Tab

From the History tab user can check all the instructions and I²C commands given to the LM3631 device. In this tab user can also create scripts for controlling the LM3631 device. Scripts are entered into Script control. Once script is ready its commands are run by pushing the Run Script button. User can also save, load, and clear scripts with the associated buttons.

The list below shows the available commands for the I²C register bits. After the '=' comes the wanted value. An underscore is needed, but text can be either lower case, upper case, or a mix. There can be spaces — they are ignored.

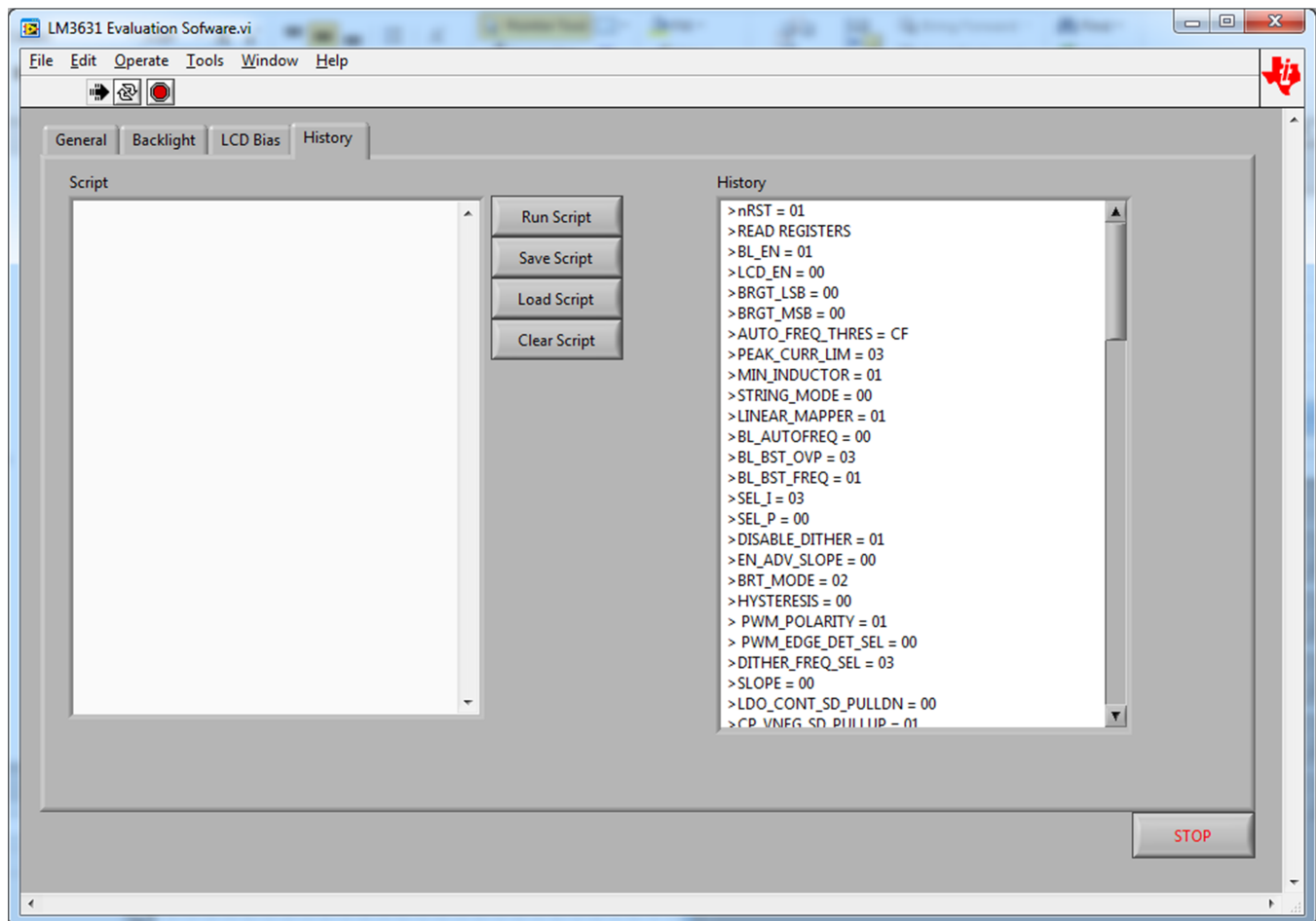

Figure 7. History Tab of Evaluation Software

- BL_EN=
- LCD_EN=
- BRGT_LSB=
- BRGT_MSB=
- AUTO_FREQ_THRES=
- PEAK_CURR_LIM=
- MIN_INDUCTOR=
- STRING_MODE=
- LINEAR_MAPPER=
- BL_BST_FREQ=
- BL_BST_OVP=

- BL_AUTOFREQ=
- SEL_P=
- SEL_I=
- DISABLE_DITHER=
- EN_ADV_SLOPE=
- BRT_MODE=
- HYSTERESIS=
- PWM_POLARITY=
- PWM_EDGE_DET_SEL=
- DITHER_FREQ_SEL=
- SLOPE=
- LDO_OREF_EN=
- CP_VNEG_EN=
- LDO_VPOS_EN=
- LDO_VPOS_SD_PULLDN=
- CP_VNEG_SD_PULLUP=
- LDO_OREF_SD_PULLDN=
- LDO_CONT_SD_PULLDN=
- LDO_CONT_EN=
- LDO_CONT_SD_DELAY=
- LDO_CONT_SU_DELAY=
- LCD_BST_VOUT=
- LDO_CONT_VOUT=
- LDO_VPOS_VOUT=
- LDO_VPOS_TARGET=
- CP_VNEG_VOUT=
- CP_VNEG_TARGET=
- LDO_OREF_VOUT=
- LDO_OREF_TARGET=
- LDO_VPOS_SD_DELAY=
- LDO_VPOS_SU_DELAY=
- CP_VNEG_SD_DELAY=
- CP_VNEG_SU_DELAY=
- LDO_OREF_SD_DELAY=
- LDO_OREF_SU_DELAY=
- PG_FLAG_CONFIG=
- PG_FLAG_CTRL=
- PG_FLAG_POLARITY=
- FLAG_PIN_POLARITY=

The following list shows other commands that are for reading, clearing, and booting (RESET, RST and BOOT). The PIN controls are also specified below.

- RESET "resets the device, register reset"
- RST "resets the device, register reset"
- BOOT "resets the device, register reset"
- DEV_REV "reads the device revision"
- OTP_REV "reads the OTP revision"
- CLEARFAULTS "clears all faults"
- READFAULTS "reads the faults"
- READFLAG "reads flag status"
- READPG "reads flag status"
- CLEARBL_SCFLT "clears fault"
- CLEARTMPFLT "clears fault"
- CLEARBL_OCPFLT "clears fault"
- CLEARBL_OVPFLT "clears fault"
- CLEARLCD_OVPFLT "clears fault"
- CLEARLDO_OREF_FLT "clears fault"
- CLEARLDO_VPOS_FLT "clears fault"
- CLEARUVLO_FLT "clears fault"
- CLEARNEG_CP_SC "clears fault"
- CLEARNEG_CP_OVP "clears fault"
- CLEARLDO_CONT_FLT "clears fault"
- NRST= "set nRST pin"
- LCD_EN_PIN= "set LCD_EN pin"
- OTP_SEL= "set OTP_SEL pin"
- FLAG_PIN_CONFIG= "flag pin configuration"
- FLAG_PIN_CONTROL= "flag pin control"
- FLAG_PIN_CTRL= "flag pin control"
- WAIT= "wait command"
- READREG "read register"
- READREGISTER "read register"
- RREG "read register"
- RREGISTER "read register"

4 Bill of Materials

Table 1 shows a bill of materials for LM3631 key components.

Table 1. LM3631 BOM

Designator	Qty	Description	Value	Part Number
U100	1	Complete LCD Backlight and Bias Power		LM3631
C100, C101, C105, C106	4	Ceramic Capacitor	10 μ F, 16 V	GRM21BR61C106KE15L
C102, C103	2	Ceramic Capacitor	2.2 μ F, 50 V	C2012X5R1H225K125AB
C104, C112, C113	3	Ceramic Capacitor	0.1 μ F, 25 V	C1608X7R1E104K080AA
C107, C108, C109, C110, C111	5	Ceramic Capacitor	10 μ F, 16 V	EMK107BBJ106MA-T
C114, C115	2	Ceramic Capacitor	100 pF, 50 V	06035A101JAT2A
D100, D101, C102, D103, D104, D105, D106, D107, D108, D109, D110, D111, D112, D113, D114, D115	16	White LED		SML312WBCW1
D116	1	Schottky Diode	40 V, 0.2 A	NSR0240P2T5G
L100	1	Inductor, Multilayer	1.5 μ H, 1.2 A	MLP2016H1R5MT0S1
L101	1	Inductor, Wirewound	10 μ H	NRS4012T100MDGJV
R100, R101	2	Resistor	10 Ω	CRCW080510R0FKEA

5 Schematic

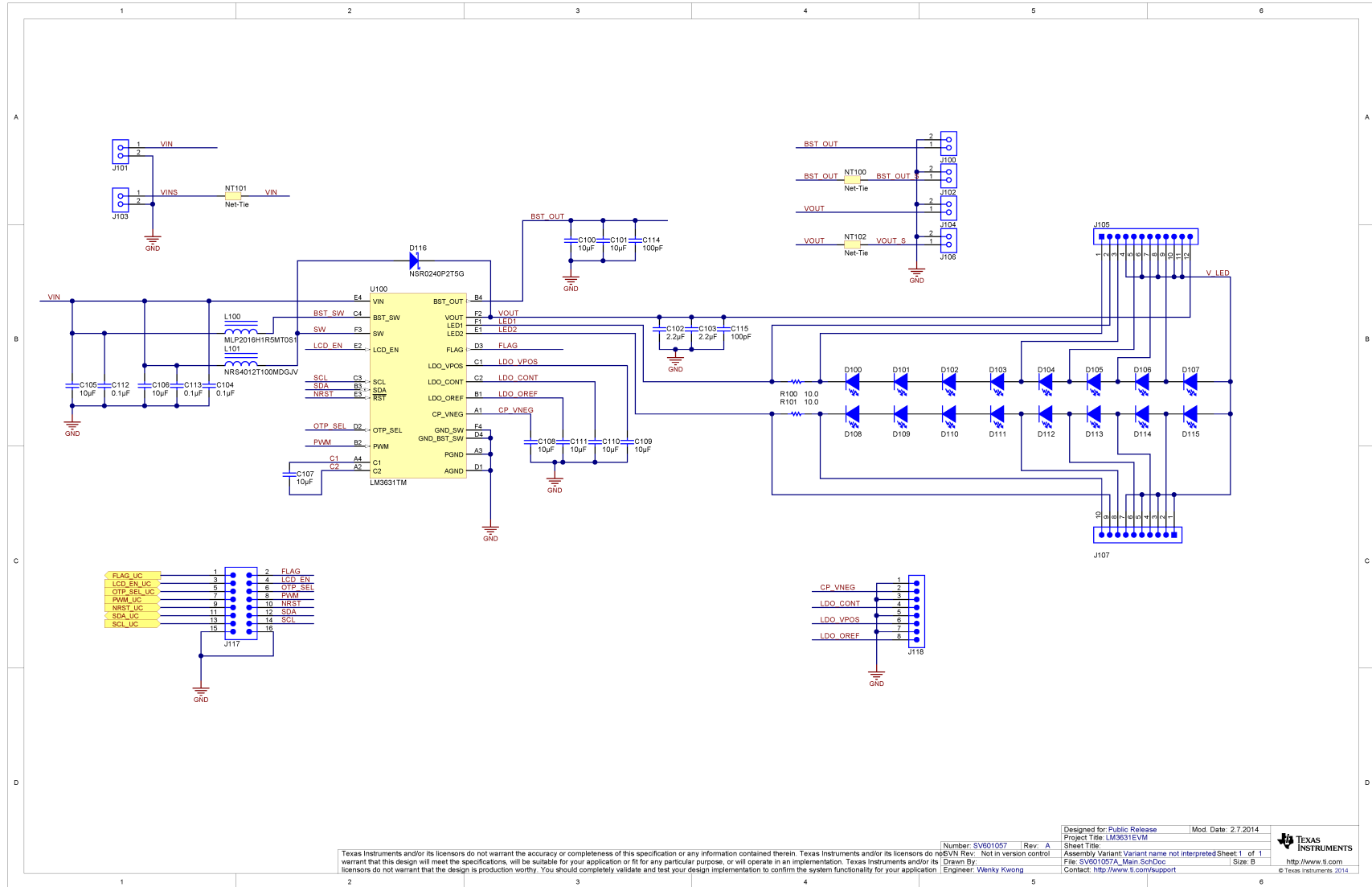

Designed for Public Release | Mod. Date: 2.7.2014
 Project Title: LM3631EVM
 Number: SV601057 | Rev: A
 Sheet Title: Assembly Variant name not interpreted
 File: SV601057A_Main_SchDoc | Drawn By: | Size: B
 Contact: http://www.ti.com/support
 © Texas Instruments 2014

Figure 8. LM3631EVM Main Schematic

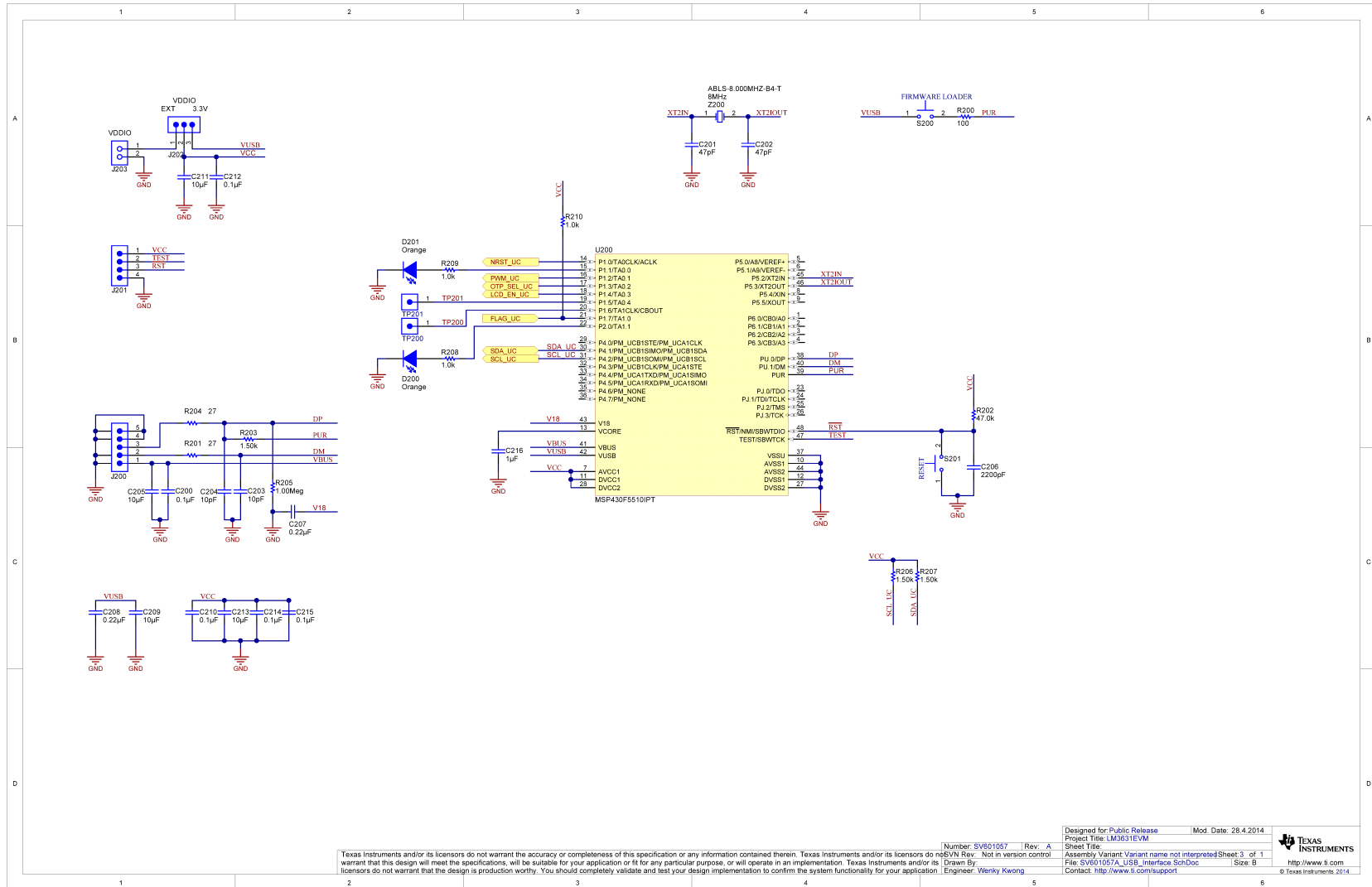

Figure 9. LM3631EVM USB Interface Schematic

IMPORTANT NOTICE

Texas Instruments Incorporated and its subsidiaries (TI) reserve the right to make corrections, enhancements, improvements and other changes to its semiconductor products and services per JESD46, latest issue, and to discontinue any product or service per JESD48, latest issue. Buyers should obtain the latest relevant information before placing orders and should verify that such information is current and complete. All semiconductor products (also referred to herein as "components") are sold subject to TI's terms and conditions of sale supplied at the time of order acknowledgment.

TI warrants performance of its components to the specifications applicable at the time of sale, in accordance with the warranty in TI's terms and conditions of sale of semiconductor products. Testing and other quality control techniques are used to the extent TI deems necessary to support this warranty. Except where mandated by applicable law, testing of all parameters of each component is not necessarily performed.

TI assumes no liability for applications assistance or the design of Buyers' products. Buyers are responsible for their products and applications using TI components. To minimize the risks associated with Buyers' products and applications, Buyers should provide adequate design and operating safeguards.

TI does not warrant or represent that any license, either express or implied, is granted under any patent right, copyright, mask work right, or other intellectual property right relating to any combination, machine, or process in which TI components or services are used. Information published by TI regarding third-party products or services does not constitute a license to use such products or services or a warranty or endorsement thereof. Use of such information may require a license from a third party under the patents or other intellectual property of the third party, or a license from TI under the patents or other intellectual property of TI.

Reproduction of significant portions of TI information in TI data books or data sheets is permissible only if reproduction is without alteration and is accompanied by all associated warranties, conditions, limitations, and notices. TI is not responsible or liable for such altered documentation. Information of third parties may be subject to additional restrictions.

Resale of TI components or services with statements different from or beyond the parameters stated by TI for that component or service voids all express and any implied warranties for the associated TI component or service and is an unfair and deceptive business practice. TI is not responsible or liable for any such statements.

Buyer acknowledges and agrees that it is solely responsible for compliance with all legal, regulatory and safety-related requirements concerning its products, and any use of TI components in its applications, notwithstanding any applications-related information or support that may be provided by TI. Buyer represents and agrees that it has all the necessary expertise to create and implement safeguards which anticipate dangerous consequences of failures, monitor failures and their consequences, lessen the likelihood of failures that might cause harm and take appropriate remedial actions. Buyer will fully indemnify TI and its representatives against any damages arising out of the use of any TI components in safety-critical applications.

In some cases, TI components may be promoted specifically to facilitate safety-related applications. With such components, TI's goal is to help enable customers to design and create their own end-product solutions that meet applicable functional safety standards and requirements. Nonetheless, such components are subject to these terms.

No TI components are authorized for use in FDA Class III (or similar life-critical medical equipment) unless authorized officers of the parties have executed a special agreement specifically governing such use.

Only those TI components which TI has specifically designated as military grade or "enhanced plastic" are designed and intended for use in military/aerospace applications or environments. Buyer acknowledges and agrees that any military or aerospace use of TI components which have **not** been so designated is solely at the Buyer's risk, and that Buyer is solely responsible for compliance with all legal and regulatory requirements in connection with such use.

TI has specifically designated certain components as meeting ISO/TS16949 requirements, mainly for automotive use. In any case of use of non-designated products, TI will not be responsible for any failure to meet ISO/TS16949.

Products

Audio	www.ti.com/audio
Amplifiers	amplifier.ti.com
Data Converters	dataconverter.ti.com
DLP® Products	www.dlp.com
DSP	dsp.ti.com
Clocks and Timers	www.ti.com/clocks
Interface	interface.ti.com
Logic	logic.ti.com
Power Mgmt	power.ti.com
Microcontrollers	microcontroller.ti.com
RFID	www.ti-rfid.com
OMAP Applications Processors	www.ti.com/omap
Wireless Connectivity	www.ti.com/wirelessconnectivity

Applications

Automotive and Transportation	www.ti.com/automotive
Communications and Telecom	www.ti.com/communications
Computers and Peripherals	www.ti.com/computers
Consumer Electronics	www.ti.com/consumer-apps
Energy and Lighting	www.ti.com/energy
Industrial	www.ti.com/industrial
Medical	www.ti.com/medical
Security	www.ti.com/security
Space, Avionics and Defense	www.ti.com/space-avionics-defense
Video and Imaging	www.ti.com/video

TI E2E Community

e2e.ti.com

Mailing Address: Texas Instruments, Post Office Box 655303, Dallas, Texas 75265
Copyright © 2014, Texas Instruments Incorporated

STANDARD TERMS AND CONDITIONS FOR EVALUATION MODULES

1. *Delivery:* TI delivers TI evaluation boards, kits, or modules, including any accompanying demonstration software, components, or documentation (collectively, an "EVM" or "EVMs") to the User ("User") in accordance with the terms and conditions set forth herein. Acceptance of the EVM is expressly subject to the following terms and conditions.
 - 1.1 EVMs are intended solely for product or software developers for use in a research and development setting to facilitate feasibility evaluation, experimentation, or scientific analysis of TI semiconductors products. EVMs have no direct function and are not finished products. EVMs shall not be directly or indirectly assembled as a part or subassembly in any finished product. For clarification, any software or software tools provided with the EVM ("Software") shall not be subject to the terms and conditions set forth herein but rather shall be subject to the applicable terms and conditions that accompany such Software
 - 1.2 EVMs are not intended for consumer or household use. EVMs may not be sold, sublicensed, leased, rented, loaned, assigned, or otherwise distributed for commercial purposes by Users, in whole or in part, or used in any finished product or production system.
2. *Limited Warranty and Related Remedies/Disclaimers:*
 - 2.1 These terms and conditions do not apply to Software. The warranty, if any, for Software is covered in the applicable Software License Agreement.
 - 2.2 TI warrants that the TI EVM will conform to TI's published specifications for ninety (90) days after the date TI delivers such EVM to User. Notwithstanding the foregoing, TI shall not be liable for any defects that are caused by neglect, misuse or mistreatment by an entity other than TI, including improper installation or testing, or for any EVMs that have been altered or modified in any way by an entity other than TI. Moreover, TI shall not be liable for any defects that result from User's design, specifications or instructions for such EVMs. Testing and other quality control techniques are used to the extent TI deems necessary or as mandated by government requirements. TI does not test all parameters of each EVM.
 - 2.3 If any EVM fails to conform to the warranty set forth above, TI's sole liability shall be at its option to repair or replace such EVM, or credit User's account for such EVM. TI's liability under this warranty shall be limited to EVMs that are returned during the warranty period to the address designated by TI and that are determined by TI not to conform to such warranty. If TI elects to repair or replace such EVM, TI shall have a reasonable time to repair such EVM or provide replacements. Repaired EVMs shall be warranted for the remainder of the original warranty period. Replaced EVMs shall be warranted for a new full ninety (90) day warranty period.
3. *Regulatory Notices:*
 - 3.1 *United States*
 - 3.1.1 *Notice applicable to EVMs not FCC-Approved:*

This kit is designed to allow product developers to evaluate electronic components, circuitry, or software associated with the kit to determine whether to incorporate such items in a finished product and software developers to write software applications for use with the end product. This kit is not a finished product and when assembled may not be resold or otherwise marketed unless all required FCC equipment authorizations are first obtained. Operation is subject to the condition that this product not cause harmful interference to licensed radio stations and that this product accept harmful interference. Unless the assembled kit is designed to operate under part 15, part 18 or part 95 of this chapter, the operator of the kit must operate under the authority of an FCC license holder or must secure an experimental authorization under part 5 of this chapter.
 - 3.1.2 *For EVMs annotated as FCC – FEDERAL COMMUNICATIONS COMMISSION Part 15 Compliant:*

CAUTION

This device complies with part 15 of the FCC Rules. Operation is subject to the following two conditions: (1) This device may not cause harmful interference, and (2) this device must accept any interference received, including interference that may cause undesired operation.

Changes or modifications not expressly approved by the party responsible for compliance could void the user's authority to operate the equipment.

FCC Interference Statement for Class A EVM devices

NOTE: This equipment has been tested and found to comply with the limits for a Class A digital device, pursuant to part 15 of the FCC Rules. These limits are designed to provide reasonable protection against harmful interference when the equipment is operated in a commercial environment. This equipment generates, uses, and can radiate radio frequency energy and, if not installed and used in accordance with the instruction manual, may cause harmful interference to radio communications. Operation of this equipment in a residential area is likely to cause harmful interference in which case the user will be required to correct the interference at his own expense.

FCC Interference Statement for Class B EVM devices

NOTE: This equipment has been tested and found to comply with the limits for a Class B digital device, pursuant to part 15 of the FCC Rules. These limits are designed to provide reasonable protection against harmful interference in a residential installation. This equipment generates, uses and can radiate radio frequency energy and, if not installed and used in accordance with the instructions, may cause harmful interference to radio communications. However, there is no guarantee that interference will not occur in a particular installation. If this equipment does cause harmful interference to radio or television reception, which can be determined by turning the equipment off and on, the user is encouraged to try to correct the interference by one or more of the following measures:

- Reorient or relocate the receiving antenna.
- Increase the separation between the equipment and receiver.
- Connect the equipment into an outlet on a circuit different from that to which the receiver is connected.
- Consult the dealer or an experienced radio/TV technician for help.

3.2 Canada

3.2.1 For EVMs issued with an Industry Canada Certificate of Conformance to RSS-210

Concerning EVMs Including Radio Transmitters:

This device complies with Industry Canada license-exempt RSS standard(s). Operation is subject to the following two conditions: (1) this device may not cause interference, and (2) this device must accept any interference, including interference that may cause undesired operation of the device.

Concernant les EVMs avec appareils radio:

Le présent appareil est conforme aux CNR d'Industrie Canada applicables aux appareils radio exempts de licence. L'exploitation est autorisée aux deux conditions suivantes: (1) l'appareil ne doit pas produire de brouillage, et (2) l'utilisateur de l'appareil doit accepter tout brouillage radioélectrique subi, même si le brouillage est susceptible d'en compromettre le fonctionnement.

Concerning EVMs Including Detachable Antennas:

Under Industry Canada regulations, this radio transmitter may only operate using an antenna of a type and maximum (or lesser) gain approved for the transmitter by Industry Canada. To reduce potential radio interference to other users, the antenna type and its gain should be so chosen that the equivalent isotropically radiated power (e.i.r.p.) is not more than that necessary for successful communication. This radio transmitter has been approved by Industry Canada to operate with the antenna types listed in the user guide with the maximum permissible gain and required antenna impedance for each antenna type indicated. Antenna types not included in this list, having a gain greater than the maximum gain indicated for that type, are strictly prohibited for use with this device.

Concernant les EVMs avec antennes détachables

Conformément à la réglementation d'Industrie Canada, le présent émetteur radio peut fonctionner avec une antenne d'un type et d'un gain maximal (ou inférieur) approuvé pour l'émetteur par Industrie Canada. Dans le but de réduire les risques de brouillage radioélectrique à l'intention des autres utilisateurs, il faut choisir le type d'antenne et son gain de sorte que la puissance isotrope rayonnée équivalente (p.i.r.e.) ne dépasse pas l'intensité nécessaire à l'établissement d'une communication satisfaisante. Le présent émetteur radio a été approuvé par Industrie Canada pour fonctionner avec les types d'antenne énumérés dans le manuel d'usage et ayant un gain admissible maximal et l'impédance requise pour chaque type d'antenne. Les types d'antenne non inclus dans cette liste, ou dont le gain est supérieur au gain maximal indiqué, sont strictement interdits pour l'exploitation de l'émetteur.

3.3 Japan

3.3.1 *Notice for EVMs delivered in Japan:* Please see http://www.tij.co.jp/lstds/ti_ja/general/eStore/notice_01.page 日本国内に輸入される評価用キット、ボードについては、次のところをご覧ください。
http://www.tij.co.jp/lstds/ti_ja/general/eStore/notice_01.page

3.3.2 *Notice for Users of EVMs Considered "Radio Frequency Products" in Japan:* EVMs entering Japan may not be certified by TI as conforming to Technical Regulations of Radio Law of Japan.

If User uses EVMs in Japan, not certified to Technical Regulations of Radio Law of Japan, User is required by Radio Law of Japan to follow the instructions below with respect to EVMs:

1. Use EVMs in a shielded room or any other test facility as defined in the notification #173 issued by Ministry of Internal Affairs and Communications on March 28, 2006, based on Sub-section 1.1 of Article 6 of the Ministry's Rule for Enforcement of Radio Law of Japan,
2. Use EVMs only after User obtains the license of Test Radio Station as provided in Radio Law of Japan with respect to EVMs, or
3. Use of EVMs only after User obtains the Technical Regulations Conformity Certification as provided in Radio Law of Japan with respect to EVMs. Also, do not transfer EVMs, unless User gives the same notice above to the transferee. Please note that if User does not follow the instructions above, User will be subject to penalties of Radio Law of Japan.

【無線電波を送信する製品の開発キットをお使いになる際の注意事項】 開発キットの中には技術基準適合証明を受けていないものがあります。技術適合証明を受けていないものご使用に際しては、電波法遵守のため、以下のいずれかの措置を取っていただく必要がありますのでご注意ください。

1. 電波法施行規則第6条第1項第1号に基づく平成18年3月28日総務省告示第173号で定められた電波暗室等の試験設備でご使用いただく。
2. 実験局の免許を取得後ご使用いただく。
3. 技術基準適合証明を取得後ご使用いただく。

なお、本製品は、上記の「ご使用にあたっての注意」を譲渡先、移転先に通知しない限り、譲渡、移転できないものとします。

上記を遵守頂けない場合は、電波法の罰則が適用される可能性があることをご留意ください。日本テキサス・インスツルメンツ株式会社
東京都新宿区西新宿 6 丁目 2 4 番 1 号
西新宿三井ビル

3.3.3 *Notice for EVMs for Power Line Communication:* Please see http://www.tij.co.jp/llds/ti_ja/general/eStore/notice_02.page
電力線搬送波通信についての開発キットをお使いになる際の注意事項については、次のところをご覧ください。http://www.tij.co.jp/llds/ti_ja/general/eStore/notice_02.page

4 *EVM Use Restrictions and Warnings:*

4.1 EVMS ARE NOT FOR USE IN FUNCTIONAL SAFETY AND/OR SAFETY CRITICAL EVALUATIONS, INCLUDING BUT NOT LIMITED TO EVALUATIONS OF LIFE SUPPORT APPLICATIONS.

4.2 User must read and apply the user guide and other available documentation provided by TI regarding the EVM prior to handling or using the EVM, including without limitation any warning or restriction notices. The notices contain important safety information related to, for example, temperatures and voltages.

4.3 *Safety-Related Warnings and Restrictions:*

4.3.1 User shall operate the EVM within TI's recommended specifications and environmental considerations stated in the user guide, other available documentation provided by TI, and any other applicable requirements and employ reasonable and customary safeguards. Exceeding the specified performance ratings and specifications (including but not limited to input and output voltage, current, power, and environmental ranges) for the EVM may cause personal injury or death, or property damage. If there are questions concerning performance ratings and specifications, User should contact a TI field representative prior to connecting interface electronics including input power and intended loads. Any loads applied outside of the specified output range may also result in unintended and/or inaccurate operation and/or possible permanent damage to the EVM and/or interface electronics. Please consult the EVM user guide prior to connecting any load to the EVM output. If there is uncertainty as to the load specification, please contact a TI field representative. During normal operation, even with the inputs and outputs kept within the specified allowable ranges, some circuit components may have elevated case temperatures. These components include but are not limited to linear regulators, switching transistors, pass transistors, current sense resistors, and heat sinks, which can be identified using the information in the associated documentation. When working with the EVM, please be aware that the EVM may become very warm.

4.3.2 EVMs are intended solely for use by technically qualified, professional electronics experts who are familiar with the dangers and application risks associated with handling electrical mechanical components, systems, and subsystems. User assumes all responsibility and liability for proper and safe handling and use of the EVM by User or its employees, affiliates, contractors or designees. User assumes all responsibility and liability to ensure that any interfaces (electronic and/or mechanical) between the EVM and any human body are designed with suitable isolation and means to safely limit accessible leakage currents to minimize the risk of electrical shock hazard. User assumes all responsibility and liability for any improper or unsafe handling or use of the EVM by User or its employees, affiliates, contractors or designees.

4.4 User assumes all responsibility and liability to determine whether the EVM is subject to any applicable international, federal, state, or local laws and regulations related to User's handling and use of the EVM and, if applicable, User assumes all responsibility and liability for compliance in all respects with such laws and regulations. User assumes all responsibility and liability for proper disposal and recycling of the EVM consistent with all applicable international, federal, state, and local requirements.

5. *Accuracy of Information:* To the extent TI provides information on the availability and function of EVMs, TI attempts to be as accurate as possible. However, TI does not warrant the accuracy of EVM descriptions, EVM availability or other information on its websites as accurate, complete, reliable, current, or error-free.

6. *Disclaimers:*
- 6.1 EXCEPT AS SET FORTH ABOVE, EVMS AND ANY WRITTEN DESIGN MATERIALS PROVIDED WITH THE EVM (AND THE DESIGN OF THE EVM ITSELF) ARE PROVIDED "AS IS" AND "WITH ALL FAULTS." TI DISCLAIMS ALL OTHER WARRANTIES, EXPRESS OR IMPLIED, REGARDING SUCH ITEMS, INCLUDING BUT NOT LIMITED TO ANY IMPLIED WARRANTIES OF MERCHANTABILITY OR FITNESS FOR A PARTICULAR PURPOSE OR NON-INFRINGEMENT OF ANY THIRD PARTY PATENTS, COPYRIGHTS, TRADE SECRETS OR OTHER INTELLECTUAL PROPERTY RIGHTS.
- 6.2 EXCEPT FOR THE LIMITED RIGHT TO USE THE EVM SET FORTH HEREIN, NOTHING IN THESE TERMS AND CONDITIONS SHALL BE CONSTRUED AS GRANTING OR CONFERRING ANY RIGHTS BY LICENSE, PATENT, OR ANY OTHER INDUSTRIAL OR INTELLECTUAL PROPERTY RIGHT OF TI, ITS SUPPLIERS/LICENSORS OR ANY OTHER THIRD PARTY, TO USE THE EVM IN ANY FINISHED END-USER OR READY-TO-USE FINAL PRODUCT, OR FOR ANY INVENTION, DISCOVERY OR IMPROVEMENT MADE, CONCEIVED OR ACQUIRED PRIOR TO OR AFTER DELIVERY OF THE EVM.
7. *USER'S INDEMNITY OBLIGATIONS AND REPRESENTATIONS.* USER WILL DEFEND, INDEMNIFY AND HOLD TI, ITS LICENSORS AND THEIR REPRESENTATIVES HARMLESS FROM AND AGAINST ANY AND ALL CLAIMS, DAMAGES, LOSSES, EXPENSES, COSTS AND LIABILITIES (COLLECTIVELY, "CLAIMS") ARISING OUT OF OR IN CONNECTION WITH ANY HANDLING OR USE OF THE EVM THAT IS NOT IN ACCORDANCE WITH THESE TERMS AND CONDITIONS. THIS OBLIGATION SHALL APPLY WHETHER CLAIMS ARISE UNDER STATUTE, REGULATION, OR THE LAW OF TORT, CONTRACT OR ANY OTHER LEGAL THEORY, AND EVEN IF THE EVM FAILS TO PERFORM AS DESCRIBED OR EXPECTED.
8. *Limitations on Damages and Liability:*
- 8.1 *General Limitations.* IN NO EVENT SHALL TI BE LIABLE FOR ANY SPECIAL, COLLATERAL, INDIRECT, PUNITIVE, INCIDENTAL, CONSEQUENTIAL, OR EXEMPLARY DAMAGES IN CONNECTION WITH OR ARISING OUT OF THESE TERMS AND CONDITIONS OR THE USE OF THE EVMS PROVIDED HEREUNDER, REGARDLESS OF WHETHER TI HAS BEEN ADVISED OF THE POSSIBILITY OF SUCH DAMAGES. EXCLUDED DAMAGES INCLUDE, BUT ARE NOT LIMITED TO, COST OF REMOVAL OR REINSTALLATION, ANCILLARY COSTS TO THE PROCUREMENT OF SUBSTITUTE GOODS OR SERVICES, RETESTING, OUTSIDE COMPUTER TIME, LABOR COSTS, LOSS OF GOODWILL, LOSS OF PROFITS, LOSS OF SAVINGS, LOSS OF USE, LOSS OF DATA, OR BUSINESS INTERRUPTION. NO CLAIM, SUIT OR ACTION SHALL BE BROUGHT AGAINST TI MORE THAN ONE YEAR AFTER THE RELATED CAUSE OF ACTION HAS OCCURRED.
- 8.2 *Specific Limitations.* IN NO EVENT SHALL TI'S AGGREGATE LIABILITY FROM ANY WARRANTY OR OTHER OBLIGATION ARISING OUT OF OR IN CONNECTION WITH THESE TERMS AND CONDITIONS, OR ANY USE OF ANY TI EVM PROVIDED HEREUNDER, EXCEED THE TOTAL AMOUNT PAID TO TI FOR THE PARTICULAR UNITS SOLD UNDER THESE TERMS AND CONDITIONS WITH RESPECT TO WHICH LOSSES OR DAMAGES ARE CLAIMED. THE EXISTENCE OF MORE THAN ONE CLAIM AGAINST THE PARTICULAR UNITS SOLD TO USER UNDER THESE TERMS AND CONDITIONS SHALL NOT ENLARGE OR EXTEND THIS LIMIT.
9. *Return Policy.* Except as otherwise provided, TI does not offer any refunds, returns, or exchanges. Furthermore, no return of EVM(s) will be accepted if the package has been opened and no return of the EVM(s) will be accepted if they are damaged or otherwise not in a resalable condition. If User feels it has been incorrectly charged for the EVM(s) it ordered or that delivery violates the applicable order, User should contact TI. All refunds will be made in full within thirty (30) working days from the return of the components(s), excluding any postage or packaging costs.
10. *Governing Law:* These terms and conditions shall be governed by and interpreted in accordance with the laws of the State of Texas, without reference to conflict-of-laws principles. User agrees that non-exclusive jurisdiction for any dispute arising out of or relating to these terms and conditions lies within courts located in the State of Texas and consents to venue in Dallas County, Texas. Notwithstanding the foregoing, any judgment may be enforced in any United States or foreign court, and TI may seek injunctive relief in any United States or foreign court.

Mailing Address: Texas Instruments, Post Office Box 655303, Dallas, Texas 75265
Copyright © 2015, Texas Instruments Incorporated

IMPORTANT NOTICE

Texas Instruments Incorporated and its subsidiaries (TI) reserve the right to make corrections, enhancements, improvements and other changes to its semiconductor products and services per JESD46, latest issue, and to discontinue any product or service per JESD48, latest issue. Buyers should obtain the latest relevant information before placing orders and should verify that such information is current and complete. All semiconductor products (also referred to herein as "components") are sold subject to TI's terms and conditions of sale supplied at the time of order acknowledgment.

TI warrants performance of its components to the specifications applicable at the time of sale, in accordance with the warranty in TI's terms and conditions of sale of semiconductor products. Testing and other quality control techniques are used to the extent TI deems necessary to support this warranty. Except where mandated by applicable law, testing of all parameters of each component is not necessarily performed.

TI assumes no liability for applications assistance or the design of Buyers' products. Buyers are responsible for their products and applications using TI components. To minimize the risks associated with Buyers' products and applications, Buyers should provide adequate design and operating safeguards.

TI does not warrant or represent that any license, either express or implied, is granted under any patent right, copyright, mask work right, or other intellectual property right relating to any combination, machine, or process in which TI components or services are used. Information published by TI regarding third-party products or services does not constitute a license to use such products or services or a warranty or endorsement thereof. Use of such information may require a license from a third party under the patents or other intellectual property of the third party, or a license from TI under the patents or other intellectual property of TI.

Reproduction of significant portions of TI information in TI data books or data sheets is permissible only if reproduction is without alteration and is accompanied by all associated warranties, conditions, limitations, and notices. TI is not responsible or liable for such altered documentation. Information of third parties may be subject to additional restrictions.

Resale of TI components or services with statements different from or beyond the parameters stated by TI for that component or service voids all express and any implied warranties for the associated TI component or service and is an unfair and deceptive business practice. TI is not responsible or liable for any such statements.

Buyer acknowledges and agrees that it is solely responsible for compliance with all legal, regulatory and safety-related requirements concerning its products, and any use of TI components in its applications, notwithstanding any applications-related information or support that may be provided by TI. Buyer represents and agrees that it has all the necessary expertise to create and implement safeguards which anticipate dangerous consequences of failures, monitor failures and their consequences, lessen the likelihood of failures that might cause harm and take appropriate remedial actions. Buyer will fully indemnify TI and its representatives against any damages arising out of the use of any TI components in safety-critical applications.

In some cases, TI components may be promoted specifically to facilitate safety-related applications. With such components, TI's goal is to help enable customers to design and create their own end-product solutions that meet applicable functional safety standards and requirements. Nonetheless, such components are subject to these terms.

No TI components are authorized for use in FDA Class III (or similar life-critical medical equipment) unless authorized officers of the parties have executed a special agreement specifically governing such use.

Only those TI components which TI has specifically designated as military grade or "enhanced plastic" are designed and intended for use in military/aerospace applications or environments. Buyer acknowledges and agrees that any military or aerospace use of TI components which have **not** been so designated is solely at the Buyer's risk, and that Buyer is solely responsible for compliance with all legal and regulatory requirements in connection with such use.

TI has specifically designated certain components as meeting ISO/TS16949 requirements, mainly for automotive use. In any case of use of non-designated products, TI will not be responsible for any failure to meet ISO/TS16949.

Products

Audio	www.ti.com/audio
Amplifiers	amplifier.ti.com
Data Converters	dataconverter.ti.com
DLP® Products	www.dlp.com
DSP	dsp.ti.com
Clocks and Timers	www.ti.com/clocks
Interface	interface.ti.com
Logic	logic.ti.com
Power Mgmt	power.ti.com
Microcontrollers	microcontroller.ti.com
RFID	www.ti-rfid.com
OMAP Applications Processors	www.ti.com/omap
Wireless Connectivity	www.ti.com/wirelessconnectivity

Applications

Automotive and Transportation	www.ti.com/automotive
Communications and Telecom	www.ti.com/communications
Computers and Peripherals	www.ti.com/computers
Consumer Electronics	www.ti.com/consumer-apps
Energy and Lighting	www.ti.com/energy
Industrial	www.ti.com/industrial
Medical	www.ti.com/medical
Security	www.ti.com/security
Space, Avionics and Defense	www.ti.com/space-avionics-defense
Video and Imaging	www.ti.com/video

TI E2E Community

e2e.ti.com