

| LOC | | DIST | | REVISIONS | | | |
|-----|----|------|-----|---------------------------|-----------|-----|------|
| GP | 00 | P | LTN | DESCRIPTION | DATE | DWN | APVD |
| | | B | | REVISED PER ECO-15-017919 | 04APR2016 | AP | RP |
| | | B1 | | ADD PN 2149490-9 | 17JUN2020 | IT | SH |

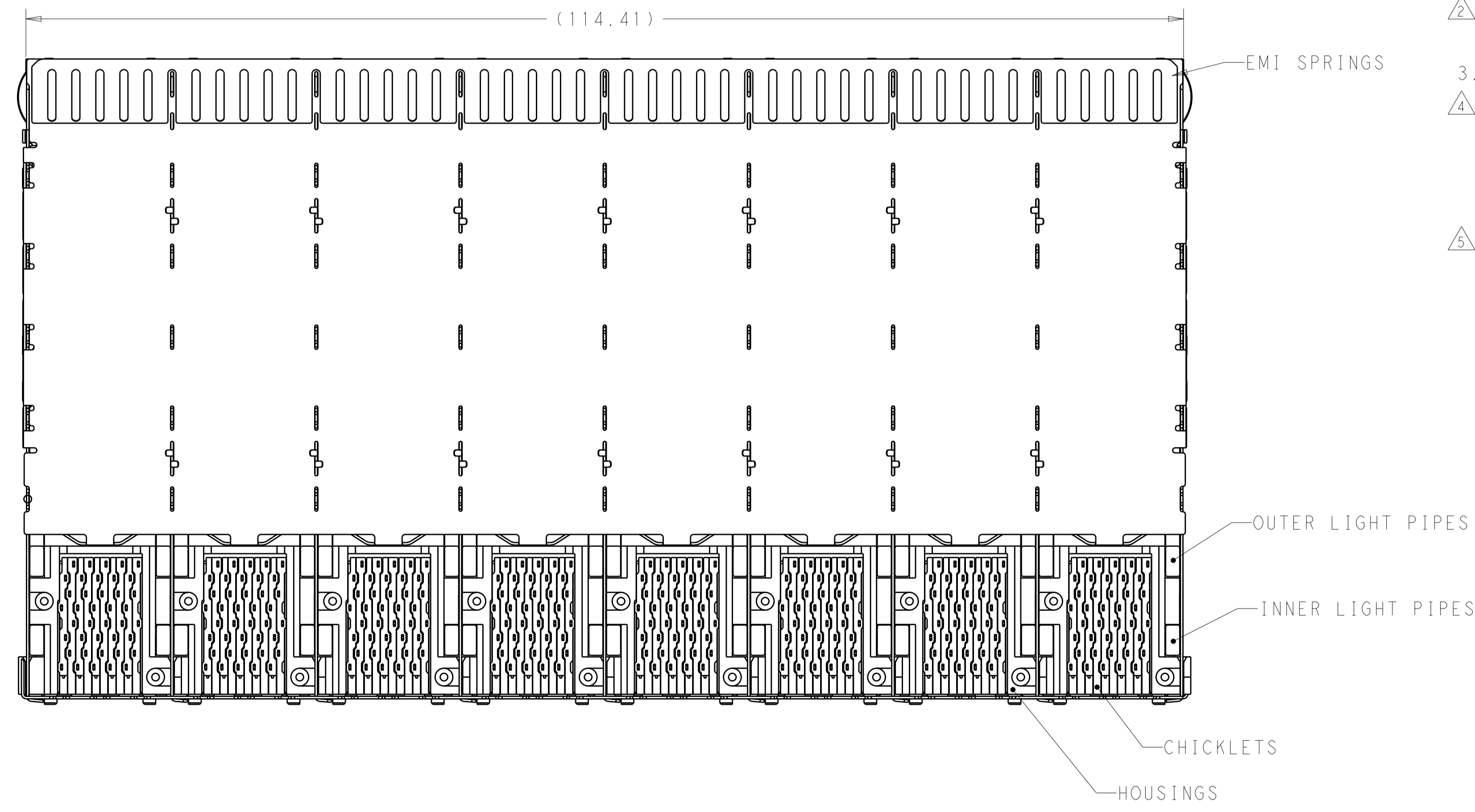
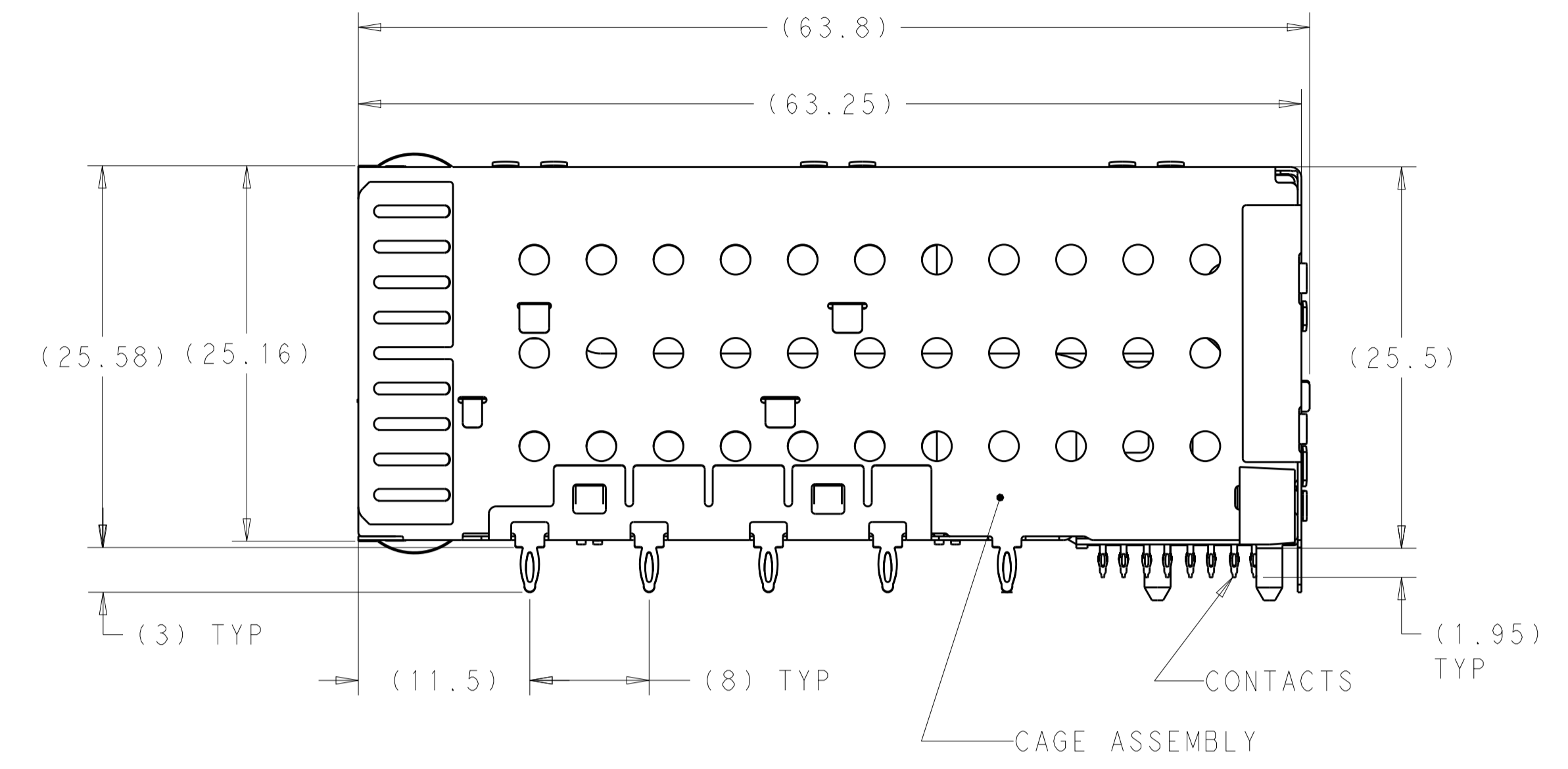
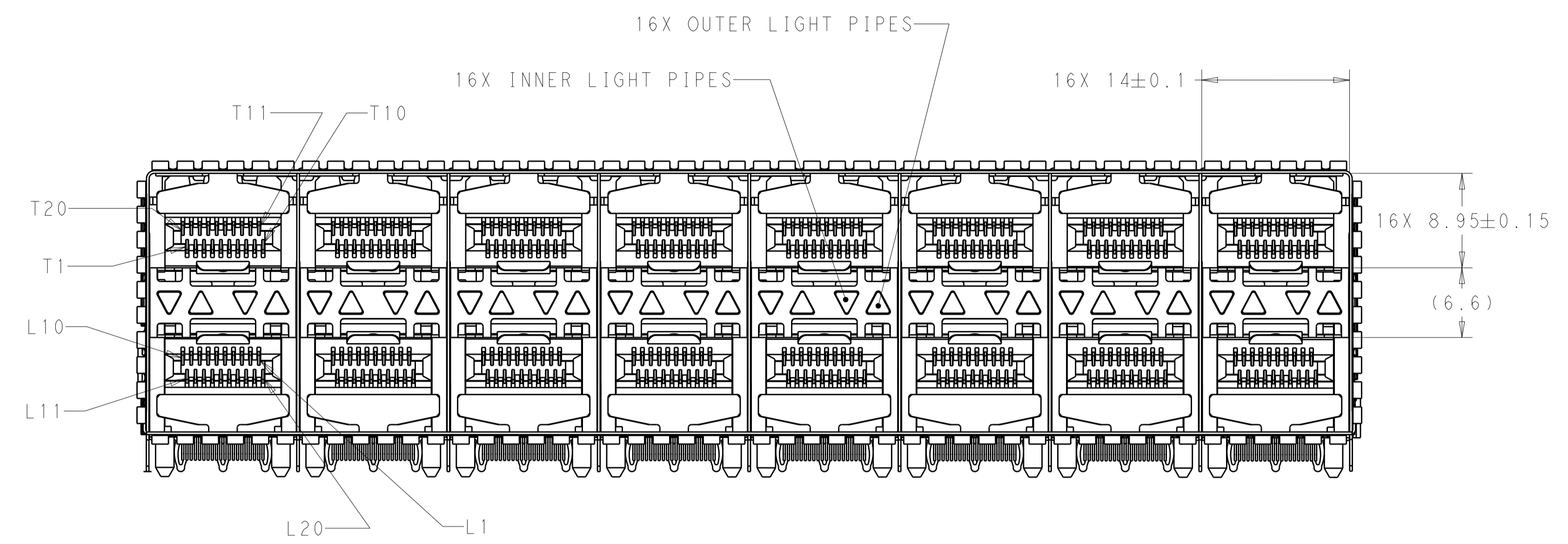

- ⚠ MATERIALS:
 CAGE ASSEMBLY- NICKEL SILVER ALLOY PER ASTM B 122.
 EMI SPRINGS- COPPER ALLOY.
 HOUSING- BLACK LCP, UL 94V-0 RATED.
 CHICKLET- BLACK LCP, UL 94V-0 RATED.
 LIGHT PIPE- POLYCARBONATE, CLEAR.
 CONTACT- COPPER ALLOY.
- ⚠ DATUM AND BASIC DIMENSIONS ESTABLISHED BY CUSTOMER.
- 3. MINIMUM PCB THICKNESS OF 1.5.
- ⚠ CONTACT FINISH- CONFORMS TO THE REQUIREMENTS OF TYCO ELECTRONICS PRODUCT SPECIFICATION 108-2331, BASED ON EIA/ECA-364-1000.01A, (CONTROLLED ENVIRONMENT APPLICATIONS) ON MATING INTERFACE, TIN-LEAD ON NEEDLE EYE.
- ⚠ CONTACT FINISH- CONFORMS TO THE REQUIREMENTS OF TYCO ELECTRONICS PRODUCT SPECIFICATION 108-2331, BASED ON EIA/ECA-364-1000.01A, (CONTROLLED ENVIRONMENT APPLICATIONS) ON MATING INTERFACE, TIN ON NEEDLE EYE.
- ⚠ FOR HOLE SIZE AND PLATINGS, SEE APPLICATION SPEC 114-13219.
- ⚠ THE ENTIRE AREA OF THE CONNECTOR FOOTPRINT, INDICATED BY THE DASHE LINE, TO BE CONSIDERED THE KEEPCUT AREA FOR COMPONENTS AND SIGNAL TRACES, TOP SIDE ONLY. TOP SIDE TRACES ALLOWED WITHIN CONNECTOR HOLE PATTERN.
- ⚠ LIGHT PIPE PAD LAYOUT IS FOR 0805 LOW PROFILE LED PACKAGE WITH A HEIGHT OF 0.8mm.
- ⚠ EMI SPRING FINISH: 0.8µm MINIMUM MATTE TIN OVER 0.8µm MINIMUM NICKEL, NONPLATED EDGES PERMISSIBLE.
- ⚠ ADDITIONAL COMPONENT LOCATED WITHIN LATCH PLATE FOR EMI SUPPRESSION.
- ⚠ EMI SPRING WELDING REINFORCED WITH MORE WELDING DOTS.

| YES | NO | SUPERSEDED | ENHANCED EMI | FINISH | DESCRIPTION | PART NUMBER |
|-----|----|------------|--------------|--------|---------------------|-------------|
| ⚠ | ⚠ | ⚠ | ⚠ | ⚠ | NO LIGHT PIPES | 1-2149490-8 |
| | | | | | OUTER 2 LIGHT PIPES | 1-2149490-7 |
| | | | | | INNER 2 LIGHT PIPES | 1-2149490-6 |
| | | | | | 4 LIGHT PIPES | 1-2149490-5 |
| ⚠ | ⚠ | ⚠ | ⚠ | ⚠ | INNER 2 LIGHT PIPES | 2149490-9 ⚠ |
| | | | | | NO LIGHT PIPES | 2149490-8 |
| | | | | | OUTER 2 LIGHT PIPES | 2149490-7 |
| | | | | | INNER 2 LIGHT PIPES | 2149490-6 |
| ⚠ | ⚠ | ⚠ | ⚠ | ⚠ | 4 LIGHT PIPES | 2149490-5 |
| | | | | | NO LIGHT PIPES | 2149490-4 |
| | | | | | OUTER 2 LIGHT PIPES | 2149490-3 |
| | | | | | INNER 2 LIGHT PIPES | 2149490-2 |
| ⚠ | ⚠ | ⚠ | ⚠ | ⚠ | 4 LIGHT PIPES | 2149490-1 |

THIS DRAWING IS A CONTROLLED DOCUMENT. DIMENSIONING AND TOLERANCING PER ASME Y14.5M-2009.

DIMENSIONS: mm

TOLERANCES UNLESS OTHERWISE SPECIFIED:

| | |
|--------|-------|
| 0 PLC | ± |
| 1 PLC | ±0.10 |
| 2 PLC | ±0.10 |
| 3 PLC | ±0.10 |
| 4 PLC | ±0.10 |
| ANGLES | ±0.10 |

MATERIAL: 1

FINISH: 4 5 9

OWN: C. VALENTINE 08OCT2010
 CHK: J. PETERSON 08OCT2010
 APVD: J. PETERSON 08OCT2010

NAME: CAGE AND PT CONNECTOR ASSEMBLY, WITH EMI SPRINGS, PRESS FIT, 2X8, STACKED SFP+

PRODUCT SPEC: 108-2331
 APPLICATION SPEC: 114-13219

SIZE: CAGE CODE DRAWING NO: A100779
 WEIGHT: C=2149490

CUSTOMER DRAWING

SCALE: 3:1 SHEET 1 OF 4 REV: B1

STE TE Connectivity

| LOC | | DIST | | REVISIONS | | | |
|-----|-----|-------------|------|-----------|------|--|--|
| P | LTN | DESCRIPTION | DATE | DWN | APVD | | |
| | | | | | | | |

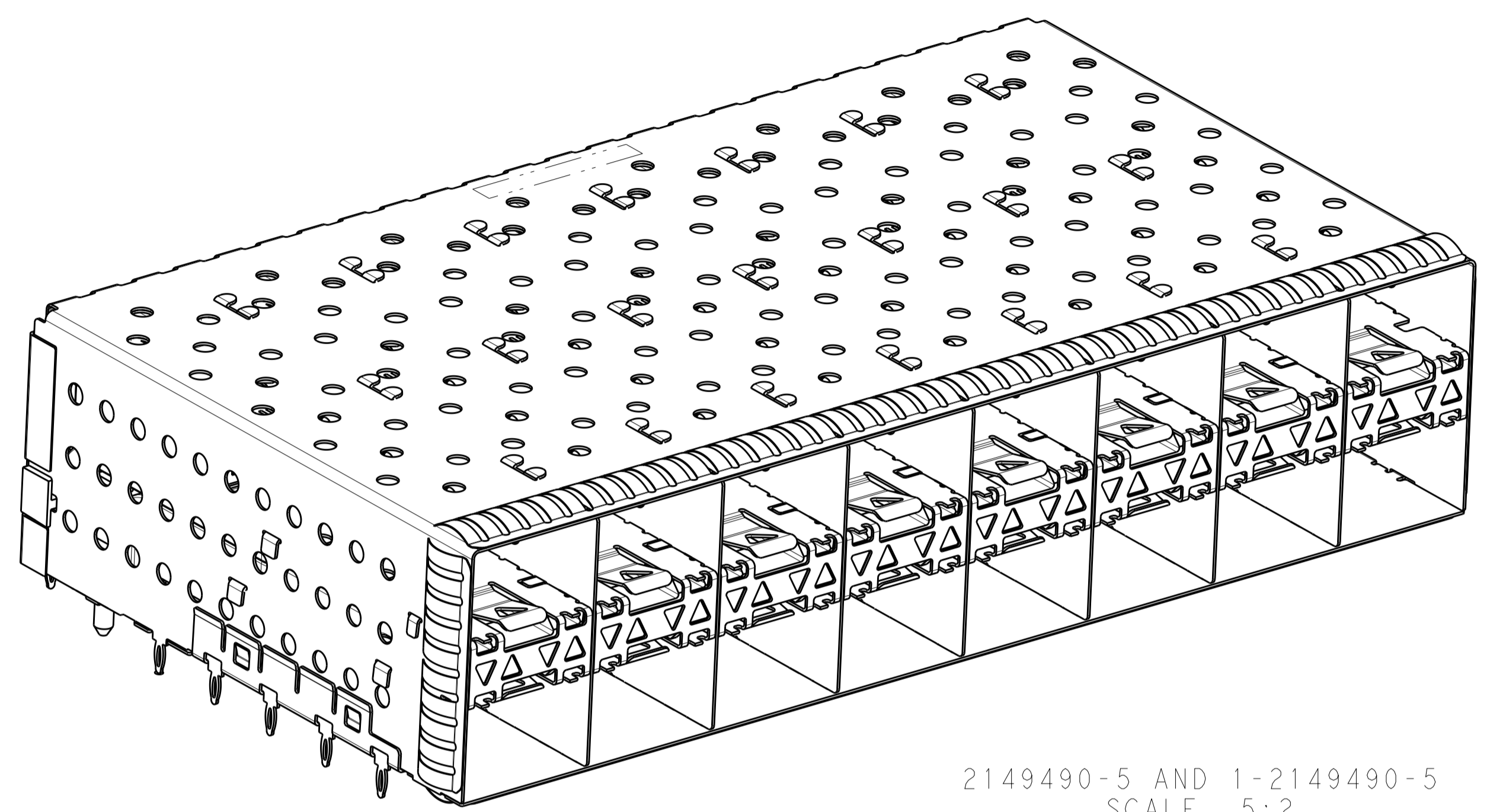

2149490-5 AND 1-2149490-5
 SCALE 5:2

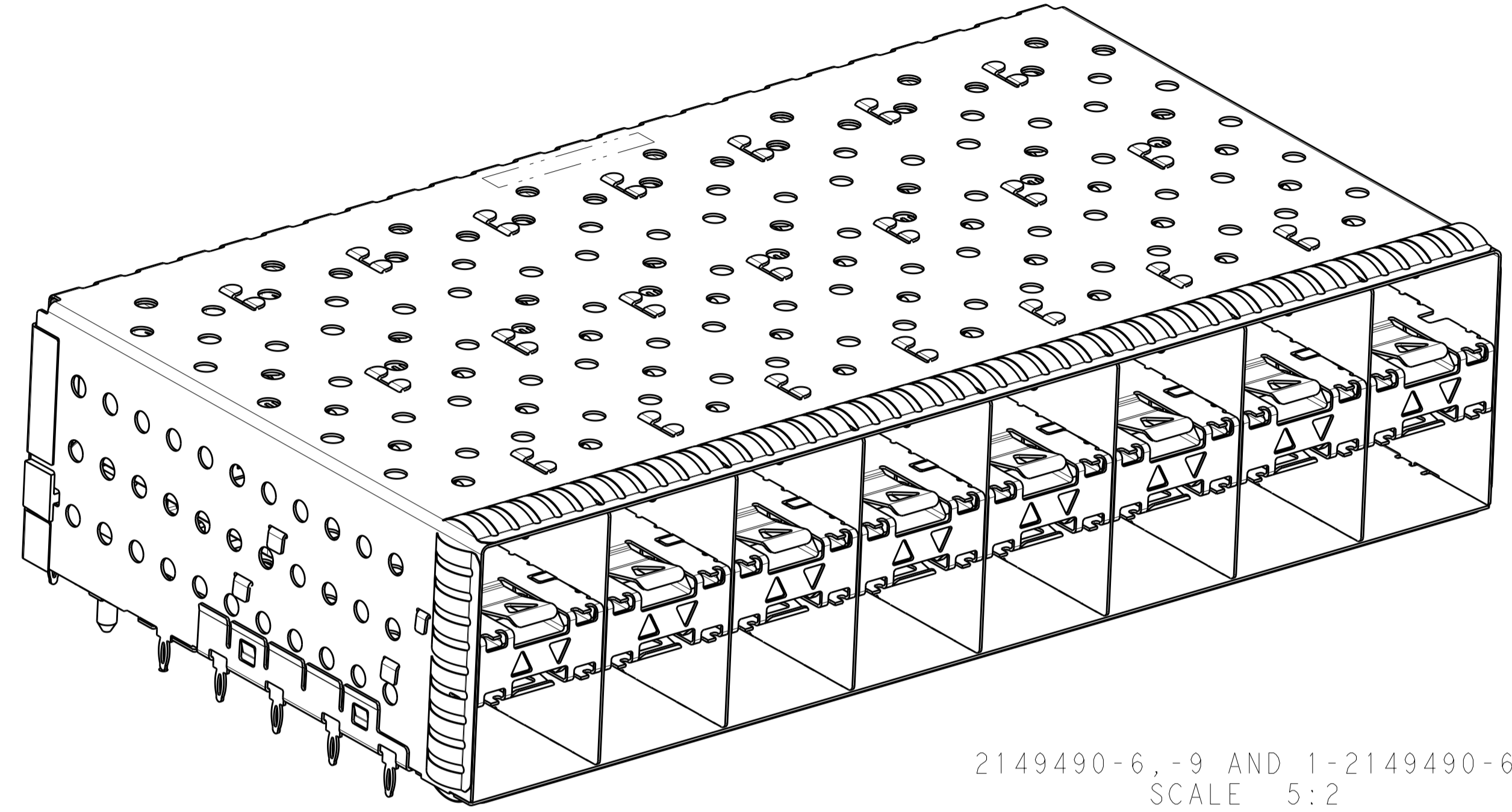

2149490-6, -9 AND 1-2149490-6
 SCALE 5:2

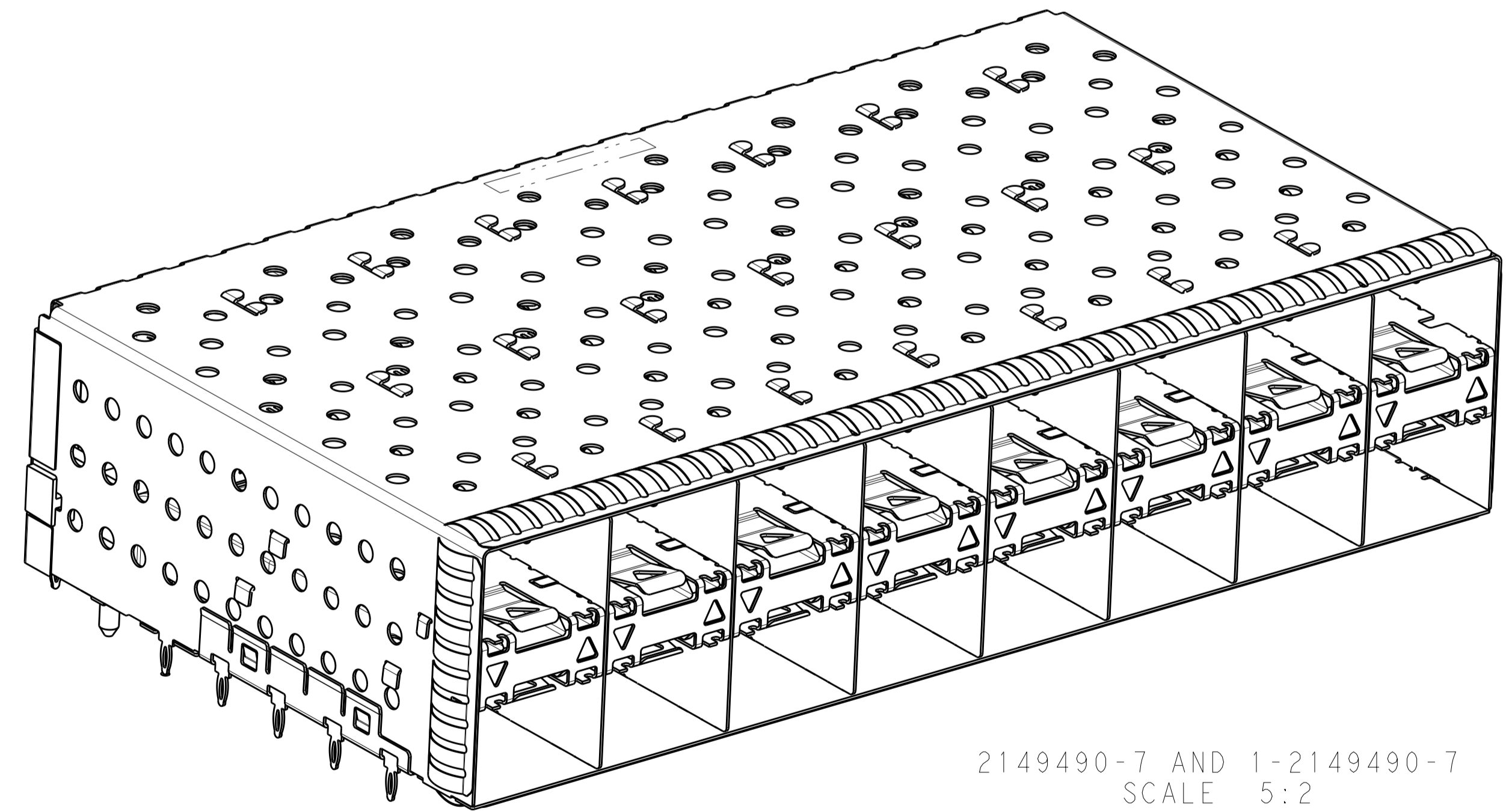

2149490-7 AND 1-2149490-7
 SCALE 5:2

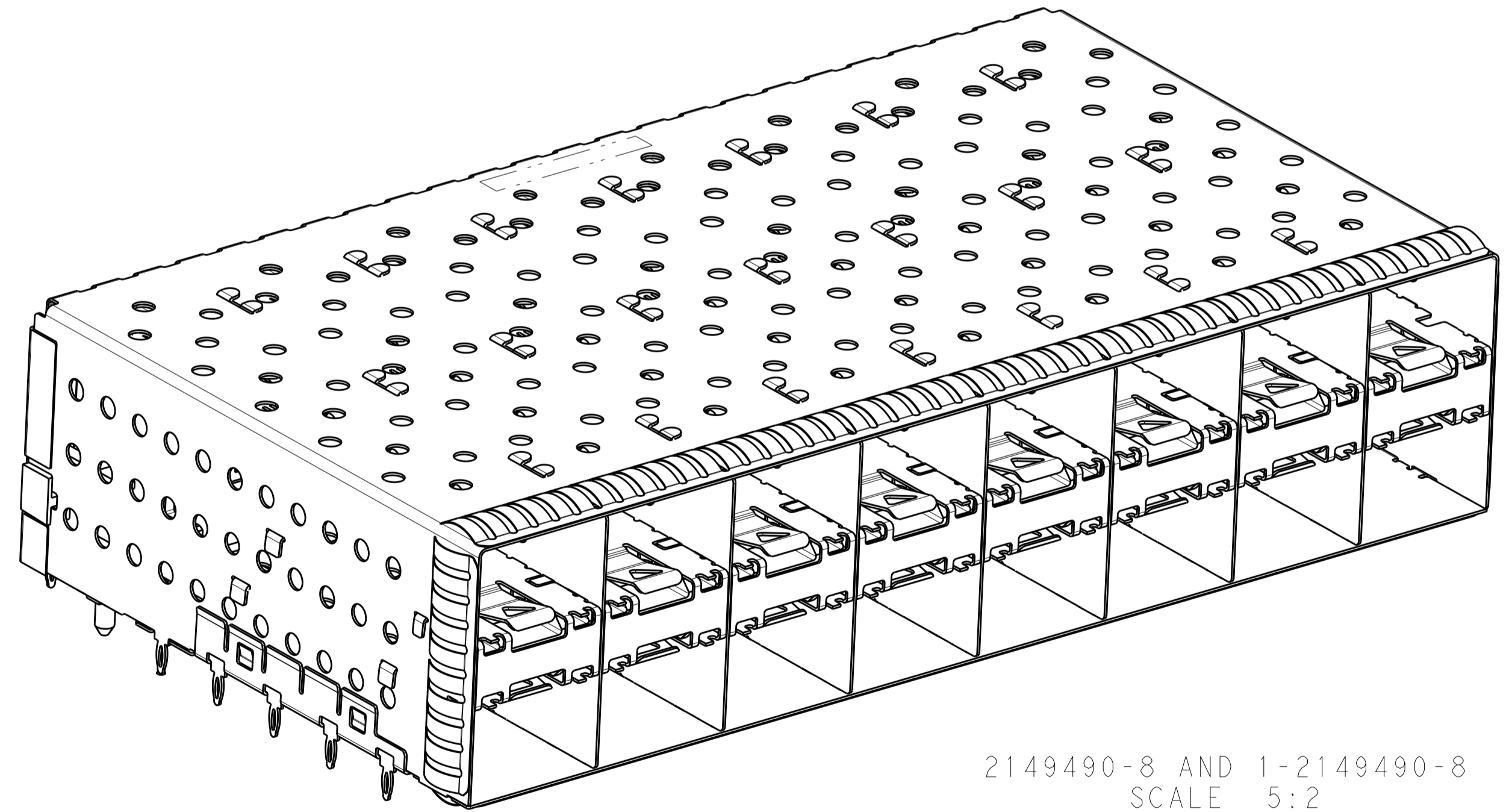

2149490-8 AND 1-2149490-8
 SCALE 5:2

| | | | |
|---|--------|----------------------------------|---|
| THIS DRAWING IS A CONTROLLED DOCUMENT. DIMENSIONING AND TOLERANCING PER ASME Y14.5M-2009. | | DWN C. VALENTINE 08OCT2010 |  TE Connectivity |
| DIMENSIONS: mm | | CHK J. PETERSON 08OCT2010 | |
| TOLERANCES UNLESS OTHERWISE SPECIFIED: | | APVD J. PETERSON 08OCT2010 | NAME CAGE AND PT CONNECTOR ASSEMBLY, WITH EMI SPRINGS, PRESS FIT, 2X8, STACKED SFP+ |
| 0 PLC | ± | PRODUCT SPEC | SIZE 108-2331 |
| 1 PLC | ±0.10 | APPLICATION SPEC | RESTRICTED TO |
| 2 PLC | ±0.10 | 114-13219 | A100779C=2149490 |
| 3 PLC | ±0.10 | WEIGHT | SCALE 3:1 SHEET 2 OF 4 REV B1 |
| 4 PLC | ±0.10 | CUSTOMER DRAWING | |
| ANGLES | ± | | |
| MATERIAL | FINISH | | |

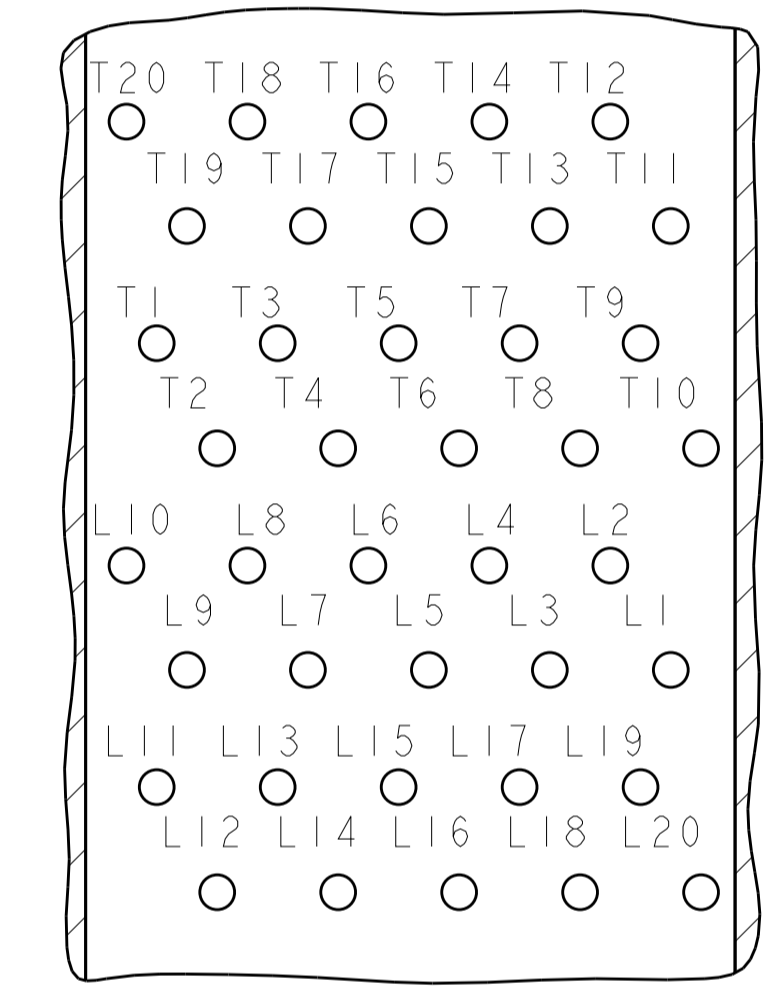
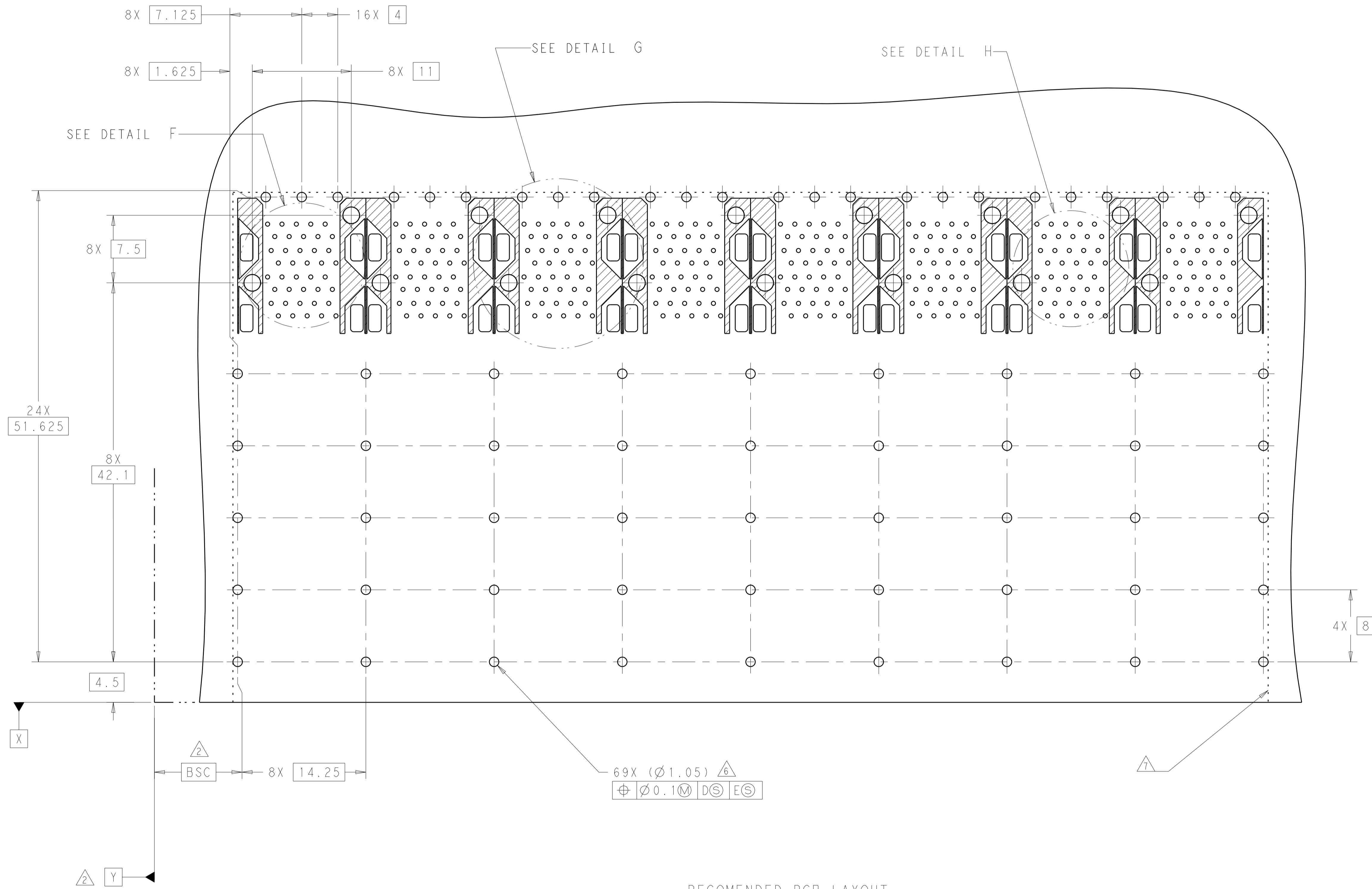

DETAIL H
 CONNECTOR PIN-OUT
 COMPONENT SIDE OF BOARD
 8X INDIVIDUALLY
 SCALE 10:1

RECOMENDED PCB LAYOUT
 COMPONENT SIDE OF THE BOARD
 SCALE 4:1

| | | | |
|---|--|--|--|
| THIS DRAWING IS A CONTROLLED DOCUMENT. DIMENSIONING AND TOLERANCING PER ASME Y14.5M-2009. | | DMN C. VALENTINE 08OCT2010 | TE Connectivity |
| DIMENSIONS: mm | | CHK J. PETERSON 08OCT2010 | |
| TOLERANCES UNLESS OTHERWISE SPECIFIED: | | APVD J. PETERSON 08OCT2010 | NAME CAGE AND PT CONNECTOR ASSEMBLY, WITH EMI SPRINGS, PRESS FIT, 2X8, STACKED SFP+ |
| 0 PLC ±.10 1 PLC ±0.10 2 PLC ±0.10 3 PLC ±0.10 4 PLC ±0.10 ANGLES ±.10 FINISH | | PRODUCT SPEC 108-2331 APPLICATION SPEC 114-13219 WEIGHT - | |
| MATERIAL | | SIZE A100779C=2149490 CUSTOMER DRAWING | RESTRICTED TO - SCALE 3:1 SHEET 3 OF 4 REV B1 |

| LOC | DIST | REVISIONS | DATE | OWN | APVD |
|-----|------|-------------|------|-----|------|
| | | SEE SHEET 1 | | | |

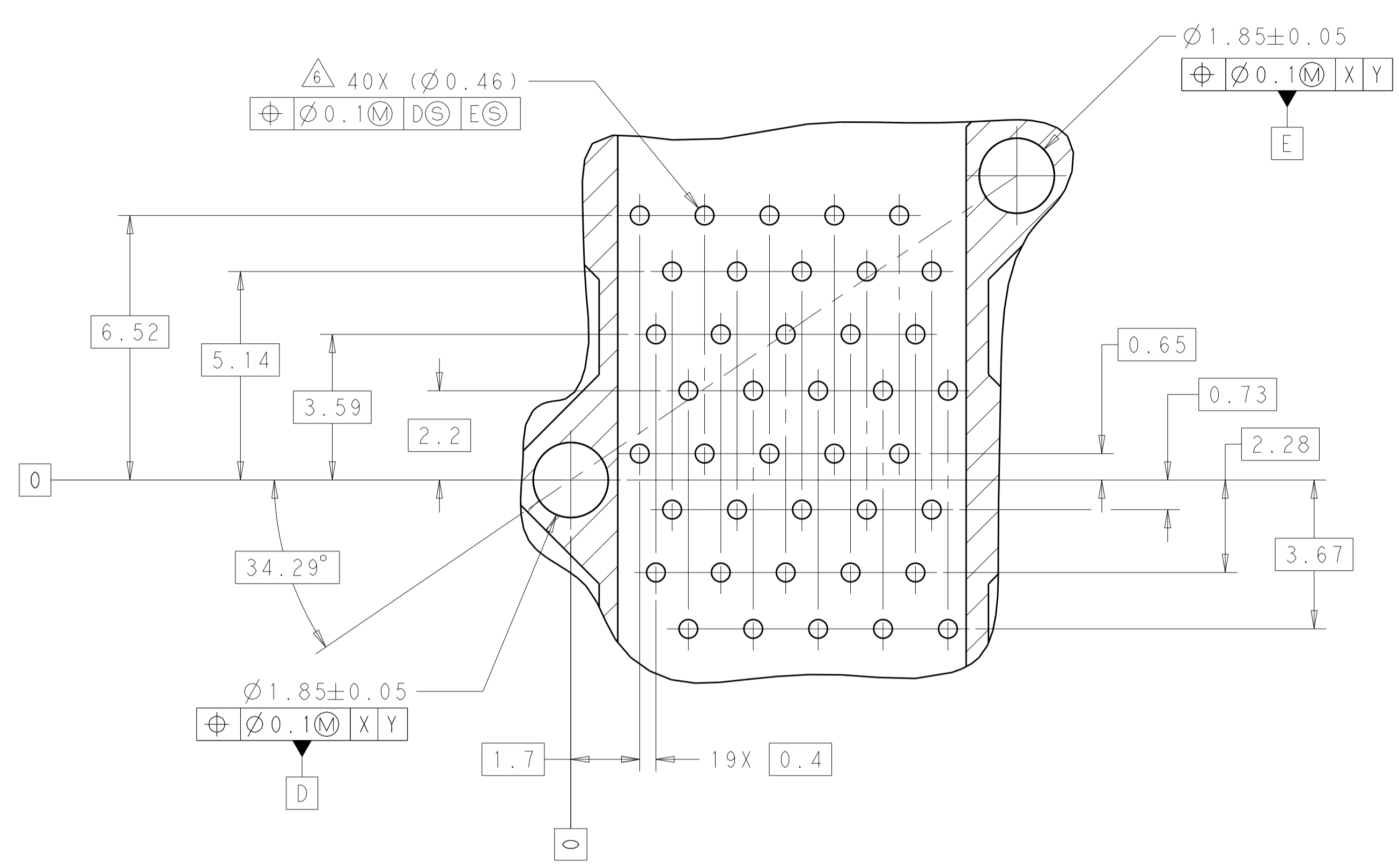

DETAIL F
8X INDIVIDUALLY
SCALE 10:1

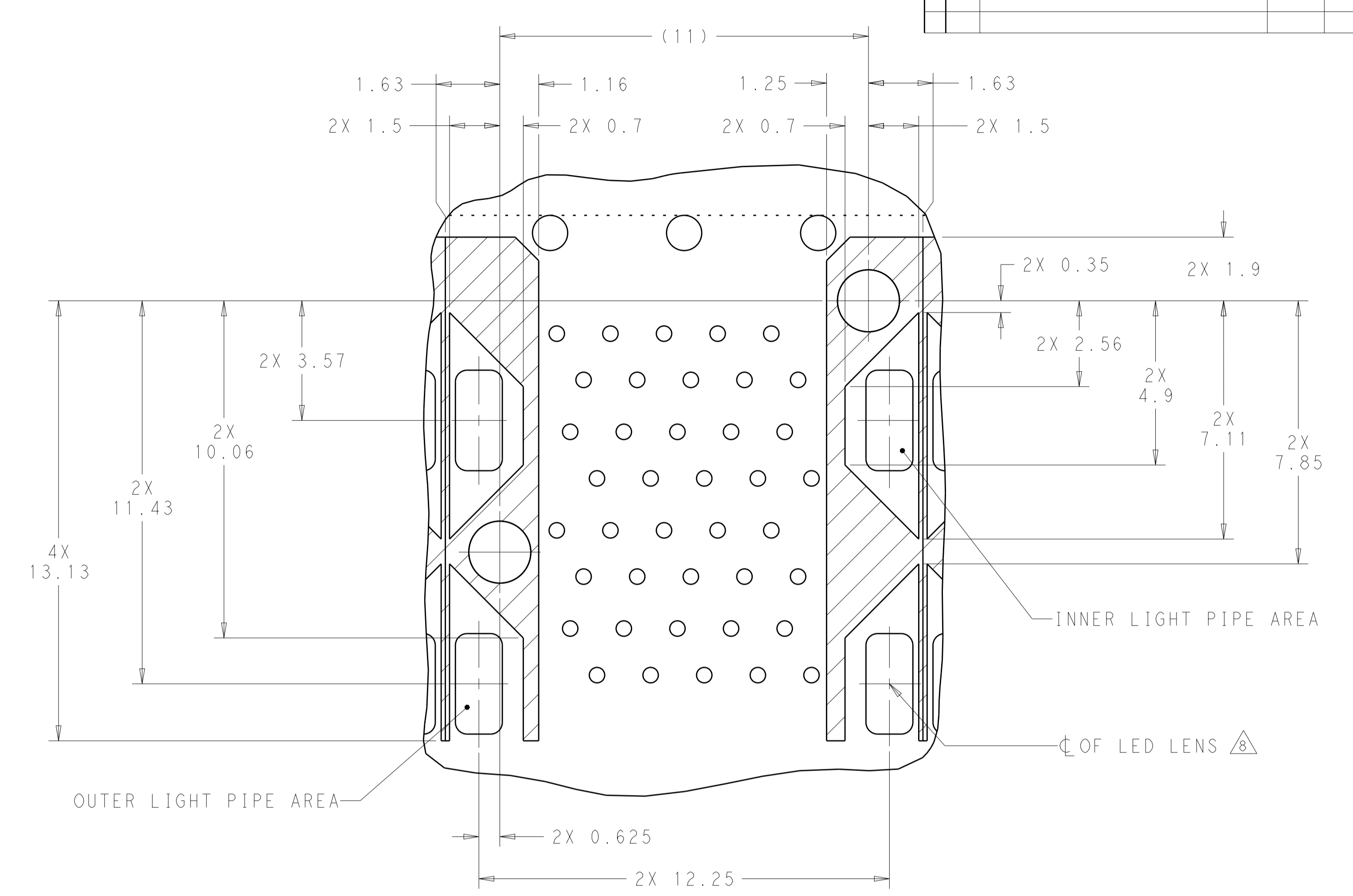

DETAIL G
CONNECTOR HOUSING
KEEP-OUT ZONE
8X INDIVIDUALLY
SCALE 10:1

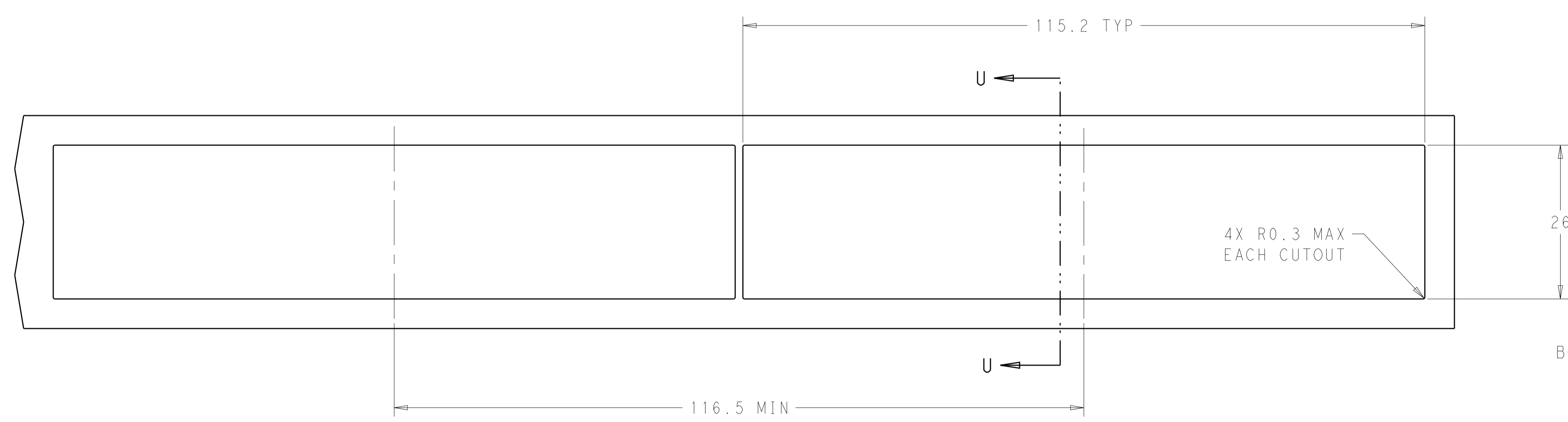

RECOMMENDED PANEL CUTOUT
AND PC BOARD, PANEL LAYOUT
SCALE 2:1

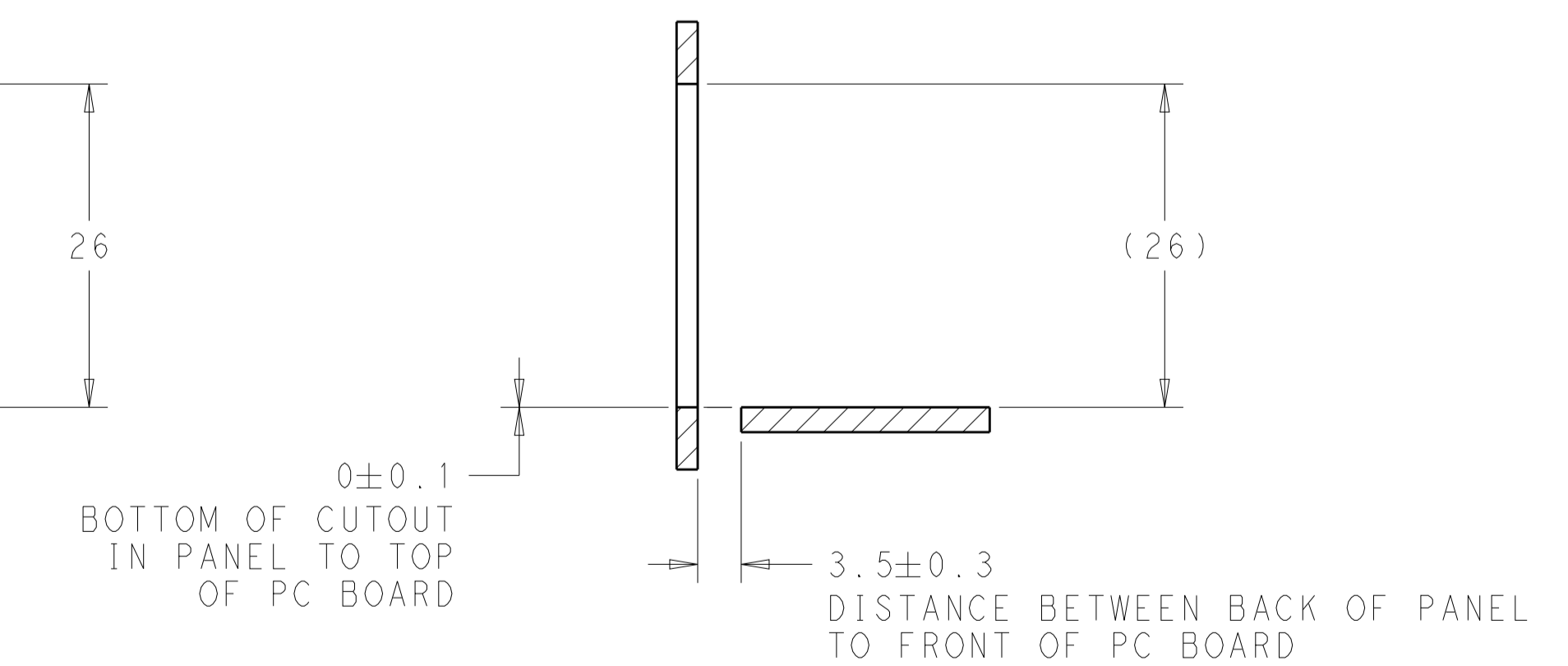

SECTION U-U
SCALE 2:1

| | | | | |
|---|--|--|-------------------------------------|---|
| THIS DRAWING IS A CONTROLLED DOCUMENT. DIMENSIONING AND TOLERANCING PER ASME Y14.5M-2009. | | OWN: C. VALENTINE CHK: J. PETERSON APVD: J. PETERSON | 08OCT2010 08OCT2010 08OCT2010 | TE Connectivity NAME: CAGE AND PT CONNECTOR ASSEMBLY, WITH EMI SPRINGS, PRESS FIT, 2X8, STACKED SFP+ |
| DIMENSIONS: mm | TOLERANCES UNLESS OTHERWISE SPECIFIED: | PRODUCT SPEC: 108-2331 | APPLICATION SPEC: 114-13219 | |
| MATERIAL: | FINISH: | WEIGHT: | CAGE CODE: 114-13219 | DRAWING NO: 2149490 |
| CUSTOMER DRAWING | | SCALE: 3:1 | SHEET: 4 OF 4 | REV: B1 |