

Power Splitter/Combiner

ZN3PD-622W-S+

3 Way-0° 50Ω 1800 to 6200 MHz



CASE STYLE: UU181

Connectors Model

SMA ZN3PD-622W-S+

+RoHS Compliant

The +Suffix identifies RoHS Compliance. See our web site for RoHS Compliance methodologies and qualifications

Maximum Ratings

Operating Temperature	-55°C to 100°C
Storage Temperature	-55°C to 100°C
Power Input (as a splitter)	10W max.
Internal Dissipation	0.6W max.
DC Current	750 mA (250 mA for each port)

Permanent damage may occur if any of these limits are exceeded.

Coaxial Connections

SUM PORT	S
PORT 1	1
PORT 2	2
PORT 3	3

Outline Drawing

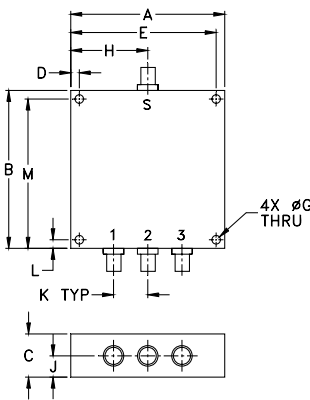

Outline Dimensions (inch/mm)

A	B	C	D	E	F	G
2.25	2.30	.63	.125	2.125	—	.125
57.15	58.42	16.00	3.18	53.98	—	3.18
H	J	K	L	M	wt	
1.13	.31	.500	.125	2.175	grams	
28.70	7.87	12.70	3.18	55.25	94	

Electrical Schematic

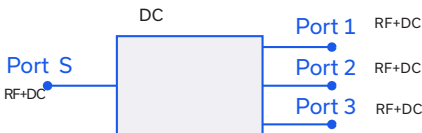

Features

- wideband, 1800 to 6200 MHz
- low insertion loss, 0.9 dB typ.
- low phase unbalance, 3.0 deg. typ.
- good isolation, 22 dB typ.
- DC Pass from sum port to all output ports

Applications

- PCS/UMTS
- LTE
- WIMAX
- WiFi
- bluetooth

Electrical Specifications at 25°C

Parameter	Frequency (MHz)	Min.	Typ.	Max.	Unit
Frequency Range		1800		6200	MHz
Insertion Loss Above 4.8 dB	1800-6200	—	1.0	1.5	
	2300-6000	—	0.8	1.2	dB
Isolation	1800-6200	15	20	—	dB
	2300-6000	16	22	—	
Phase Unbalance	1800-6000	—	3	7	Degree
Amplitude Unbalance	1800-6200	—	0.6	0.9	dB
VSWR (Port S)	1800-6200	—	1.4	—	:1
VSWR (Port 1-3)	1800-6200	—	1.3	—	:1

Typical Performance Data

Freq. (MHz)	Total Loss ¹ (dB)			Amp. Unbal. (dB)	Isolation (dB)			Phase Unbal. (deg.)	VSWR S	VSWR 1	VSWR 2	VSWR 3
	S-1	S-2	S-3		1-2	1-3	2-3					
1800.00	5.33	4.81	5.30	0.52	33.54	17.78	33.76	1.83	1.25	1.28	1.14	1.26
2000.00	5.49	4.95	5.46	0.53	26.23	19.07	26.02	1.69	1.40	1.30	1.11	1.28
2500.00	5.45	4.93	5.42	0.52	24.56	22.37	23.81	1.15	1.40	1.14	1.07	1.13
3000.00	5.34	4.88	5.29	0.47	31.30	26.23	30.21	1.46	1.11	1.19	1.22	1.18
3500.00	5.46	5.05	5.42	0.42	23.57	28.62	23.39	1.58	1.38	1.37	1.32	1.36
4000.00	5.47	5.06	5.43	0.41	22.50	26.29	21.91	2.00	1.22	1.19	1.22	1.19
4500.00	5.63	5.21	5.56	0.42	30.99	24.51	29.78	2.30	1.33	1.12	1.34	1.12
5000.00	5.58	5.22	5.50	0.36	22.65	24.85	23.33	2.60	1.35	1.16	1.19	1.15
5500.00	5.63	5.33	5.53	0.30	18.93	25.43	18.54	2.79	1.39	1.11	1.11	1.10
6000.00	5.71	5.38	5.62	0.33	21.34	20.61	19.85	3.21	1.27	1.30	1.18	1.29
6200.00	5.81	5.42	5.73	0.39	21.53	18.07	20.13	3.51	1.30	1.40	1.09	1.42

1. Total Loss = Insertion Loss + 4.8 dB splitter loss.

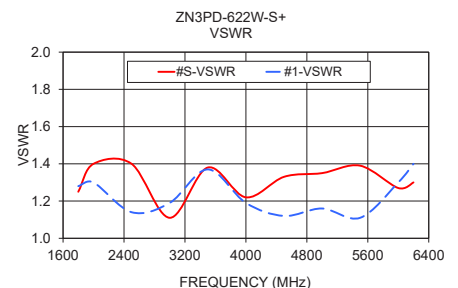
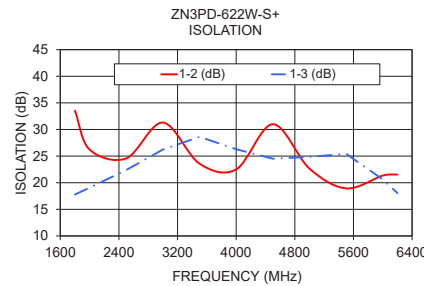
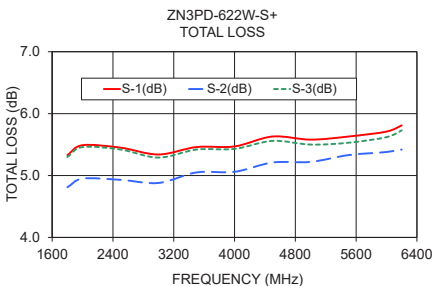

Notes

- Performance and quality attributes and conditions not expressly stated in this specification document are intended to be excluded and do not form a part of this specification document.
- Electrical specifications and performance data contained in this specification document are based on Mini-Circuit's applicable established test performance criteria and measurement instructions.
- The parts covered by this specification document are subject to Mini-Circuits standard limited warranty and terms and conditions (collectively, "Standard Terms"); Purchasers of this part are entitled to the rights and benefits contained therein. For a full statement of the Standard Terms and the exclusive rights and remedies thereunder, please visit Mini-Circuits' website at www.minicircuits.com/WCLStore/terms.jsp

