

SECTION A-A

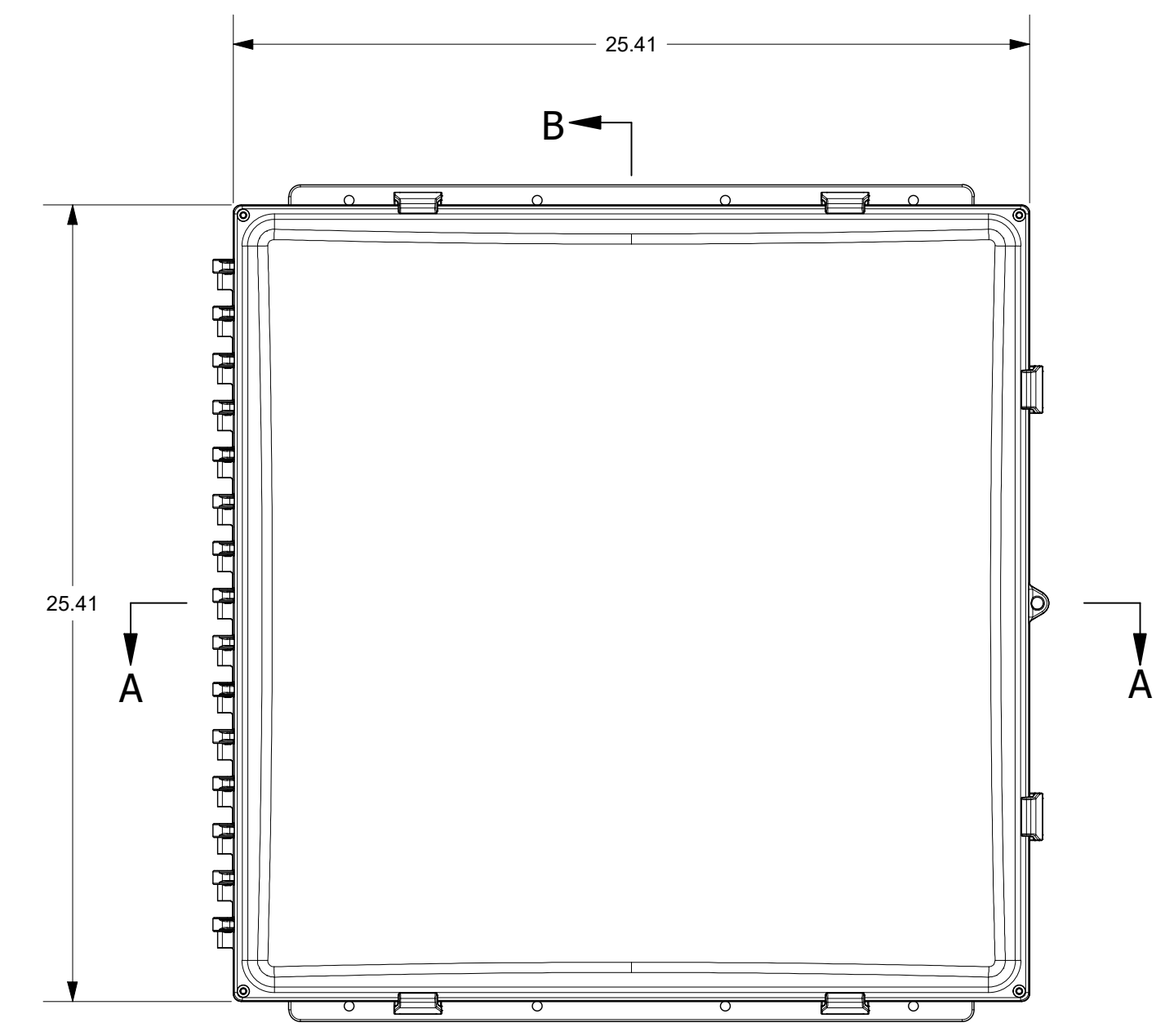

SECTION B-B

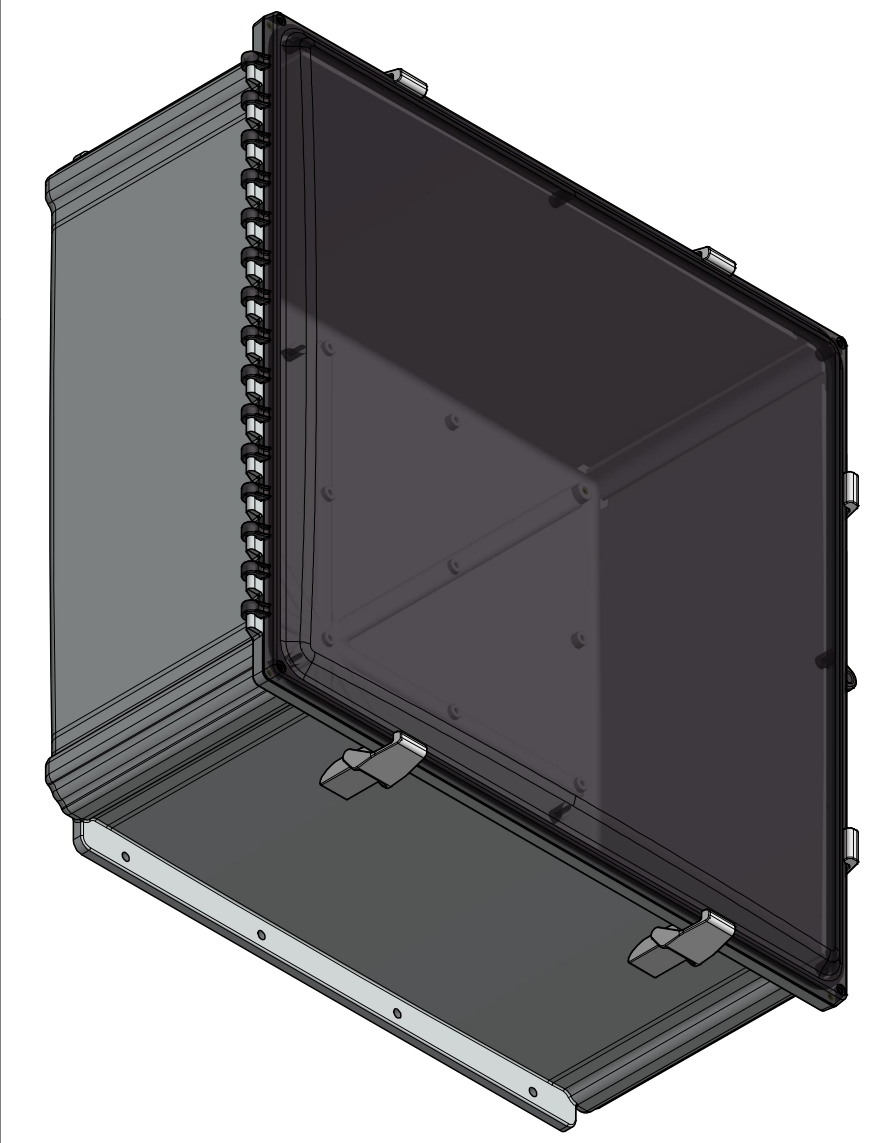
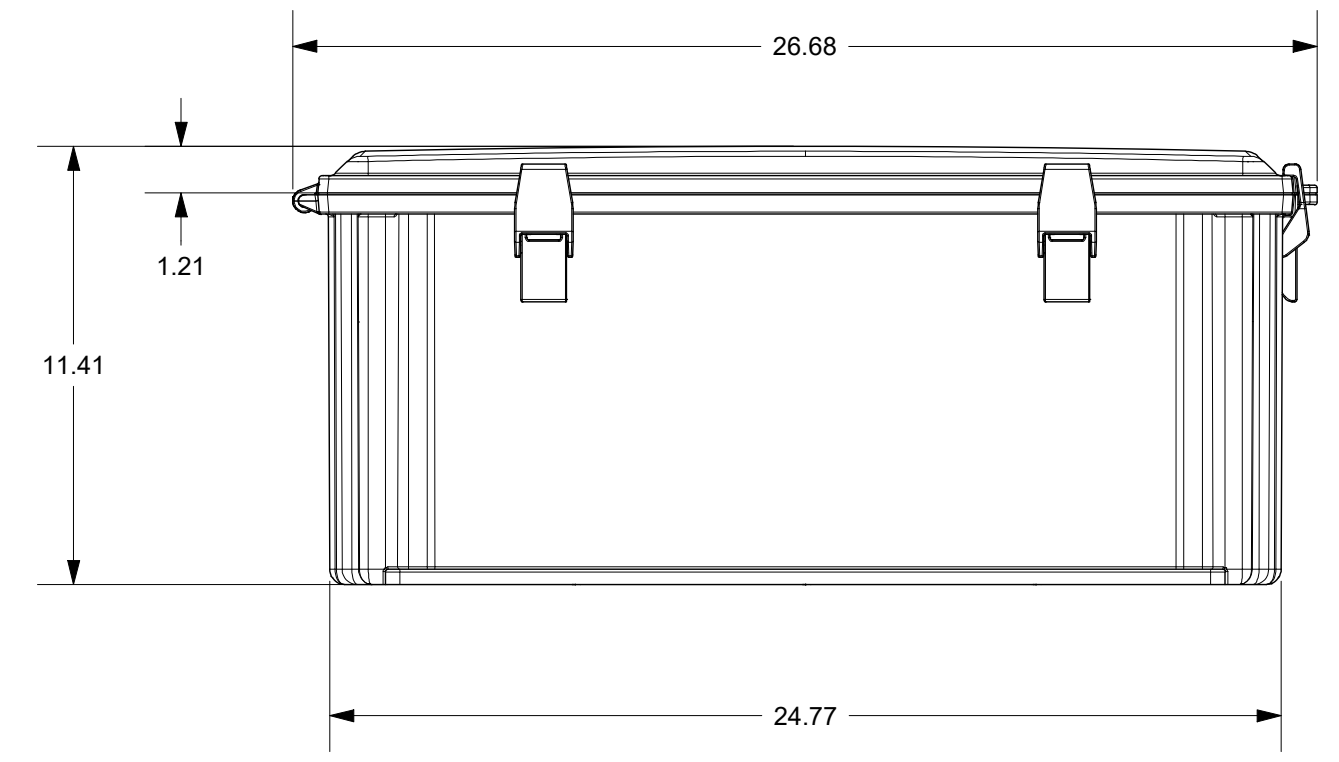
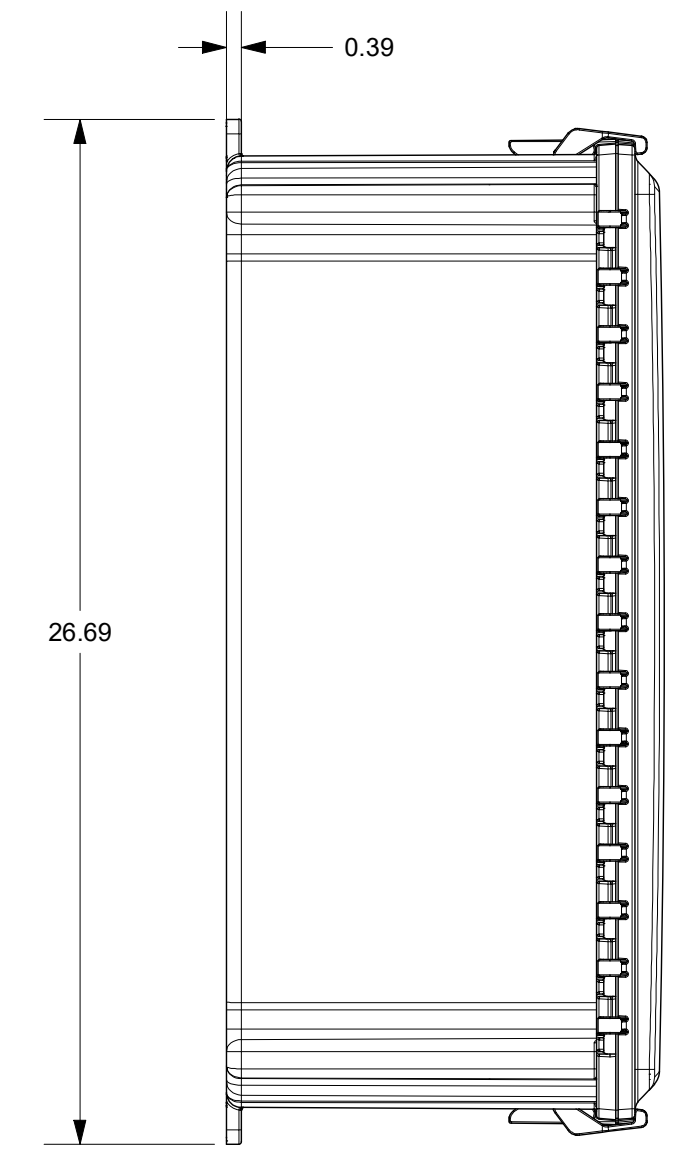
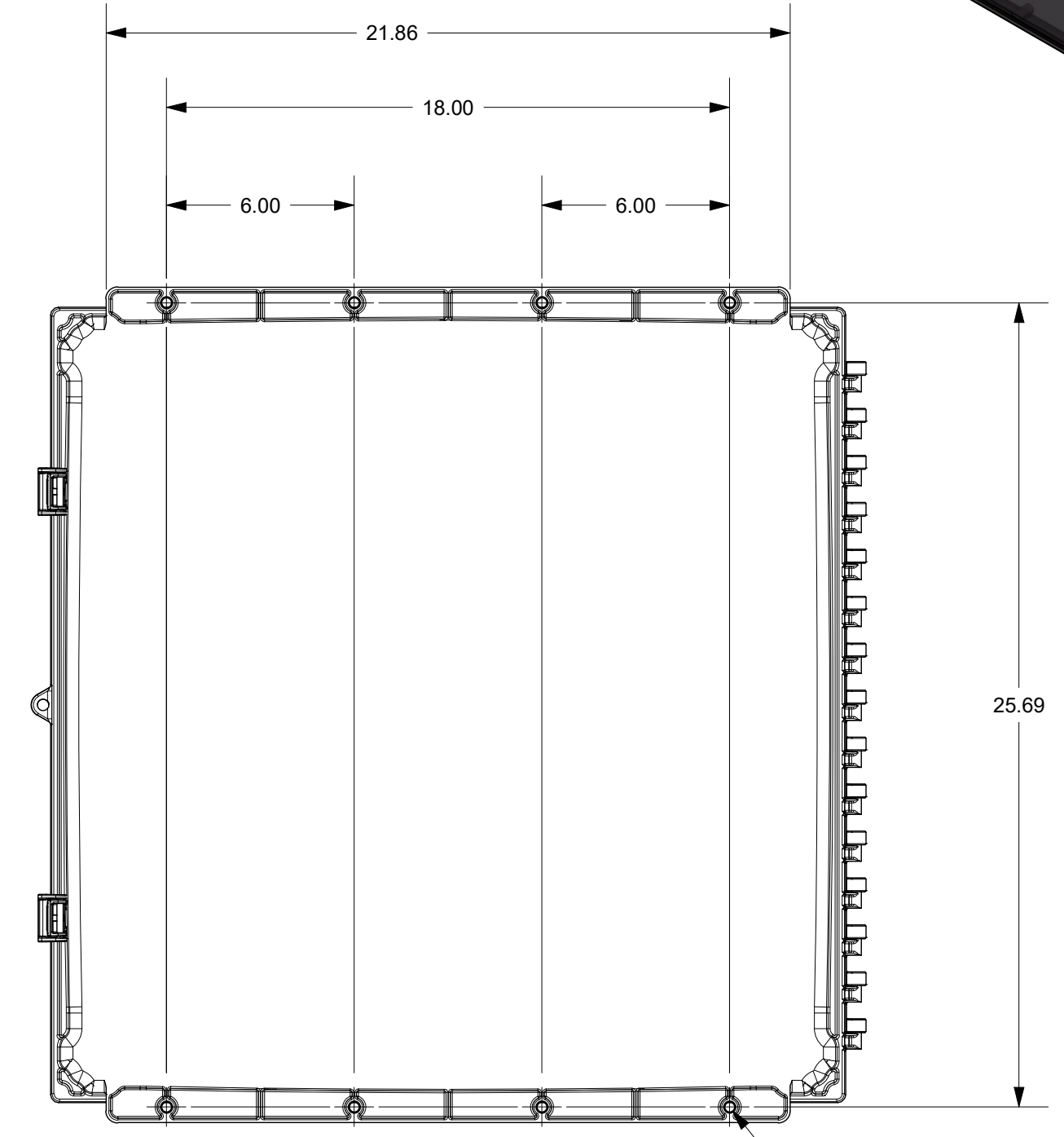

THIS DRAWING IS THE SOLE AND EXCLUSIVE PROPERTY OF ROBROY ENCLOSURES. NO PART OF THIS DRAWING MAY BE REPRODUCED, DISTRIBUTED, OR PUBLICALLY DISPLAYED IN ANY FORM OR BY ANY MEANS WITHOUT THE EXPRESS WRITTEN PERMISSION OF ROBROY ENCLOSURES. ALL RIGHTS RESERVED. UNDER THE COPYRIGHT LAWS. COPYRIGHT © 2016 ROBROY ENCLOSURES.

- SPECIAL REQUIREMENTS**
- ASSEMBLY:**
- (1) ACCESSORY KIT (WPPCACKKITNOFT) SHALL BE PACKAGED LOOSELY INSIDE ENCLOSURE
 - (1) STYROFOAM SHEET SHALL BE PLACED ON TOP OF COVER INSIDE CARTON
- HARDWARE INCLUDED:**
- (4) #10-32 x 5/8 PAN HEAD PHILLIPS MACHINE SCREW (RMSC1032X5/8SS)
 - (4) #10-32 x 3/8 PAN HEAD SCREW (RMSC1032X3/8ZN)
 - (4) #10 WASHER (RMWAS10ZN)

NEMA 250: TYPE 1, 3R, 4, 4X, 12
IEC 60529: IP66
COLOR: N/A
COLOR STANDARD: PANTONE 7541 C

STANDARD P/N: AH242410C
CUSTOMER DWG:

ALL DIMENSIONS ARE IN INCHES UNLESS OTHERWISE SPECIFIED
TOLERANCES UNLESS SPECIFIED .XX ± 0.03 .XXX ± 0.010

REV	DESCRIPTION	DATE	ENG
-	-	-	-
-	-	-	-
-	-	-	-
-	-	-	-
-	-	-	-
-	-	-	-

DRAWN BY: AJC		DATE: 11/23/16	CUSTOMER:	DWG: AH242410C
SCALE: DO NOT SCALE	DESCRIPTION: STANDARD ENCLOSURE	PART NUMBER: ATAH242410C		

