

符合"DLK环境管理物质技术标准"

符合USB3.0协会规范标准"

工程变更通知单 ECN(DCN) NO.	版本 REV	日期 DATE	说明 DESCRIPTION	变更 CHANGE	核准 APPRO.
KSECN20032	A	20200724	NEW RELEASE	—	—

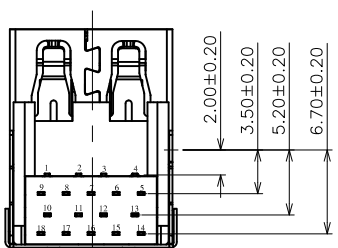
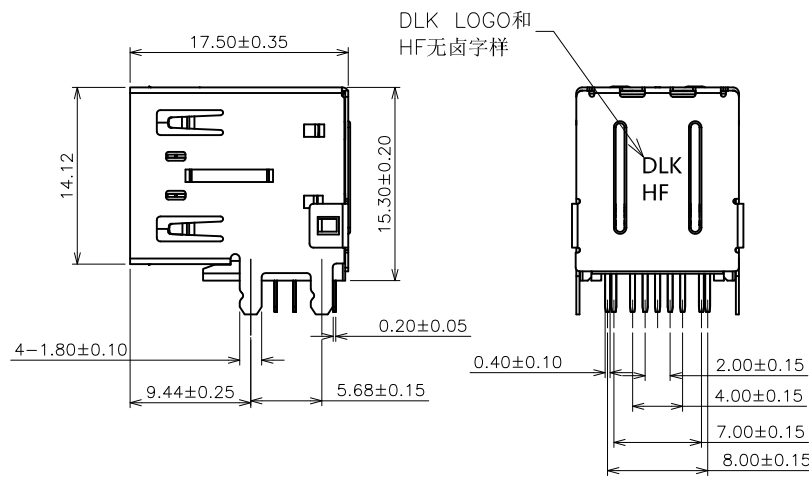
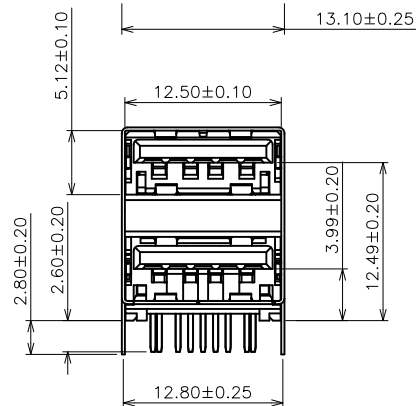
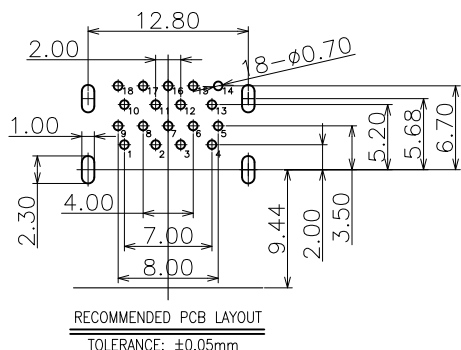
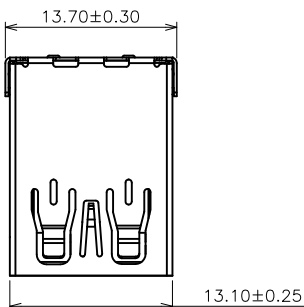

NOTE:

- MATERIAL:
  - Housing: LCP UL94v-0, color: Blue
  - Contact: Copper alloy
  - Shell: Stainless steel
- PLATING:
  - Contact: 1u" Au plated on contact Area,50u" Min. Matte Tin plated on solder tail,50u" Min. Nickel underplated
  - Shell: Nickel plated overall
- MECHANICAL:
  - Mating force:3.57kgf Max.
  - Unmating force:1.02kgf Min.
  - Durability:1500 cycles Min.
- ELECTRICAL:
  - Current Rating:1.5A
  - Voltage Rating:36V
  - Dielectric strength:500V AC FOR 1 minute
  - Insulation Resistance:1000MΩ Min.
  - Contact Resistance:30mΩ Max
- Operating Temperature:-55°c to +85°c
- PACKING: Tray

NO.	ITEM	Q'TY	DESCRIPTION	FINISH
5	MIDDLE SHELL	1	Stainless steel	Ni PLATED
4	COVER	1	LCP	UL94V-0
3	CONTACT	18	Copper alloy	Au PLATED
2	SHELL	1	Stainless steel	Ni PLATED
1	HOUSING	1	LCP	UL94V-0

GENERAL TOLERANCE UNLESS OTHERWISE NOTED	
Angle	±5°
X.	±0.35
.X	±0.25
.XX	±0.15
.XXX	±0.10

**德力康电子科技有限公司**  
DLK DELIKANG ELECTRONICS TECHNOLOGY CO.,LTD

C 名称: USB 3.0 AF DIP 双层 90° DIP  
档案名称: C-U3A20-0W-HF 料号: 22018L012W1  
FILE NAME: PART NO:

DRAWING: 王永辉 CHECKED: APPROVED: 严成旺

UNIT: mm SCALE: 1:1 SHEET: 1 of 1