

符合"DLK环境管理物质技术标准"

符合USB3.0协会规范标准"

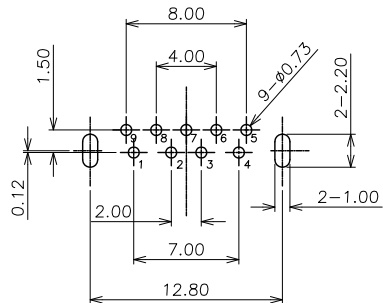

RECOMMENDED PCB LAYOUT
TOLERANCE: ±0.05mm

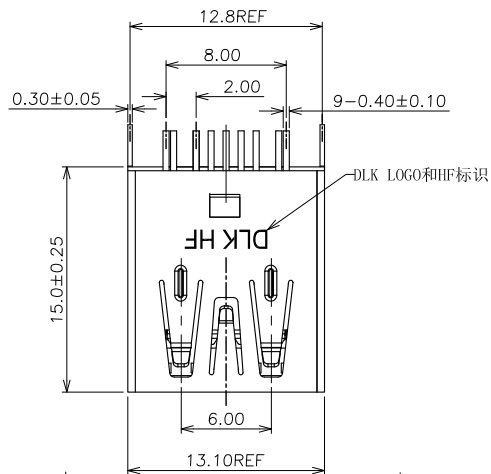
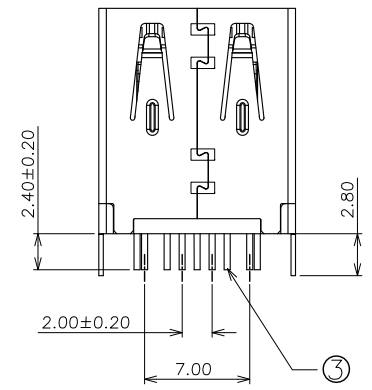
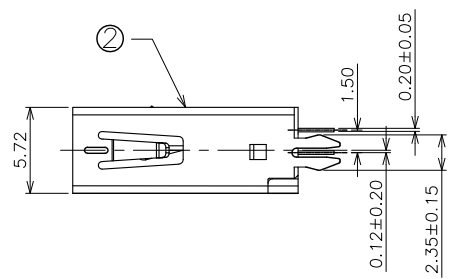
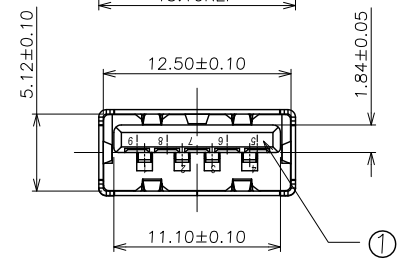

NOTE:

1. MATERIAL:
 - 1.1 Housing: PA9T HF UL94v-0, color: Yellow
 - 1.2 Contact: Copper Alloy
 - 1.3 Shell: Copper Alloy
2. PLATING:
 - 2.1 Contact: 30u" Au plated on contact Area, 50u" Min. Matte Tin plated on solder tail, 50u" Min. Nickel underplated
 - 2.2 Shell: Nickel plated overall
3. MECHANICAL:
 - 3.1 Mating force: 3.57kgf Max.
 - 3.2 Unmating force: 1.02kgf Min.
 - 3.3 Durability: 1500 cycles Min.
4. ELECTRICAL:
 - 4.1 Current Rating: 1.5A
 - 4.2 Voltage Rating: 36V
 - 4.3 Dielectric strength: 500V AC FOR 1 minute
 - 4.4 Insulation Resistance: 1000MΩ Min.
 - 4.5 Contact Resistance: 30mΩ Max
5. Operating Temperature: -55°C to +85°C
6. PACKING: Tray

3	CONTACT	9	Copper Alloy	Au PLATED
2	SHELL	1	Copper Alloy	Ni PLATED
1	HOUSING	1	PA9T HF	UL94V-0 BLACK
NO.	ITEM	Q'TY	DESCRIPTION	FINISH

工程变更通知单 ECN(DCN) NO.	版本 REV	日期 DATE	说明 DESCRIPTION	变更 CHANGE	核准 APPRO.
KSECN21012	A	20210128	NEW RELEASE	—	—
KSECN21070	B	20211231	修改侧边弹片结构	覃智森	吴豪

德力康电子科技有限公司
 DLK DELIKANG ELECTRONICS TECHNOLOGY CO.,LTD

GENERAL TOLERANCE UNLESS OTHERWISE NOTED		C 名称 TITLE: USB 3.0 AF 180D 14.9H DIP	
Angle	±5°	档案名称 FILE NAME: C-U3A27-02-HF	
X.	±0.35	料号 PART NO:	22709Y05201
.X	±0.25	DRAWING	蒋召
.XX	±0.15	CHECKED	—
.XXX	±0.10	APPROVED	覃智森
A4		UNIT:	mm
		SCALE	1:1
		SHEET:	1 of 1