

符合"DLK环境管理物质技术标准"

符合USB3.0协会规范标准"

工程变更通知单 ECN(DCN) NO.	版本 REV	日期 DATE	说明 DESCRIPTION	变更 CHANGE	核准 APPRO.
_____	X0	20220729	NEW RELEASE	—	—
KSECN23005	A	20231107	增加剖面视图	蒋召	段国强

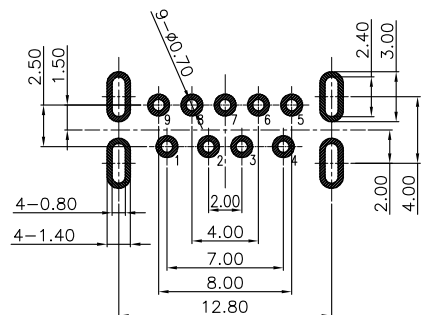
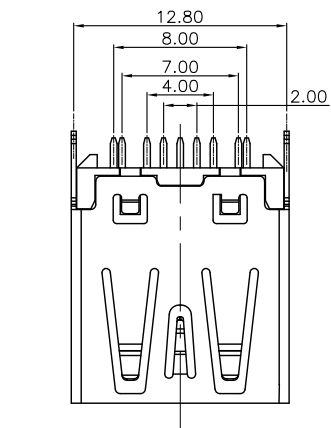

RECOMMENDED PCB LAYOUT  
TOLERANCE: ±0.05mm

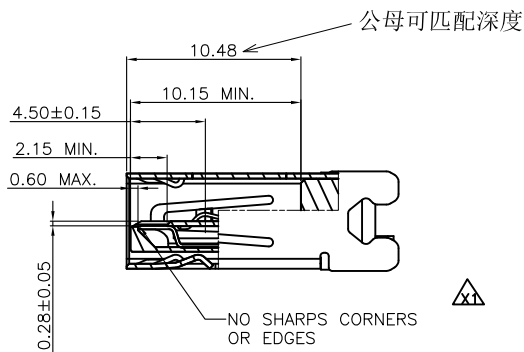
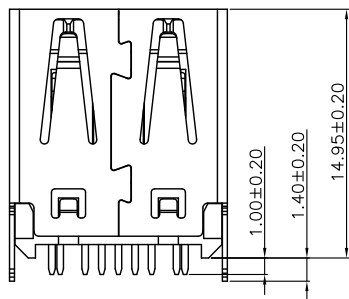
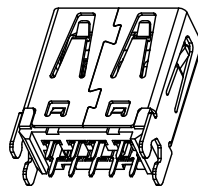
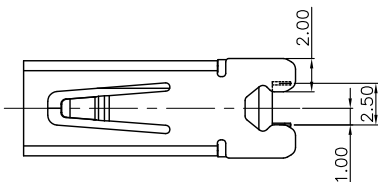
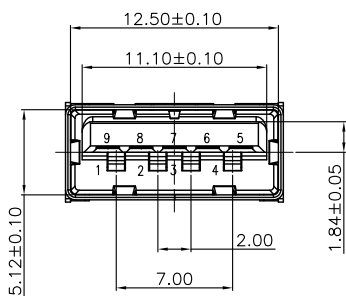

NOTE:

1. MATERIAL.

1.1 Housing: PA9T HF/LCP UL94v-0, color: Blue

1.2 Contact: Copper Alloy

1.3 Shell: Stainless steel

2. PLATING:

2.1 Contact: 1u" Au plated on contact Area,50u" Min.

Matte Tin plated on solder tail,50u" Min. Nickel underplated

2.2 Shell: Nickel plated overall

3. MECHANICAL:

3.1 Mating force:3.57kgf Max.

3.2 Unmating force:1.02kgf Min.

3.3 Durability:1500 cycles Min.

4 ELECTRICAL:

4.1 Current Rating:1.5A

4.2 Voltage Rating:36V

4.3 Dielectric strength:500V AC FOR 1 minute

4.4 Insulation Resistance:1000MΩ Min.

4.5 Contact Resistance:30mΩ Max

5. Operating Temperature:-55°c to +85°c

6. PACKING: Tape & Reel

4	CAP	1	LCP BLACK	UL94V-0
3	CONTACT	9	Copper Alloy	Au PLATED
2	SHELL	1	Stainless steel	Ni PLATED
1	HOUSING	1	PA9T HF	UL94V-0 BLUE(300C)
NO.	ITEM	Q'TY	DESCRIPTION	FINISH

GENERAL TOLERANCE  
UNLESS OTHERWISE NOTED



德力康电子科技有限公司  
DLK DELIKANG ELECTRONICS TECHNOLOGY CO.,LTD

Angle	±5°
X.	±0.35
.X	±0.25
.XX	±0.15
.XXX	±0.10

C 名称 TITLE:	USB 3.0 A/F V/T 14.95H SMT type STD.			
档案名称 FILE NAME:	C-U3A27-0P-HF	料号 PART NO:	22709L012P1	
DRAWING	蒋召	CHECKED	覃智森	APPROVED 段国强
UNIT:	mm	SCALE	1:1	SHEET: 1 of 1