

符合"DLK环境管理物质技术标准"

符合USB3.0协会规范标准"

工程变更通知单 ECN(DCN) NO.	版本 REV	日期 DATE	说明 DESCRIPTION	变更 CHANGE	核准 APPRO.
KSECN21018	A	20210302	NEW RELEASE	—	—
KSECN22037	B	20220907	修改鱼叉脚尺寸	蒋召	覃智森

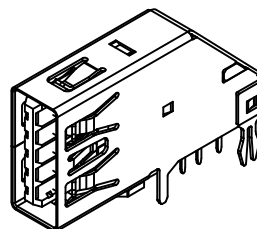
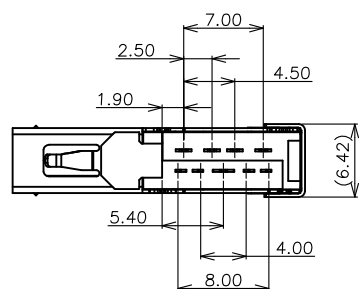
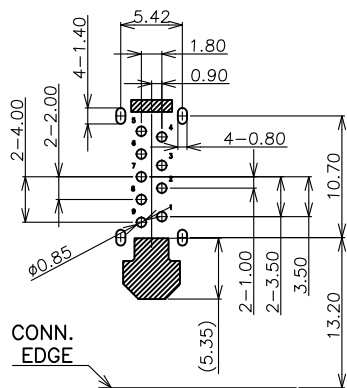
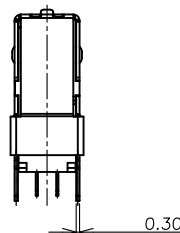
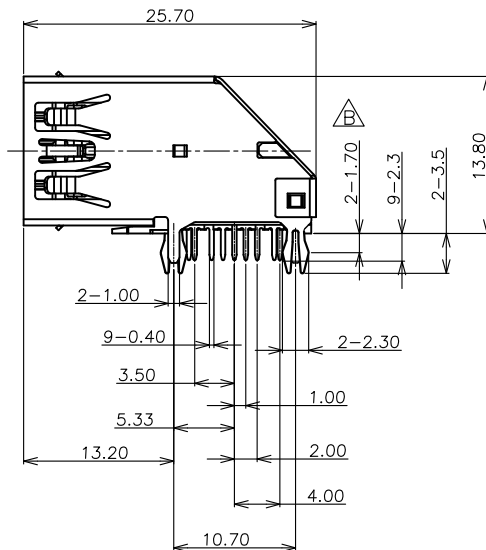
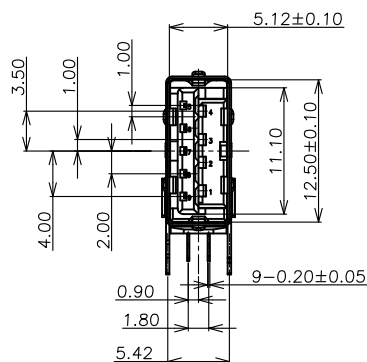
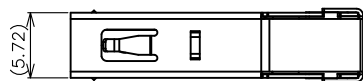

NOTE:

- MATERIAL:
 - Housing: LCP UL94v-0, color: Blue
 - Contact: Copper alloy
 - Shell: Stainless steel
- PLATING:
 - Contact: 1u" Au plated on contact Area,50u" Min. Matte Tin plated on solder tail,50u" Min. Nickel underplated
 - Shell: Nickel plated overall
- MECHANICAL:
 - Mating force:3.57kgf Max.
 - Unmating force:1.02kgf Min.
 - Durability:1500 cycles Min.
- ELECTRICAL:
 - Current Rating:1.5A
 - Voltage Rating:36V
 - Dielectric strength:500V AC FOR 1 minute
 - Insulation Resistance:1000MΩ Min.
 - Contact Resistance:30mΩ Max
- Operating Temperature:-55°c to +85°c
- PACKING: Tray

RECOMMENDED PCB LAYOUT
PCB T=1.60MM TOL: ±0.05

STAND OFF AREA(PLASTIC)

GENERAL TOLERANCE
UNLESS OTHERWISE NOTED

Angle	±5°
X.	±0.35
.X	±0.25
.XX	±0.15
.XXX	±0.10



德力康电子科技有限公司

DLK DELIKANG ELECTRONICS TECHNOLOGY CO.,LTD

C 名称 TITLE:	USB 3.0 AF DIP TYPE RVS 侧插			
档案名称 FILE NAME:	C-U3A26-00-04	料号 PART NO:	22609L01241	
DRAWING	蒋召	CHECKED	—	APPROVED 覃智森
UNIT:	mm	SCALE	1:1	SHEET: 1 of 1

NO.	ITEM	Q'TY	DESCRIPTION	FINISH
3	CONTACT	9	Copper alloy	Au PLATED
2	SHELL	1	Stainless steel	Ni PLATED
1	HOUSING	1	LCP	UL94V-0