

符合"DLK环境管理物质技术标准"

符合USB3.0协会规范标准"

工程变更通知单 ECN(DCN) NO.	版本 REV	日期 DATE	说明 DESCRIPTION	变更 CHANGE	核准 APPRO.
KSECN18003	A	20180205	NEW RELEASE	—	—

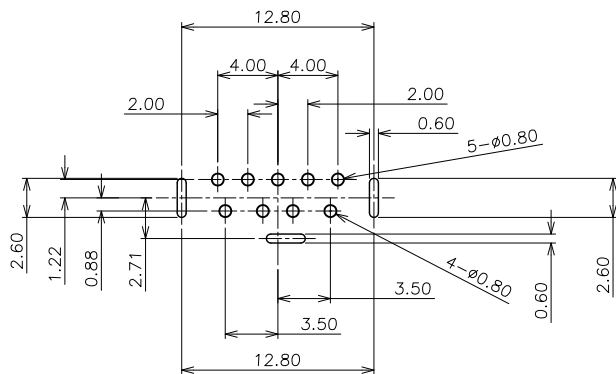
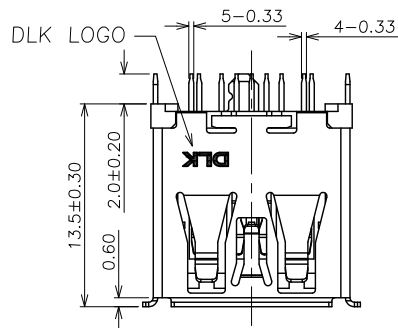

RECOMMENDED PCB LAYOUT
TOLERANCE: ±0.05mm

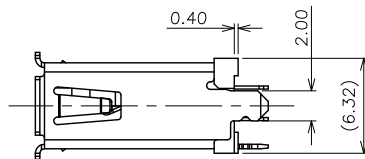
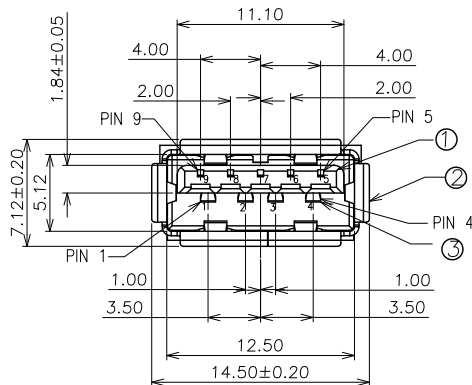

DETAIL "A"

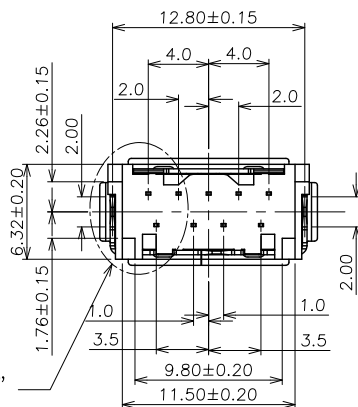

NOTE:

- MATERIAL:
 - Housing: PA9T UL94v-0, color: Blue
 - Contact: Copper Alloy
 - Shell: Stainless steel
- PLATING:
 - Contact: 30u" Au plated on contact Area,50u" Min. Matte Tin plated on solder tail,50u" Min. Nickel underplated
 - Shell: Nickel plated overall
- MECHANICAL:
 - Mating force:3.57kgf Max.
 - Unmating force:1.02kgf Min.
 - Durability:1500 cycles Min.
- ELECTRICAL:
 - Current Rating:1.5A
 - Voltage Rating:36V
 - Dielectric strength:500V AC FOR 1 minute
 - Insulation Resistance:1000MΩ Min.
 - Contact Resistance:30mΩ Max
- Operating Temperature:-55°c to +85°c
- PACKING: Tray

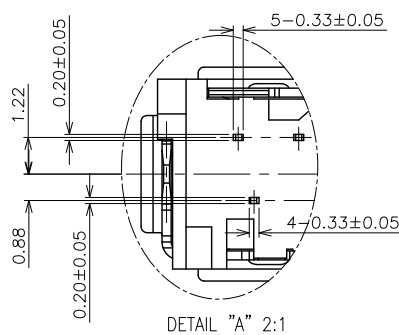
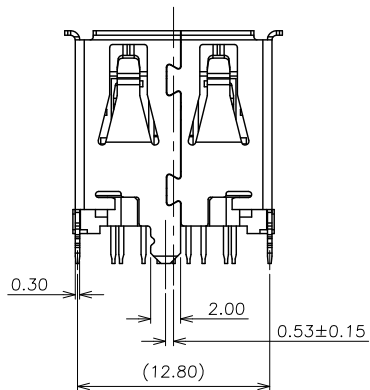

DETAIL "A" 2:1

德力康电子科技有限公司
DLK DELIKANG ELECTRONICS TECHNOLOGY CO.,LTD

GENERAL TOLERANCE
UNLESS OTHERWISE NOTED

Angle	±5°
.X	±0.35
.X	±0.25
.XX	±0.15
.XXX	±0.10

C 名称 TITLE:	USB 3.0 AF 180° 13.5H DIP			
档案名称 FILE NAME:	C-U3A27-00-05	料号 PART NO:	22709L052P0	
DRAWING	王永辉	CHECKED	—	APPROVED 严成旺
UNIT:	mm	SCALE	1:1	SHEET: 1 of 1

3	CONTACT	9	Copper Alloy	Au PLATED
2	SHELL	1	Stainless steel	Ni PLATED
1	HOUSING	1	PA9T	UL94V-0
NO.	ITEM	Q'TY	DESCRIPTION	FINISH