

符合"DLK环境管理物质技术标准"

符合USB3.0协会规范标准"

工程变更通知单 ECN(DCN) NO.	版本 REV	日期 DATE	说明 DESCRIPTION	变更 CHANGE	核准 APPRO.
KSECN21068	A	20220121	NEW RELEASE	—	—

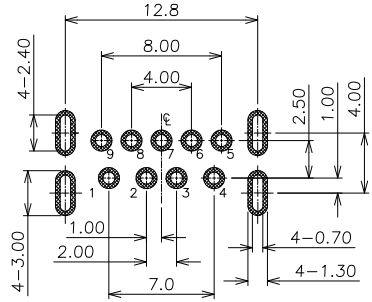
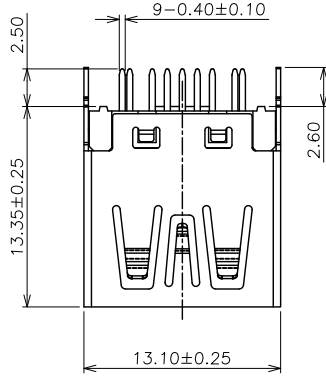

RECOMMENDED PCB LAYOUT(TOP VIEW)
GENERAL TOLERANCES:±0.05(T=1.6/1.2)

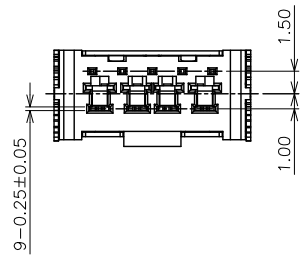
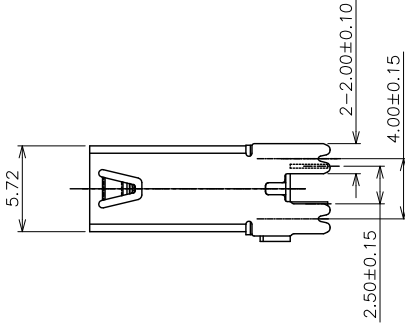
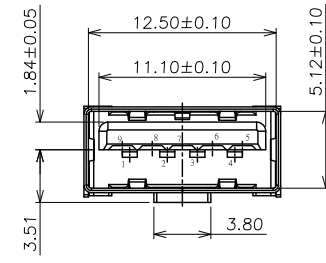

NOTE:
 1. MATERIAL:
 1.1 Housing: LCP UL94v-0, color: Black
 1.2 Contact: Phosphor bronze
 1.3 Shell: Stainless steel
 2. PLATING:
 2.1 Contact: 1u" Au plated on contact Area,50u" Min. Matte Tin plated on solder tail,50u" Min. Nickel underplated
 2.2 Shell: Nickel plated overall
 3. MECHANICAL:
 3.1 Mating force:3.57kgf Max.
 3.2 Unmating force:1.02kgf Min.
 3.3 Durability:1500 cycles Min.
 4 ELECTRICAL:
 4.1 Current Rating:1.5A
 4.2 Voltage Rating:36V
 4.3 Dielectric strength:500V AC FOR 1 minute
 4.4 Insulation Resistance:1000MΩ Min.
 4.5 Contact Resistance:30mΩ Max
 5. Operating Temperature:-55°c to +85°c
 6. PACKING: Reel

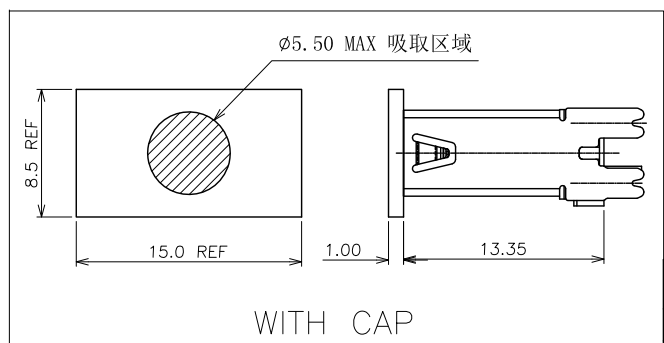
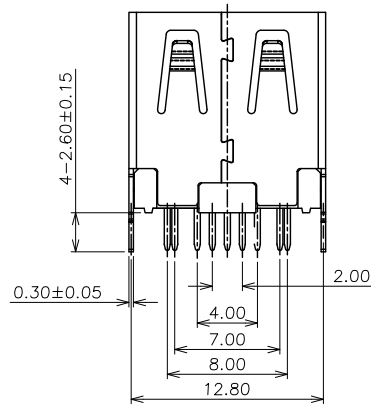

德力康电子科技有限公司
 DLK DELIKANG ELECTRONICS TECHNOLOGY CO.,LTD

GENERAL TOLERANCE UNLESS OTHERWISE NOTED	
Angle	±5°
.X	±0.35
.X	±0.25
.XX	±0.15
.XXX	±0.10
A4	

C	名称 TITLE:	USB 3.0 AF 180° 13.35H DIP			
	档案名称 FILE NAME:	C-U3A27-00-2L	料号 PART NO.:	22709B012L1	
	DRAWING	覃智森	CHECKED	APPROVED	吴豪
	UNIT:	mm	SCALE	1:1	SHEET: 1 of 1

3	CONTACT	9	Phosphor bronze	Au PLATED
2	SHELL	1	Stainless steel	Ni PLATED
1	HOUSING	1	LCP	UL94V-0
NO.	ITEM	Q'TY	DESCRIPTION	FINISH