

TankSensor Series

High Performance, IP67 Weather Resistant, Ultrasonic Range Finder

MB7850, MB7851, MB7853, MB7854³

The TankSensor series provides users with robust range information in air and is recommended for liquid level measurement usage.

These sensors feature a maximum range of 5000-mm or 16500-mm, a minimum reported range of 50-mm or 300-mm, the ability to detect presence of liquids down to 0-mm, and can operate on supply voltages as low as 2.5V and as high as 40V (Depending on model). Sensors available with centimeter or millimeter resolution. high-power acoustic output along with real-time auto sensitivity adjustment allow these sensors to be extremely robust to supply voltage sag, acoustic noise, and electrical noise. Output options include Analog Voltage, TTL or RS232 Serial Data, and Analog Voltage Envelope. The sensor is housed in a robust ABS housing, designed to meet the IP67 water intrusion standard. The top thread is a 3/4"-14 NPS, with the end of the horn being a 2" NPS thread.



Features

- Real-time auto sensitivity adjustment and noise rejection
- High acoustic power output
- Precise narrow beam characteristics
- Liquid detection includes zero range
- Free run and triggered modes available
- Ultrasonic Frequency:
 - 25KHz (MB7853, MB7854)
 - 42KHz (MB7850, MB7851)

Power Consumption

- Wide supply voltage range:
 - 3V-5.5V (MB7850+MB7851)²
 - 2.5-5V (MB7853)²
 - 5.5V-40V (MB7854)²
- Average current draw as low as 1.6mA

Interface Options

- All interfaces are active simultaneously
- RS232/TTL Serial, 0 to Vcc, 9600 Baud, 81N (0-5V with regulator)
- Analog voltage output
- Real-time Analog Envelope

Ranging Performance

- High refresh rate:
 - 4.032Hz (MB7850)
 - 1.95Hz (MB7851)
 - 1.2Hz (MB7853, MB7854)
- Millimeter or Centimeter resolution available.
- MB7853 and MB7854 will range in 10-mm increments beyond 5000-mm and in roughly 20-mm increments closer than 500-mm.

Benefits

- Acoustic and electrical noise resistance
- Reliable and stable range data
- Robust, low cost IP67 standard sensor
- Very low power, excellent for battery based systems
- Sensor reports the range reading directly, frees up user processor
- Easy to install with standard electrical fittings
- Filtering allows very reliable operation in most environments

Applications and Uses

- Tank level measurement
- Environments with acoustic and electrical noise
- Liquid Distance Measuring
- Industrial sensor -40° C to +65° C ²

Summary of Models

P/N	Description
MB7850	5 Meters, Centimeter Resolution, 3-5.5V Operation
MB7851	5 Meters, Millimeter Resolution, 3-5.5V Operation
MB7853	16.5 Meters, Millimeter Resolution, 2.5-5V Operation
MB7854	16.5 Meters, Millimeter Resolution, 5.5-40V Operation with Regulator

Notes:

¹ Minimum distance is 50-mm (MB7850, MB7851) or 300-mm (MB7853, MB7854)

² Please reference page 8 for minimum operating voltage verses temperature information

³ Please reference page 17 for part number key

⁴ The MB7850 and MB7851 can attempt to find targets out to 6.5 Meters, but operation beyond 5 Meters is not guaranteed.

Close Range Operation

Applications requiring 100% reading-to-reading reliability should not use a TankSensor at a distance closer than minimum distance¹. MaxBotix[®] Inc. does not guarantee operational reliability for objects closer than the minimum reported distance. Because of ultrasonic physics, these sensors are unable to achieve 100% reliability at close distances.

Warning: Personal Safety Applications

We do not recommend or endorse this product be used as a component in any personal safety applications. This product is not designed, intended or authorized for such use. These sensors and controls do not include the self-checking redundant circuitry needed for such use. Such unauthorized use may create a failure of the MaxBotix[®] Inc. product which may result in personal injury or death. MaxBotix[®] Inc. will not be held liable for unauthorized use of this component.

About Ultrasonic Sensors

Our ultrasonic sensors are non-contact object detection and ranging sensors that detect objects within a defined area. These sensors are designed for use in air. Ultrasonic sensors are not affected by the color or other visual characteristics of the detected object. Ultrasonic sensors use high frequency sound to detect and localize objects in a variety of environments. Ultrasonic sensors measure the time of flight for sound that has been transmitted to and reflected back from nearby objects. Based upon the time of flight, the sensor then outputs a range reading.

TankSensor Interface Descriptions

Pin Out

Pin Number	Pin Name	Function	Standard Wire Color
1	RX	Serial receive	White
2	AE	Real time analog envelope output of the acoustic waveform	Orange
3	AV	Analog Voltage	Brown
4	FREERUN/ TRIGGER	Switch between Freerun operation and Triggered operation. Pull HIGH or let float for Freerun, Pull LOW to prevent ranging. Pull HIGH for atleast 20uS to command a single range reading.	Green
5	TX	Serial Transmit	Blue
6	V+	Power Supply	Red
7	GND	Ground—Return for the DC power supply. GND (& V+) must be ripple and noise free for best operation.	Black

Note: No pin should be exposed to voltages exceeding V+ or below GND at any time. If these conditions are encountered, the reliability and operation of the sensor could be effected. Additionally, for sensors with an included voltage regulator, no pin other than V+ should be exposed to voltages exceeding 5.0 Volts at any time.

Analog Envelope Output

This pin will output the raw analog waveform received by the sensor. Once per range reading, the transmit pulse will be visible on this pin as a large spike approaching Vcc, which will then be followed by the acoustic return signal.

Analog Voltage Output

The resolution of the Analog Voltage output on the TankSensor line is limited to 1024 discrete steps, yielding a scale factor of Vcc/1024 per cm for MB7850 and MB7851, and Vcc/1024 per 2cm for MB7853 and MB7854. The output is buffered and corresponds to the most recent range data.

For your convenience, the scale factors expressed in terms of millivolts per centimeter are shown in the table below. Please note that MB7853 and MB7854 report in 2 Centimeter resolution.

Sensor @ Voltage	Scale Factor
MB7850 @ 5.0V	4.88mV/cm
MB7851 @ 5.0V	4.88mV/cm
MB7853 @ 5.0V	2.44mV/cm
MB7854 @ 5.5-40V	2.44mV/cm

Sensor @ Voltage	Scale Factor
MB7850 @ 3.3V	3.22mV/cm
MB7851 @ 3.3V	3.22mV/cm
MB7853 @ 3.3V	1.61mV/cm

Serial Communications

All TankSensors operate with the following serial configuration: 9600 Baud, 8 data bits, no parity, one stop bit.

If Pin 2 is left floating or held high, the sensor will communicate with TTL serial data. If Pin 2 is pulled to ground, the sensor will communicate with RS232 serial data, except that it is at TTL voltage levels. 0-Vcc or 0-5V (MB7854) The status of Pin 2 is checked once on power up, about ~40mS after V+ is applied.

Although the voltages of 0V to Vcc are outside the RS232* standard, most RS232* devices have sufficient margin to read the 0V to Vcc serial data. If standard voltage level RS232* is desired, invert, and connect an RS232* converter such as a MAX232.

Standard Range Information

Part Number	Format	Description
MB7850	R### T###r	“R” followed 3 ASCII numerical digits representing the range in centimeters. This will be followed by a space, then “T” followed by 3 ASCII numerical digits representing the teach confidence. Concluding with a carriage return.
MB7851	R#### T###r	“R” followed 4 ASCII numerical digits representing the range in millimeters. This will be followed by a space, then “T” followed by 3 ASCII numerical digits representing the teach confidence. Concluding with a carriage return.
MB7853 MB7854	R##### T###r	“R” followed 5 ASCII numerical digits representing the range in millimeters. This will be followed by a space, then “T” followed by 3 ASCII numerical digits representing the teach confidence. Concluding with a carriage return.

If no target is detected the sensor will report 999 (MB7850) or 6500 (MB7851) or 16500 (MB7853, MB7854)

Advanced Range Information

Below is the description of outputs when advanced range information is turned on. The following values are reported in different units depending on the sensor. MB7850 reports in centimeters. MB7851 reports in increments of ~0.96cm.

MB7853 and MB7854 report in increments of ~1.93cm. Additionally, some of the values are output in millimeters as specified below.

Part Number	Format
MB7850	v### f### s### d### i### s### T### o###\r
MB7851	v### f### s### d### i### s### T### R##### m##### o###\r
MB7853 and MB7854	v##### f##### s##### d##### i##### s##### T### R##### m##### o##### k#####\r
Leading Character	Description
“v”	This value is the filtered expected range value for comparison testing.
“f”	This value is the first attempt range reading detected using the long range algorithm.
“s”	This value is the range of a second chance test if no target was found on first attempt.
“d”	This value is the range returned if the sensor believes the first range reading may have been a secondary reflection.
“i”	This value compares the reported first range reading and the short range reading.
“s”	This value is the short range reading value (taken using a separate ranging algorithm).
“T”	This value is the three digit teach confidence level for the training/calibration of the sensor.
“R”	This value is the final filtered range output in millimeters. This is equivalent to the “R” value in the standard output. (MB7851, MB7853, and MB7854 Only)
“m”	This value is the raw millimeter output with no reading-to-reading filtering applied. (MB7851, MB7853, and MB7854 Only)
“o”	This value is an index representing where the final target was found this range cycle.
“k”	This value is the current ambient temperature in hundredths of degrees kelvin. For example, and output of 29315 is 293.15 Kelvin. This output will report 29315 if temperature compensation is disabled. (MB7853 and MB7854 only)
Final Character	This value will be a carriage return.
Note: If a test is not ran, the range output will be 000 (MB7850 + MB7851) or 0000 (MB7853 + MB7854). If no target is found the range output will be 999 (MB7850 + MB7851) or 1440 (MB7853 + MB7854).	

Serial Commands

TankSensors are equipped with a robust series of serial commands which allow the user to customize the performance of the TankSensor. All available commands are listed below.

Commands must be sent in the 10mS following the final character of the reported range data. If a command is sent after 10mS the command will be ignored. The final character of the range data will be a carriage return (decimal 13 or hex 0xd). Below is the list of all available commands.

Command Character	Effect
“T” or “t”	<p align="center">Save New Calibration</p> <p>This command is recommended to be used to store information on what the empty tank looks like. This is used to improve the reliability of short range readings. This command should only be used in empty tanks or when there is no target within one meter (MB7850, MB7851) or two meters (MB7853, MB7854) of the sensor. One of the serial outputs is a teach confidence output value. If that number drops below 75%, we would recommend retraining the sensor when the tank is emptied. Teaching the sensor will bring this teach confidence output near 100%.</p>
“R” or “r”	<p align="center">Restore Factory Calibration</p> <p>If a bad teach value is sent to the sensor, and you need to restore a known value. This command restores the calibration values that were set in the factory.</p>
“M” or “m”	<p align="center">Set Max Range</p> <p>This command will expect to receive three (MB7850) or four (MB7851) or five (MB7853, MB7854) ASCII number characters to set the max range. It is recommended to set this to the height of the tank. This command is limited to 750mm - 6500mm (MB7850, MB7851) or 750 - 16500mm (MB7853, MB7854) . This setting is preserved through power cycles. Values outside of this range will be limited to this range. This command can be used regardless of fill status of the tank.</p>
“A” or “a”	<p align="center">Analog Envelope ON</p> <p>This command can be used to output advanced debug information from the sensor. This data contains an acoustic waveform. This information can be sent to MaxBotix for assistance in troubleshooting advanced problems.</p>
“a”	<p align="center">Analog Envelope OFF</p> <p>This command turns off the debug information. Power cycling the sensor also has the same effect.</p>
“D”	<p align="center">Advanced Range ON</p> <p>This command can be used to output advanced range information.</p>
“d”	<p align="center">Advanced Range OFF</p> <p>This command turns off advanced range information. Power cycling the sensor also has the same effect.</p>
“K”	<p align="center">Temperature Compensation ON</p> <p>This will turn on automatic temperature compensation. (MB7853 and MB7854 only) This is recommended to only be used in environments with a small temperature gradient across the range of the sensor. This setting is preserved through power cycles.</p>
“k”	<p align="center">Temperature Compensation OFF</p> <p>This command will turn off automatic temperature compensation. (MB7853 and MB7854 only) This setting is preserved through power cycles.</p>
“E” or “e”	<p align="center">Repeat Boot Data</p> <p>This command will cause the sensor to repeat the output of it’s boot data. This can be useful if checking the firmware version or part number after sensor powerup is desired.</p>
All other characters	All other characters are reserved.

A bootloader is available for this part upon request, please contact sensors@maxbotix.com.

TankSensor Operating Modes

Single Sensor Operation

The TankSensor is designed to operate in a single sensor environment. Free-run is the default mode of operation for all of the MaxBotix Inc. sensors. Below is a diagram on how to connect the sensor for serial communication.

Multiple Sensor Operation

When using multiple tank sensors in a single tank, there can be interference (cross-talk) from the other sensors, therefore each sensor should be isolated into their own tank, to avoid ranging interference. Below is a diagram on how to connect multiple sensors to one controller. **Testing is recommend to verify what method will work for your application.**

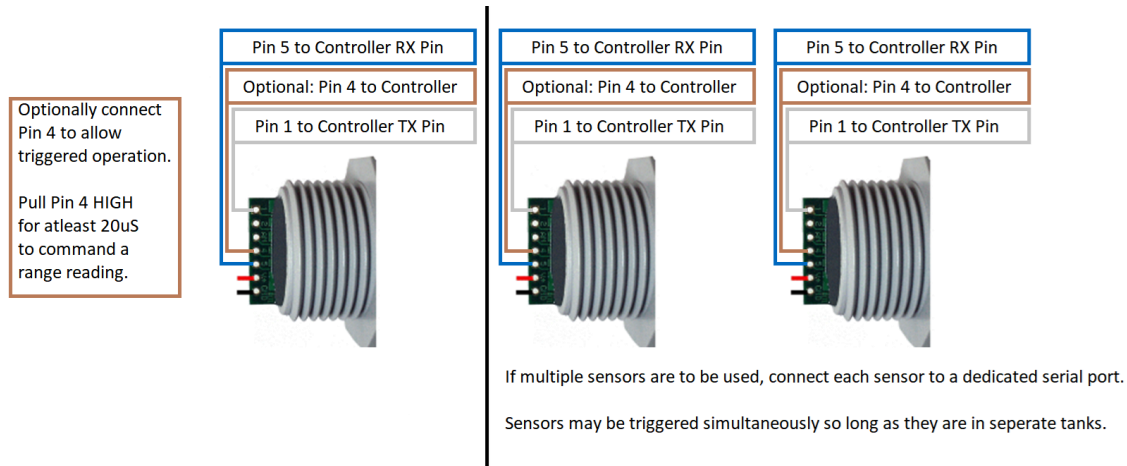

Freerun/Triggered Modes of Operation

If Pin-4 is left unconnected or held high, the sensor will continually measure the range. If Pin-4 is held low the sensor will stop ranging. Bring high 20uS or more to command a range reading.

TankSensor Performance Characteristics

Maximum Range

The MB7850 and MB7851 have a maximum range of 5000-mm. The MB7850 will report this in centimeters. The MB7851 will report this in millimeters. Both of these sensors will attempt to report targets up to 6500-mm, but this capability is not guaranteed.

The MB7853 and MB7854 have a maximum range of 16500-mm. These sensors will report in millimeter resolution between 500-mm and 5000-mm, and will round to the nearest 10-mm beyond this range.

Minimum Distance

The MB7850 and MB7851 have a minimum reported distance of 50-mm, and the MB7853 and MB7854 have a minimum reported distance of 300-mm. However, the TankSensor will detect the presence of targets to the front of the horn. Liquid levels closer than minimum reported distance will typically be reported as the minimum.

Additionally, the MB7853 and MB7854 will report range in roughly 20-mm increments below 500-mm.

Application Specific Filters and Most Likely Filtering

The TankSensor line is designed to be used in liquid level applications, and therefore it is assumed a target will always be present. Either a liquid, or the bottom of an empty tank is assumed to be present. The sensor will make automatic adjustments to its sensitivity if no target is found. If no target is found with the sensor at its maximum hardware sensitivity, max distance will be reported. Additionally, the TankSensor line is equipped with a Most-Likely target filter, meaning that they will range to the largest target, rather than the first detectable one. The combination of these factors means that in environments where there is no large reflector within range, the sensor may have an increased chance of reporting the range to peripheral targets such as support brackets and other objects at wider beam angles.

Power Consumption

The average and peak current draw for each model of TankSensor is listed in the table below. Peak current is used during sonar pulse transmit and is very brief.

Part Number	3.3V Avg. Current	3.3V Peak Current	5.0 Avg. Current	5.0 Peak Current	5.5V Avg. Current	5.5V Peak Current
MB7850	1.6mA	27mA	1.8mA	47mA	N/A	N/A
MB7851	1.6mA	27mA	1.8mA	47mA	N/A	N/A
MB7853	2.2mA	16mA	2.7mA	29mA	N/A	N/A
MB7854	N/A	N/A	N/A	N/A	3.3mA	30mA

Sensor Timing Diagrams

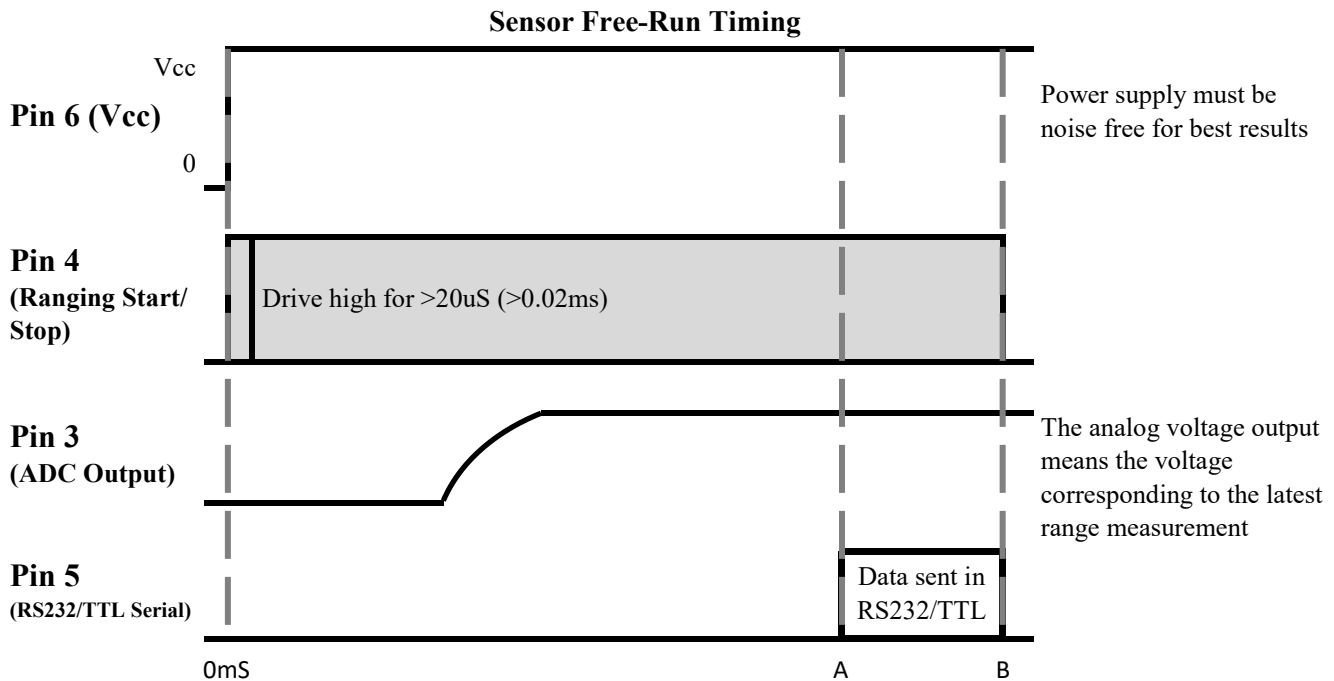
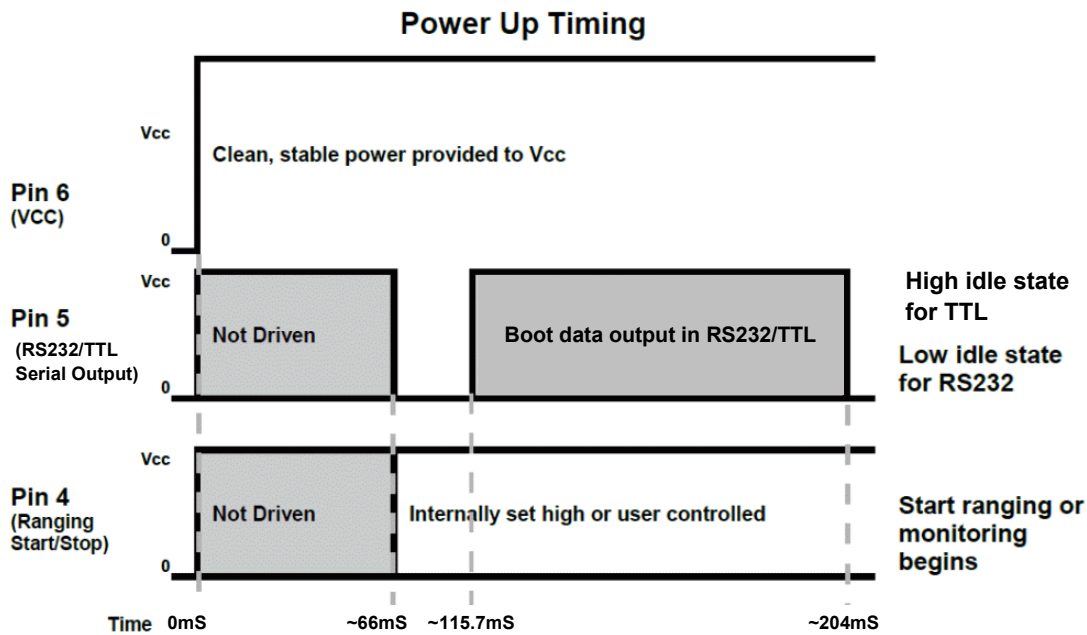

Product	Maximum Refresh Rate	Serial Data Reported (A)	End of Range Cycle (B)
MB7850	4.032 Hz	~236.14mS	~248mS
MB7851	1.95 Hz	~487.1mS	~512.1mS
MB7853 and MB7854	1.2 Hz	~814.5mS	~828.31mS

Timing Description

204mS after power-up, the TankSensor is ready to begin ranging. If Pin-4 is left open or held high (20uS or greater), the sensor will take a range reading. The TankSensor checks Pin-4 at the end of every cycle. Range data can be acquired once every period. Each period starts by Pin-4 being high or open, after which the TankSensor calibrates and calculates for 11.5mS, and after which, the ultrasonic waves are sent. The sensor then determines the range to the target. Next the analog voltage is set. Then serial data is sent. The most accurate range output on the TankSensor is the serial output.

Note: The MB7851, MB7853, and MB7854 have a substantial amount of additional reading-to-reading filtering which allows them to remain more stable and provide more accurate range output. However, this means that it can take several range readings for these models to switch to a new target if there is a sudden shift in target location. Under ideal conditions switching targets will take 5 range cycles, resulting in an effective filtering rate of 0.39Hz for the MB7851 and 0.24Hz for the MB7853 and MB7854.

Voltage vs Temperature

The graphs below shows minimum operating voltage of each sensor verses temperature.

MB7854 Operating Voltage shall always be 5.5V or higher at all temperatures.

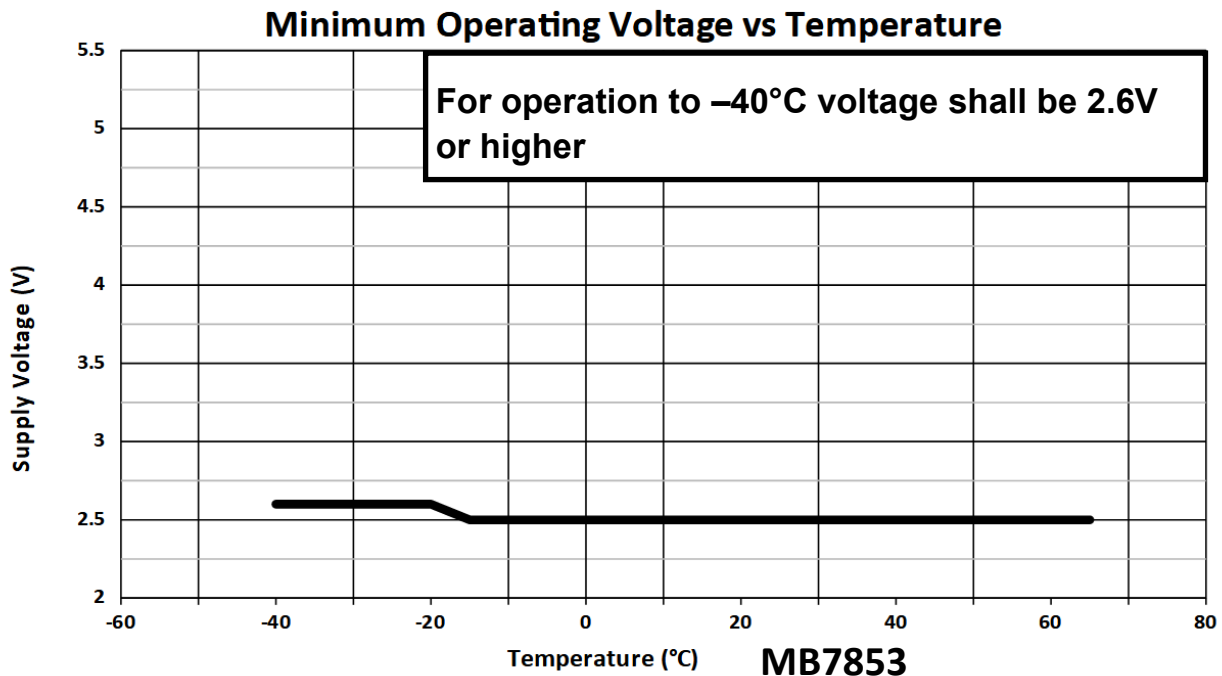
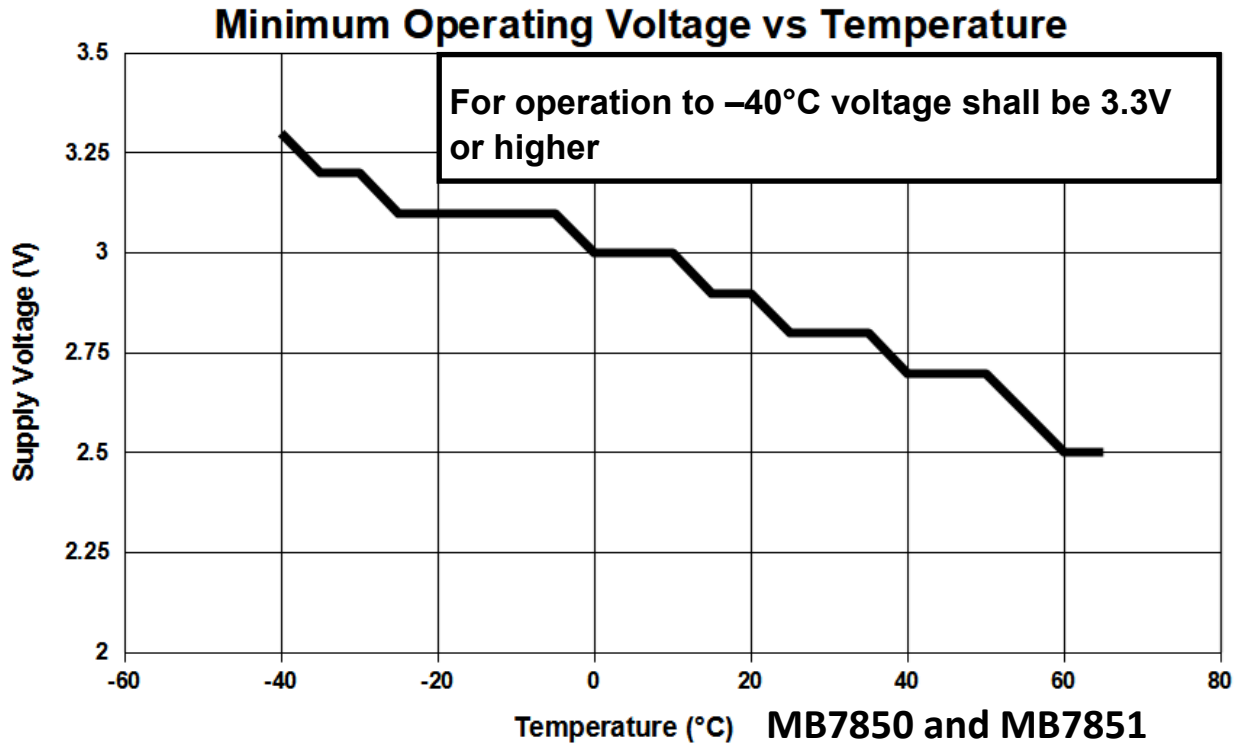

Attenuation of Ultrasound

Attenuation, specifically absorption of sound through the air, restricts the maximum range of ultrasonic rangefinders. As sound waves travel through the air, that air absorbs some of their energy. High frequency sounds like ultrasound are often attenuated more quickly than lower frequency sounds. In addition to frequency, relative humidity also affects attenuation. Warm air masses with low relative humidity will typically attenuate sound waves faster. As such performance of ultrasonic devices may be limited at low relative humidity, especially when trying to detect targets at longer ranges

Background Information Regarding our Beam Patterns

Each TankSensor has an individually calibrated beam pattern, and is matched to provide the approximate detection pattern shown in this datasheet. This allows end users to select the part number that matches their given sensing application. Each part number has a consistent field of detection so additional units of the same part number will have similar beam patterns. The beam plots are provided to help identify an estimated detection zone for an application based on the acoustic properties of a target versus the plotted beam patterns.

Each beam pattern is a 2D representation of the detection area of the sensor. The beam pattern is actually shaped like a 3D cone (having the same detection pattern both vertically and horizontally). Detection patterns for dowels are used to show the beam pattern of each sensor. Dowels are long cylindered targets of a given diameter. The dowels provide consistent target detection characteristics for a given size target which allows easy comparison of one TankSensor to another TankSensor.

For each part number, the five patterns (A, B, C, D and E) represent the detection zone for a given target size. Each beam pattern shown is determined by the sensor's part number and target size.

The actual beam angle changes over the full range. Use the beam pattern for a specific target at any given distance to calculate the beam angle for that target at the specific distance. Generally, smaller targets are detected over a narrower beam angle and a shorter distance. Larger targets are detected over a wider beam angle and a longer range.

Beam Pattern Target Shapes

A 6.1-mm (0.25-inch) diameter dowel 4ft length

B 2.54-cm (1-inch) diameter dowel 4ft length

C 8.89-cm (3.5-inch) diameter dowel 4ft length

D 11-inch wide board 4ft in length moved left to right with the board parallel to the front sensor face. This shows the sensor's range capability.

E 2" x 2" Cube Corner Reflector

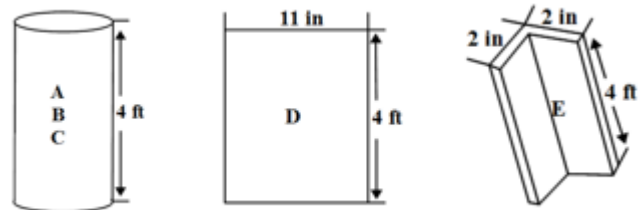

Corner Reflectors

Sometimes when using an ultrasonic sensor, users experience detection of unwanted objects that appear outside the expected beam pattern. These types of detections are the result of reflectors present in the environment. Corner reflectors can be surprisingly small, yet present a large reflection back to the sensor. Certain objects are prone to causing corner reflections. One of the most common corner reflectors is two flat surfaces joining together to create a 90° angle. A halfcircle also acts as a similar reflector. You can learn more about corner reflectors in our [Cube Corner Reflectors](#) article.

MB7850 & MB7851 TankSensor Beam Pattern and Uses

The MB7850 and MB7851 detect liquid from 0-mm to 5000-mm and provide range information from 50-mm to 5000-mm with a 1-cm (MB7850) or 1-mm (MB7851) resolution. This sensor is designed for applications where liquid level detection is needed out to a maximum of 5 meters.

MB7850-BXX MB7851-BXX

TankSensor Beam Pattern

Sample results for measured beam pattern are shown on a 30-cm grid. The detection pattern is shown for dowels of varying diameters that are placed in front of the sensor.

- A 6.1-mm (0.25-inch) diameter dowel
- B 2.54-cm (1-inch) diameter dowel
- C 8.89-cm (3.5-inch) diameter dowel
- D 11-inch wide board moved left to right with the board parallel to the front sensor face. This shows the sensor's range capability.
- E 2" x 2" Cube Corner Reflector

Note: For people detection the pattern typically falls between charts A and B.

- Partial Detection
- 5.0 V
- 3.3 V

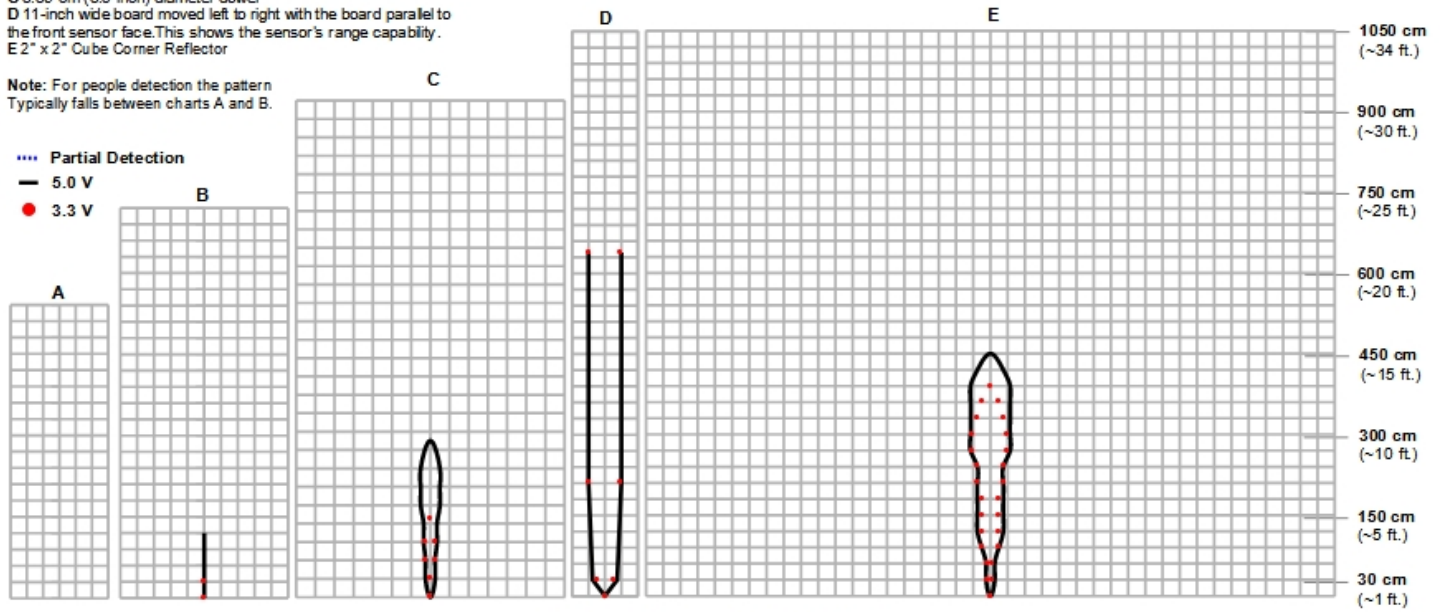

Beam Characteristics are Approximate

MB7850 & MB7851 Features and Benefits

- 5 meter range detection and outputs
- High acoustic power output
- Readings can occur up to every 248ms, 4.032Hz rate (MB7850) or 512ms, 1.95Hz rate (MB7851)
- Triggered operation provides the range reading as desired
- Fast measurement cycle
- Quality narrow beam characteristics
- Low cost, long range IP67 sensor
- Centimeter (MB7850) or millimeter (MB7851) resolution

MB7850 & MB7851 Applications and Uses

- Liquid Distance Measuring
- Industrial sensor

MB7853 & MB7854 TankSensor Beam Pattern and Uses

The MB7850 and MB7851 detect liquid from 0-mm to 16500-mm and provide range information from 300-mm to 16500-mm with 1-mm resolution from 500-mm to 5000-mm. This sensor is designed for applications where liquid level detection is needed out to a maximum of 16.5 meters.

MB7853-BXX, MB7854-BXX

TankSensor Beam Pattern

Sample results for measured beam pattern are shown on a 30-cm grid. The detection pattern is shown for dowels of varying diameters that are placed in front of the sensor.

- A 6.1-mm (0.25-inch) diameter dowel
- B 2.54-cm (1-inch) diameter dowel
- C 8.89-cm (3.5-inch) diameter dowel
- D 11-inch wide board moved left to right with the board parallel to the front sensor face. This shows the sensor's range capability.
- E 2" x 2" Cube Corner Reflector

Note: For people detection the pattern typically falls between charts A and B.

- 5.0V
- ◆ 3.3V

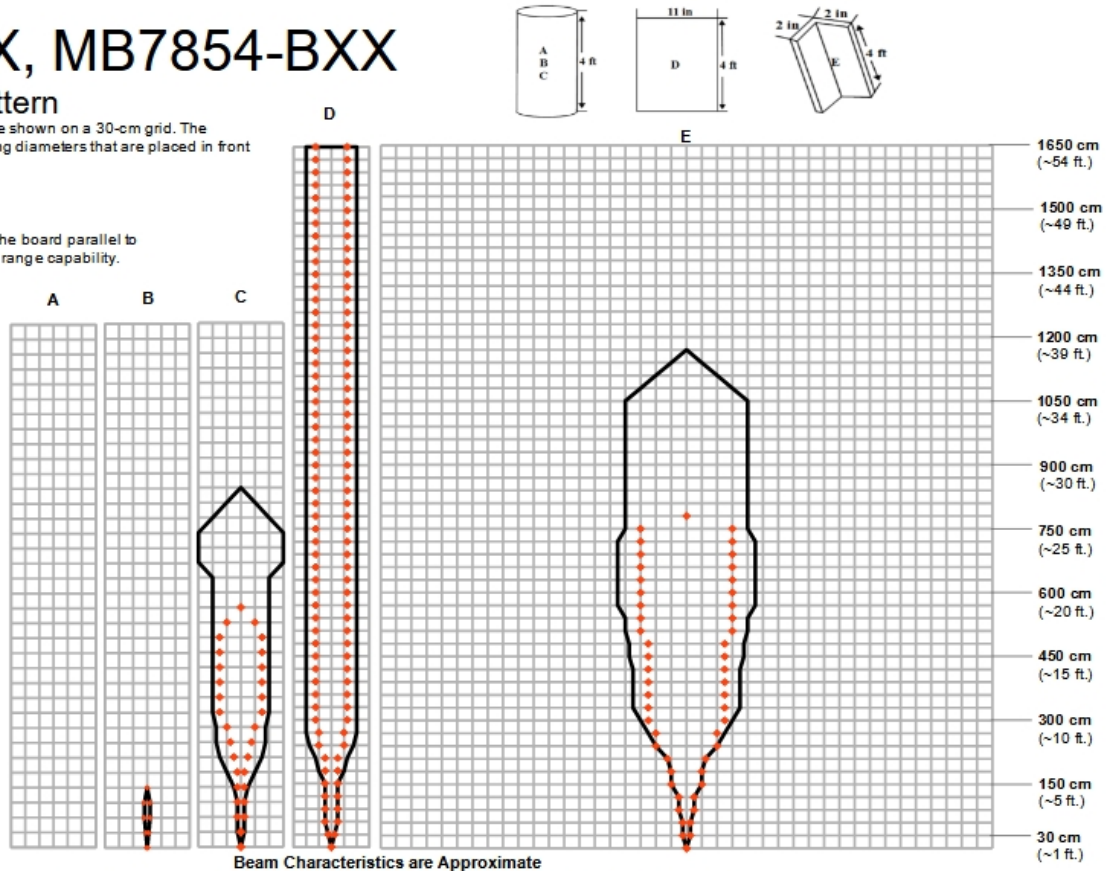

MB7853 & MB7854

Features and Benefits

- 16.5 meter range detection and outputs
- High acoustic power output
- Readings can occur up to every 829ms, 1.2Hz rate
- Triggered operation provides the range reading as desired
- Fast measurement cycle
- Quality narrow beam characteristics
- Low cost, long range IP67 sensor
- Approximately 20-mm resolution from 300-mm to 500-mm
- 1-mm resolution from 500-mm to 5000-mm
- 10-mm resolution from 5000-mm to 16500-mm

MB7853 & MB7854

Applications and Uses

- Liquid Distance Measuring
- Industrial sensor

Mechanical Dimensions

The sensor is housed in a robust ABS housing, designed to meet the IP67 water intrusion standard. The top thread is a 3/4"-14 NPS, with the end of the horn being a 2" NPS thread.

MB7850 & MB7851 with no wire attach

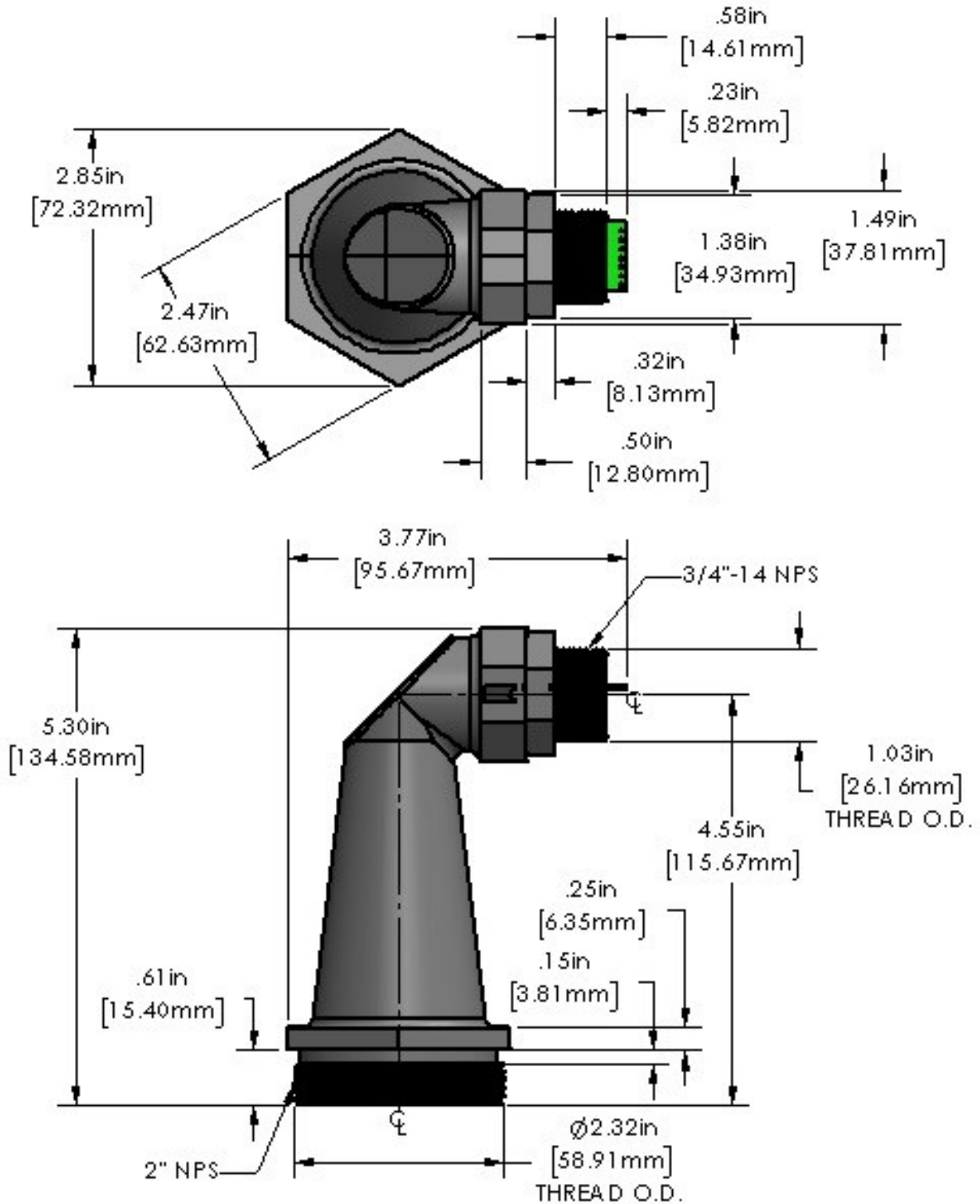

Weight is 80 grams

MB7850 & MB7851 with wire attach

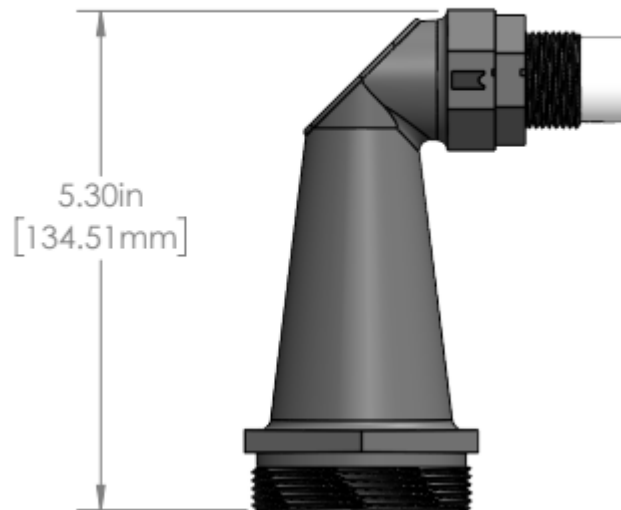
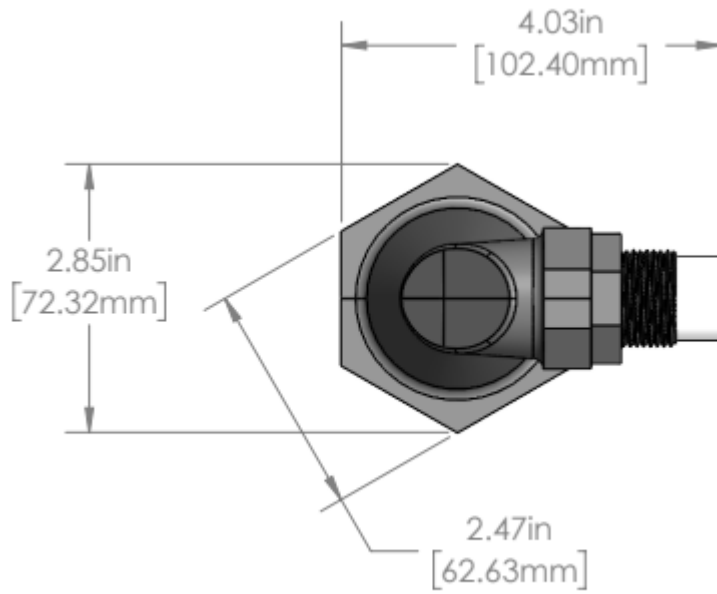

Range “0” Location

TankSensors report the range to distant targets starting from the front of the sensor as shown in the diagrams below.

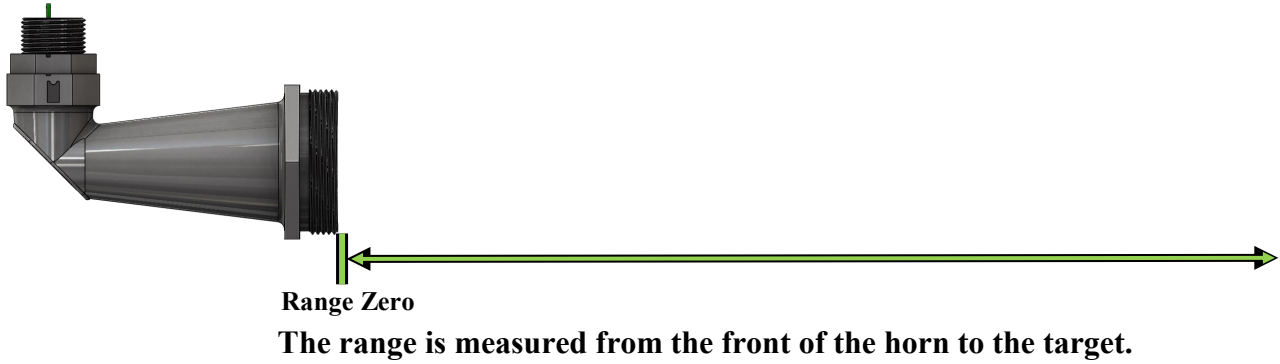

Additional Features and Information

Auto Sensitivity Adjustment

Each time before the TankSensor takes a range reading it auto calibrates. The sensor then uses this data to range objects. If the temperature, humidity, or applied voltage changes during sensor operation, the sensor will continue to function normally. (By default, the sensors do not apply compensation for the speed of sound change verses temperature to any range readings. See Speed of Sound Vs. Temperature section for more information.)

Supply Voltage Compensation

During power up, the TankSensor will calibrate itself for the supply voltage. Additionally, the sensor will compensate if the supplied voltage gradually changes.

If the average voltage applied to the sensor changes faster than 0.5V per second, it is best to remove and reapply power to the sensor. For best operation, the sensor requires noise free power. If the sensor is used with noise on the supplied power or ground, the accuracy of the readings may be affected. Typically, adding a 100uF capacitor at the sensor between the V+ and GND pins will correct most power related electrical noise issues.

Real-time Noise Rejection

While the TankSensor is designed to operate in the presence of noise, best operation is obtained when noise strength is low and desired signal strength is high. Hence, the user is encouraged to mount the sensor in such a way that minimizes outside acoustic noise pickup. In addition, keep the DC power to the sensor free of noise. This will let the sensor deal with noise issues outside of the user's direct control (Even so, in general, the sensor will still function well even if these things are ignored). Users are encouraged to test the sensor in their application to verify usability.

Shielded Cable Attach Option

For simple integration of our sensors into end-user applications, MaxBotix has developed the Shielded Cable Attach Option to create a completely IP67 rated TankSensor. The standard Shielded Cable Attach Option uses 3 feet of the MaxSonar MB7954 Shielded Cable (MB7984 when attached by MaxBotix) with an epoxy filled cap to fully protect the pin-out of the TankSensor. Additional cable length can be specified and purchased using part number MB7984.

WR Exposed Materials

The exposed materials of a properly mounted TankSensor are: Parylene coated Aluminum, ABS, & silicone rubber (VMQ). Additionally, some exposed components may contain ASA.

Please note: ABS is known to be incompatible with gasoline and other fuels. The sensor may be damaged in environments where the housing is exposed to vapors such as these.

F-Option

In addition to the standard MaxSonar WR, MaxBotix Inc. has developed the F-Option for additional protection necessary in a few hazardous chemical environments. Extremely corrosive gases or liquids can degrade or compromise the operation of the sensing unit. As a result, we offer a more chemically inert seal which allows our sensors to operate in all but the harshest of chemical environments. In addition to the chemical resistance, the sensor has improved performance in wet environments.

The exposed materials of a properly mounted TankSensor with the F-Option added are: Parylene, ABS, & Fluorosilicone O-Ring. (with an additional back up FEP Teflon® seal).

Please Note: Our sensors are designed for operation in normal atmosphere (air). Please be aware that the speed of sound and atmospheric attenuation may change as a result of the transmission properties of different chemical/air

Please contact MaxBotix at sensors@maxbotix.com for any additional information regarding F-Option.

Speed of Sound Vs. Temperature

The MB7850 and MB7851 do not have built in temperature compensation. If temperature compensation is required, please review the formula below which can be used to manually apply compensation for temperature.

$$D_m = \frac{T_{OF} * 20.05 * \sqrt{T_C + 273.15}}{2}$$

Where:

D_m = Distance in meters adjusted for temperature

T_{OF} = Time of Flight in Seconds

This can be calculated by taking the range reported by the sensor in centimeters and multiplying it by 58 μ S/cm or by taking the range in millimeters and multiplying it by 5.8 μ S/mm. This will give a value in Microseconds. Then divide that by 1,000,000 to get a Time of Flight in Seconds.

T_C = Temperature in Degrees Celsius

The MB7853 and MB7854 do have built in temperature compensation, however this feature is turned off by default. In environments with a large amount of temperature variance across the range of the sensor such as heated tanks or tanks exposed to direct sunlight, the onboard temperature sensor can be biased towards the temperature near the mounting location. This can cause a great deal of inaccuracy and instability and as such the temperature sensor is turned off by default. If the sensor is being used in an environment with a smaller temperature gradient, the built in temperature compensation can be enabled by using the available serial commands. Unless commanded to use the temperature sensor, the TankSensor will assume an ambient air temperature of 20 Degrees Celsius.

Part Numbers

All part numbers are a combination of a six-character base followed by a dash and a three-digit product code. Please review the following table for more information on the three-digit product code.

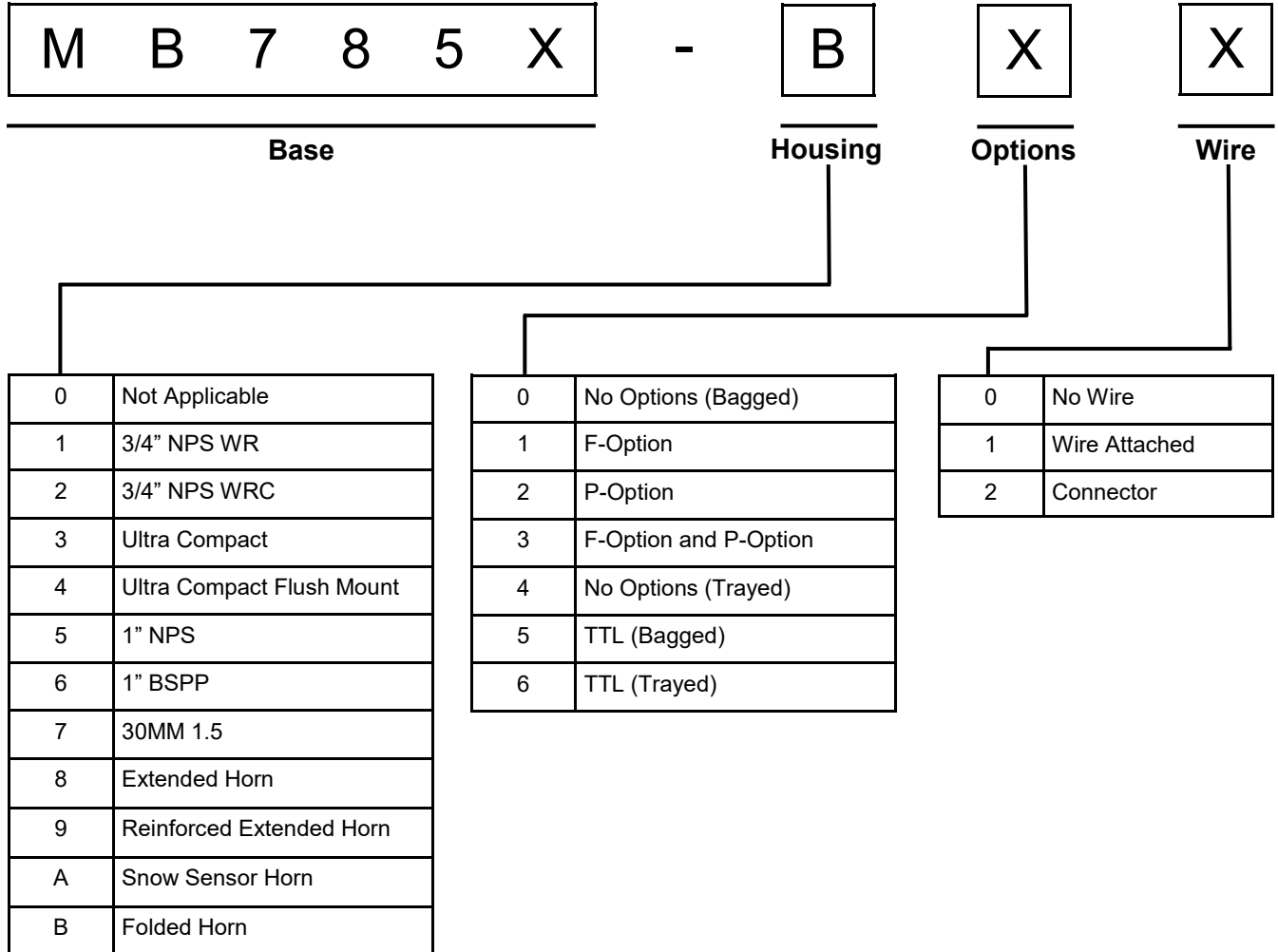

The following tables display all of the active and valid part numbers for these products.

Active Part Numbers for the TankSensor line							
MB7850-B20	MB7850-B21	MB7850-B30	MB7850-B31				
MB7851-B20	MB7851-B21	MB7851-B30	MB7851-B31				
MB7853-B20	MB7853-B21	MB7853-B30	MB7853-B31				
MB7854-B20	MB7854-B21	MB7853-B30	MB7854-B31				

After reviewing this datasheet, do you have any more questions?

We offer Technical Support on all of our products even if you purchased them through one of our many vendors worldwide.

You can **fill out a Technical Support form** for assistance on a sensor here --> [Technical Support](#)

Not sure which sensor you need for your application?

We offer Sensor Selection Assistance, click the link here to fill out a form for support --> [Sensor Selection Help](#)

Looking for tutorials to help you get started?

[Frequently Asked Questions about Our Sensors](#)

We receive many questions about our products and services. This resource offers answers to common inquiries we receive about our product lines and their application.

[Fully Calibrated Beam Patterns](#)

All of our sensors are factory calibrated to provide consistent beam patterns, detection zones, to fit into a wide variety of applications. In our product lines, each model number comes with a different beam pattern that reflects the sensitivity and the detection zone of how it sees a target. Additionally, we strive to maintain consistency between our finished products, and you will see little to no deviation between sensors of the same model. This allows you to have confidence in your final application when using multiple sensors.

[Understanding Range Readings](#)

The success of an application may hinge upon knowing the exact location of a target. However, a sensor may report one meter even if the target is not exactly one meter away from the sensor. Sensor specifications, such as resolution, precision, and accuracy, help you to understand sensor performance.

[How to Use Multiple Ultrasonic Sensors](#)

This guide covers three ways to run your sensors in a Multiple Sensor environment and issues you may face.

Contact us now with any questions at sensors@maxbotix.com or call +1-218-454-0766.

Please call during our preferred business hours of 8:00 am – 4:30 pm CST on Monday through Thursday and 8:00 am – 2:00 pm CST on Friday, or you may leave us a voicemail anytime.