



617-7125 MHz, 2-5 dBi Gain, Omni-directional Antenna with Magnetic NMO Mount, N-Female Connector

Antennas Technical Data Sheet

PEANMOB1002-NF

Features

- Outdoor Rated Omni Directional Antenna
- 2-5 dBi Gain
- Easy to install magnetic mount offering temporary plug and play installation
- NMO Magnetic Mount, Black ABS Radome
- 2.5:1 VSWR Max
- 10 Foot, Black Low-Loss LMR195 Equivalent
- N-Female Connector

Applications

- Infotainment systems, Routers, Wi-Fi hotspots, HD video transmission, Gateways, Dash cameras, Public transportation Public Safety Networks
- Connected cars or self driving cars, Fleet management, Logistics
- IoT, Industrial IoT, Zigbee, Bluetooth, Wi-Fi

Description

The PEANMOB1002-NF from Pasternack is an omnidirectional antenna with a 5 dBi gain that transmits high-power signals and faster speed. This in-building antenna comes with a magnetic NMO mount specifically designed for high-performance applications. Our high-quality omni antenna is available in black color and can be procured with no order limit. This vertically polarized antenna has a frequency range of 617 to 7125 MHz, which is ideal for indoor low-profile, in-building, and mobile applications.

The NMO-type magnetic mount on Pasternack's PEANMOB1002-NF omnidirectional antenna makes it an ideal solution when the portability of the antenna is needed. This NMO antenna mount is constructed with a heavy-duty magnet to ensure secure mounting. The magnetic base allows a temporary plug-and-play installation. No drilling is required for the installation of this antenna mount, making it easy to fine-tune the antenna location. This magnetic mount has an N-type female connector and can be used for WLAN, Wi-Fi, public safety, and mobile RF applications.

Pasternack has one of the largest in-stock selections of omnidirectional in-building antennas with the same-day shipment. Make your online purchase right now to take advantage of our same-day shipping. For further information on similar products, our expert technical support and knowledgeable sales team can help you get the ideal vertically polarized antenna with a magnetic NMO mount for your requirements.

Configuration

Design	Omni
Band Type	Single
Radiation Pattern	Omni Directional
Polarization	Vertical
Connector Type	N Female
Number of Ports	1

Electrical Specifications

Description	Minimum	Typical	Maximum	Units
Frequency Range	617		7,125	MHz
Input VSWR			1.5:1	
Gain	2		5	dBi
Input Power			100	Watts

Click the following link (or enter part number in "SEARCH" on website) to obtain additional part information including price, inventory and certifications: [617-7125 MHz, 2-5 dBi Gain, Omni-directional Antenna with Magnetic NMO Mount, N-Female Connector PEANMOB1002-NF](#)



617-7125 MHz, 2-5 dBi Gain, Omni-directional Antenna
with Magnetic NMO Mount, N-Female Connector

Antennas Technical Data Sheet

PEANMOB1002-NF

Mechanical Specifications

Size

Overall Length	4.95 in [125.73 mm]
Width	3 in [76.2 mm]
Height	3 in [76.2 mm]
Weight	1.25 lbs [566.99 g]

Compliance Certifications (see [product page](#) for current document)

Plotted and Other Data

Notes:

617-7125 MHz, 2-5 dBi Gain, Omni-directional Antenna with Magnetic NMO Mount, N-Female Connector from Pasternack Enterprises has same day shipment for domestic and International orders. Our RF, microwave and millimeter wave products maintain a 99.4% availability and are part of the broadest selection in the industry.

Click the following link (or enter part number in "SEARCH" on website) to obtain additional part information including price, inventory and certifications: [617-7125 MHz, 2-5 dBi Gain, Omni-directional Antenna with Magnetic NMO Mount, N-Female Connector PEANMOB1002-NF](#)

URL: <https://www.pasternack.com/617-7125-mhz-2-5-dbi-gain-omni-directional-antenna-with-magnetic-nmo-mount-n-female-connector-peanmob1002-nf-p.aspx>

The information contained in this document is accurate to the best of our knowledge and representative of the part described herein. It may be necessary to make modifications to the part and/or the documentation of the part, in order to implement improvements. Pasternack reserves the right to make such changes as required. Unless otherwise stated, all specifications are nominal. Pasternack does not make any representation or warranty regarding the suitability of the part described herein for any particular purpose, and Pasternack does not assume any liability arising out of the use of any part or documentation.

PEANMOB1002-NF CAD Drawing

617-7125 MHz, 2-5 dBi Gain, Omni-directional Antenna with
Magnetic NMO Mount, N-Female Connector

F E D C B A

1 2 3 4 5 6

ZONE	REV.	DESCRIPTION	DATE	CHANGED BY	APPROVED BY
	A	INITIAL RELEASE	02/27/2023	BPUCHASKI	KHIETPAS

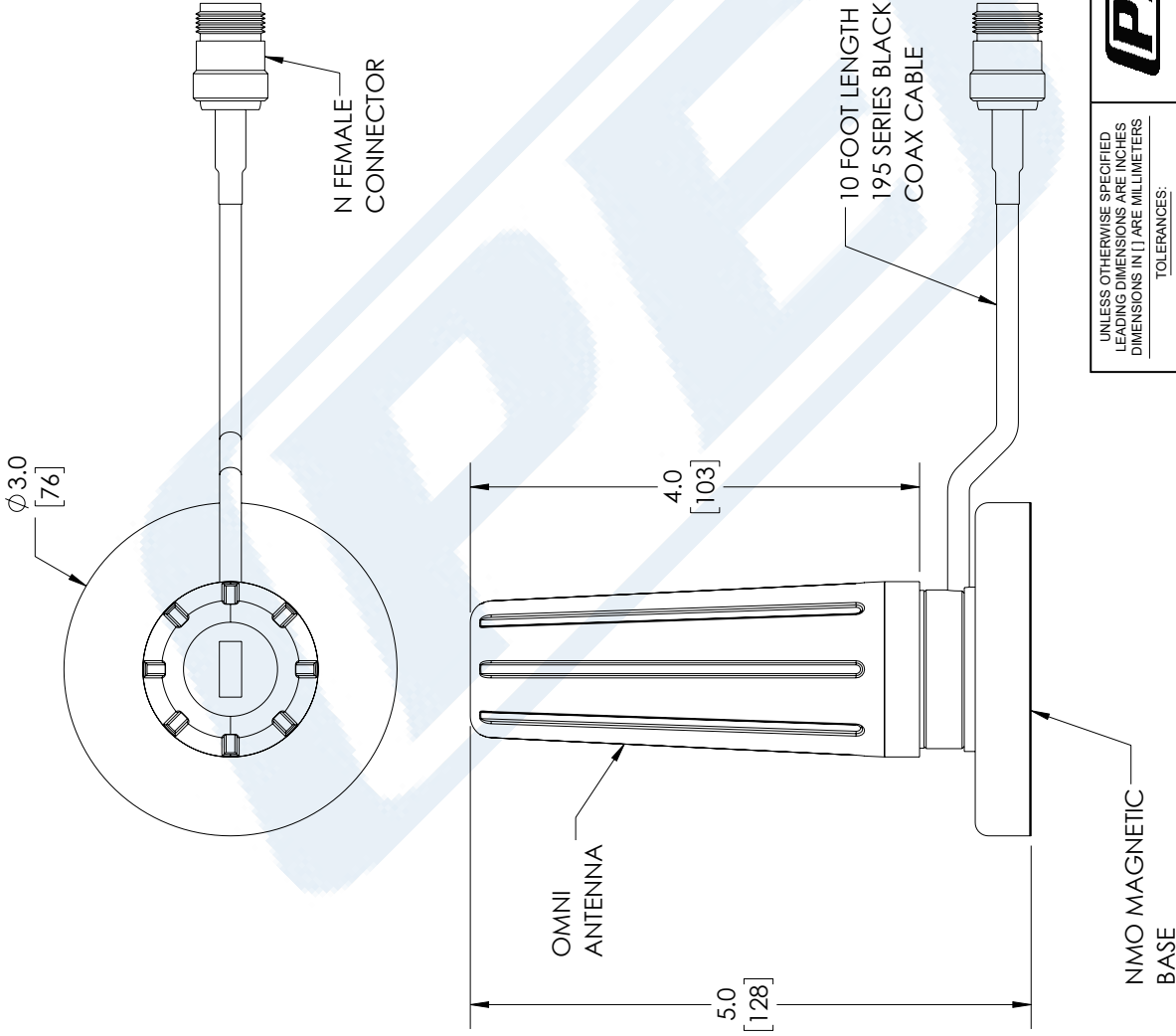

PE PASTERNAK
an INFINITIB brand

Website: www.Pasternack.com
Phone: 1.866.727.8376 | 1.949.261.1920

DESCRIPTION
617-7125MHz 3dBi Omni Antenna with NMO, Black, N-Female Connector

INTERPRET ALL DIMENSIONS AND TOLERANCES PER ASME Y14.5

SCALE NONE SHEET 1 OF 1

UNLESS OTHERWISE SPECIFIED LEADING DIMENSIONS ARE INCHES DIMENSIONS IN [] ARE MILLIMETERS

TOLERANCES:
 .X = ±.2 [5] | FRACTIONS ± 1/32
 .XX = ±.02 [.5] | ANGLES ± 1°
 .XXX = ±.005 [.13]

CABLE LENGTH TOLERANCES:
 ≤12 [305] = +1 [25] / -0
 >12 [305] ≤ 60 [1524] = +2 [51] / -0
 >60 [1524] ≤ 120 [3048] = +4 [102] / -0
 >120 [3048] ≤ 300 [7620] = +6 [152] / -0
 >300 [7620] = +5% / -0

ALL DIMENSIONS ARE FOR REFERENCE ONLY AND SUBJECT TO CHANGE WITHOUT NOTICE

SIZE A CAGE CODE 53919 DRAWN BY BPUCHASKI ITEM NO. PEANMOB1002-NF REV A

THE INFORMATION CONTAINED IN THIS DRAWING IS THE SOLE PROPERTY OF INFINITE ELECTRONICS, INC. ANY REPRODUCTION IN PART OR WHOLE WITHOUT THE WRITTEN PERMISSION OF INFINITE ELECTRONICS, INC. IS PROHIBITED. THESE COMMODITIES, TECHNOLOGY OR SOFTWARE WERE EXPORTED FROM THE UNITED STATES IN ACCORDANCE WITH THE EXPORT ADMINISTRATION REGULATIONS. DIVERSION CONTRARY TO U.S. LAW PROHIBITED.