

# GN 2246

Aluminum / Stainless Steel

# Beam Couplings

with Clamping Hub



**JWWINCO**  
A Ganter Company

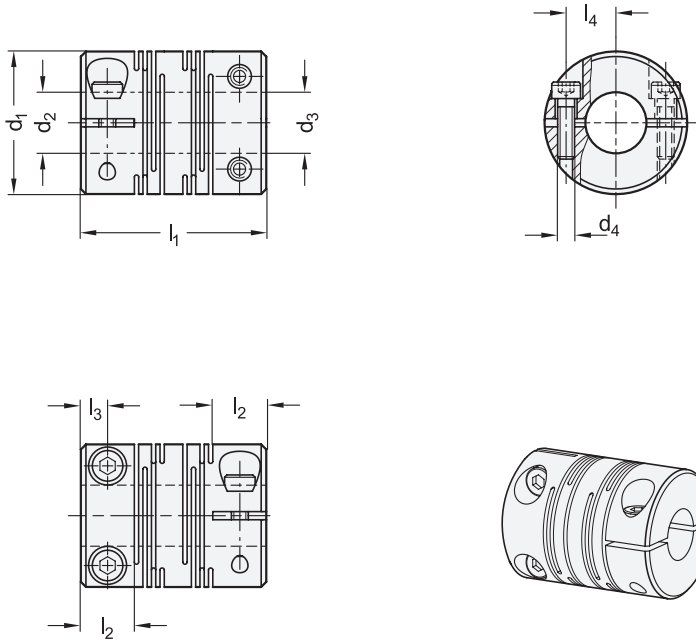

**SS** Stainless Steel

**2** Bore code

**B** Without keyway

## Bellows couplings with metric-metric bore

Dimensions in: millimeters - inches

<b>1</b> $d_1$	<b>3</b> $d_2 - d_3$ H8 Bore (mm-mm) Recommended shaft tolerance h7					
12 0.47	4-4	4-5	5-5	-	-	-
16 0.63	5-5	5-6	6-6	-	-	-
20 0.79	5-5	5-6	5-8	6-6	6-8	8-8
25 0.98	6-6	6-8	6-10	8-8	8-10	10-10
32 1.26	10-10	10-12	12-12	-	-	-

## Bellows couplings with metric-inch bore

Dimensions in: millimeters - inches

<b>1</b> $d_1$	<b>3</b> $d_2 - d_3$ H8 Bore (mm-in) Recommended shaft tolerance h7					
20 0.79	5-1/4	6-1/4	8-1/4	-	-	-
25 0.98	6-1/4	8-1/4	8-3/8	10-1/4	10-3/8	-
32 1.26	10-3/8	12-3/8	-	-	-	-

$d_1$	$d_4$ Thread	$l_1$	$l_2$ Recommended shaft insertion depth	$l_3$	$l_4$	Tightening torque of the screw in Nm $\approx$
12 0.47	M 2	18.5 0.73	5 0.20	2.5 0.10	4 0.16	0.5
16 0.63	M 2.5	23 0.91	6.5 0.26	3.25 0.13	5 0.20	1
20 0.79	M 2.5	26 1.02	7.5 0.30	3.75 0.15	6.5 0.26	1
25 0.98	M 3	31 1.22	8.5 0.33	4.25 0.17	9 0.35	1.5
32 1.26	M 4	41 1.61	12 0.47	6 0.24	11 0.43	2.5

Dimensions in: millimeters - inches

Aluminum d <sub>1</sub>	Rated torque in Nm	Max. speed (min <sup>-1</sup> )	Moment of inertia in kgm <sup>2</sup>	Static torsional stiffness in Nm/rad	Max. shaft misalignment		
					Lateral	Axial	Angular in °
12 0.47	0.4	52,000	7.8 x 10 <sup>-8</sup>	45	0.1 0.004	± 0.3 ±0.012	2
16 0.63	0.5	39,000	3.4 x 10 <sup>-7</sup>	80	0.1 0.004	± 0.4 ±0.016	2
20 0.79	1	31,000	9.1 x 10 <sup>-7</sup>	170	0.1 0.004	± 0.4 ±0.016	2
25 0.98	2	25,000	2.6 x 10 <sup>-6</sup>	380	0.15 0.006	± 0.5 ±0.020	2
32 1.26	4	19,000	9.7 x 10 <sup>-6</sup>	500	0.15 0.006	± 0.5 ±0.020	2

Stainless Steel d <sub>1</sub>	Rated torque in Nm	Max. speed (min <sup>-1</sup> )	Moment of inertia in kgm <sup>2</sup>	Static torsional stiffness in Nm/rad	Max. shaft misalignment		
					Lateral	Axial	Angular in °
12 0.47	0.3	52,000	2.2 x 10 <sup>-7</sup>	64	0.1 0.004	± 0.2 ±0.079	2
16 0.63	0.5	39,000	9.0 x 10 <sup>-7</sup>	85	0.1 0.004	± 0.3 ±0.012	2
20 0.79	1	31,000	2.5 x 10 <sup>-6</sup>	250	0.1 0.004	± 0.3 ±0.012	2
25 0.98	2	25,000	7.1 x 10 <sup>-6</sup>	330	0.15 0.006	± 0.4 ±0.016	2
32 1.26	3.5	19,000	2.7 x 10 <sup>-5</sup>	850	0.15 0.006	± 0.5 ±0.020	2

**Specification**

- Aluminum **AL**
  - Anodized finish, natural color
  - Temperature resistant up to 302 °F (150 °C)
  - Socket cap screws DIN 912 Steel, blackened finish
- Stainless steel AISI 303 **NI**
  - Temperature resistant up to 392 °F (200 °C)
  - Socket cap screws DIN 912 Stainless steel AISI 304Cu
- ISO Fundamental Tolerances → page QVX
- Stainless Steel Characteristics → page QVX
- RoHS compliant

**On request**

- Inch bores
- Bore with keyway

**Information**

Beam couplings GN 2246 transmit angle positions and torques with extreme precision and no backlash. They are manufactured of a single piece and offer high torsional stiffness thanks to the alternating slits. The clamping hubs make beam couplings very easy to assemble.

They are used in applications where precise position and movement transmission is required, such as in the drive systems of position measuring systems and in test benches.

The Stainless Steel version can also be used in environments requiring high corrosion resistance, such as in medical technology (CAT scanners) and food-processing equipment (confectionary machines).

see also...

- Bellows Couplings GN 2244 → page QVX
- Elastomer Jaw Couplings GN 2240 (with Clamping Hub) → page QVX
- Installation Information on Couplings → page XYZ
- Technical Information on Couplings → page XYZ

How to order	
1	Outside diameter d <sub>1</sub>
2	Bore code
3	Bore d <sub>2</sub> -d <sub>3</sub>
5	Material

GN 2246 - 32 - B10 - 3/8 - NI