

符合"DLK环境管理物质技术标准"

工程变更通知单 ECN(DCN) NO.	版本 REV	日期 DATE	说明 DESCRIPTION	改变 CHANGE	承认 APPRO.
KSECN23032	A	20231012	NEW RELEASE	—	—

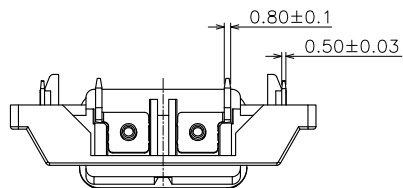

NOTE:
 1. MATERIAL:
 1.1 Housing: PA66 UL94v-0, color: Black
 1.2 Contact: Copper alloy
 1.3 Soldering Pin: Copper alloy
 1.4 Rivet: Ferro alloy
 2. PLATING:
 2.1 Contact: Nickel plated overall
 2.2 Soldering Pin: Sn plated, Nickel underplated
 3. MECHANICAL:
 3.1 Mating force: 10~50N
 3.2 Unmating force: 60N Max
 3.3 Durability: 5000 cycles
 4. ELECTRICAL:
 4.1 Current Rating: 2.5/7A
 4.2 Voltage Rating: 125/250V
 4.3 Dielectric strength: 2000V AC FOR 1 minute
 4.4 Insulation Resistance: 100MΩ Min.
 4.5 Contact Resistance: 30mΩ Max
 5. Operating Temperature: -55°C to +85°C
 6. PACKING: BOX

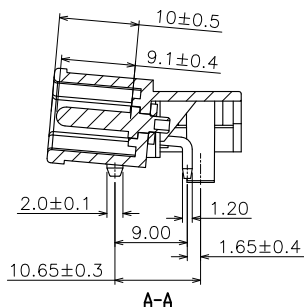
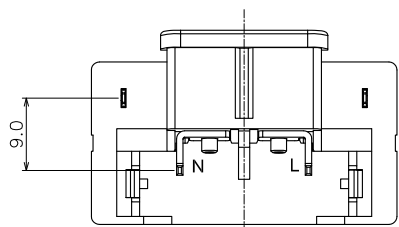
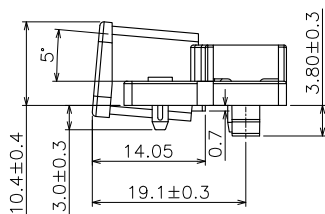
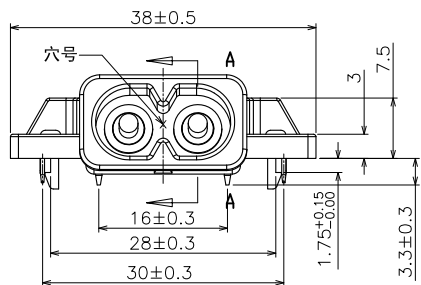
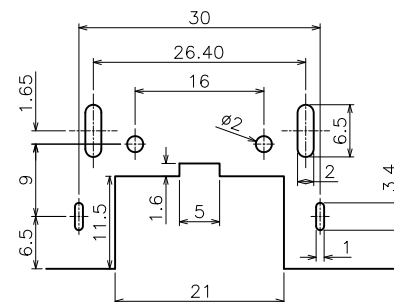

RECOMMENDED PCB LAYOUT
 TOLERANCE: ±0.05mm

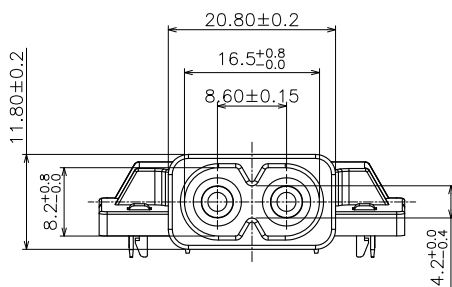
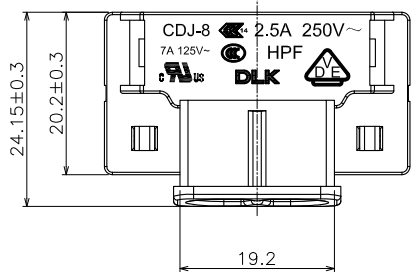

GENERAL TOLERANCE
 UNLESS OTHERWISE NOTED

Angle	±5°
X.	±0.35
.X	±0.25
.XX	±0.15
.XXX	±0.10



德力康电子科技有限公司



DELIKANG ELECTRONICS TECHNOLOGY CO.,LTD

4	RIVET	2	Ferro alloy	TIN
3	SOLDERING	2	Copper alloy	MIST TIN
2	CONTACT	2	Copper alloy	Nickel
1	HOUSING	1	PA66 UL 94V-0	BLACK
NO.	ITEM	Q'TY	DESCRIPTION	FINISH

C	名称 TITLE:	AC 2PIN沉板式			
	档案名称 FILE NAME:	C-ACT8A-00-00	料号 PART NO.:	78A02B43000	
DRAWING	蒋召	CHECKED	覃智森	APPROVED	段国强
UNIT:	mm	SCALE	1:1	SHEET: 1 of 1	