

符合"DLK环境管理物质技术标准"

| 工程变更通知单<br>ECN(DCN) NO. | 版本<br>REV | 日期<br>DATE | 说明<br>DESCRIPTION | 改变<br>CHANGE | 承认<br>APPRO. |
|-------------------------|-----------|------------|-------------------|--------------|--------------|
| KSECN19030              | A         | 20190618   | NEW RELEASE       | —            | —            |
| KSECN20021              | B         | 20200727   | 塑胶定位柱加胶, 依实物更新图画  | 覃智森          | 王永辉          |
| KSECN21013              | C         | 20210429   | 依客户要求修改马口铁尺寸与宏昌一致 | 蒋召           | 王晓东          |

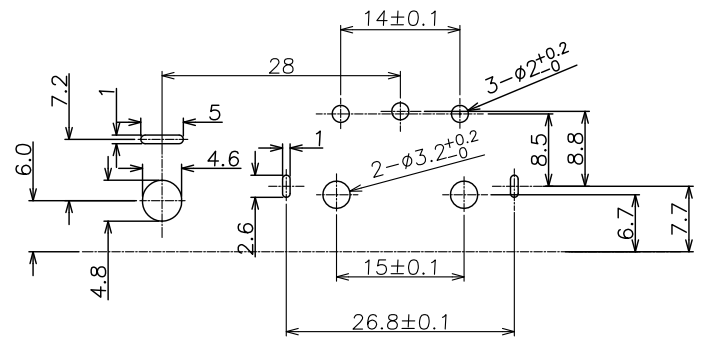
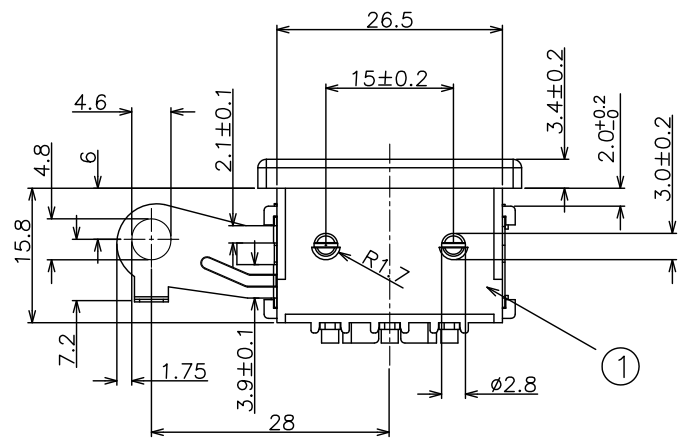
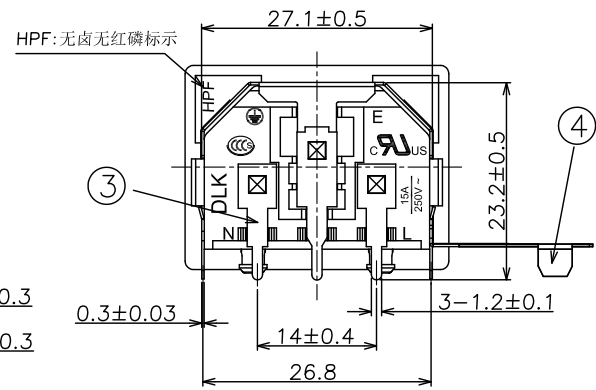
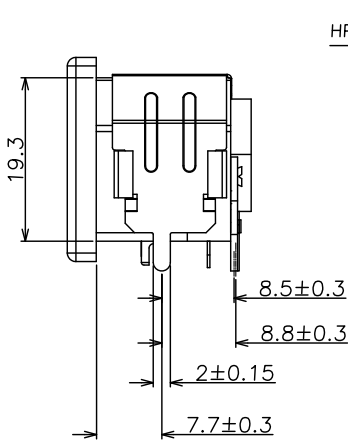
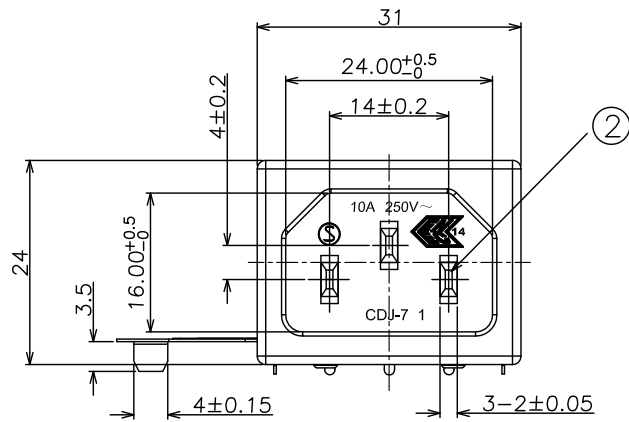

- NOTE:
- MATERIAL:
    - Housing: PA66 UL94v-0, color: Black
    - Contact: Copper alloy
    - Soldering Pin: Copper alloy
    - Soldering Pin: Ferro alloy
  - PLATING:
    - Contact: Nickel plated overall
    - Soldering Pin: Sn plated, Nickel underplated
  - MECHANICAL:
    - Mating force: 10~50N
    - Unmating force: 60N Max
    - Durability: 5000 cycles
  - ELECTRICAL:
    - Current Rating: 2.5/7A
    - Voltage Rating: 125/250V
    - Dielectric strength: 2000V AC FOR 1 minute
    - Insulation Resistance: 100MΩ Min.
    - Contact Resistance: 30mΩ Max
    - Operating Temperature: -55°C to +85°C
  - PACKING: Tray

RECOMMENDED PCB LAYOUT  
TOLERANCE: ±0.05mm

**DLK** 德力康电子科技有限公司  
DELIKANG ELECTRONICS TECHNOLOGY CO.,LTD

| NO. | ITEM          | Q'TY | DESCRIPTION         | FINISH |
|-----|---------------|------|---------------------|--------|
| 4   | Soldering Pin | 1    | Ferro alloy         | Tin    |
| 3   | Soldering Pin | 3    | Copper alloy        | Tin    |
| 2   | Contact Pin   | 3    | Copper alloy        | Nickel |
| 1   | Housing       | 1    | PA66 UL 94-V0 无卤无红磷 | Black  |

| GENERAL TOLERANCE<br>UNLESS OTHERWISE NOTED |       |
|---|-------|
| Angle                                       | ±5°   |
| X.  | ±0.35 |
| .X  | ±0.25 |
| .XX   | ±0.15 |
| .XXX  | ±0.10 |

|            |                       |           |             |
|------------|-----------------------|-----------|-------------|
| C 名称       | AC 90D 19H 左侧带接地导电片铁壳 |           |             |
| 档案名称       | C-ACT3K-30-HPF        | 料号        | 73K03B43303 |
| FILE NAME: |                       | PART NO.: |             |
| DRAWING    | 王永辉                   | CHECKED   | —           |
|            |                       | APPROVED  | 严成旺         |
| UNIT:      | mm                    | SCALE     | 1:1         |
|            |                       | SHEET:    | 1 of 1      |