

符合"DLK环境管理物质技术标准"

工程变更通知单 ECN(DCN) NO.	版本 REV	日期 DATE	说明 DESCRIPTION	改变 CHANGE	承认 APPRO.
ECN NO.07248	C	20070926	增加安规标志"RU"	刘三乐	严成胜
ECN NO.11085	D	20111116	扩大安规使用范围,取消数码A010197	刘三乐	李如均
KSECN14011	E	20140508	转昆山发行	王莉	严成胜

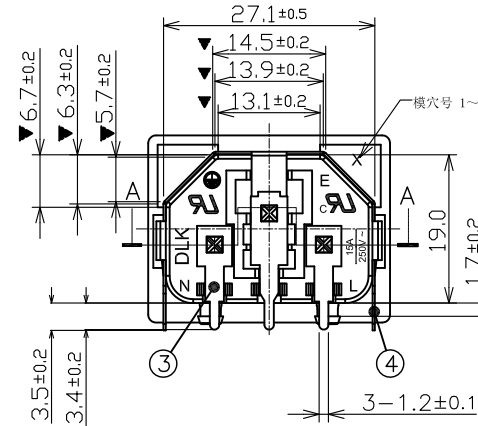
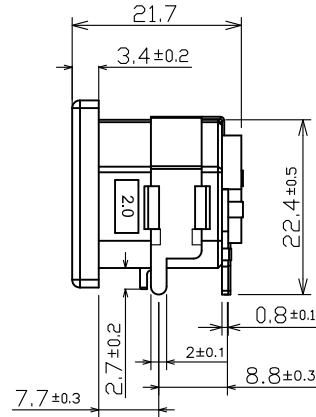
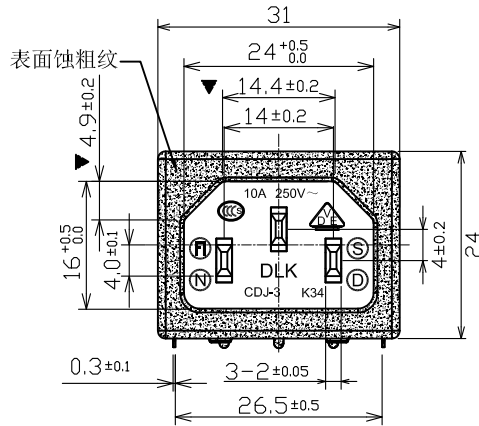

NOTE:

- MATERIAL:
 - Housing: PA66 UL94v-0, color: Black
 - Contact: Copper alloy
 - Soldering Pin: Copper alloy
 - Soldering Pin: Ferro alloy
- PLATING:
 - Contact: Nickel plated overall
 - Soldering Pin: Sn plated, Nickel underplated
- MECHANICAL:
 - Mating force: 10~50N
 - Unmating force: 60N Max
 - Durability: 5000 cycles
- ELECTRICAL:
 - Current Rating: 2.5/7A
 - Voltage Rating: 125/250V
 - Dielectric strength: 2000V AC FDR 1 minute
 - Insulation Resistance: 100MΩ Min.
 - Contact Resistance: 30mΩ Max
 - Operating Temperature: -55°C to +85°C
- PACKING: BOX

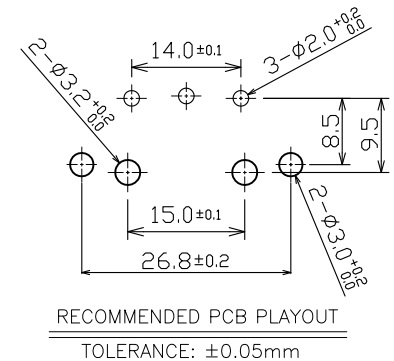
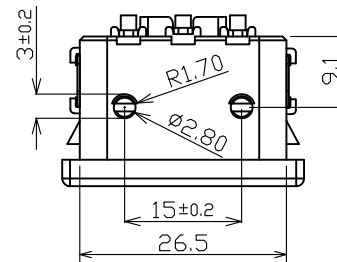
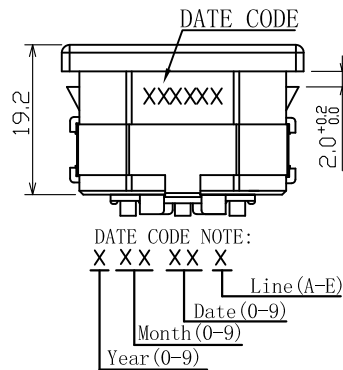
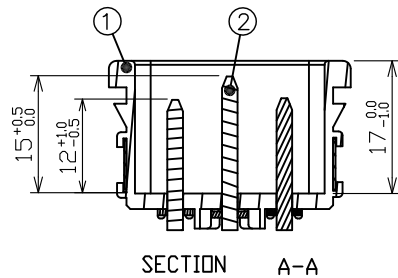

GENERAL TOLERANCE
UNLESS OTHERWISE NOTED

Angle	±5°
X.	±0.35
.X	±0.25
.XX	±0.15
.XXX	±0.10



德力康电子科技有限公司



DELIKANG ELECTRONICS TECHNOLOGY CO.,LTD

C 名称 TITLE:	CDJ-3K-3-B1			
档案名称 FILE NAME:	C-ACT3K-00-04	料号 PART NO.:	73K03B43040	
DRAWING	刘三乐	CHECKED	李如均	APPROVED 严成胜
UNIT:	mm	SCALE	1:1	SHEET: 1 of 1

NO.	ITEM	Q'TY	DESCRIPTION	FINISH
4	Soldering Pin	1	Ferro alloy	Tin
3	Soldering Pin	3	Copper alloy	Tin
2	Contact Pin	3	Copper alloy	Ni
1	INSULATOR	1	PA66 UL 94-V0	Black