

符合"DLK环境管理物质技术标准",符合HDMI协会规范要求

工程变更通知单 ECN(DCN) NO.	版本 REV	日期 DATE	说明 DESCRIPTION	改变 CHANGE	承认 APPRO.
KSECN18061	D	20181114	增加1U规格 \triangle *1	汪庆	王永辉
KSECN23030	E	20230926	依客户要求外壳脚长改为2.20mm \triangle *1	蒋召	段国强
KSECN24013	F	20240320	取消盘装“Y”包装方式 \triangle *1	蒋召	段国强

NOTE:

1. MATERIAL.

1.1 Housing: LCP UL94v-0, color: Black

1.2 Contact: Copper alloy

1.3 Shell: Copper alloy

1.4 Shrapnel: Stainless steel

2. PLATING:

2.1 Contact: 15u" Au plated on contact Area,
50u" Min. Matte Tin plated on solder tail,
50u" Min. Nickel underplated

2.2 Shell: Nickel plated overall

3. MECHANICAL:

3.1 Mating force: 4.5kgf Max.

3.2 Unmating force: 1.0~4.0kgf.

3.3 Durability: 10000 cycles Min.

4. ELECTRICAL:

4.1 Current Rating: 0.5A

4.2 Voltage Rating: 40V

4.3 Dielectric strength: 500V AC FOR 1 minute

4.4 Insulation Resistance: 100M Ω Min.

4.5 Contact Resistance: 10m Ω Max

5. Operating Temperature: -55°C to +105°C

6. PACKING: Tape & Reel

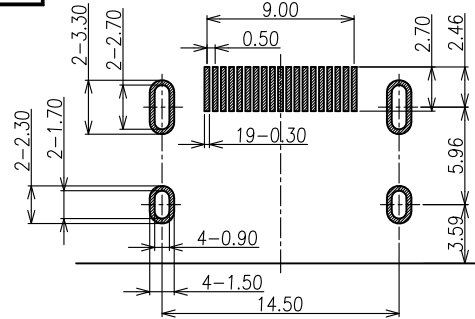
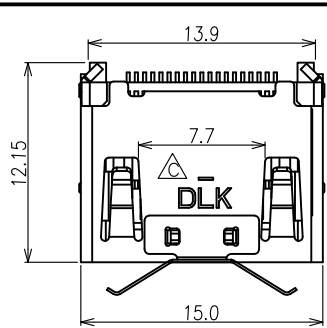

RECOMMENDED PCB LAYOUT
TOLERANCE: ± 0.05 mm

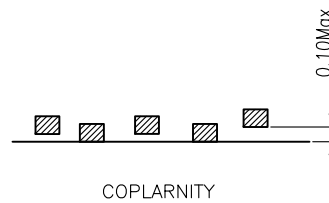
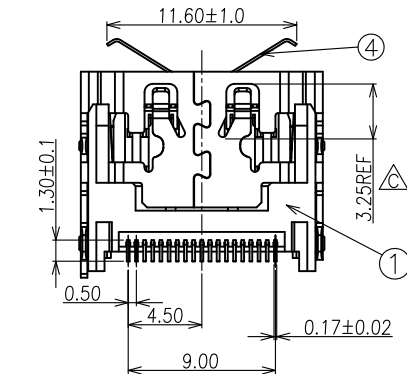
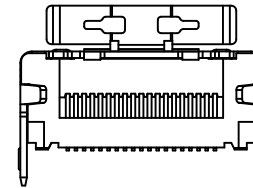
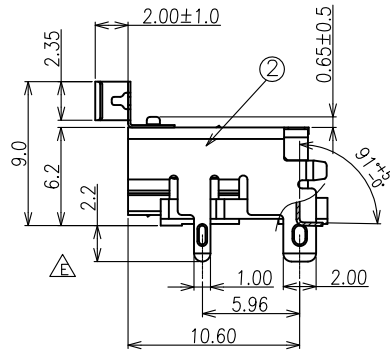
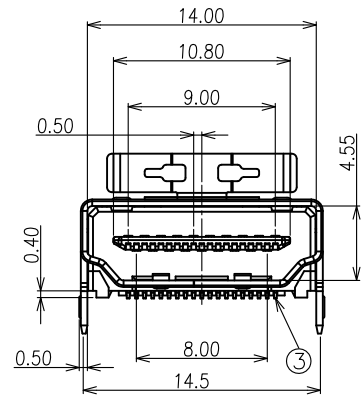

NO.	ITEM	Q'TY	DESCRIPTION	FINISH
4	SHRAPNEL	1	STAINLESS STEEL	—
3	CONTACT	19	COPPER ALLOY	PLATED Au
2	SHELL	1	COPPER ALLOY	PLATED Ni
1	HOUSING	1	LCP	UL94V-0, Black

GENERAL TOLERANCE
UNLESS OTHERWISE NOTED

Angle	$\pm 5'$
X.	± 0.35
.X	± 0.25
.XX	± 0.15
.XXX	± 0.10



德力康电子科技有限公司

DLK DELIKANG ELECTRONICS TECHNOLOGY CO.,LTD

C 名称 TITLE:	HDMI A/F R/A 9.0H 19PIN SMT CONN.			
档案名称 FILE NAME:	C-HDM41-00-05	料号 PART NO.:	54119B04151	
DRAWING	陆桂棚	CHECKED	APPROVED	严成旺
UNIT:	mm	SCALE	1:1	SHEET: 1 of 1