

符合DLK环境管理物质技术标准 符合HDMI协会规范

工程变更通知单 ECN(DCN) NO.	版本 REV	日期 DATE	说明 DESCRIPTION	改变 CHANGE	承认 APPRO.
KSECN22049	A	20221130	NEW RELEASE	—	—

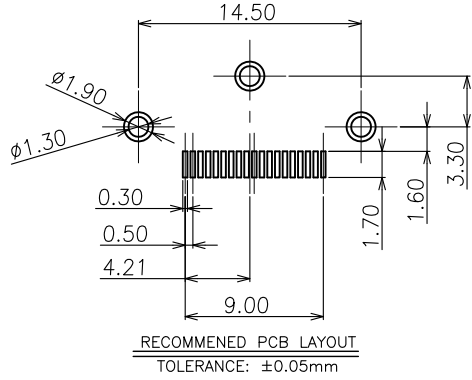

- NOTE:
- MATERIAL:
 - Housing: LCP UL94v-0, color: Black
 - Contact: Copper alloy
 - Shell: Stainless steel
 - PLATING:
 - Contact: 1u" Au plated on contact Area, 50u" Min. Matte Tin plated on solder tail, 50u" Min. Nickel underplated
 - Shell: Nickel plated overall
 - MECHANICAL:
 - Mating force: 4.5kgf Max.
 - Unmating force: 1.0~4.0kgf.
 - Durability: 10000 cycles Min.
 - ELECTRICAL:
 - Current Rating: 0.5A
 - Voltage Rating: 40V
 - Dielectric strength: 500V AC FOR 1 minute
 - Insulation Resistance: 100MΩ Min.
 - Contact Resistance: 10mΩ Max
 - Operating Temperature: -55°C to +105°C
 - PACKING: Tape & Reel

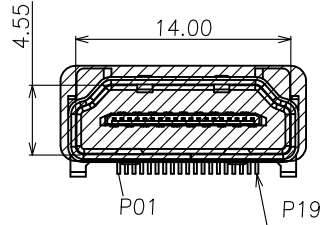
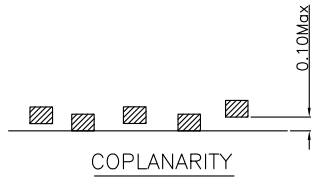
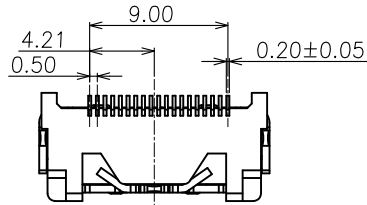
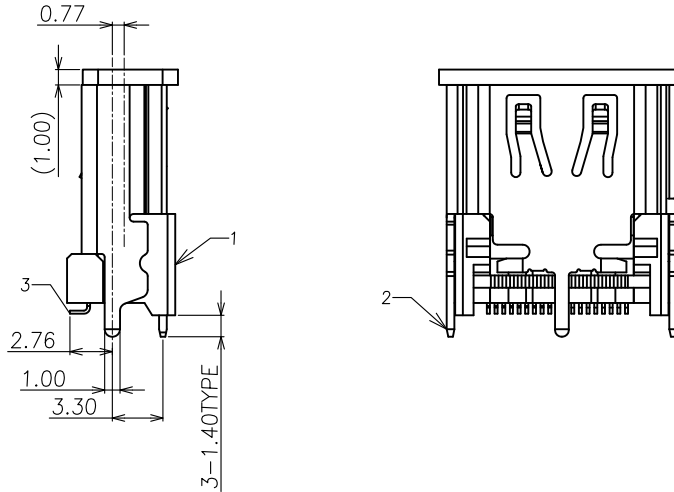
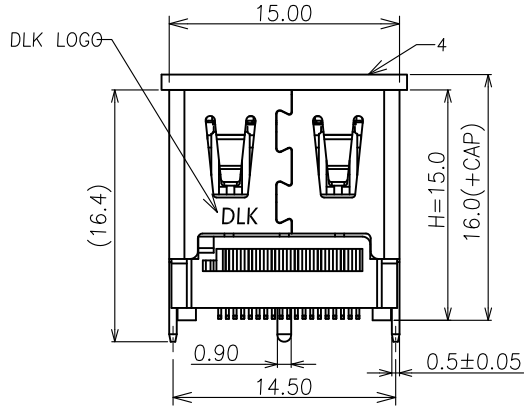

4	CAP	1	LCP	UL94V-0,Black
3	CONTACT	19	Copper alloy	See P/N
2	SHELL	1	Stainless steel	PLATED NI 30u" min
1	HOUSING	1	LCP	UL94V-0,Black
NO.	ITEM	Q'TY	DESCRIPTION	FINISH

GENERAL TOLERANCE
UNLESS OTHERWISE NOTED

Angle	±5'
X.	±0.35
.X	±0.25
.XX	±0.15
.XXX	±0.10

德力康电子科技有限公司
DLK DELIKANG ELECTRONICS TECHNOLOGY CO.,LTD

C 名称 TITLE:	HDMI A/F V/T 15.0H 19Pin 端子镀金1u"脚长1.4			
档案名称 FILE NAME:	C-HDM2A-00-02	料号 PART NO:	52A19B01121	
DRAWING	蒋召	CHECKED	覃智森	APPROVED 吴豪
UNIT:	mm	SCALE	1:1	SHEET: 1 of 1