

符合DLK环境管理物质技术标准 符合HDMI协会规范

工程变更通知单 ECN(DCN) NO.	版本 REV	日期 DATE	说明 DESCRIPTION	改变 CHANGE	承认 APPRO.
KSECN21059	A	20211111	NEW RELEASE	—	—

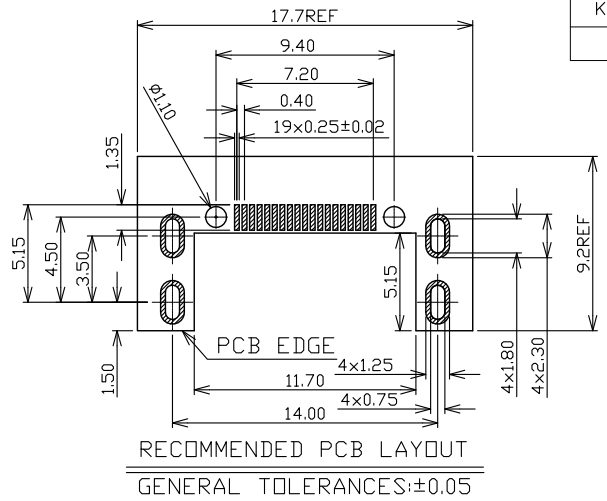
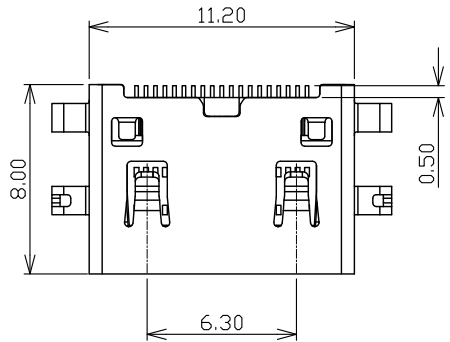

NOTE:

- MATERIAL:
 - Housing: LCP UL94v-0, color: Black
 - Contact: Copper alloy
 - Shell: Copper alloy
- PLATING:
 - Contact: 1u"Au plated on contact Area, 50u" Min. Matte Tin plated on solder tail, 50u" Min. Nickel underplated
 - Shell: Nickel plated overall
- MECHANICAL:
 - Mating force: 4.5kgf Max.
 - Unmating force: 1.0~4.0kgf.
 - Durability: 10000 cycles Min.
- ELECTRICAL:
 - Current Rating: 0.5A
 - Voltage Rating: 40V
 - Dielectric strength: 500V AC FOR 1 minute
 - Insulation Resistance: 100MΩ Min.
 - Contact Resistance: 10mΩ Max
- PACKING: Tape & Reel

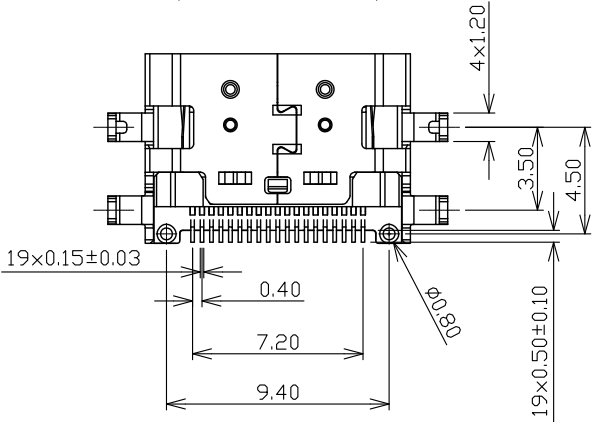
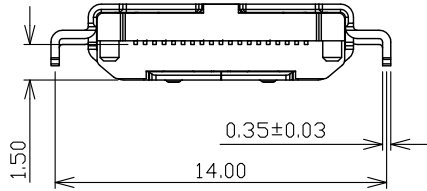
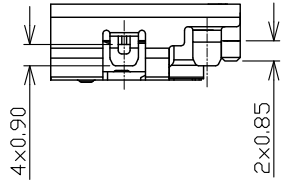
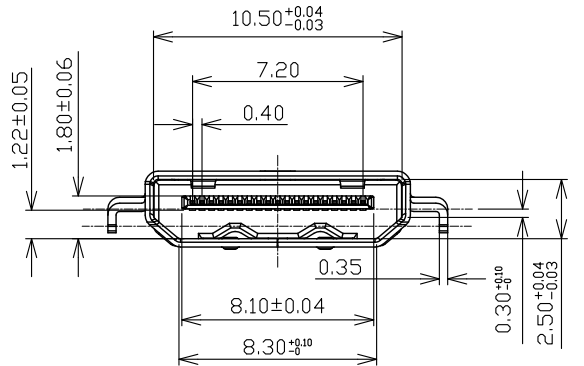

DLK 德力康电子科技有限公司
DLK DELIKANG ELECTRONICS TECHNOLOGY CO.,LTD

GENERAL TOLERANCE UNLESS OTHERWISE NOTED	
Angle	±5'
X.	±0.35
.X	±0.25
.XX	±0.15
.XXX	±0.10

C	名称 TITLE:	HDMI C FEMALE SMT 沉板 H1.50			
	档案名称 FILE NAME.	C-HDM88-00-00	料号 PART NO.	58819B01101	
	DRAWING	蒋召	CHECKED	覃智森	APPROVED 吴豪
	UNIT:	mm	SCALE	1:1	SHEET: 1 of 1

3	SHELL	1	COPPER ALLOY	PLATED Ni
2	HOUSING	1	LCP	UL94V-0, BLACK
1	CONTACT	19	COPPER ALLOY	PLATED Au
NO.	ITEM	Q'TY	DESCRIPTION	FINISH