

符合"DLK环境管理物质技术标准",符合HDMI协会规范要求

工程变更通知单 ECN(DCN) NO.	版本 REV	日期 DATE	说明 DESCRIPTION	改变 CHANGE	承认 APPRO.
KSECN11134	B	20111020	修改定位柱大小	郭孝振	严成旺
KSECN16002	C	20151225	改为MOLDING结构	陈浩泽	严成旺
KSECN20019	D	20200511	锁孔扭力规格由3.5kgf改为4.5kgf min (搭配0.5mm厚垫片)锁孔后不能有滑牙变形现象 \triangle *1	王永辉	严成旺

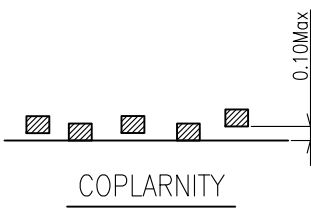
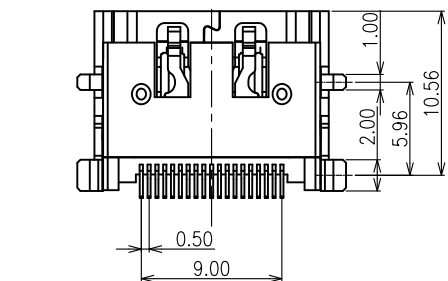
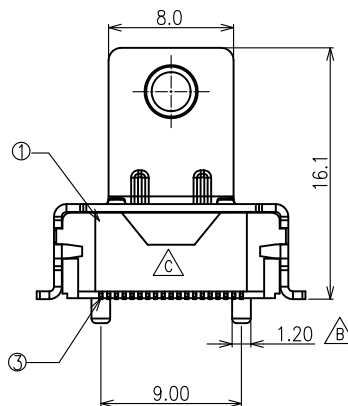
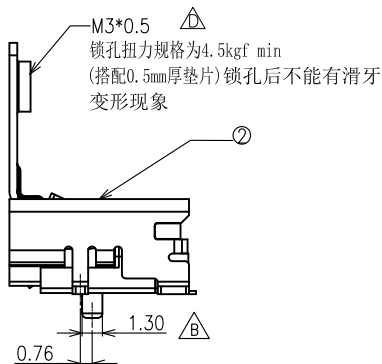
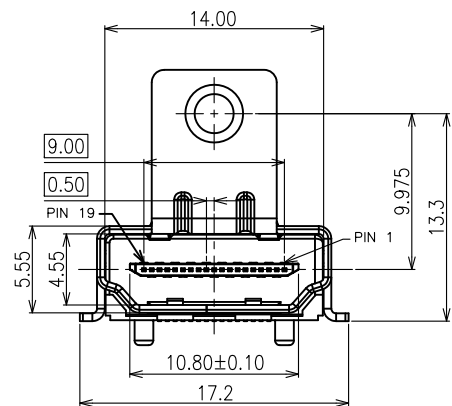
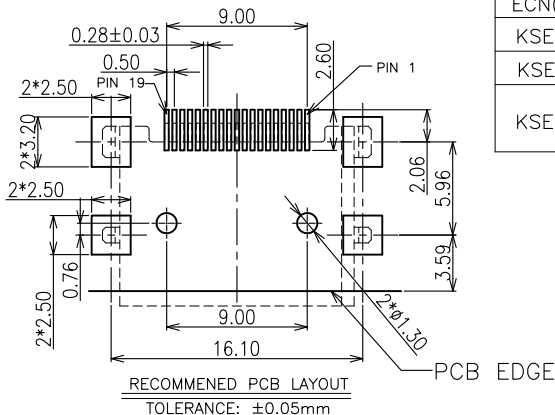
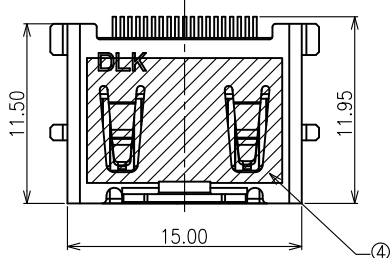

NOTE:

1. MATERIAL:

1.1 Housing: LCP UL94v-0, color: Black

1.2 Contact: Copper alloy

1.3 Shell: Copper alloy

2. PLATING:

2.1 Contact: 15u"Au plated on contact Area,
50u" Min. Matte Tin plated on solder tail,
50u" Min. Nickel underplated

2.2 Shell: Nickel plated overall

3. MECHANICAL:

3.1 Mating force:4.5kgf Max.

3.2 Unmating force:1.0~4.0kgf.

3.3 Durability:10000 cycles Min.

4 ELECTRICAL:

4.1 Current Rating:0.5A

4.2 Voltage Rating:40V

4.3 Dielectric strength:500V AC FOR 1 minute

4.4 Insulation Resistance:100MΩ Min.

4.5 Contact Resistance:10mΩ Max

5. Operating Temperature:-55°c to +105°c

6. PACKING: Tape & Reel

NO.	ITEM	Q'TY	DESCRIPTION	FINISH
4	MYLAR	1	MYLAR	
3	CONTACT	19	COPPER ALLOY	PLATED Au
2	SHELL	1	COPPER ALLOY	PLATED NI
1	HOUSING	1	LCP	UL94V-0,Black

GENERAL TOLERANCE
UNLESS OTHERWISE NOTED

Angle	±5°
X.	±0.35
.X	±0.25
.XX	±0.15
.XXX	±0.10
A4	

德力康电子科技有限公司
DELIKANG ELECTRONICS TECHNOLOGY CO.,LTD

C 名称 TITLE:	HDMI 19PIN REC. CONN.		
档案名称 FILE NAME:	C-HDM2T-00-05	料号 PART NO.:	52T19B04151
DRAWING	郭孝振	CHECKED	APPROVED 严成旺
UNIT:	mm	SCALE	1:1
			SHEET: 1 of 1