

IST8306

3D Magnetometer

Datasheet

Table of Contents

1. GENERAL DESCRIPTION	3
2. BLOCK DIAGRAM, PACKAGE DIMENSION AND APPLICATION CIRCUIT	4
2.1. Block Diagram.....	4
2.2. Package Dimensions and Magnetic Field Directions	4
2.3. Marking Information.....	5
2.4. Pin Configurations and Functions	5
2.5. Application Circuit	6
3. ELECTRICAL SPECIFICATIONS.....	7
3.1. Absolute Maximum Ratings.....	7
3.2. Recommended Operating Conditions	7
3.3. Electrical Specifications.....	8
3.4. Magnetic Sensor Specifications.....	9
3.5. Power On Reset (POR) Specifications	9
4. TECHNOLOGY OVERVIEW	10
4.1. AMR Technology.....	10
4.2. High Reliability Monolithic Design.....	10
4.3. Ultra-low Hysteresis Design.....	10
4.4. Magnetic Setting Mechanism.....	10
5. ORDERING INFORMATION.....	11
6. LEGAL DISCLAIMER	11
6.1. Warranty and Liability Disclaimer	11
6.2. Application Disclaimer	11
6.3. Disclaimer Regarding Changes	11

1. General Description

iSentek IST8306 is a 3-axis digital magnetometer with $0.8 \times 0.8 \times 0.53 \text{ mm}^3$, 4-pin WLCSP-BGA package. It is an integrated chip with 3-axis magnetic sensors, digital control logic, a built-in temperature compensation circuit and self-test function. IST8306 provides an I²C digital output with fast mode up to 400 kHz. The high output data rate, ultra-low noise, ultra-low hysteresis and excellent output stability over working temperature range make it a perfect product for high accuracy applications.

Features

- Monolithic 3-axis magnetic sensor
- Ultra-compact package size of $0.8 \times 0.8 \times 0.53 \text{ mm}^3$, 4-pin WLCSP-BGA package
- I²C slave, Fast Mode up to 400 kHz
- Wide dynamic range of $\pm 3000 \mu\text{T}$ for each axis
- Maximum 200Hz output data rate
- Ultra-low hysteresis ($\sim 0.1 \text{ \%FS}$)
- Low suspend current of 0.5uA
- Wide operating temperature range
- High precision temperature compensation
- Built-in self-test function
- Built-in noise suppression filter
- Software and algorithm support are available (for tilt compensation and soft/hard iron calibration)
- RoHS, HF and TSCA compliant

Applications

- Quadcopter/Drone Applications
- Augmented Reality Applications
- Virtual Reality Applications
- Location Based Services
- Navigation Applications
- Industrial Applications
- Magnetometry
- IoT devices
- Heading
- Gaming

2. Block Diagram, Package Dimension and Application Circuit

2.1. Block Diagram

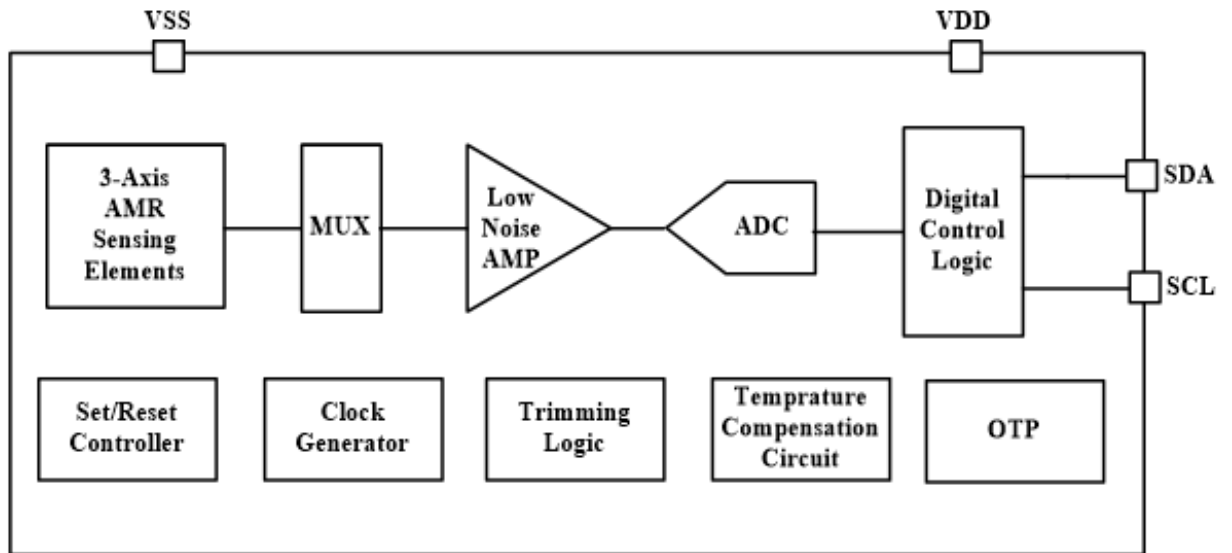

Figure 1. Block Diagram

2.2. Package Dimensions and Magnetic Field Directions

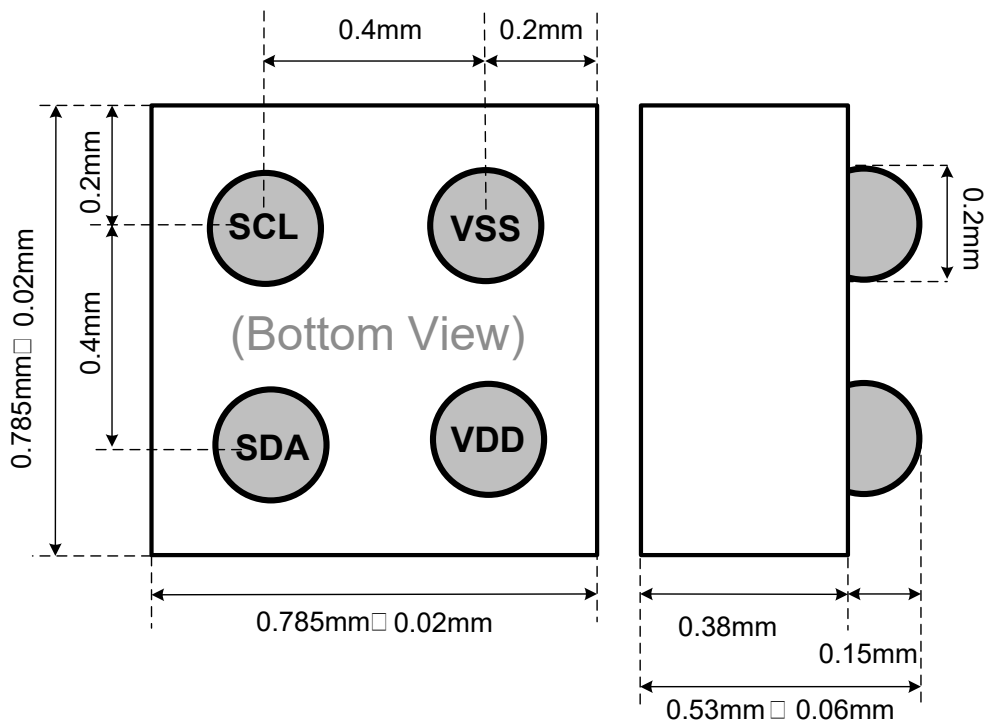

Figure 2. Package Dimensions

IST8306 3D TOP View

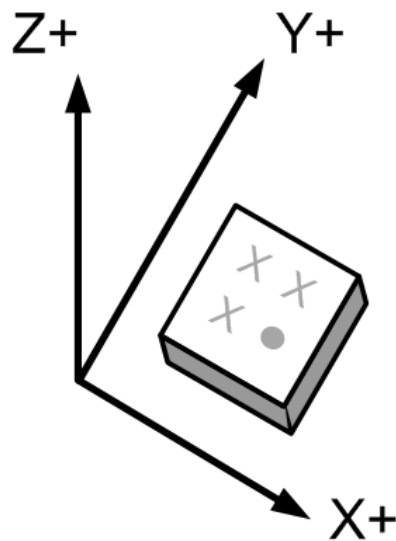
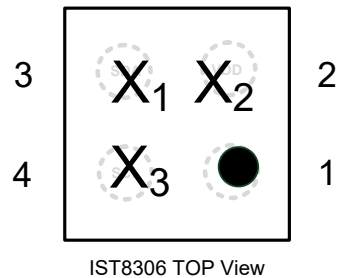

Figure 3. Magnetic Field Directions

2.3. Marking Information

Date code X₁X₂
 Product code X₃●

X₁: Year
 X₂: Week
 X₃: Product code



IST8306 TOP View

2.4. Pin Configurations and Functions

Pin No	Pin Name	I/O type	Function
1	VSS	Supply	Ground
2	VDD	Supply	Power supply voltage, 1.65 ~ 1.95 V
3	SDA	I/O	I ² C data
4	SCL	I	I ² C clock

2.5. Application Circuit

The application circuits for the IST8306 sensor are depicted in *Figure 4* and *Figure 5*, showing standard and alternative configurations to accommodate different space constraints.

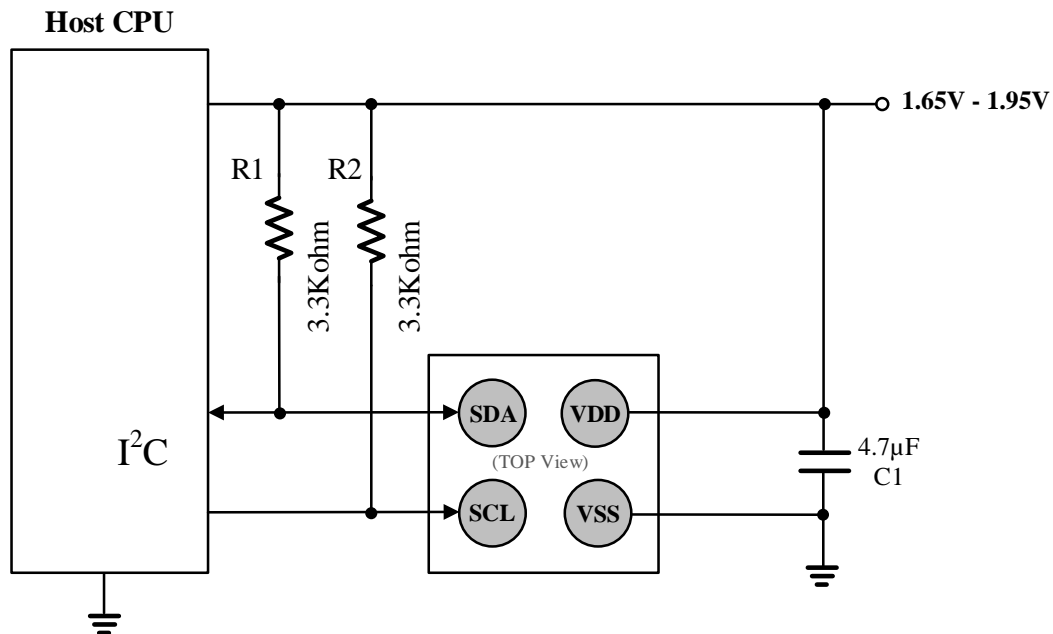

Figure 4. Application Circuit

Note: This setup is ideal for applications with sufficient space to accommodate the 4.7 μF capacitor.

For applications where space is limited, the application circuit can be modified as follows:

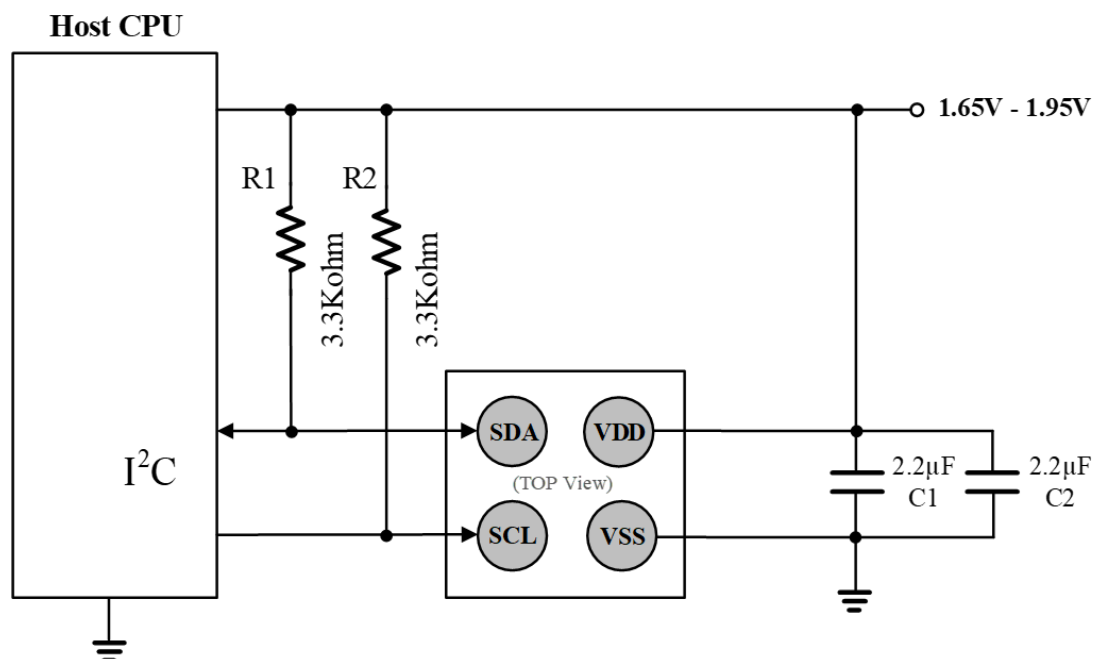

Figure 5. Alternative Application Circuit

Note: Two 2.2 μF capacitors (size 0201) in parallel replace the single 4.7 μF capacitor.

3. Electrical Specifications

3.1. Absolute Maximum Ratings

Parameter	Symbol	Limits	Unit
Storage Temperature	TSTG	-40 to +125	°C
Supply Voltage	VDD	-0.3 to +1.98	V
Electrostatic Discharge Voltage* ¹	VESD_HBM	-4000 to 4000	V
Electrostatic Discharge Voltage* ²	VESD_MM	-400 to 400	V
Electrostatic Discharge Voltage* ³	VESD_CDM	-800 to 800	V
Reflow Classification	JESD22-A113 with 260 °C Peak Temperature		

1. Human Body Model (HBM)
2. Machine Model (MM)
3. Charge Device Model (CDM)

3.2. Recommended Operating Conditions

Parameter	Symbol	Min.	Typ.	Max.	Unit
Operating Temperature	TA	-20		+85	°C
Supply Voltage	VDD	1.65	1.8	1.95	V

3.3. Electrical Specifications

(Operating conditions: TA = +25 °C; VDD = 1.8 V; 4.7 μF ceramic capacitors tied to between VDD & VSS pin with maximum allowed line width and 5mm distance.)

Parameter	Symbol	Conditions	Min.	Typ.	Max	Unit
Operating Current	IDD3A	with OSR* ¹ =32 setting, 10 sps 50 sps 100 sps		0.25 1.2 2.3		mA
Suspend Current	ISPD			0.5		uA
Standby Mode Current	ISBM			8		uA
Output Data Rate (ODR)	ODR			200* ²		Hz
Input Low Voltage	VIL		0		VDD *30%	V
Input High Voltage	VIH		VDD *70%		VDD	V
Output Low Voltage	VOL	IOL = +4 mA	0		VDD *20%	V
Output High Voltage	VOH	IOH = -100 uA (Except SCL and SDA)	VDD *80%		VDD	V

1. Register OSRCNTL(0x41) controls OSR setting.

2. 200 Hz ODR can be achieved with OSR ≤ 16.

3.4. Magnetic Sensor Specifications

(Operating conditions: TA = +25°C; VDD = 1.8 V; 4.7 μF ceramic capacitors tied to between VDD & VSS pin with maximum allowed line width and 5mm distance.)

Parameter	Condition	Min.	Typ.	Max	Unit
Dynamic Range (Each Axis)	Total Applied Field		±3000		uT
Linearity	±200 uT Range		0.1		%FS
	±3000 uT Range		1.5		
Resolution			0.3		uT/LSB
Sensitivity			3.3		LSB/uT
Hysteresis			0.1		%FS
RMS Noise			0.8		uT

3.5. Power On Reset (POR) Specifications

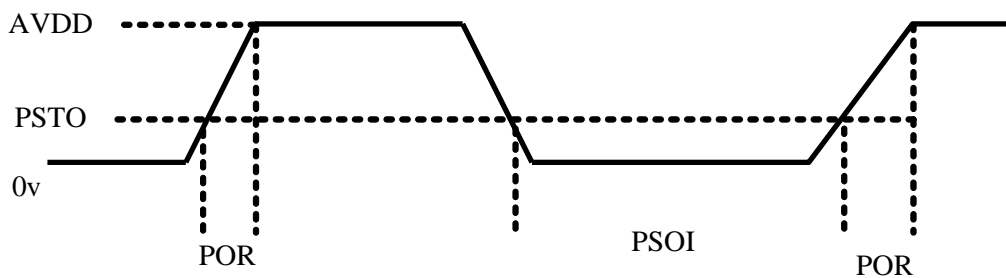

PSTO: Power Supply Turn Off voltage
 PSOI: Power Supply Turn Off Interval
 POR: Power On Reset

PSTO: max=0.7volt
 PSOI: min=10ms
 POR: max:50ms

When POR circuit detects the rise of VDD voltage, it resets all internal circuits and initializes all registers. After reset, IST8306 transits to Standby mode.

4. Technology Overview

4.1. AMR Technology

IST8306, an iSentek patented magnetometer is designed based on Anisotropy Magnetoresistance (AMR) technology. The output is generated from the resistance change of the AMR resistors as external magnetic field varies. The sensitivity is approximately 50 to 200 times greater than conventional Hall elements. The high sensitivity allows a higher output data rate (ODR), lower noise, and lower power consumption.

4.2. High Reliability Monolithic Design

IST8306 consists of full AMR Wheatstone Bridges detecting magnetic components in three orthogonal directions. The monolithic packaging of IST8306 enables outstanding stability to thermal shock and ultra-small footprint, making it a highly efficient and robust device.

4.3. Ultra-low Hysteresis Design

The ultra-low hysteresis design of IST8306 prevents the magnetometer from experiencing dynamic offset after encountering a strong external magnetic field impact. Practically, the angular accuracy is restored automatically after the removal of magnetic interference. This feature of IST8306 minimizes the requirement for user calibration, providing a much better user experience as compared to conventional products like Hall sensors, which need frequent calibration to ensure required precision.

4.4. Magnetic Setting Mechanism

AMR sensing resistors consist of high permalloy thin film and metallization. Because AMR resistors are made of soft magnetic material, irreversible magnetic rotation may occur after experiencing a strong external magnetic field, resulting in angular error induced by the residual magnetization in the sensitive direction. To solve this issue, a magnetic setting mechanism was introduced in IST8306. A magnetic field is generated within IST8306 to align the magnetization of AMR sensing resistors before every measurement. This auto-zeroing mechanism ensures the stability of the IST8306's angular accuracy throughout the operation.

5. Ordering Information

Order Number	Package Type	Packaging	Marking Information
IST8306	WLCSP – 4 pin	Tape and Reel: 5k pieces per reel	X ₁ X ₂ X ₃ ● X ₁ : Last number of the year X ₂ : Week number X ₃ : Product code

For more information on iSentek’s magnetic sensors, please send an email to sales@isentek.com or visit our website at www.isentek.com.

The sensing technology of IST8306 is protected by US Patent 9,970,997, CN Patent CN106125020A.

6. Legal Disclaimer

6.1. Warranty and Liability Disclaimer

iSentek Inc. warrants the information in this datasheet. It is assumed that the specification is accurate and reliable. However, iSentek Inc. makes no warranties or claims regarding the accuracy or completeness of this information and takes no responsibility for the use of the information, nor does it convey any license under its patent rights or the rights of third parties. iSentek Inc. shall not be liable for any consequential, incidental, indirect, or punitive damages (including, but not limited to, profit loss, business interruption, and further expenses related to the removal, replacement, or rework of any products).

6.2. Application Disclaimer

iSentek's products are unsuitable for life-critical and safety-critical applications. For the use of its products in such applications, iSentek disclaims all liability. The customer agrees to indemnify and hold iSentek harmless from and against all liabilities and losses.

6.3. Disclaimer Regarding Changes

iSentek reserves the right to modify the contents of this datasheet, including specifications and descriptions, at any time and without prior notice. This document supersedes all previously issued information.