



WINSTAR Display Co.,Ltd.
華凌光電股份有限公司



Winstar Display Co., LTD

華凌光電股份有限公司

WEB: <https://www.winstar.com.tw> E-mail: sales@winstar.com.tw



SPECIFICATION

CUSTOMER : _____

MODULE NO.: WH2002AR-TMI-JT#

APPROVED BY: (FOR CUSTOMER USE ONLY)	PCB VERSION:	DATA:
--	---------------------	--------------

SALES BY	APPROVED BY	CHECKED BY	PREPARED BY

VERSION	DATE	REVISED PAGE NO.	SUMMARY
0	2023/12/28		First issue

MODLE NO :

RECORDS OF REVISION**DOC. FIRST ISSUE**

VERSION	DATE	REVISED PAGE NO.	SUMMARY
0	2023/12/28		First issue

Contents

- 1.Module Classification Information
- 2.Precautions in use of LCD Modules
- 3.General Specification
- 4.Absolute Maximum Ratings
- 5.Electrical Characteristics
- 6.Optical Characteristics
- 7.Interface Pin Function
- 8.Contour Drawing
- 9.Character Generator ROM Pattern
- 10.Reliability
- 11.Backlight Information
- 12.Inspection specification
- 13.Material List of Components for RoHs
- 14.Recommendable Storage
- 15.Communication Information

1.Module Classification Information

W H 2002 AR — T M I — JT#
 ① ② ③ ④ ⑤ ⑥ ⑦ ⑧

① Brand : WINSTAR DISPLAY CORPORATION

② Display Type : H→Character Type, G→Graphic Type, T→TAB Type

③ Display Font : Character 20 words, 02 Lines.

④ Model serials no.

⑤ Backlight N→Without backlight T→LED, White L→LED, Full color
 Type : B→EL, Blue green A→LED, Amber J→DIP LED,Blue
 D→EL, Green R→LED, Red K→DIP LED,White
 W→EL, White O→LED, Orange E→DIP LED, Yellow Green
 M→EL, Yellow Green G→LED, Green H→DIP LED,Amber
 F→CCFL, White P→LED, Blue I→DIP LED, Red
 Y→LED, Yellow Green X→LED, Dual color
 G→LED, Green C→LED, Full color

⑥ LCD Mode : B→TN Positive, Gray V→FSTN Negative, Blue
 N→TN Negative, T→FSTN Negative, Black
 L→VA Negative D→FSTN Negative (Double film)
 H→ HTN Positive, Gray F→FSTN Positive
 I→HTN Negative, Black K→FSC Negative
 U→HTN Negative, Blue S→FSC Positive
 M→STN Negative, Blue E→ISTN Negative, Black
 G→STN Positive, Gray C→CSTN Negative, Black
 Y→STN Positive, Yellow Green A→ASTN Negative, Black

⑦ LCD Polarizer A→Reflective, N.T, 6:00 H→Transflective, W.T,6:00
 Type/ D→Reflective, N.T, 12:00 K→Transflective, W.T,12:00
 Temperature G→Reflective, W. T, 6:00 C→Transmissive, N.T,6:00
 range/ View J→Reflective, W. T, 12:00 F→Transmissive, N.T,12:00
 direction B→Transflective, N.T,6:00 I→Transmissive, W. T, 6:00
 E→Transflective, N.T.12:00 L→Transmissive, W.T,12:00

⑧ Special Code JT:English and Japanese standard font
 #:Fit in with the ROHS Directions and regulations

2.Precautions in use of LCD Modules

- (1) Avoid applying excessive shocks to the module or making any alterations or modifications to it.
- (2) Don't make extra holes on the printed circuit board, modify its shape or change the components of LCD module.
- (3) Don't disassemble the LCM.
- (4) Don't operate it above the absolute maximum rating.
- (5) Don't drop, bend or twist LCM.
- (6) Soldering: only to the I/O terminals.
- (7) Storage: please storage in anti-static electricity container and clean environment.
- (8) Winstar have the right to change the passive components, including R3,R6 & backlight adjust resistors. (Resistors,capacitors and other passive components will have different appearance and color caused by the different supplier.)
- (9) Winstar have the right to change the PCB Rev. (In order to satisfy the supplying stability, management optimization and the best product performance...etc, under the premise of not affecting the electrical characteristics and external dimensions, Winstar have the right to modify the version.)
- (10) To ensure the stability of the display screen, please apply screen saver after showing 30 mins of fixed display content.
- (11) Please heat up a little the tape sticking on the components when removing it; otherwise the components might be damaged.

3.General Specification

Item	Dimension	Unit
Number of Characters	20 characters x 2Lines	—
Module dimension	116.0 x 37.0 x 13.9 (MAX)	mm
View area	85.0 x 18.6	mm
Active area	73.5x 11.5	mm
Dot size	0.60 x 0.65	mm
Dot pitch	0.65 x 0.70	mm
Character size	3.20 x 5.55	mm
Character pitch	3.70 x 5.95	mm
LCD type	STN Negative, Blue Transmissive (In LCD production, It will occur slightly color difference. We can only guarantee the same color in the same batch.)	
Duty	1/16	
View direction	6 o'clock	
Backlight Type	LED, White	
Controller IC	ST7066	
Interface	UART	

4. Absolute Maximum Ratings

Item	Symbol	Min	Typ	Max	Unit
Operating Temperature	T _{OP}	-20	—	+70	°C
Storage Temperature	T _{ST}	-30	—	+80	°C
Supply Voltage	—	V _{SS} -0.3	—	6.0	V
EEPROM Cell Endurance	—	100K	—	—	E/W
Input Voltage	—	V _{SS} -0.3	—	V _{DD} +0.3	V

*Note: "E/W" means Erase/Write times

5. Electrical Characteristics

Item	Symbol	Condition	Min	Typ	Max	Unit
Supply Voltage For Logic	V_{DD-VSS}	—	4.5	5.0	5.5	V
Supply Voltage For LCD	V_{DD-V_O}	Ta=25°C	4.2	4.35	4.5	V
Input High Voltage	V_{IH}	—	3.5	—	5.0	V
Input Low Voltage	V_{IL}	—	0	—	1.5	V
Supply Current (Module + Backlight) *Note	I_{DD}	$V_{DD}=5.0V$	—	—	45	mA

*Note : Backlight 100% turn on.

*Software functionally adjusts LCD contrast.

6. Optical Characteristics

Item	Symbol	Condition	Min	Typ	Max	Unit
View Angle	θ	$CR \geq 2$	0	—	20	$\phi = 180^\circ$
	θ	$CR \geq 2$	0	—	40	$\phi = 0^\circ$
	θ	$CR \geq 2$	0	—	30	$\phi = 90^\circ$
	θ	$CR \geq 2$	0	—	30	$\phi = 270^\circ$
Contrast Ratio	CR	—	—	3	—	—
Response Time	T rise	—	—	150	200	ms
	T fall	—	—	150	200	ms

Definition of Operation Voltage (Vop)

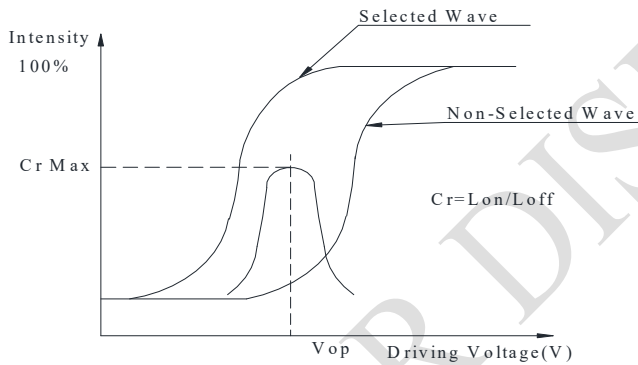
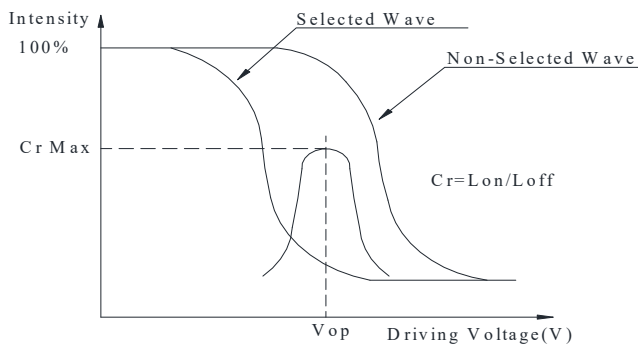

Definition of Response Time (Tr, Tf)

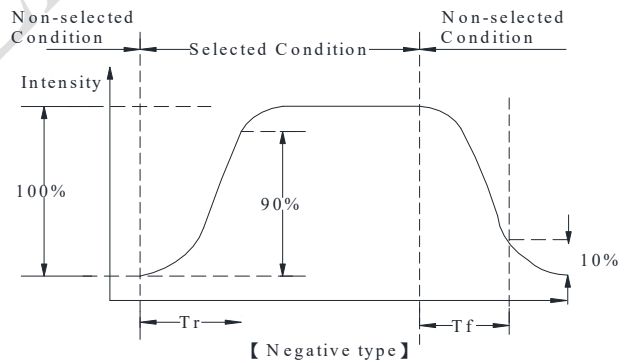
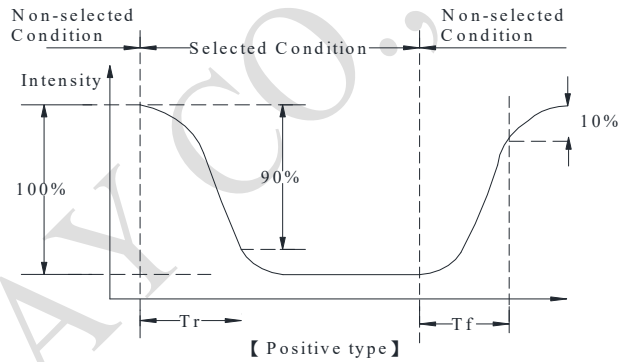

Conditions :

Operating Voltage : Vop Viewing Angle (θ , ϕ) : 0° , 0°
 Frame Frequency : 64 HZ Driving Waveform : 1/N duty, 1/a bias

Definition of viewing angle ($CR \geq 2$)

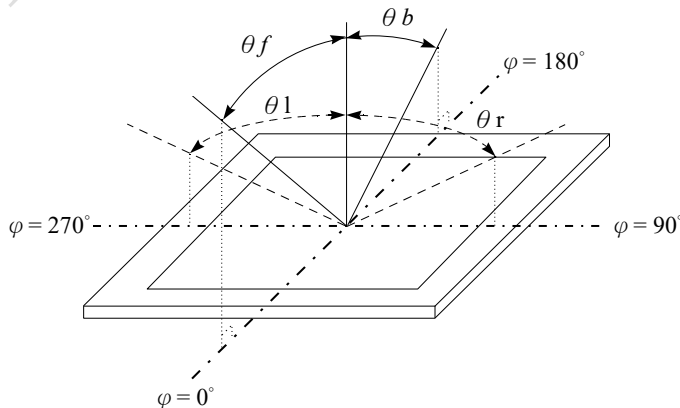

7.Interface Pin Function

CON1

Pin No.	Symbol	Description
1	RX	UART: serial data input (full duplex communication)
2	VSS	Ground
3	VDD	Supply Voltage
4	TX	UART: serial data output
5	CS	SPI: chip select
6	SDO	SPI: serial data output
7	SCK/SCL	SPI: serial clock I2C: serial clock
8	SDI/SDA	SPI: serial data input I2C: serial data input/output
9	VSS	Ground
10	VDD	Supply Voltage
11-14	NC	No connection

8. Contour Drawing

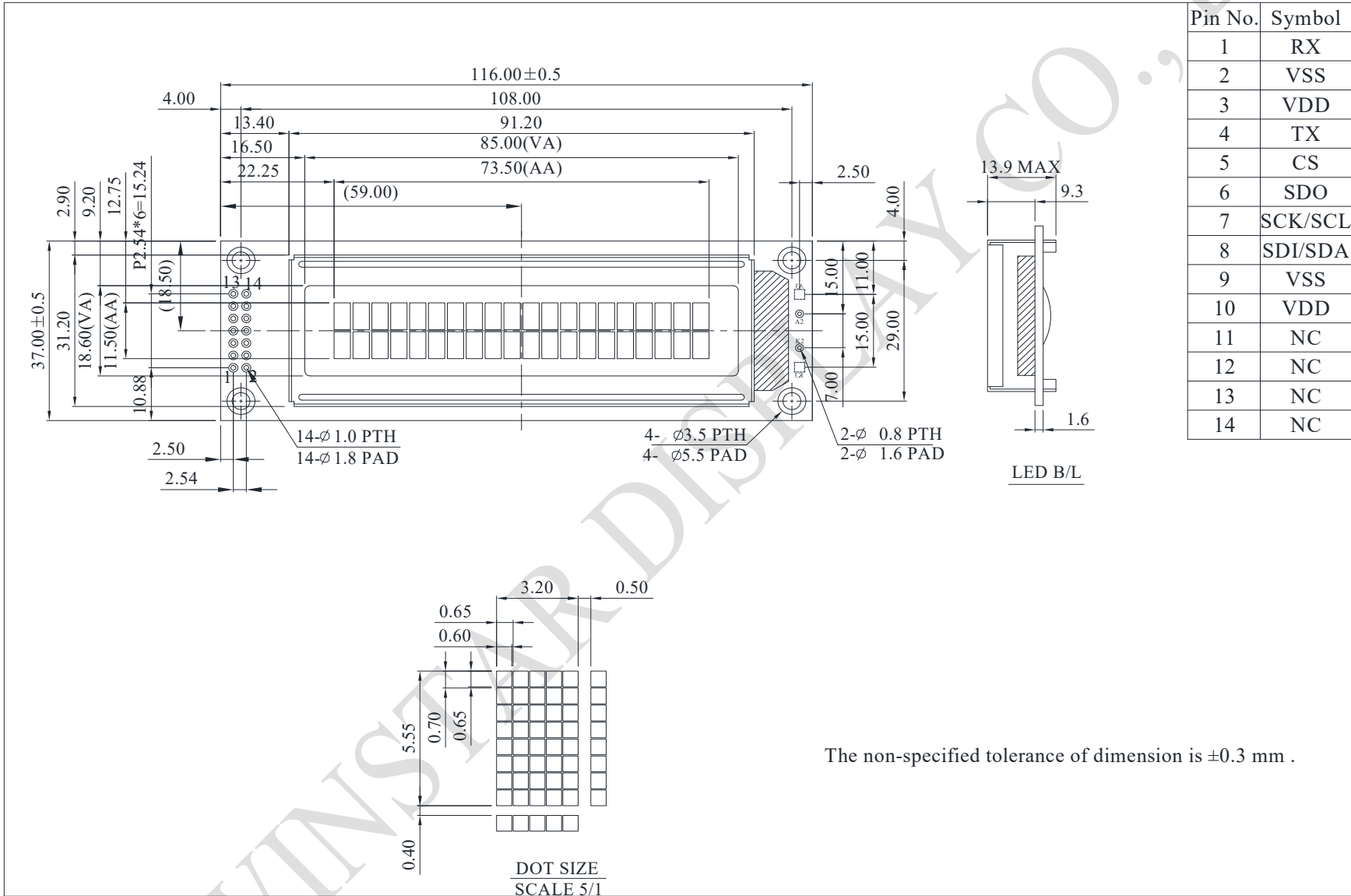

Pin No.	Symbol
1	RX
2	VSS
3	VDD
4	TX
5	CS
6	SDO
7	SCK/SCL
8	SDI/SDA
9	VSS
10	VDD
11	NC
12	NC
13	NC
14	NC

The non-specified tolerance of dimension is ± 0.3 mm .

9.Character Generator ROM Pattern

Table.2

Upper 4 bit Lower 4 bit	LLLL	LLLH	LLHL	LLHH	LHLL	LHLH	LHHL	LHHH	HLLL	HLLH	HLHL	HLHH	HHLL	HHLH	HHHL	HHHH
LLLL	CG RAM (1)			0	1	2	3	4				5	6	7	8	9
LLLH	(2)	.	!	1	2	3	4	5			6	7	8	9	0	1
LLHL	(3)	"	2	3	4	5	6	7			8	9	0	1	2	3
LLHH	(4)	*	3	4	5	6	7	8			9	0	1	2	3	4
LHLL	(5)	\$	4	5	6	7	8	9			0	1	2	3	4	5
LHLH	(6)	%	5	6	7	8	9	0			1	2	3	4	5	6
LHHL	(7)	&	6	7	8	9	0	1			2	3	4	5	6	7
LHHH	(8)	'	7	8	9	0	1	2			3	4	5	6	7	8
HLLL	(1)	(8	9	0	1	2	3			4	5	6	7	8	9
HLLH	(2))	9	0	1	2	3	4			5	6	7	8	9	0
HLHL	(3)	*	0	1	2	3	4	5			6	7	8	9	0	1
HLHH	(4)	+	1	2	3	4	5	6			7	8	9	0	1	2
HHLL	(5)	,	2	3	4	5	6	7			8	9	0	1	2	3
HHLH	(6)	-	3	4	5	6	7	8			9	0	1	2	3	4
HHHL	(7)	.	4	5	6	7	8	9			0	1	2	3	4	5
HHHH	(8)	/	5	6	7	8	9	0			1	2	3	4	5	6

10. Reliability

Content of Reliability Test (Wide temperature, -20°C~70°C)

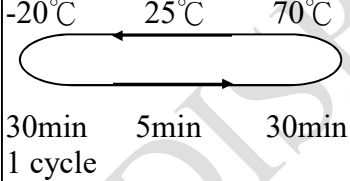
Environmental Test			
Test Item	Content of Test	Test Condition	Note
High Temperature storage	Endurance test applying the high storage temperature for a long time.	80°C 200hrs	2
Low Temperature storage	Endurance test applying the low storage temperature for a long time.	-30°C 200hrs	1,2
High Temperature Operation	Endurance test applying the electric stress (Voltage & Current) and the thermal stress to the element for a long time.	70°C 200hrs	— —
Low Temperature Operation	Endurance test applying the electric stress under low temperature for a long time.	-20°C 200hrs	1
High Temperature/Humidity storage	The module should be allowed to stand at 60°C, 90%RH max For 96hrs under no-load condition excluding the polarizer, Then taking it out and drying it at normal temperature.	60°C, 90%RH 96hrs	1,2
Thermal shock resistance	The sample should be allowed stand the following 10 cycles of operation  30min 5min 30min 1 cycle	-20°C/70°C 10 cycles	— —
Vibration test	Endurance test applying the vibration during transportation and using.	Total fixed amplitude : 1.5mm Vibration Frequency : 10~55Hz One cycle 60 seconds to 3 directions of X,Y,Z for Each 15 minutes	3
Static electricity test	Endurance test applying the electric stress to the terminal.	VS=±600V(contact), ±800v(air), RS=330Ω CS=150pF 10 times	— —

Note1: No dew condensation to be observed.

Note2: The function test shall be conducted after 4 hours storage at the normal Temperature and humidity after remove from the test chamber.

Note3: The packing have to including into the vibration testing.

11.Backlight Information

Specification

Parameter	Symbol	Min	Typ	Max	Unit	Test Condition
Luminance (Without LCD)	IV	360	450	—	cd/m²	(Note 1)
LED Life Time (For Reference only)	—	—	50K	—	Hr.	25°C,50-60%RH, (Note 2)
Color	White					

Note 1: Software functionally adjusts backlight luminance

Note 2:50K hours is only an estimate for reference.

12. Inspection specification

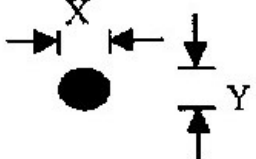
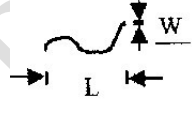
No	Item	Criterion	AQL												
01	Electrical Testing	Missing vertical, horizontal segment, segment contrast defect. Missing character , dot or icon. Display malfunction. No function or no display. Current consumption exceeds product specifications. LCD viewing angle defect. Mixed product types. Contrast defect.	0.65												
02	Black or white spots on LCD (display only)	2.1 White and black spots on display $\leq 0.25\text{mm}$, no more than three white or black spots present. 2.2 Densely spaced: No more than two spots or lines within 3mm	2.5												
03	LCD black spots, white spots, contamination (non-display)	3.1 Round type : As following drawing $\Phi = (x + y) / 2$  <table border="1" data-bbox="821 974 1348 1243"> <thead> <tr> <th>Size</th> <th>Acceptable QTY</th> </tr> </thead> <tbody> <tr> <td>$\Phi \leq 0.10$</td> <td>Accept no dense</td> </tr> <tr> <td>$0.10 < \Phi \leq 0.20$</td> <td>2</td> </tr> <tr> <td>$0.20 < \Phi \leq 0.25$</td> <td>1</td> </tr> <tr> <td>$0.25 < \Phi$</td> <td>0</td> </tr> </tbody> </table>	Size	Acceptable QTY	$\Phi \leq 0.10$	Accept no dense	$0.10 < \Phi \leq 0.20$	2	$0.20 < \Phi \leq 0.25$	1	$0.25 < \Phi$	0	2.5		
		Size	Acceptable QTY												
$\Phi \leq 0.10$	Accept no dense														
$0.10 < \Phi \leq 0.20$	2														
$0.20 < \Phi \leq 0.25$	1														
$0.25 < \Phi$	0														
3.2 Line type : (As following drawing)  <table border="1" data-bbox="710 1299 1348 1556"> <thead> <tr> <th>Length</th> <th>Width</th> <th>Acceptable QTY</th> </tr> </thead> <tbody> <tr> <td>---</td> <td>$W \leq 0.02$</td> <td>Accept no dense</td> </tr> <tr> <td>$L \leq 3.0$</td> <td>$0.02 < W \leq 0.03$</td> <td rowspan="2">2</td> </tr> <tr> <td>$L \leq 2.5$</td> <td>$0.03 < W \leq 0.05$</td> </tr> <tr> <td>---</td> <td>$0.05 < W$</td> <td>As round type</td> </tr> </tbody> </table>	Length	Width	Acceptable QTY	---	$W \leq 0.02$	Accept no dense	$L \leq 3.0$	$0.02 < W \leq 0.03$	2	$L \leq 2.5$	$0.03 < W \leq 0.05$	---	$0.05 < W$	As round type	2.5
Length	Width	Acceptable QTY													
---	$W \leq 0.02$	Accept no dense													
$L \leq 3.0$	$0.02 < W \leq 0.03$	2													
$L \leq 2.5$	$0.03 < W \leq 0.05$														
---	$0.05 < W$	As round type													
04	Polarizer bubbles	If bubbles are visible, judge using black spot specifications, not easy to find, must check in specify direction. <table border="1" data-bbox="821 1601 1348 1904"> <thead> <tr> <th>Size Φ</th> <th>Acceptable QTY</th> </tr> </thead> <tbody> <tr> <td>$\Phi \leq 0.20$</td> <td>Accept no dense</td> </tr> <tr> <td>$0.20 < \Phi \leq 0.50$</td> <td>3</td> </tr> <tr> <td>$0.50 < \Phi \leq 1.00$</td> <td>2</td> </tr> <tr> <td>$1.00 < \Phi$</td> <td>0</td> </tr> <tr> <td>Total QTY</td> <td>3</td> </tr> </tbody> </table>	Size Φ	Acceptable QTY	$\Phi \leq 0.20$	Accept no dense	$0.20 < \Phi \leq 0.50$	3	$0.50 < \Phi \leq 1.00$	2	$1.00 < \Phi$	0	Total QTY	3	2.5
Size Φ	Acceptable QTY														
$\Phi \leq 0.20$	Accept no dense														
$0.20 < \Phi \leq 0.50$	3														
$0.50 < \Phi \leq 1.00$	2														
$1.00 < \Phi$	0														
Total QTY	3														

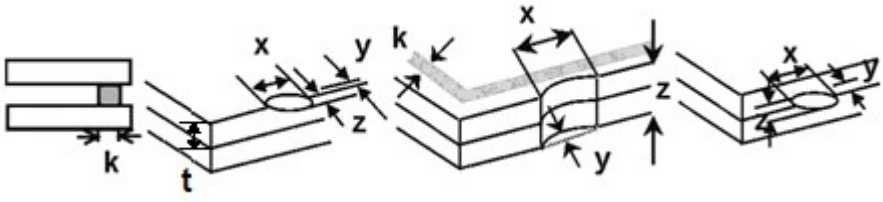
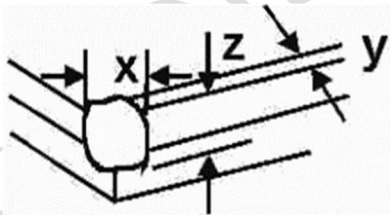
No	Item	Criterion	AQL																		
05	Scratches	Follow NO.3 LCD black spots, white spots, contamination																			
06	Chipped glass	<p>Symbols Define: x: Chip length y: Chip width z: Chip thickness k: Seal width t: Glass thickness a: LCD side length L: Electrode pad length:</p> <p>6.1 General glass chip : 6.1.1 Chip on panel surface and crack between panels:</p>  <table border="1" data-bbox="454 884 1364 1086"> <thead> <tr> <th>z: Chip thickness</th> <th>y: Chip width</th> <th>x: Chip length</th> </tr> </thead> <tbody> <tr> <td>$Z \leq 1/2t$</td> <td>Not over viewing area</td> <td>$x \leq 1/8a$</td> </tr> <tr> <td>$1/2t < z \leq 2t$</td> <td>Not exceed 1/3k</td> <td>$x \leq 1/8a$</td> </tr> </tbody> </table> <p>⊙ If there are 2 or more chips, x is total length of each chip.</p> <p>6.1.2 Corner crack:</p>  <table border="1" data-bbox="454 1523 1364 1736"> <thead> <tr> <th>z: Chip thickness</th> <th>y: Chip width</th> <th>x: Chip length</th> </tr> </thead> <tbody> <tr> <td>$Z \leq 1/2t$</td> <td>Not over viewing area</td> <td>$x \leq 1/8a$</td> </tr> <tr> <td>$1/2t < z \leq 2t$</td> <td>Not exceed 1/3k</td> <td>$x \leq 1/8a$</td> </tr> </tbody> </table> <p>⊙ If there are 2 or more chips, x is the total length of each chip.</p>	z: Chip thickness	y: Chip width	x: Chip length	$Z \leq 1/2t$	Not over viewing area	$x \leq 1/8a$	$1/2t < z \leq 2t$	Not exceed 1/3k	$x \leq 1/8a$	z: Chip thickness	y: Chip width	x: Chip length	$Z \leq 1/2t$	Not over viewing area	$x \leq 1/8a$	$1/2t < z \leq 2t$	Not exceed 1/3k	$x \leq 1/8a$	2.5
z: Chip thickness	y: Chip width	x: Chip length																			
$Z \leq 1/2t$	Not over viewing area	$x \leq 1/8a$																			
$1/2t < z \leq 2t$	Not exceed 1/3k	$x \leq 1/8a$																			
z: Chip thickness	y: Chip width	x: Chip length																			
$Z \leq 1/2t$	Not over viewing area	$x \leq 1/8a$																			
$1/2t < z \leq 2t$	Not exceed 1/3k	$x \leq 1/8a$																			

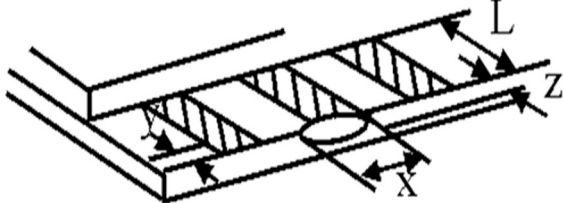
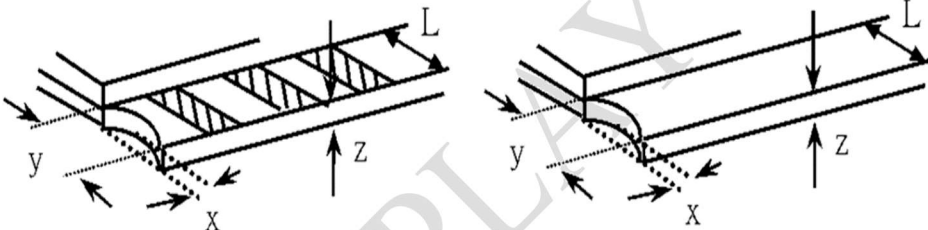
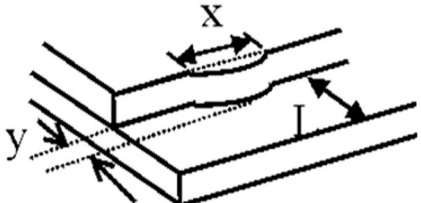
No	Item	Criterion	AQL																
06	Glass crack	<p>Symbols :</p> <p>x: Chip length y: Chip width z: Chip thickness k: Seal width t: Glass thickness a: LCD side length L: Electrode pad length</p> <p>6.2 Protrusion over terminal :</p> <p>6.2.1 Chip on electrode pad :</p>  <table border="1" data-bbox="368 728 1294 835"> <thead> <tr> <th>y: Chip width</th> <th>x: Chip length</th> <th>z: Chip thickness</th> </tr> </thead> <tbody> <tr> <td>$y \leq 0.5\text{mm}$</td> <td>$x \leq 1/8a$</td> <td>$0 < z \leq t$</td> </tr> </tbody> </table> <p>6.2.2 Non-conductive portion:</p>  <table border="1" data-bbox="368 1126 1294 1234"> <thead> <tr> <th>y: Chip width</th> <th>x: Chip length</th> <th>z: Chip thickness</th> </tr> </thead> <tbody> <tr> <td>$y \leq L$</td> <td>$x \leq 1/8a$</td> <td>$0 < z \leq t$</td> </tr> </tbody> </table> <p>⊙If the chipped area touches the ITO terminal, over 2/3 of the ITO must remain and be inspected according to electrode terminal specifications. ⊙If the product will be heat sealed by the customer, the alignment mark not be damaged.</p> <p>6.2.3 Substrate protuberance and internal crack.</p> <table border="1" data-bbox="778 1496 1342 1603"> <thead> <tr> <th>y: width</th> <th>x: length</th> </tr> </thead> <tbody> <tr> <td>$y \leq 1/3L$</td> <td>$x \leq a$</td> </tr> </tbody> </table> 	y: Chip width	x: Chip length	z: Chip thickness	$y \leq 0.5\text{mm}$	$x \leq 1/8a$	$0 < z \leq t$	y: Chip width	x: Chip length	z: Chip thickness	$y \leq L$	$x \leq 1/8a$	$0 < z \leq t$	y: width	x: length	$y \leq 1/3L$	$x \leq a$	2.5
y: Chip width	x: Chip length	z: Chip thickness																	
$y \leq 0.5\text{mm}$	$x \leq 1/8a$	$0 < z \leq t$																	
y: Chip width	x: Chip length	z: Chip thickness																	
$y \leq L$	$x \leq 1/8a$	$0 < z \leq t$																	
y: width	x: length																		
$y \leq 1/3L$	$x \leq a$																		

No	Item	Criterion	AQL
07	Cracked glass	The LCD with extensive crack is not acceptable.	2.5
08	Backlight elements	8.1 Illumination source flickers when lit. 8.2 Spots or scratched that appear when lit must be judged. Using LCD spot, lines and contamination standards. 8.3 Backlight doesn't light or color wrong.	0.65 2.5 0.65
09	Bezel	9.1 Bezel may not have rust, be deformed or have fingerprints, stains or other contamination. 9.2 Bezel must comply with job specifications.	2.5 0.65
10	PCB、COB	10.1 COB seal may not have pinholes larger than 0.2mm or contamination. 10.2 COB seal surface may not have pinholes through to the IC. 10.3 The height of the COB should not exceed the height indicated in the assembly diagram. 10.4 There may not be more than 2mm of sealant outside the seal area on the PCB. And there should be no more than three places. 10.5 No oxidation or contamination PCB terminals. 10.6 Parts on PCB must be the same as on the production characteristic chart. There should be no wrong parts, missing parts or excess parts. 10.7 The jumper on the PCB should conform to the product characteristic chart. 10.8 If solder gets on bezel tab pads, LED pad, zebra pad or screw hold pad, make sure it is smoothed down. 10.9 The Scraping testing standard for Copper Coating of PCB  $X * Y \leq 2\text{mm}^2$	2.5 2.5 0.65 2.5 2.5 0.65 0.65 2.5 2.5
11	Soldering	11.1 No un-melted solder paste may be present on the PCB. 11.2 No cold solder joints, missing solder connections, oxidation or icicle. 11.3 No residue or solder balls on PCB. 11.4 No short circuits in components on PCB.	2.5 2.5 2.5 0.65

NO	Item	Criterion	AQL
12	General appearance	12.1 No oxidation, contamination, curves or, bends on interface Pin (OLB) of TCP.	2.5
		12.2 No cracks on interface pin (OLB) of TCP.	0.65
		12.3 No contamination, solder residue or solder balls on product.	2.5
		12.4 The IC on the TCP may not be damaged, circuits.	2.5
		12.5 The uppermost edge of the protective strip on the interface pin must be present or look as if it cause the interface pin to sever.	2.5
		12.6 The residual rosin or tin oil of soldering (component or chip component) is not burned into brown or black color.	2.5
		12.7 Sealant on top of the ITO circuit has not hardened.	2.5
		12.8 Pin type must match type in specification sheet.	0.65
		12.9 LCD pin loose or missing pins.	0.65
		12.10 Product packaging must the same as specified on packaging specification sheet.	0.65
		12.11 Product dimension and structure must conform to product specification sheet.	0.65
		12.12 Visual defect outside of VA is not considered to be rejection.	0.65

13. Material List of Components for RoHs

1. WINSTAR Display Co., Ltd hereby declares that all of or part of products (with the mark “#”in code), including, but not limited to, the LCM, accessories or packages, manufactured and/or delivered to your company (including your subsidiaries and affiliated company) directly or indirectly by our company (including our subsidiaries or affiliated companies) do not intentionally contain any of the substances listed in all applicable EU directives and regulations, including the following substances.

Exhibit A : The Harmful Material List

Material	Cd	Pb	Hg	Cr6+	PBB	PBDE	DEHP	BBP	DBP	DIBP
Limited Value	100 ppm	1000 ppm	1000 ppm	1000 ppm	1000 ppm	1000 ppm	1000 ppm	1000 ppm	1000 ppm	1000 ppm
Above limited value is set up according to RoHS.										

2. Process for RoHS requirement : (only for RoHS inspection)

- (1) Use the Sn/Ag/Cu soldering surface ; the surface of Pb-free solder is rougher than we used before.
- (2) Heat-resistance temp. :
 - Reflow : 250°C, 30 seconds Max. ;
 - Connector soldering wave or hand soldering : 320°C, 10 seconds max.
- (3) Temp. curve of reflow, max. Temp. : 235±5°C ;
 - Recommended customer’s soldering temp. of connector : 280°C, 3 seconds.

14.Recommendable Storage

1. Place the panel or module in the temperature $25^{\circ}\text{C}\pm 5^{\circ}\text{C}$ and the humidity below 65% RH
2. Do not place the module near organics solvents or corrosive gases.
3. Do not crush, shake, or jolt the module.

15. Communication Information

This module has a built-in MCU for serial communication. It provides UART, SPI, and I2C communication protocols. Additionally, the built-in MCU requires a 180ms time upon power-up to initialize the module.

1. UART protocol

To enter UART Mode, place jumpers on both JB0 and JB1.

Communication format is 8-bit data, no parity, 1 stop bit and no handshaking.

The default baud rate of UART is 9600bps, and it supports five different baud rates: 4800, 9600, 14400, 19200, and 57600 bps.

The default baud rate can be restored if Self-Test mode is selected.

UART format is follows:

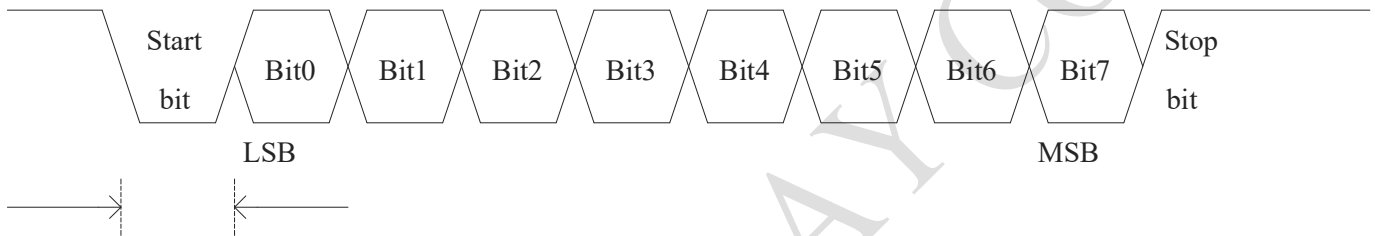

- When the Baud Rate is 4800bps, the width of each bit is 1/4800 seconds.
- When the Baud Rate is 9600bps, the width of each bit is 1/9600 seconds.
- When the Baud Rate is 14400bps, the width of each bit is 1/14400 seconds.
- When the Baud Rate is 19200bps, the width of each bit is 1/19200 seconds.
- When the Baud Rate is 57600bps, the width of each bit is 1/57600 seconds

2. SPI protocol

To enter SPI Mode, keep JB0 open and place a jumper on JB1.

The SPI interface allows for receiving data at a clock rate of up to 100KHz.

SPI mode has a normally high level idle clock. When the Chip Select line (CS) is low, data is sampled on the rising edge of the Serial Clock line (SCK).

SPI format is follows:

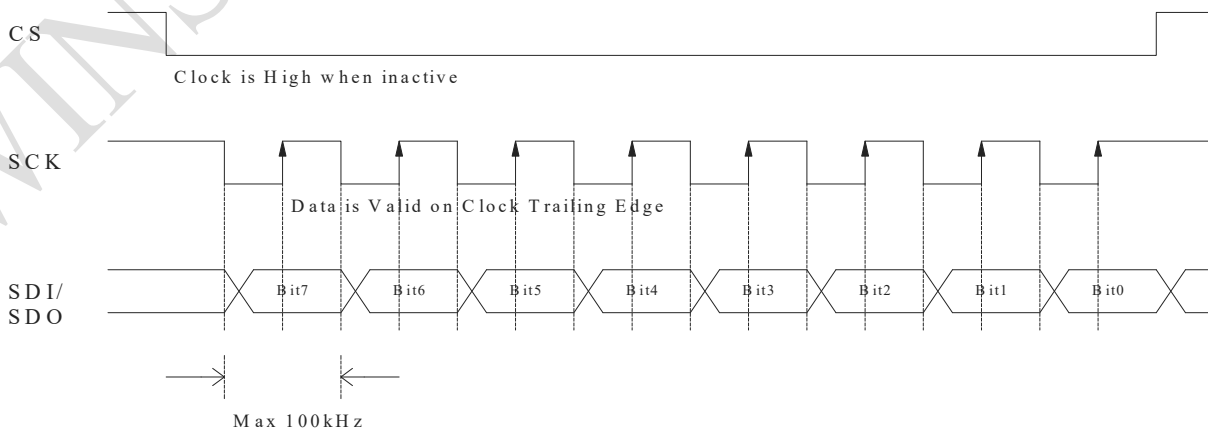

WINSTAR DISPLAY CO., LTD

3. I2C protocol

To enter I2C Mode, place a jumper on JB0 and keep JB1 open.

The I2C interface allows for receiving data at a clock rate of up to 100KHz.

The default I2C address is set to 0xA0 (with Read/Wirte bit).

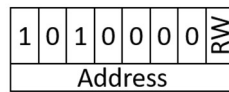

Users have the option to modify this address using the "Change I2C Slave Address" command, but the address value must be an even number (LSB = 0).

The default I2C address can be restored if Self-Test mode is selected.

I2C format is follows:

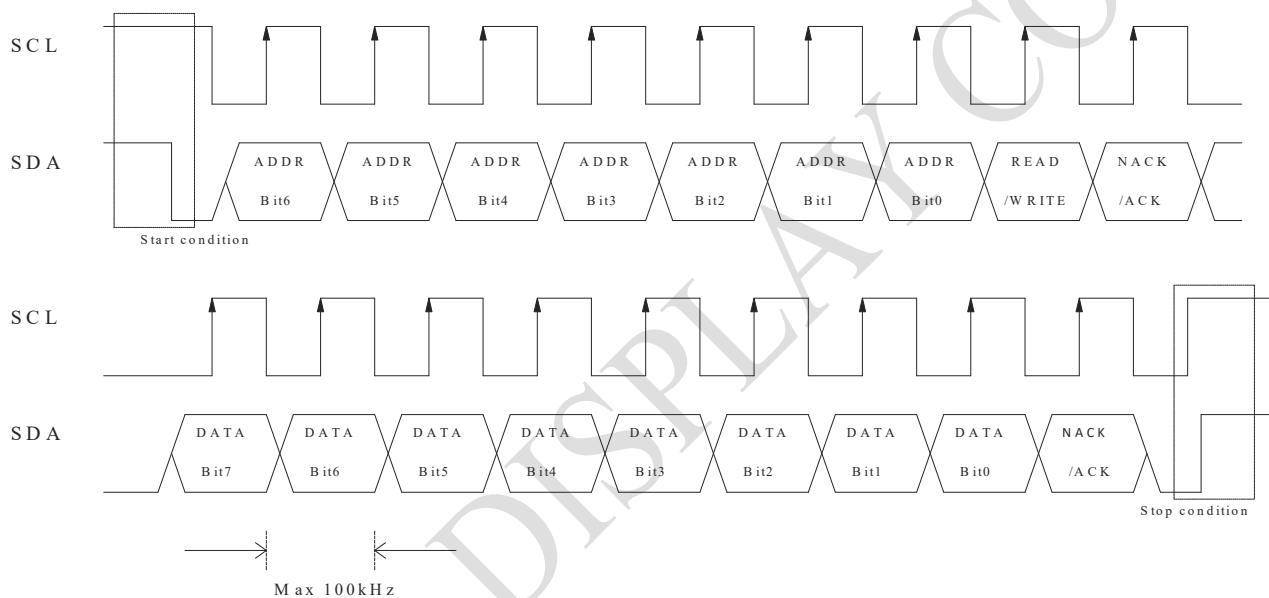

When sending the "Display On" command, it can be done in the following ways:

Method 1:

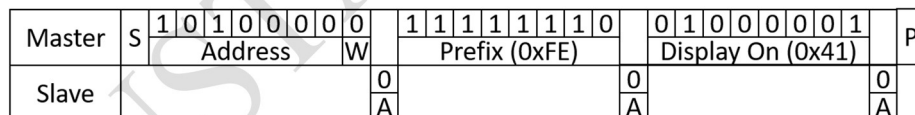

Method 2:

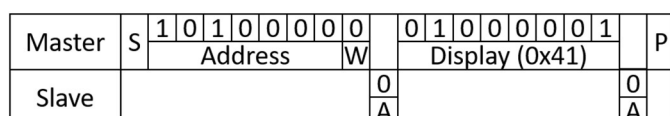
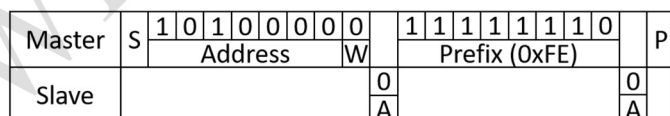

WINSTAR DISPLAY CO., LTD

When sending the "Read Data" command, it can be done in the following ways:

Method 1:

Master	S	1 0 1 0 0 0 0 0	0	1 1 1 1 1 1 1 0	0 1 1 1 0 0 1 1	1 1 1 1 1 1 1 0	P
		Address	W	Prefix (0xFE)	Read Data (0x73)	Dummy Byte (0xFF)	
Slave			0		0		0
			A		A		A

Master	S	1 0 1 0 0 0 0 0	1		0	P
		Address	R		A	
Slave			0	X X X X X X X X		
			A	Data (0xFF)		

Method 2:

Master	S	1 0 1 0 0 0 0 0	0	1 1 1 1 1 1 1 0		P
		Address	W	Prefix (0xFE)		
Slave			0		0	
			A		A	

Master	S	1 0 1 0 0 0 0 0	0	0 1 1 1 0 0 1 1		P
		Address	W	Read Data (0x73)		
Slave			0		0	
			A		A	

Master	S	1 0 1 0 0 0 0 0	0	X X X X X X X X		P
		Address	W	Dummy Byte (0xFF)		
Slave			0		0	
			A		A	

Master	S	1 0 1 0 0 0 0 0	1		0	P
		Address	R		A	
Slave			0	X X X X X X X X		
			A	Data (0xFF)		

- S: Start Condition
- W: Write Operation
- R: Read Operation
- A: Acknowledge
- N: No Acknowledge
- P: Stop Condition

4. Self-Test

In Self-Test mode, the backlight is turned on, and the brightness gradually increases from the darkest to the brightest level.

Then, the display contrast is adjusted, starting from the lightest to the darkest level.

Finally, the firmware version, UART baud rate, and I2C address are displayed sequentially.

5. Jumper selection for communication

Protocol	JB1	JB0	Description
UART	Short	Short	5V TTL Single, default baud rate 9600bps.
SPI	Short	Open	100KHz max clock.
I2C	Open	Short	100KHz max clock, default slave address 0xA0. (with Read/Write bit)
Self-Test	Open	Open	Self-Test mode.

15.1. Instruction

1. Instruction List

Prefix	Command	Parameter	Description	Execution Time
-	-	1 Byte	Display Character (0x00 ~ 0xFF without 0xFE)	530us
0xFE	0x41	None	Display On	400us
0xFE	0x42	None	Display Off	400us
0xFE	0x45	1 Byte	Set Cursor Position	400us
0xFE	0x46	None	Cursor Home	1900us
0xFE	0x47	None	Cursor On	400us
0xFE	0x48	None	Cursor Off	400us
0xFE	0x49	None	Cursor Shift Left	400us
0xFE	0x4A	None	Cursor Shift Right	400us
0xFE	0x4B	None	Cursor Blink On	400us
0xFE	0x4C	None	Cursor Blink Off	400us
0xFE	0x4E	None	Backspace	800us
0xFE	0x51	None	Clear Display	2.2ms
0xFE	0x52	1 Byte	Contrast Setting	28ms
0xFE	0x53	1 Byte	Backlight Setting	28ms
0xFE	0x54	9 Byte	Set Custom Character	3ms
0xFE	0x55	None	Shift Display Left	800us
0xFE	0x56	None	Shift Display Right	800us
0xFE	0x61	1 Byte	Change Baud Rate	28ms
0xFE	0x62	1 Byte	Change I2C Address	28ms
0xFE	0x70	None	Display Firmware Version	6.4ms
0xFE	0x71	None	Display Baud Rate	6.8ms
0xFE	0x72	None	Display I2C Address	6.8ms
0xFE	0x73	1 Dummy Byte	Read Data	430us

2. Instruction Description

Display Character

Syntax hexadecimal 0xFE [CHAR]

Parameters	Parameter	Length	Description
	[CHAR]	1 byte	0x00~0xFF without 0xFE.

Description

To display text, just send the its ASCII code directly.

A number from 0x00 to 0x07 displays the user-defined custom character, 0x20 to 0x7D displays the standard set of characters.

Other display characters and symbols that are factory-masked on the LCD controller.

0xFE is reserved code.

If the user sends the byte 0xFE, the next byte sent afterward will be considered as part of the instruction.

Display On

Syntax hexadecimal 0xFE 0x41

Parameters	Parameter	Length	Description
	None	None	None

Description

This command turns on the LCD display screen.

Display Off

Syntax hexadecimal 0xFE 0x42

Parameters	Parameter	Length	Description
	None	None	None

Description

This command turns off the LCD display screen, but the displayed text is not altered.

Set Cursor Position

Syntax hexadecimal 0xFE 0x45 [POSITION]

Parameters	Parameter	Length	Description
	[POSITION]	1 Byte	Put cursor at location specified by [POSITION].

Description This command moves the cursor to specific position.
After the reset, the cursor is on position 0x00.

	Column 1	Column 20
Line 1	0x00	0x13
Line 2	0x40	0x53

Cursor Home

Syntax hexadecimal 0xFE 0x46

Parameters	Parameter	Length	Description
	None	None	None

Description This command moves the cursor to line 1, column 1 of the LCD.

Cursor On

Syntax Hexadecimal 0xFE 0x47

Parameters	Parameter	Length	Description
	None	None	None

Description This command turns on the underline cursor.
Cursor default value is off.

Cursor Off

Syntax hexadecimal 0xFE 0x48

Parameters	Parameter	Length	Description
	None	None	None

Description This command turns off the underline cursor.
Cursor default value is off.

Cursor Shift Left

Syntax hexadecimal 0xFE 0x49

Parameters	Parameter	Length	Description
	None	None	None

Description This command moves the cursor position left 1 space whether the cursor is turned on or off, and the displayed text is not altered.

Cursor Shift Right

Syntax hexadecimal 0xFE 0x4A

Parameters	Parameter	Length	Description
	None	None	None

Description This command moves the cursor position right 1 space whether the cursor is turned on or off, and the displayed text is not altered.

Cursor Blink On

Syntax hexadecimal 0xFE 0x4B

Parameters	Parameter	Length	Description
	None	None	None

Description This command turns on the blinking cursor.
Cursor blink default value is off.

Cursor Blink Off

Syntax hexadecimal 0xFE 0x4C

Parameters	Parameter	Length	Description
	None	None	None

Description This command turns off the blinking cursor.
Cursor blink default value is off.

Backspace

Syntax hexadecimal 0xFE 0x4E

Parameters	Parameter	Length	Description
	None	None	None

Description This command is destructive backspace.
The cursor is moved back one space and the character on the cursor is deleted.

Clear Display

Syntax hexadecimal 0xFE 0x51

Parameters	Parameter	Length	Description
	None	None	None

Description This command clears the entire display and place the cursor at line 1 column 1.

Contrast Setting

Syntax hexadecimal 0xFE 0x52 [CONTRAST]

Parameters	Parameter	Length	Description
	[CONTRAST]	1 Byte	Set the display contrast, value between 1 and 50.

Description This command adjusts the contrast of the LCD character display.
The contrast level can be set within a range of 1 to 50, where 50 represents the highest contrast.
This value will be stored in the internal EEPROM. The default setting is 40.

Backlight Setting

Syntax hexadecimal 0xFE 0x53 [BRIGHTNESS]

Parameters	Parameter	Length	Description
	[BRIGHTNESS]	1 Byte	Set the LCD backlight brightness level, value between 1 to 8.

Description This command adjusts the backlight brightness level, with the selected value being saved to the internal EEPROM.
The default setting is level 8.
A setting of 1 turns the backlight off, whereas a setting of 8 corresponds to 100% backlight brightness.

Set Custom Character

Syntax hexadecimal 0xFE 0x54 [ADDRESS] [DATA0 ... 7]

Parameters	Parameter	Length	Description
	[ADDRESS]	1 Byte	Custom character address, 0 – 7.
	[DATA0 ... 7]	8 Byte	Custom character pattern bit map.

Description

This command used to generate custom character.

The custom character pattern is bit mapped into 8 bytes, allowing for a total of eight customizable characters. To display custom characters, enter addresses 0-7.

If the user wants to place the Spanish character '¿' at the address 0x07, then send 0xFE 0x54 0x07 0x04 0x00 0x04 0x08 0x10 0x11 0x0E 0x00.

The bitmap for the Spanish character '¿' is shown in the table below.

Bit	7	6	5	4	3	2	1	0	HEX
Data0	0	0	0	0	0	1	0	0	0x04
Data1	0	0	0	0	0	0	0	0	0x00
Data2	0	0	0	0	0	1	0	0	0x04
Data3	0	0	0	0	1	0	0	0	0x08
Data4	0	0	0	1	0	0	0	0	0x10
Data5	0	0	0	1	0	0	0	1	0x11
Data6	0	0	0	0	1	1	1	0	0x0E
Data7	0	0	0	0	0	0	0	0	0x00

Shift Display Left

Syntax hexadecimal 0xFE 0x55

Parameters	Parameter	Length	Description
	None	None	None

Description

This command shifts the display to the left 1 space.

The cursor position also moves with the display, and the displayed text is not altered.

Shift Display Right

Syntax hexadecimal 0xFE 0x56

Parameters	Parameter	Length	Description
	None	None	None

Description This command shifts the display to the right 1 space.
The cursor position also moves with the display, and the displayed text is not altered.

Change Baud Rate

Syntax hexadecimal 0xFE 0x61 [BAUD]

Parameters	Parameter	Length	Description
	[BAUD]	1 Byte	New UART baud rate, 3 ~ 7

Description This command is used to set the UART baud rate, with the default value being 4 (means 9600bps). The single-byte parameter selects the desired baud rate as indicated in the table below. The newly set baud rate takes 28 microseconds to become effective; hence, subsequent inputs must consider an appropriate delay.
If Self-Test mode is selected, the default baud rate will be restored.
The set baud rate value is stored in the internal EEPROM.
Any illegal parameter inputs will be disregarded.

EX:

(X) 0xFE 0x61 0x01

(O) 0xFE 0x61 0x03

Parameter	Baud Rate
3	4800bps
4	9600bps
5	14400bps
6	19200bps
7	57600bps

Change I2C Address

Syntax hexadecimal 0xFE 0x62 [ADDRESS]

Parameters	Parameter	Length	Description
	[ADDRESS]	1 Byte	New I2C address, 0x00 - 0xFE. The LSB is always '0'.

Description This command sets the I2C address. The address must be an even number (LSB = 0).
The address change requires 28 microseconds to take effect; therefore, the subsequent input must have an appropriate delay.
The default I2C address can be restored if Self-Test mode is selected.
The set I2C address value is stored in the internal EEPROM.
Illegal parameter input will be discarded.

EX:

(X) 0xFE 0x62 0xA1

(O) 0xFE 0x62 0xA0

Display Firmware Version

Syntax hexadecimal 0xFE 0x70

Parameters	Parameter	Length	Description
	None	None	None

Description This command displays the micro-controller firmware version number.

Display Baud Rate

Syntax hexadecimal 0xFE 0x71

Parameters	Parameter	Length	Description
	None	None	None

Description This command displays the current UART baud rate.

Display I2C Address

Syntax hexadecimal 0xFE 0x72

Parameters	Parameter	Length	Description
	None	None	None

Description This command displays the current I2C address.

Read Data

Syntax hexadecimal 0xFE 0x73 [DUMMY]

Parameters	Parameter	Length	Description
	[DUMMY]	1 Byte	Last data byte is a dummy byte. This byte could be any value from 0x00 to 0xFF.

Description This command reads the data at the current position of the cursor on the LCD.

EX:

The current LCM screen is shown below:

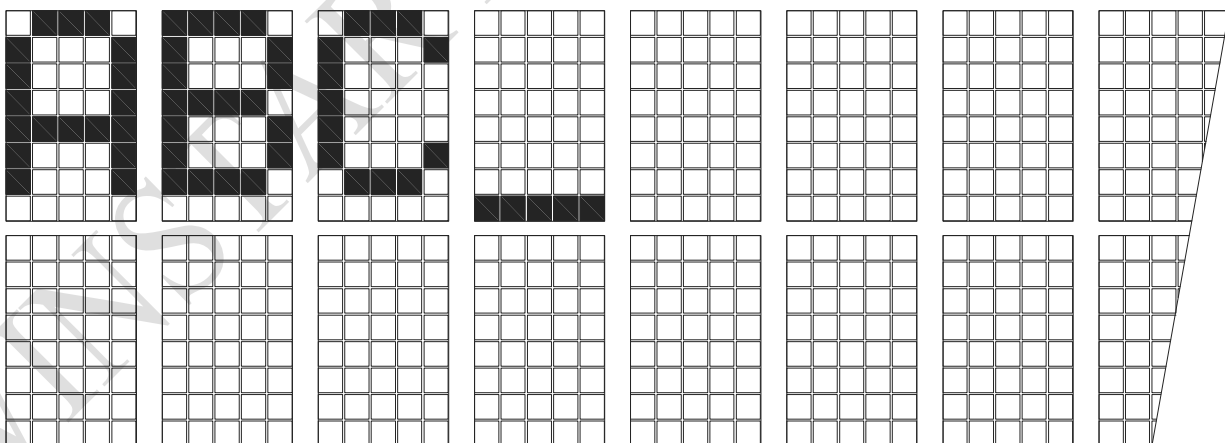

The UART Read Data sequence is as follows:

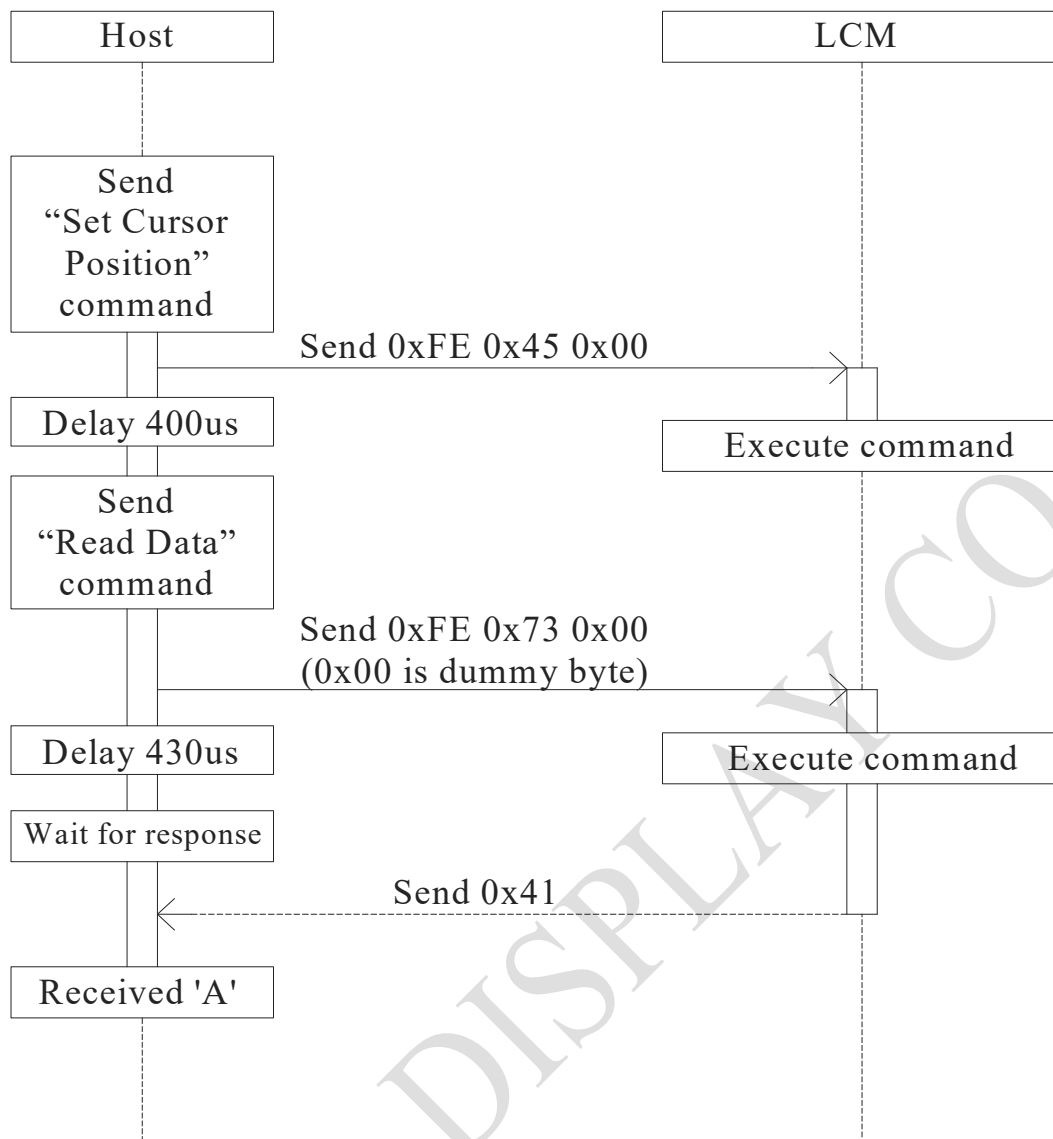

The SPI Read Data sequence is as follows:

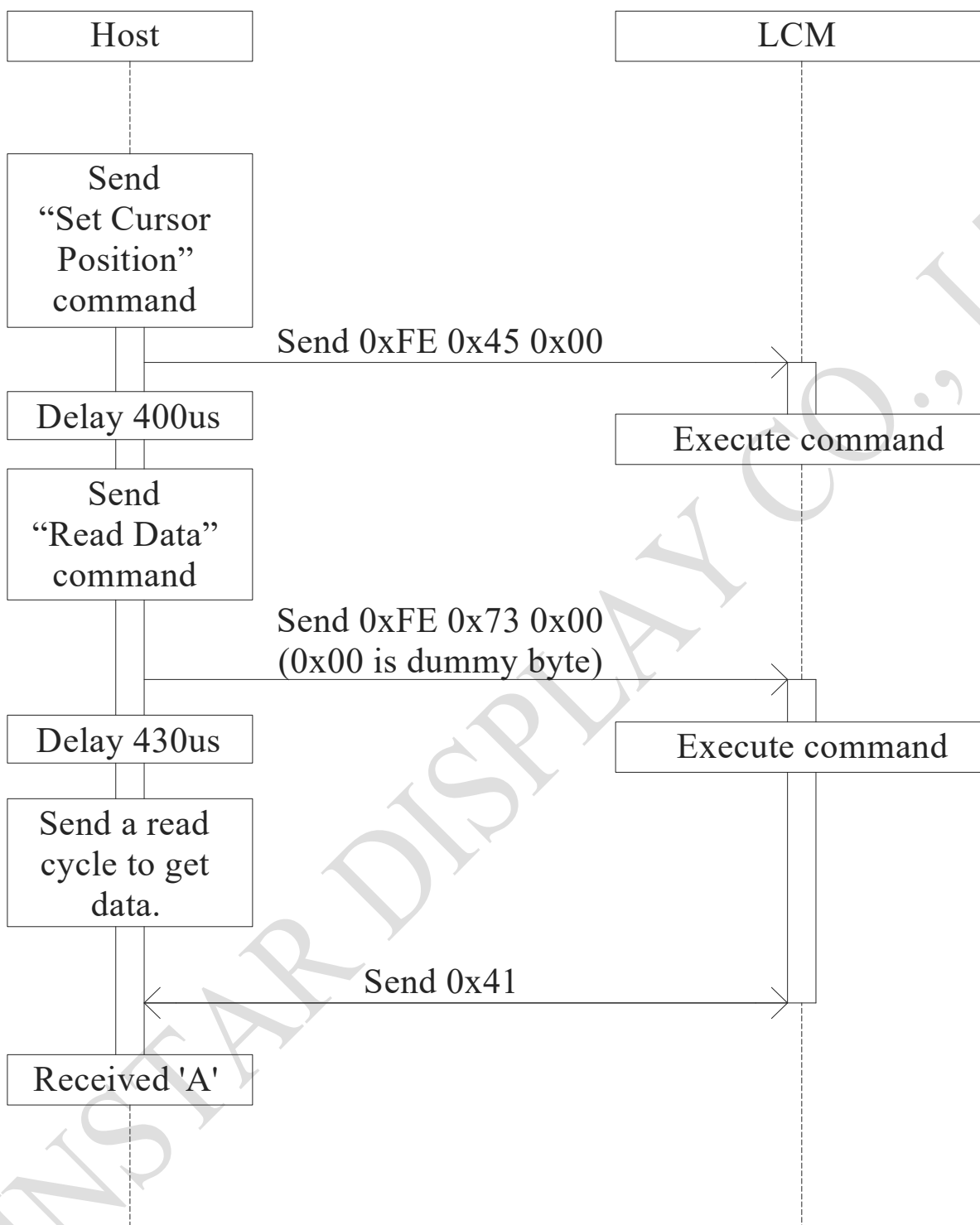

The I2C Read Data sequence is as follows:

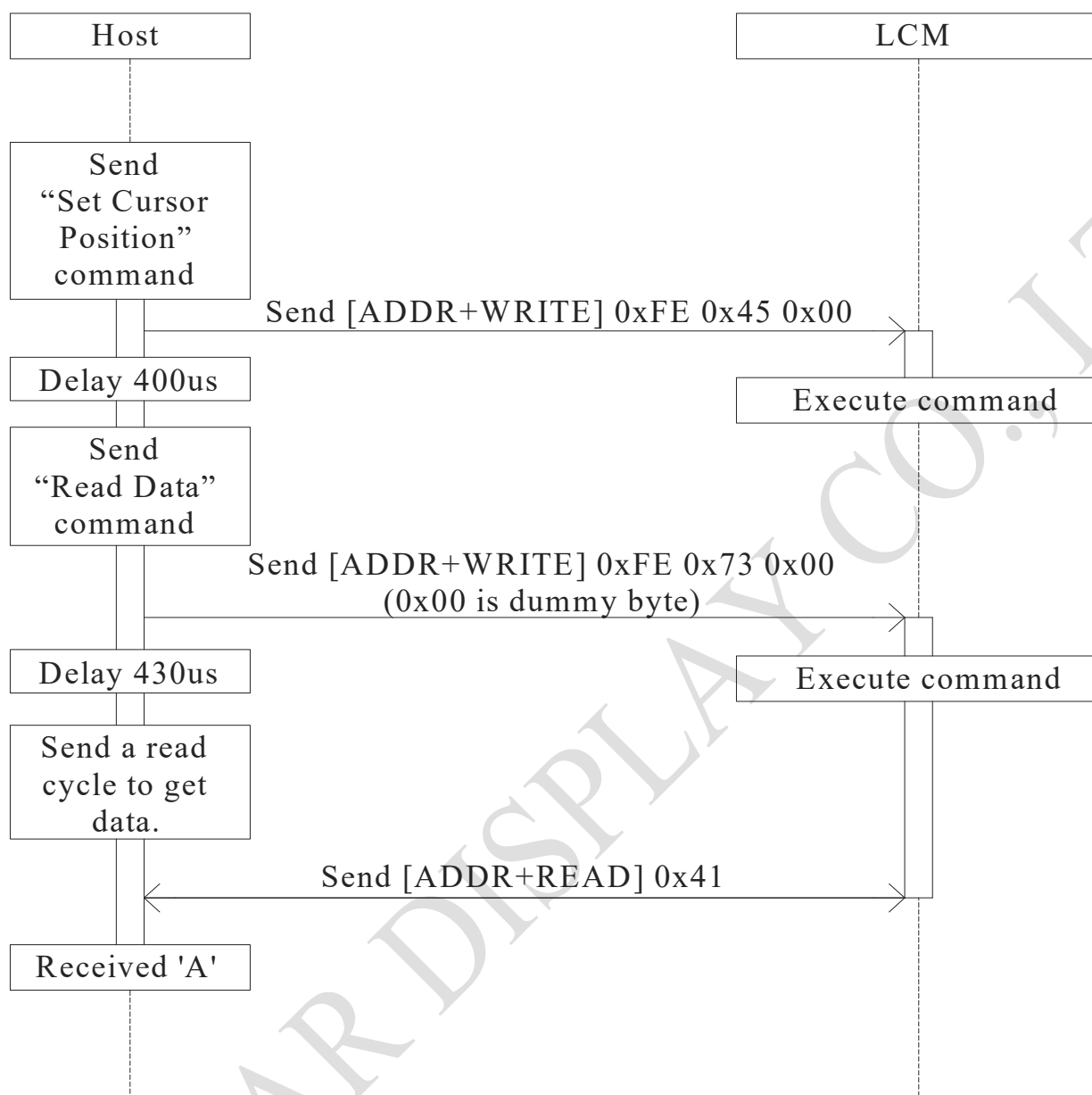



1、Panel Specification :

- 1. Panel Type : Pass NG , _____
- 2. View Direction : Pass NG , _____
- 3. Numbers of Dots : Pass NG , _____
- 4. View Area : Pass NG , _____
- 5. Active Area : Pass NG , _____
- 6. Operating Temperature : Pass NG , _____
- 7. Storage Temperature : Pass NG , _____
- 8. Others : _____

2、Mechanical Specification :

- 1. PCB Size : Pass NG , _____
- 2. Frame Size : Pass NG , _____
- 3. Material of Frame : Pass NG , _____
- 4. Connector Position : Pass NG , _____
- 5. Fix Hole Position : Pass NG , _____
- 6. Backlight Position : Pass NG , _____
- 7. Thickness of PCB : Pass NG , _____
- 8. Height of Frame to PCB : Pass NG , _____
- 9. Height of Module : Pass NG , _____
- 10. Others : Pass NG , _____

3、Relative Hole Size :

- 1. Pitch of Connector : Pass NG , _____
- 2. Hole size of Connector : Pass NG , _____
- 3. Mounting Hole size : Pass NG , _____
- 4. Mounting Hole Type : Pass NG , _____
- 5. Others : Pass NG , _____

4、Backlight Specification :

- 1. B/L Type : Pass NG , _____
- 2. B/L Color : Pass NG , _____
- 3. B/L Driving Voltage (Reference for LED Type) : Pass NG , _____
- 4. B/L Driving Current : Pass NG , _____
- 5. Brightness of B/L : Pass NG , _____
- 6. B/L Solder Method : Pass NG , _____
- 7. Others : Pass NG , _____

>> Go to page 2 <<



Module Number : _____

5、Electronic Characteristics of Module :

- | | | |
|------------------------------|-------------------------------|-------------------------------------|
| 1. Input Voltage : | <input type="checkbox"/> Pass | <input type="checkbox"/> NG , _____ |
| 2. Supply Current : | <input type="checkbox"/> Pass | <input type="checkbox"/> NG , _____ |
| 3. Driving Voltage for LCD : | <input type="checkbox"/> Pass | <input type="checkbox"/> NG , _____ |
| 4. Contrast for LCD : | <input type="checkbox"/> Pass | <input type="checkbox"/> NG , _____ |
| 5. B/L Driving Method : | <input type="checkbox"/> Pass | <input type="checkbox"/> NG , _____ |
| 6. Negative Voltage Output : | <input type="checkbox"/> Pass | <input type="checkbox"/> NG , _____ |
| 7. Interface Function : | <input type="checkbox"/> Pass | <input type="checkbox"/> NG , _____ |
| 8. LCD Uniformity : | <input type="checkbox"/> Pass | <input type="checkbox"/> NG , _____ |
| 9. ESD test : | <input type="checkbox"/> Pass | <input type="checkbox"/> NG , _____ |
| 10. Others : | <input type="checkbox"/> Pass | <input type="checkbox"/> NG , _____ |

6、Summary :