



XT-S240

240 Lines Solid-State Flash Lidar

Product Manual

2024-04

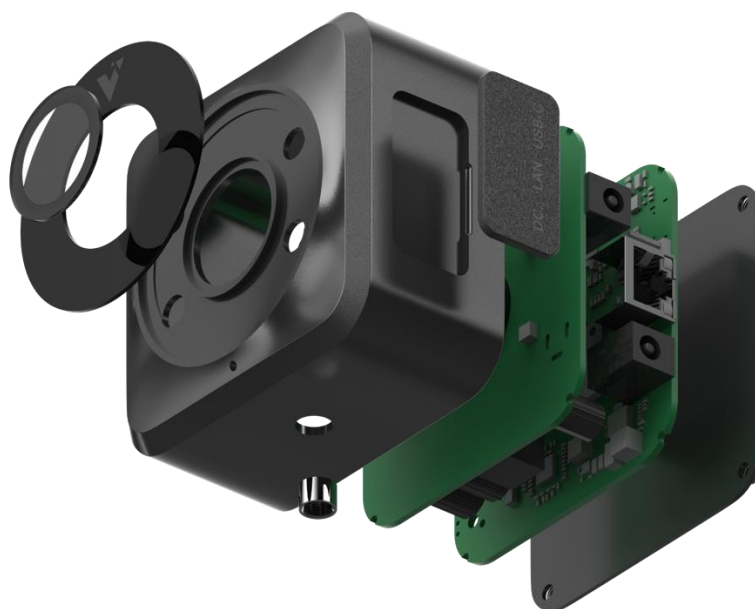



About the manual

■ Using tips

- Please be sure to read the manual carefully before use the product, and operate the product following the instruction to avoid product damage, damage to other property, personal injury or violation of warranty terms
- This manual does not contain the product authentication information, please check the authentication information at the bottom of the product brand, and query the corresponding certification reminder.
- If this Lidar products as part of your product, please provide this manual to your product expectation users, or provide the acquiring method of the manual.

■ Access

Please acquire the latest version of manual through the following ways:

- Contact sales staff or corresponding sales channel staff of Toffuture
- Contact technical support of Toffuture: info@toffuture.com

■ Technical support

If the manual can't solve problems, please contact us through the following way:

info@toffuture.com

■ Legend

- Warning: be sure to follow the safety instructions or the correct operation method.
- Attention: supplementary information, for better usage of the product



Safety warning

■ Laser safety

Laser Safety	
	<p>This product will emit invisible laser during operation, please avoid eye damage during operation.</p> <p>This product pass the Class 1 safety level and has obtain the human eye safety CB certification, according to the EN60825 requirement, it will not damage the human eye and body during normal operation.</p> <p>Please use the product correctly!(Avoid direct view to the Lidar)</p>

Human eye safety

This is the laser product, in order to protect the user, it's strongly recommended that avoiding the direct view to the laser through the magnifying equipment (like microscope and any kind of magnifying lens) during product operation.

This product have no power switch, it will operate once the power is connected;

During the product operation, the whole light cover can be treated like the laser emit area, direct look to the light cover could be treated like the direct view to the laser during operation.

■ High temperature

Avoid direct contact with the products shell during the product operation or right after the product operation.



Please check the working temperature within the chapter “technical parameter” of the user manual, avoid the working environment which exceed the working temperature.

Operating in the environment like high/low temperature, strong vibration, heavy fog etc. might reduce the XT-S240 performance.

In addition, long working time in the high temperature environment might impact the product performance or even damage the product.



It's strongly recommended that user add radiating precaution to make sure the shell temperature won't exceed 60 degree.

If the product temperature is too high, it will trigger the high temperature self-protection mechanism, XT-S240 will send out the high temperature warning, if the temperature is too high, XT-S240 will stop the operation, and restart only after the temperature reach the normal level.

Recommand storage environment:

Dry and ventilated environment, temperature $23\pm 5^{\circ}\text{C}$, humidity 30%~70%.

■ **Abnormal stop**

If occur the following circumstances, please immediately stop using the product and contact the Toffuture or corresponding sales channel staff of Toffuture:

- Suspect product failure or damage, for example, the product have obvious noise, smell or smoke
- User or people around feel any discomfort of themselves
- Abnormal running equipment in the surrounding environment

■ **Disassembly prohibited**

Without the written consent of Toffuture, disassembly is explicitly prohibited of this product.



About the manual.....	2
■ Using tips	2
■ Access	2
■ Technical support.....	2
■ Legend	2
Safety warning	3
■ Laser safety	3
■ High temperature	3
■ Abnormal stop	3
■ Disassembly prohibited	4
Product introduction	6
Product highlights.....	6
1、 The product features	7
1.1 Working principle	7
1.2 Technical parameters	8
2、 Products mechanical structure	9
3、 Products six view.....	9
Product shell	10
Light cover of the shell	10
High temperature	10
4、 Installation Angle.....	11
4.1 Effective field of view (FOV) Angle range	11
4.2 Field of view(FOV) detection range	11
5、 Installation and operation	12
The power supply	12
Electrical interface	12
6、 Component description.....	13
7、 Data output.....	14
7.1 Three different types of communication data:	14
7.2 Communication packet format(based on TCP/UDP/USB) packet format definition.....	14
7.3 Data flow	15
7.4 Command data	17
7.5 Command list:	18
7.6 Command type:	18

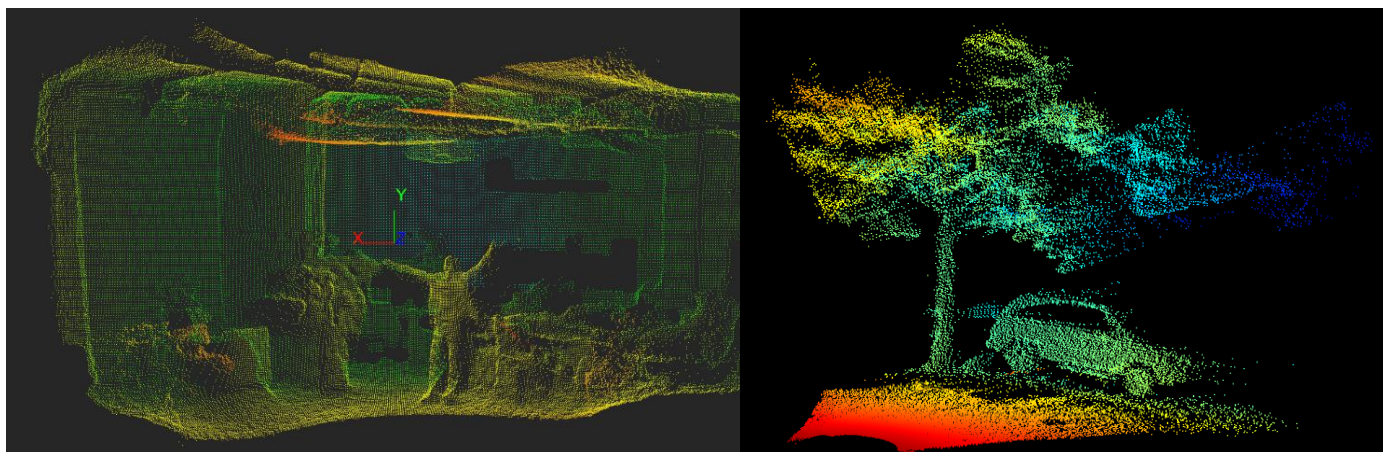

Product introduction

XT - S240 is a cost-effective, safe and reliable pure solid state Lidar sensor. Can be widely used in industry of automatic driving and handling robot, indoor/outdoor service robots, unmanned aerial vehicle, and many other areas, such as AGV, AMR, automatic forklift, field mower, cleaning robot etc.

Product highlights

Solid State :	No mechanical parts, reliable .
Ultra small size :	68 mm * 68 mm * 48 mm
240 Line :	The equivalent of 240 lines, 76800 pixels/frame Angular.
Resolution:	XT-S240Mini 0.33 ° XT-S240Pro 0.22 °
Anti-blooming:	In the 100Klux sunlight environment can work properly and provide stable point cloud
Multiple images:	Output 3D point cloud, depth map, the infrared gray, incredible figure, etc
Multiple interfaces:	Type C debugging interface, 100 BaseT front-end ports, air interface (custom).
Automotive Grade:	Mature silicon semiconductor technology, reliability, consistency, stability, security, high integration, simple structure, low fault rate and meet the mass demand of clients.



1、 The product features

1.1 Working principle

The distance measurement principle is the Flight Time measurement (Time of Flight).

- 1) Emit ultrashort laser pulses.
- 2) Laser reach the object and reflection, photosensitive receiver receives the reflected light.
- 3) By measuring the flight time of the laser in the air, we can accurately calculate the distance between target object and the sensors.

ToF is the abbreviation of Time - of - Flight, the Flight Time of light, essentially it is one kind of depth range camera to provided the high quality depth image, ToF, the structure light and the eyes constitute three mainstream of 3D visual technology.

iToF is the abbreviation of indirect Time - of - Flight, dToF is the abbreviation of direct Time - of - Flight.

For iToF, it has high resolution, high accuracy performance. On the other side, for dToF, it has high sensitivity and long detection range. For differnet application, different technical approach could be taken.

$d = c * t / 2$	d: Distance c: Speed of Light t: Fly time of the laser pulse
-----------------	--

Figure1.1 ToF distance calculation formula



1.2 Technical parameters

Product Name	S Series-Short Range			M Series-Middle Distance	
	XT-S240 Mini	XT-S240 Pro	XT-S240 (customized)	XT-M120Mini	XT-M120 Pro
Application	Low/Medium Speed			Medium Speed	
FOV1 (Image View)	106°×80°	72°×58°	106°×80°; 106°×30°; 60°×45°; 32°×24°;	106°×80°	72°×58°
FOV2 (Photology)\Structure\ Mechanical View)	120°×94°	77°×64°	TBD	120°×94°	77°×64°
Light Wavelength(nm)	940			940	
Average Power(W)	6		6-10	12	
Output Data	Infrared Image/Depth Image/3D Point Cloud				
SDK	C++/Python/Linux/Ros1&Ros2				
Accuracy	1-3%				
Angle Resolution	0.33°H×0.33°V (equal to 240 line)	0.22°H×0.24°V (equal to 240 lines)	0.33°H×0.33°V (equal to 90-240 lines)	0.33°H×0.66°V (equal to 120 lines)	0.22°H×0.48°V (equal to 120 lines)
Measurement Distance (50% Reflectivity)	10m outdoor (0.3-12m indoor)	15m outdoor (0.3-20m indoor)	80m outdoor (0.3-100m indoor)	20m outdoor (0.3-25m indoor)	30m outdoor (0.3-40m indoor)
Frame Rate (fps)	1-20 frames			1-35 frames	
Size (mm)	68×68×48	68×68×45	Optional	72×72×48	72×72×45
Weight (g)	205g	197g	Optional	293g	277
Voltage	12-25V(DC)@3A		12-25V@3A/optional interface	12-25V@5A, Air interface	
Working Temperature	-20°to60°	-20°to60°	Optional	-40°to85°	

Special Reminder:

1. FOV1, represent the field of view of the image receiver side, which is the angle of the output image and 3D point cloud. Using FOV1 as the parameter for image, software, algorithm, point cloud related applications.
2. FOV2 represent the field of view of the laser emitter, due to light interference and multi-path interference, FOV2 must be larger than FOV1. Using FOV2 as the parameter for the photology, structure, machinery and installation related applications.
3. Marked on the 3D models, application and question related to mould making and precise mechanical structure, please contact the technical support for confirmation to avoid unnecessary loss. Thank you!



2、Products mechanical structure

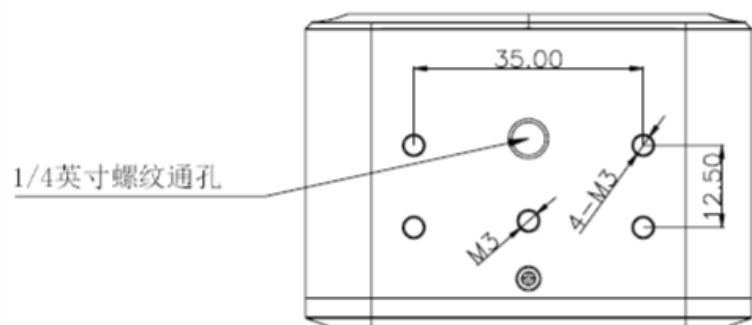
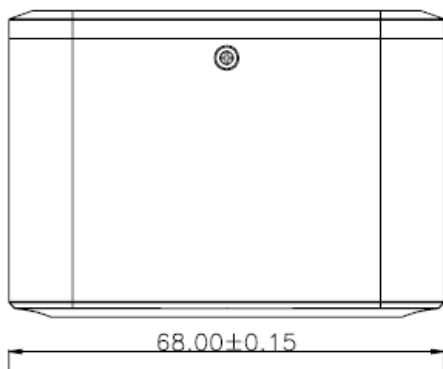
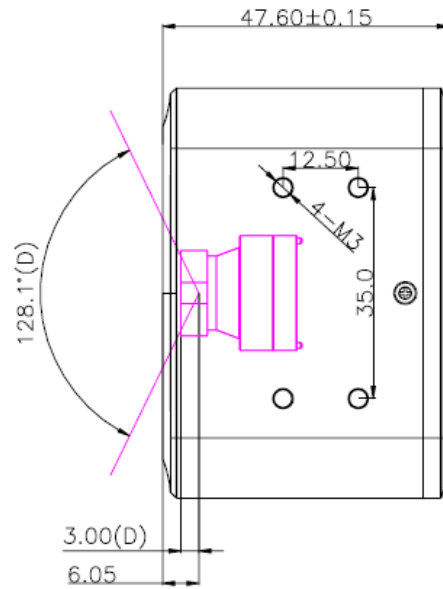
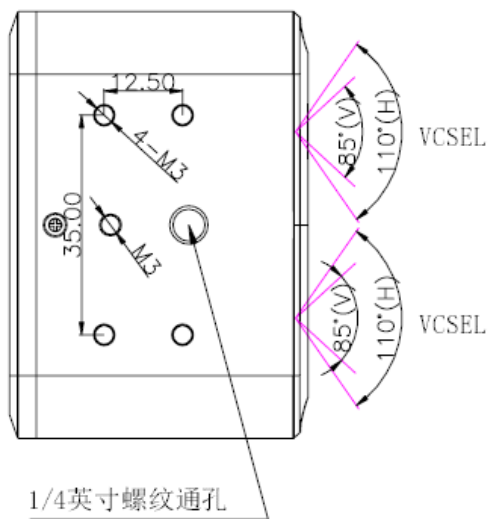
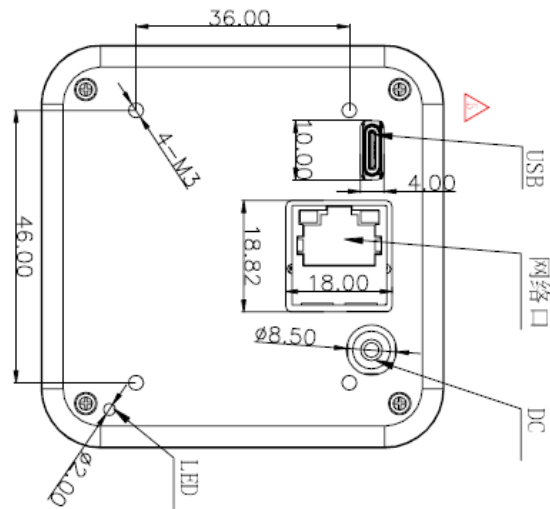
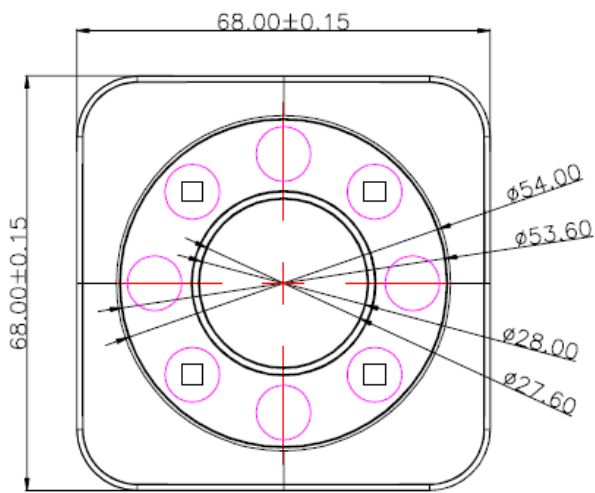



3、 Structure Description

Product shell

- The products are mainly made of metal, glass and copper clad, internal contain sensitive electronic components, must avoid dropping, burning and other improper operation. Once the product experience falling or burning, please stop using immediately, and contact Toffuture for technical support.
- Avoid extrusion or puncture of the product. If the shell is damaged, please stop using immediately.
- Before active the product, please ensure that the product has been firmly fixed, and avoid the external force (such as the impact, wind, flying rock, etc.) which might move the product from a fixed position.

Light mask of the shell

- Do not touch the mask, lest the mask with fingerprints or dirt. If the mask is not clean already, please follow the decirbed methed in the section “instrument maintenance” of instructions to clean.
- Please avoid contact with hard or sharp object for scratches in the mask. Please stop using the product with serious scratches since it may affect the product performance.

High temperature

During the products operation or a certain period of time after the product operation, the product shell may be in high temperature condition, please note that:

- Avoid direct skin contact with the product shell, which might casuing the skin burned.
- Avoid direct contact with product shell using combustible materials , which might cause a fire.



4、Installation Angle

4.1 Effective field of view (FOV) Angle range

XT - S240 Mini FOV is $106^{\circ} \times 80^{\circ}$, pay attention to the FOV range, avoid blocking and interference.

Contact the agent or info@toffuture.com for the FOV 3D model of the mechanical installation.

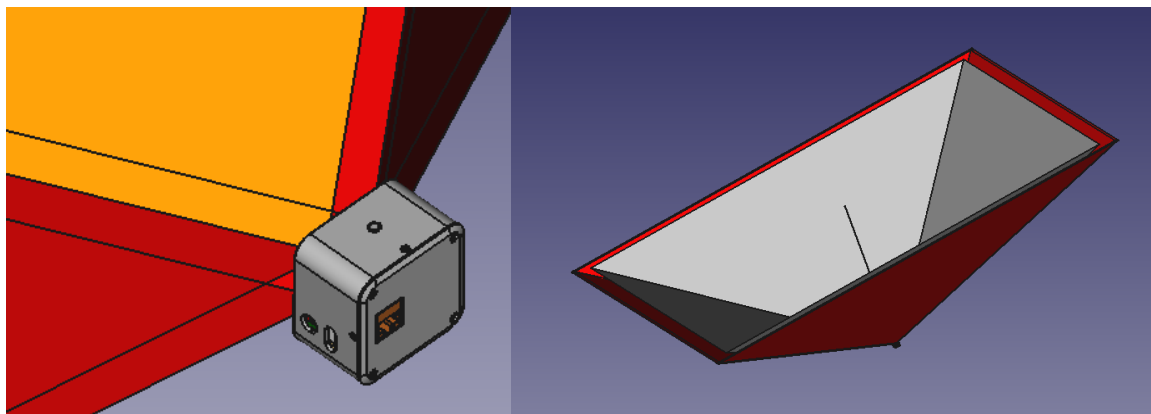

4.2 Field of view(FOV) detection range

The following model server the purpose to convenient customers to intuitive understand the detection range covering by the product (spherical coordinates) under different FOV and distance measuring range, in order to select a better corresponding FOV of products for different applications.

FOV	$106^{\circ} * 80^{\circ}$	$72^{\circ} * 58^{\circ}$	$106^{\circ} * 30^{\circ}$	$60^{\circ} * 45^{\circ}$	$32^{\circ} * 24^{\circ}$
Measurement Range (@5m)	13.3m * 8.4m	7.3m * 5.5m	13.3m * 2.7m	5.8m * 4.1m	2.9m * 2.1m
Measurement Covered Area	111.4 m ²	40.3 m ²	35.6 m ²	23.9 m ²	6.1 m ²
Measurement Range (@10m)	26.5m * 16.8m	14.5m * 11.1m	26.5m * 5.3m	11.5m * 8.3m	5.7m * 4.3m
Measurement Covered Area	445.4 m ²	161.1 m ²	142.2 m ²	95.7 m ²	24.4 m ²
Measurement Range (@20m)	53.1m * 33.6m	29.1m * 22.2m	53.1m * 10.7m	23.1m * 16.6m	11.5m * 8.5m
Measurement Covered Area	1781.6 m ²	644.4 m ²	568.9 m ²	382.6 m ²	97.5 m ²

For more detail, check below:



<http://www.toffuture.com/xzzl> → 不同 FOV 覆盖区域计算-芯探科技.xlsx



5、 Installation and operation

The power supply

·Recommend to use power supply cable and power adapter offered by Toffuture.

Power supply: Delippo	Purchase Link	
19V 3.42A	https://item.jd.com/100049765921.html	
12V 3A	https://item.jd.com/100047619867.html	

• For the customer design, configuration or selected power supply system (including cables) by themselves, please follow the relevant electrical parameters in the instructions, or contact the Toffuture for technical support. Using damaged cable, adapter or the power supply which dose not meet the requirement is forbidden.

Electrical interface

·Before power on, please make sure that the electrical outlet is dry and has no dirt. Please do not power on the product in the humid environment

·Please strictly follow the connector plug operation instructions. If you have already found abnormal interface (such as pin skewed, cable breakage and screw loosening, etc.), please stop using the product and contact Toffuture for technical support.

·Before you plug connector, please disconnect the power supply. Hot plug can lead to damage.



6、Component description

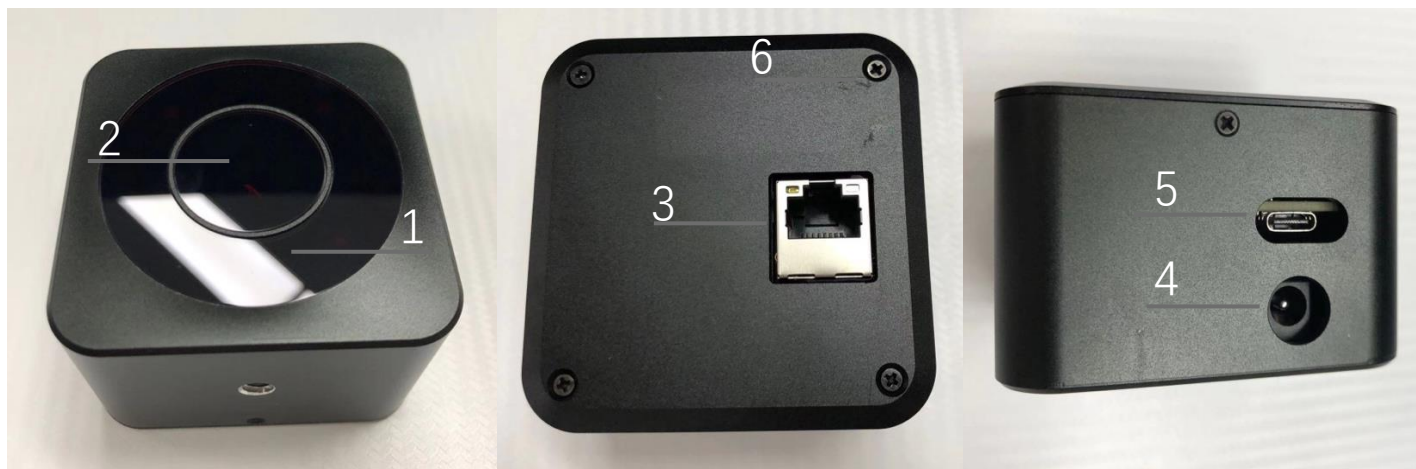

1. Big baffle Vcsel launch window, light through the window for launch, detect the objects within FOV range.

2. Small baffle is sensor receiving window, receiving the reflected light reflected from the object.

3.100 BasT card, provide Lidar data output

4. DC interface, power 15 v - 25 v (current above 3a) Recommend: [绿联](#)

5. Type C interface, USB with Lidar data output

6. M2 screws, outside the module using this Type of screw

7. Universal 1/4 threaded hole

8. LED light

definition as below:

1. Power on: yellow light always on

2. Communication stable, not working: green light always on

3. During normal working: green light blink

4. Error: red light blink





7、Data output

This protocol is based on TCP/UDP

default radar TCP port: 7787

default UDP port:7687

7.1 Three different types of communication data:

- Video data with large data flow ,

Due to the consideration of the real time requirement, UDP protocol has be chosen. UDP data is transmitted by the radar and accpeted by the upper computert.

- Radar command interaction ,

Due to the requirement of the clear result of the excution interaction and the small amout of the data,TCP protocol has be chosen to secure the interaction integrity.

- Debug log information reported by radar ,

In order to make sure the upper computer recevied the debug log data, and with the small amount of the data flow, TCP protocol has be chosen.

Checking the connection between the radar and upper computer:

Option 1: Checking the heartbeat by checking the TCP conection

Option 2: Upper computer send the command in certian period, check the time of the last received command by the radar

7.2 Communication packet format(based on TCP/UDP/USB) packet format definition

Start	data packet size	data	End
4Bytes(0x7EFFAA55)	4Bytes	0-30720	4Bytes(0XFF7E55AA)

Start	data packet size	ID	Command data	State code	Protocol version number	End
4Bytes(0x7EFFAA55)	4Bytes	1Byte	0-30720	1 Byte(b4-b7: state cod b0-b3:command reture code	1 Byte	4Bytes(0XFF7E55AA)

Using the network order(big endian as the byte oorder of the data.)

Using the little endian for the storage in radar and upper computer



TCP/UDP level has the checksum for the network data, as the result the XT packet doesn't contain the checksum.

Dividing one frame data into multiple UDP packets to transfer (20 bytes packet header + 1400 bytes data), Because each network packet size is smaller than MTU

7.3 Data flow

Data include: depth, amplitude, grayscale, temperature, time

Output type:

1. depth + temperature + time
2. depth + amplitude + temperature + time
3. grayscale + temperature + time

Since one frame data is divided into multiple data packets, after receiving the data packets, it must be reformed into one complete frame to be used. Upper computer SDK convert the distance data coordinate into point cloud data.

Data format of one frame:

cmdid	output type	frame number	resolution	data	temperature	time mark	integration time	reserve	state code	version
1 Bytes 251	1 Byte	2 Bytes	4 Bytes	0-307200 Bytes pixel data	2 Bytes	8 Bytes Unit:us	8 Bytes	32 Bytes Device state info	1 Byte	1 Byte
Position: 8+0	8+1	8+2	8+4	8+8	8+8+Dsize	8+8+Dsize+ 2	8+8+Dsize+1 0	8+8+Dsize+1 8	8+8+Dsize+5 1	8+8+Dsize+52

Pixel format:

Output type	Description	Byte size
1	Depth	2 Bytes
2	Depth + Amplitude	2Bytes + 2Bytes
3	Grayscale	2Bytes



UDP packet division

One complete frame data will be divided into multiple UDP packets before transmission, receiver will reform the UDP packets to the complete frame data

UDP packet structure

Packet Head	Data
20 Bytes	Max 1400 Bytes

UDP packet header structure

Frame number	Frame size	Packet data size	transmitted size	Packet number in total	Packet number
2 Bytes	4 Bytes	2 Bytes	4 Bytes	4 Bytes	4 Bytes

Attention: the data flow contain PTP synchronization time information

Command Response State Code

Device state code: **DevStateCode**

id	Description
0	Unconnected
1	Device Initialization
2	Device Idle
3	Device Busy
4	Error: CSI interface
5	Error: I2C interface
6	Error: temperature too high
7	Error: temperature too low



8	Error: unknow
9-15	reserve

command response code: **CmdRespCode**

id	Description
0	Command execute OK
1	Command unsupport
2	Device busy
3	reserve
4	reserve
5	reserve
6	reserve
7	Report message
8	Error: Command format/size/value
9	Error: Command data
10	Error: CSI interface
11	Error: I2C interface
12	Error: temperature too high
13	Error: temperature too low
14	Error: unknow

7.4 Command data

Command/Response/active report and same format

Blue fint showing the data size of current command, which will not be trasmitted, the packet size will contain the data size information



Command ID	data	datasize
1 Byte	..	0 Byte

7.5 Command list:

Command	ID	Parameter	Description
Image	251		Send out one frame of the image data
Start	1	Type	Start measurement
Stop	2	-	Stop flow
Set IP address	3	IP address, subnet mask, network management IP	Set the internet address
Request device information	4	-	Internet information, device version, product serial number, chipid, calibration status
Request configuration information	5	-	Output image type, frequency, HDR, integration time, min amplitude, filter status
Set filter	6	Edge, Temporal	Set the filter function which to be open and the filter parameter
Set integration time	8	4 group integration time parameter, grayscale integration time	HDR compatible
Set min signal amplitude	9		Discard the signal with too low amplitude
Set HDR	10	Type	
Reset	13	Fixed string "XINTAN"	Reset the radar
Set modulation frequency	52	Frequency number	12m, 6m
Set ROI	51	x0,y0,x1,y1	
Trace output	209	Size, string	Send out the log information

7.6 Command type:

Blue font showing the data size of current command, which will not be transmitted, the packet size will contain the data size information.

	Command ID	Data	Data size
Flow Data	251		0 Byte

Start	Command ID	B0	B1	Data size
Command	1	Image type 1:Depth 2:Depth+Amplitude 3: Grayscale	Once/flow 0/1	2 Bytes



	Command ID	Data size
Response	1	0 Byte

Stop	Command ID	Data	Data size
Command	2		0 Byte

	Command ID	Data size
Response	2	0 Byte

Set IP Address	Command ID	Data	Data size
Command	3	IP 4Bytes Msk: 4 Bytes Gate: 4 Bytes	12 Bytes

	Command ID	Data size
Response	3	0 Byte

Request Device info	Command ID	Data	Data size
Command	4		0 Bytes

	Command ID	Data	Data size
Response	4	IP: 12 Byte Mac Address: 6 Bytes FW Ver: 18 Bytes SN: 28 Bytes Boot Ver: 14 Bytes Status: 1 Bytes Chip ID: 4 Bytes Calibration Status: 2 Bytes Reserve: Remaining Bytes	90 Bytes

Request Configuration Info	Command ID	Data	Data size
Command	5		0 Byte

	Command ID	Data	Data size
Response	5	Output Image Type: 1 Byte Freq: 1 Byte HDR mode : 1 Byte Integration Time : 8 Bytes Min amplitude : 2 Bytes Kalman filter factor : 2 Bytes	30 Bytes



**Kalman threshold : 2 Bytes Flying-spot filter
threshold : 2 Bytes Reserve: Remaining Bytes**

Set Filter	Command ID	Data	Data size
Command	6	Kalman factor: 2 Bytes(0-1000), '0'means closed Kalman threshold: 2 Bytes(0-2000), '0'means closed Flying- spot threshold: 2 Bytes,'0' menas closed	5 Bytes

	Command ID	Data size
Response	6	0 Byte

Set Integration Time	Command ID	Data	Data size
Command	8	4 groups integration time, 2 bytes for each group	8 Bytes

	Command ID	Data size
Response	8	0 Byte

Set Min Amplitude	Command ID	Data	Data size
Command	9	Unit 16 value (0-2000)	2 Bytes

	Command ID	Data size
Response	9	0 Byte

Set HDR	Command ID	Data	Data size
Command	10	0: closed 1: Space HDR 2:Time HDR	1 Byte

	Command ID	Data size
Response	10	0 Byte



Reset	Command ID	Data	Data size
Command	13		0 Byte

	Command ID	Data size
Response	13	0 Byte

Set Frequency	Command ID	Data	Data size
Command	52	0: 12M 1: 6M	1 Byte

	Command ID	Data size
Response	52	0 Byte

Trace Output	Command ID	Data	Data size
Command	209		X Bytes

Version History

Version	Description	Data
V1.0	First Version	20221020
V1.1	Fix and update the parameter	20230510
V1.12	Add accessories information	20230612
V1.2	Update the parameter	20231010
V1.3	Update the parameter	20240407