

CONTACTS	A	B	C	D
09	0.984 [25.00]	1.213 [30.80]	0.642 [16.30]	0.756 [19.20]
15	1.312 [33.32]	1.543 [39.20]	0.969 [24.60]	1.091 [27.70]
25	1.852 [47.04]	2.091 [53.10]	1.508 [38.30]	1.618 [41.10]
37	2.500 [63.50]	2.732 [69.40]	2.157 [54.80]	2.256 [57.30]

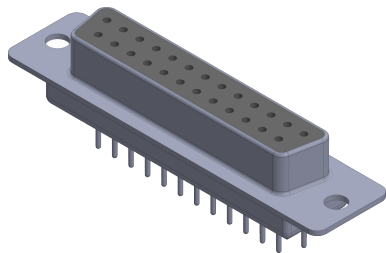
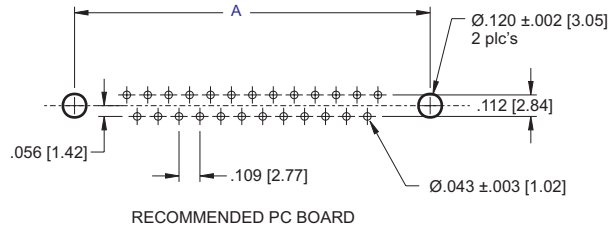
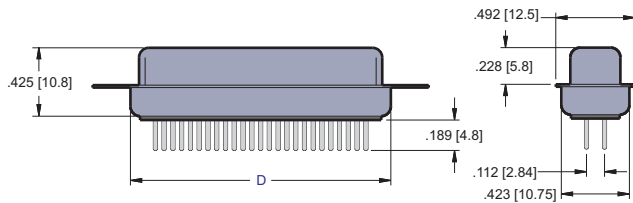
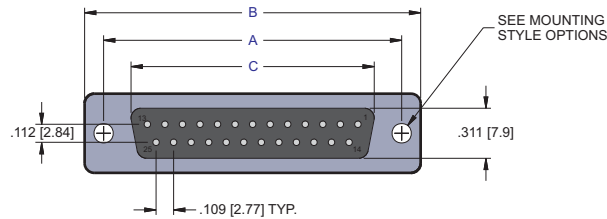

PART NUMBERING

80 XX - 03 S - XX XX - XX

SERIES CODE

NO. OF CONTACTS

09, 15, 25, 37

CONNECTOR TYPE

S = Socket

MOUNTING STYLE OPTIONS

- 01 = .120 Riveted Front and Rear Shell
 - 04 = Riveted #4-40 UNC Open Nut on Rear Shell
 - 05 = Riveted #4-40 UNC Closed Nut on Front Shell
 - 06 = Riveted #4-40 UNC Open Nut on Front Shell
 - 07 = Riveted #4-40 UNC Close Ground Stand Off on Rear Shell
- Consult Factory for other Mounting Options

CONTACT PLATING

- 50µ" Nickel Underplate
- Mating Area Tail
- 05 = Au Flash 100µ" Tin
- 20 = 15µ" Gold 100µ" Tin
- 30 = 30µ" Gold 100µ" Tin

SHELL PLATING

- 50µ" Nickel Underplate
- 1 = Tin Plating (standard)
- 2 = Yellow Chromate

INSULATOR COLOR

- 1 = Black (Standard)
- 2 = White
- 3 = Blue

NOTES:

1. Insulator Material: glass filled thermoplastic nylon 6T UL94V-0 rated.
2. Contact Material: Phosphor Bronze
3. Shell Material: Steel, 100µ" min. Ni.
4. Contact Plating: see part numbering
Clinch nut: Brass, 100µ" min. Ni plated
Screw lock: Brass, 100µ" min. Ni plated
5. Contact Resistance: 20 mOhm max. @ 1 amp DC
6. Insulator Resistance: 1000 MOhm @ 500 VDC
7. Dielectric Withstanding Voltage: 1000 VAC/rms 60Hz for 1 minute.
8. Current Rating: 5 Amp
9. Voltage Rating: 250 VAC/rms 60Hz
10. Insertion Force: Insertion into PCB: 100N max. per contact
11. Withdrawal Force: 30N min. per contact
12. Operating Temperature: -55°C to +125°C
13. Hole Size Requirements:
Drilled Hole Diameter: 0.0473±0.001 [1.20±0.03]
Plating: 0.001- 0.003 [0.030-0.080] copper and
0.0001 to -0.008 [0.003-.020] solder
14. Finished Hole Diameter: 0.043±0.003 [1.09]

ECS	Email:
	custsvc@ecscconn.com
www.ecscconn.com	
Orange County, California	

THIS DRAWING IS SUBJECT TO CHANGE WITHOUT NOTICE.		DRAWN BY: CT	DATE 07.30.04	DESCRIPTION
DIMENSIONS:		CHECKED BY:	8000 SERIES D-SUBMINIATURE SOLDER TAIL, SOCKET	
UNLESS OTHERWISE SPECIFIED: TOLERANCE: .00" ±.008 .000" ±.005 .0000" ±.001		APPROVED BY:		
THIS DRAWING AND SPECIFICATIONS HEREIN, ARE THE PROPERTY OF ECS, AND SHALL NOT BE REPRODUCED OR COPIED OR USED IN WHOLE OR IN PART AS THE BASIS FOR THE MANUFACTURE OR SALE OF ITEMS WITHOUT WRITTEN CONSENT OF ECS, INC.		SIZE A	DRAWING NUMBER: 80XX-03SC	REV. A
SCALE NONE		PATH \\ECS\CUSTOMER PRINTS\8000SER\		SHEET 1 OF 1

8000 D-Subminiature, Mounting Options

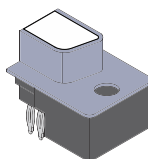
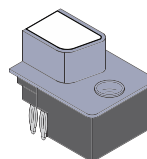
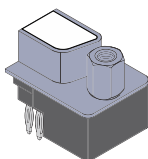
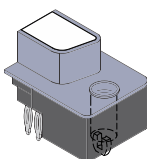
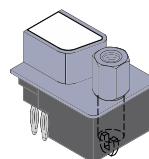

Press-Fit and Plastic Body Connectors

<p>00 = .120 dia. Thru Holes</p> 	<p>02 = #4-40 Threaded Insert</p> 	<p>03 = #4-40 Threaded Insert with #4-40 Screw Lock</p> 	<p>15 = #4-40 Threaded Insert with Board Lock</p> 	<p>16 = #4-40 Screw Lock with Board Lock</p> 
--	---	---	--	--

Solder, Right Angle, and High Density Connectors

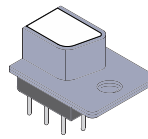
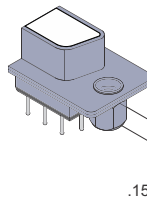
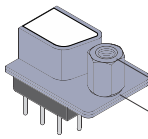
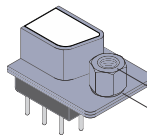
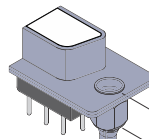
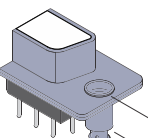
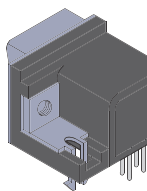
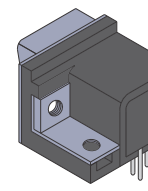
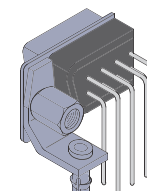
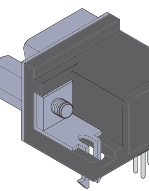
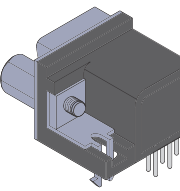
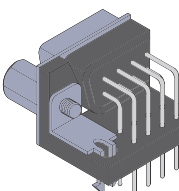
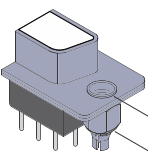
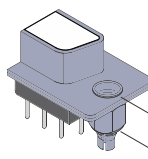
<p>01 = .120 dia. Riveted Front and Rear Shell</p> 	<p>04 = Riveted #4-40 UNC Open Nuts on Rear Shell</p>  <p>.158 [4.0]</p>	<p>05 = Riveted #4-40 UNC Closed Nuts on Front Shell</p>  <p>.228 [5.8]</p>	<p>06 = Riveted #4-40 UNC Open Nuts on Front Shell</p>  <p>.158 [4.0]</p>	<p>07 = Riveted #4-40 UNC Close Ground Stand-Off on Rear Shell (Stamped Contact)</p>  <p>.276 [7.0]</p>
<p>07 = Riveted #4-40 UNC Close Ground Stand-Off on Rear Shell (Machined Contact)</p>  <p>.276 [7.0]</p>	<p>08 = Riveted Ground Hooks with #4-40 UNC Open</p> 	<p>09 = Riveted Ground Tabs with #4-40 UNC Open (Stamped Contact)</p> 	<p>09 = Riveted Ground Tabs with #4-40 UNC Open (Machined Contact)</p> 	<p>10 = Riveted Ground Hooks Pre-Loaded #4-40 UNC Hex Screws</p> 
<p>11 = Assembly Ground Hooks By #4-40 UNC Hex Screws (Stamped Contact)</p> 	<p>11 = Assembly Ground Hooks By #4-40 UNC Hex Screws (Machined Contact)</p> 	<p>12 = Riveted #4-40 UNC Close Ground Stand-Off on Rear Shell (Stamped Contact) for High Profile Connectors</p>  <p>.425 [10.8]</p>	<p>13 = Riveted #4-40 UNC Close Ground Stand-Off on Rear Shell (Stamped Contact)</p>  <p>.354 [8.99]</p>	<p>CONSULT FACTORY FOR OTHER MOUNTING STYLES OPTION</p>