

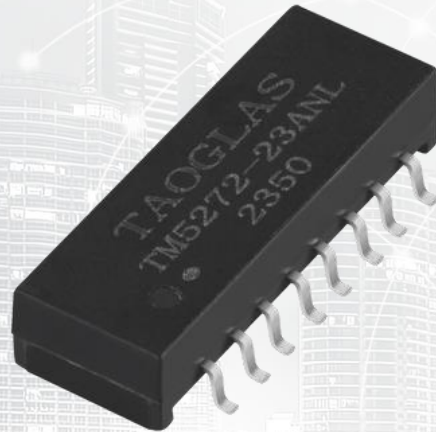

TAOGLAS®



Datasheet

LAN Transformer 10/100 Base-T

Part No:
TM5272-23ANL

Description:

10/100 Base-T Transformer
Single Port and 16pin SMT

Features:

Industrial grade
RX: CMC + Transformer
TX: Transformer + CMC + Auto XFMR
RoHS Compliant

1. Introduction	3
2. Specifications	4
3. Mechanical	5
4. Electrical	6
5. Packaging	7
<hr/>	
Changelog	8

Taoglas makes no warranties based on the accuracy or completeness of the contents of this document and reserves the right to make changes to specifications and product descriptions at any time without notice. Taoglas reserves all rights to this document and the information contained herein. Reproduction, use or disclosure to third parties without express permission is strictly prohibited.



1. Introduction



Featuring a compatible footprint with industry LAN transformers, and designed to work in demanding industrial environmental conditions, the Taoglas TM5272-23ANL is a LAN Transformer 10/100Base-T Single Port of 16pins.

Typical applications for this cost-effective part are:

- Industrial Automation
- Hubs
- Routers
- Switches
- Wireless Access Points

The Taoglas Magnetics Product Team have over fifteen years of LAN magnetics design and high-quality manufacturing. With an ever-expanding portfolio, we provide trusted products and services to customers within a wide range of applications such as: Networking and Interconnect Devices, Servers, Switches, Router, Communication systems and any Digital Consumer electronics.

The Taoglas Exos Series offer an extensive product line of LAN Transformers designed for commercial and industrial grade applications, supporting 10/100 Base-T (Exos100 Series), 1G Base-T (Exos1G Series) and 10G Base-T (Exos10G Series). These products include Single, Dual, and Quad configurations not only for standard applications but also for Power over Ethernet (PoE, PoE+, PoE++).

For more information on the range of products or for assistance with integration, contact your regional Taoglas customer support team.

2. Specifications

Electrical Performance @25°C	
Inductance OCL	350uH MIN @100KHz,0.1V with 8mADC
Turns Ratio (±5%)	1CT: 1CT
Insertion Loss	1-100MHz: -1.0dB MAX
Return Loss	1-30MHz: -18dB MIN
	30-60MHz: -13dB MIN
	60-80MHz: -12dB MIN
Cross talk	1-60MHz: -40dB MIN
	60-100MHz: -35dB MIN
DCRR	1-60MHz: -37dB MIN
	60-100MHz: -28dB MIN
Hi-Pot	1500Vrms

Environmental Specifications	
Operating Temperature	-40°C TO +85°C

Compliance	
RoHS Compliant	
UL recognized - FILE NO. E528697	
IEEE 802.3	

Storage requirements	
Humidity	MSL - 1
Storage Temperature	-40°C TO +85°C

3. Mechanical

3.1 Mechanical Drawings

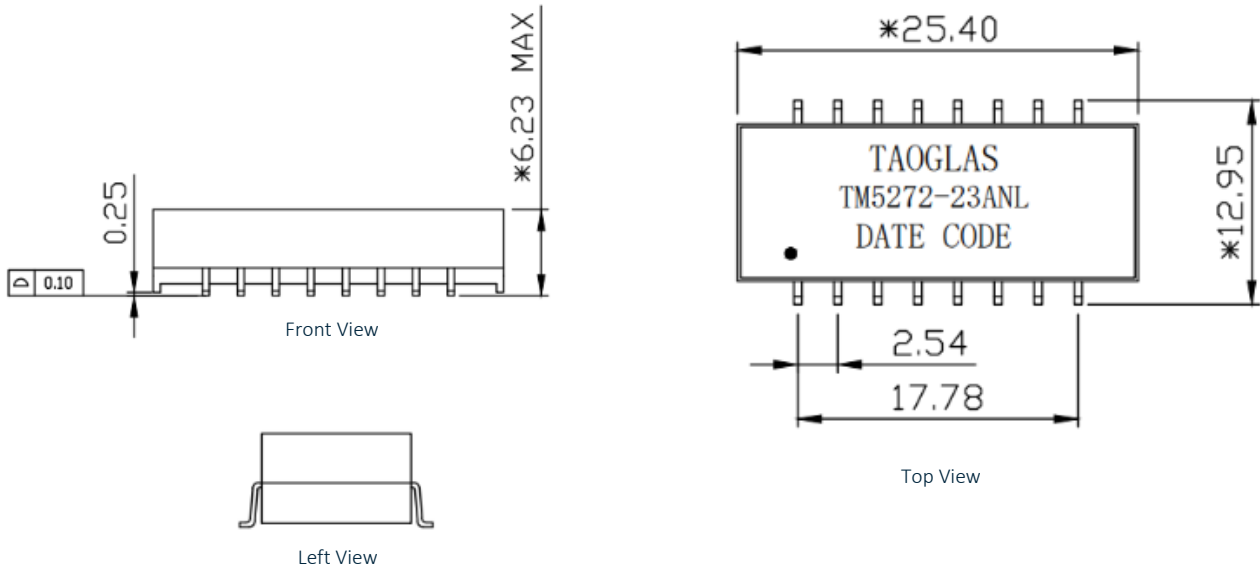

Mechanical Specifications	
Length	25.4 mm
Width	12.95 mm
Height	6.23 mm
Weight	1.52 g
Mounting Style	Surface Mount (SMT)

Dimensions are in millimeters with the following tolerances: X.XX = ± 0.25

3.2 Pad Layout

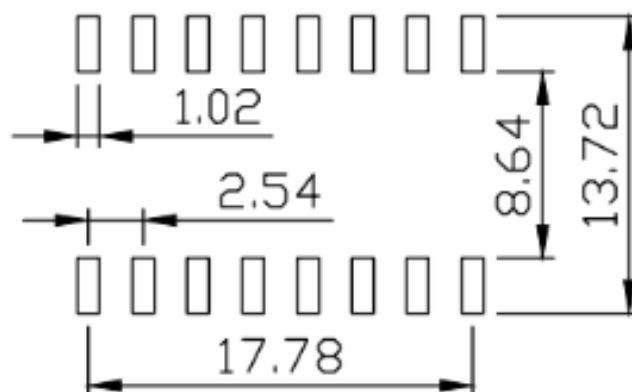

Suggested pad layout

Dimensions are in millimeters with the following tolerances: X.XX = ± 0.10

4. Electrical

4.1 Electrical Drawings

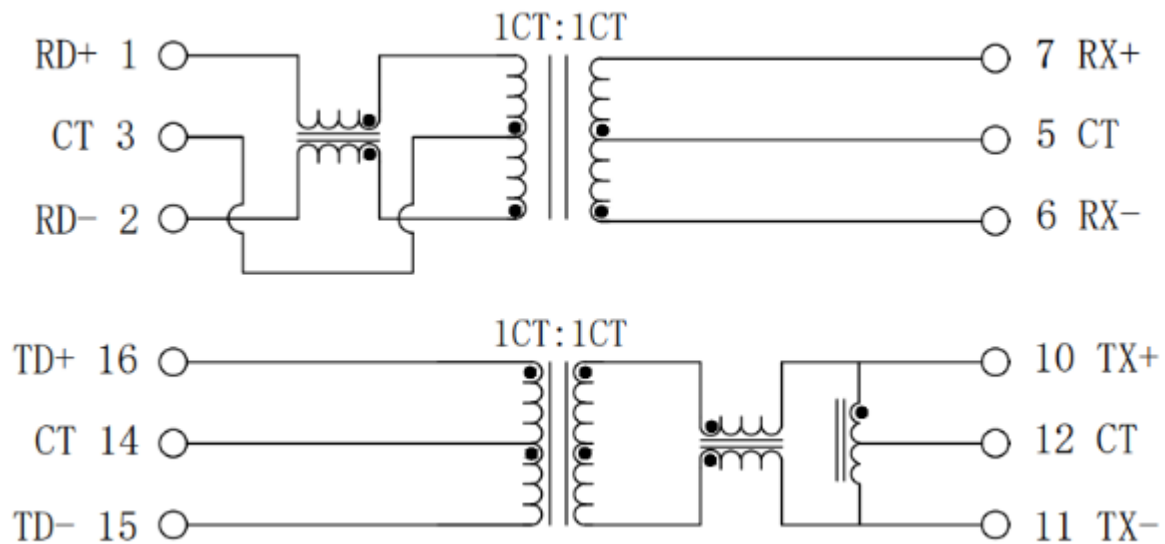

4.2 Profile of Reflow Solder

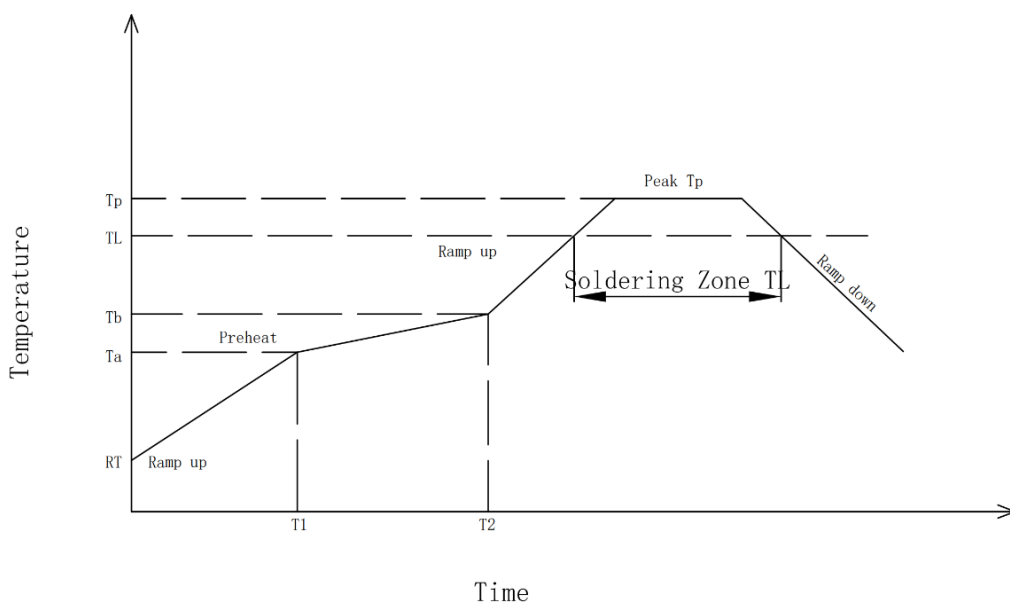

Preheat :
Temperature (Ta-Tb):150-200°C
Time(T1-T2):60-180s

Holding Temperature:217°C
Time (TL):60-150s

Max Temperature (Tp):250°C
Max Time (Tp):5s

The average speed:3°C/S Max
The average cooling speed:6°C/S Max

From 25°C to Products out of the
furnace:6 minutes Max

5. Packaging

5.1 SPQ

1 reel = 400 pcs

Reel (mm) = 44x13.6x20.2

Weight = 1.2 kg

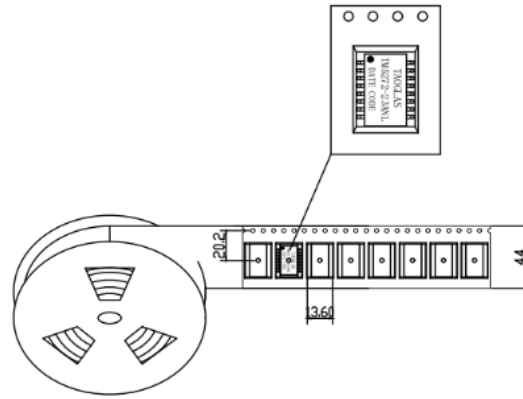

5.2 Carton

1 Carton = 4 reels = 1600 pcs

Carton dimensions: 360*360*250 mm

Carton Weight: 5.7 kg



5.3 Label

Taoglas Limited	
P/N NO: XXXXXXXX	
QYT: XXX PCS	DC: XXXX
DATE: XXXX-XX-XX	

SPQ Label (8x4cm)

Taoglas Limited	
P/N NO: XXXXXXXX	
PO: XXXXXXXX	B/N: XXXXXXXX
QYT: XXX PCS	DC: XXXX
DATE: XXXX-XX-XX	

Carton Label (8x4cm)

Changelog

Changelog for the datasheet

SPE-23-8-376 – TM5272-23ANL

Revision: A (Original First Release)

Date:	2024-01-01
Notes:	
Author:	Javier Vasena

Previous Revisions



www.taoglas.com

