

THIS DRAWING CONTAINS INFORMATION PROPRIETARY TO RF INDUSTRIES.  
 ANY UNAUTHORIZED USE OF THIS DRAWING IS EXPRESSLY PROHIBITED  
 WITHOUT WRITTEN PERMISSION FROM RF INDUSTRIES.  
 ANY VIOLATION IS PUNISHABLE UNDER U.S. COPYRIGHT LAWS.

ALL DIMENSIONS ARE REFERENCE ONLY

PART NO.

**RFU-600-1C1**

REV	DESCRIPTION	DWN	DATE	APPROVED
A	ENGINEERING RELEASE	CZS	8/8/97	R. RICE
B	CHANGE CABLE LISTING / UPDATE CONN. DIMS & DWG. FORMAT	CZS	7/26/00	JDMc

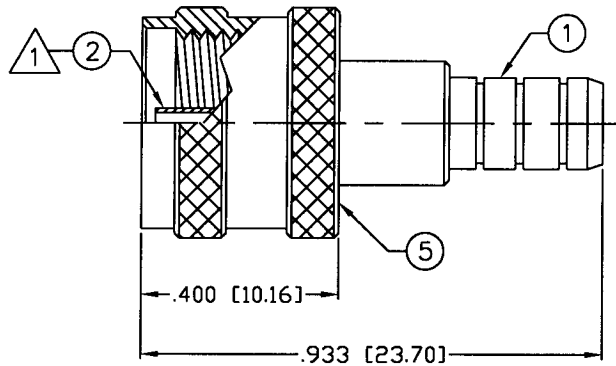

1 RECOMENED CRIMP DIE: .052"

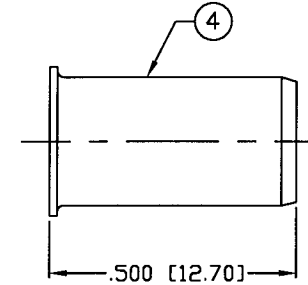

RECOMENED CRIMP DIE: .213"

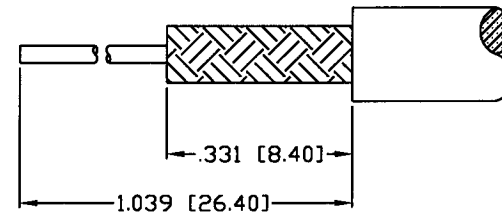

RECOMENED STRIPPING INSTRUCTIONS

**SPECIFICATIONS:**

IMPEDANCE: 50 Ohms  
 FREQUENCY RANGE: 0-2.5 GHz  
 WORKING VOLTAGE: 335 V rms Max. @ Sea Level  
 VSWR MAX: 1.25  
 FOR RG-55, 55A, 55B, 142, 142A, 142B, 223 & 400/U,  
 ALPHA 9055, 9055B, 9223, BELDEN 8219, 83242, 84142

1	BODY	1	BRASS	NICKEL, 100μ"	000486	
2	CONTACT	1	BRASS	GOLD, 3μ"		
3	INSULATOR	1	DELRIIN	---		
4	FERRULE	1	BRASS	NICKEL, 100μ"		
5	SHELL	1	BRASS	NICKEL, 100μ"		
6						
7						
8						
9						
10						
11						
12						
13						
14						
#	DESCRIPTION	QTY	MATERIAL	FINISH	APPROVALS	DATE

UNLESS OTHERWISE SPECIFIED:  
 1. REMOVE ALL BURRS  
 2. BREAK ALL CORNERS & EDGES .005 R. MAX.  
 3. CHAMFER 1ST & LAST THREADS 45°  
 4. SURFACE ROUGHNESS 63 FINISH MIL-STD-10  
 5. DIAMETERS ON COMMON CENTERS TO BE CONCENTRIC WITHIN .002 T.I.R.  
 6. ALL DIMENSIONS ARE AFTER PLATING.

DIMENSIONS ARE IN INCHES AND [MILLIMETERS]  
 UNLESS OTHERWISE NOTED TOLERANCES ARE:  
 DECIMALS DIAMETER  
 .XXX±.003 [.08] .XXX±.001 [.03]  
 .XX±.005 [.13] .XX±.003 [.08]

DRAWN C. ZUNIGA 2/25/03  
 CHECKED [Signature] 2-25-03  
 ORJ DRAWN C. ZUNIGA 8/8/97

**RF connectors**  
 DIVISION OF RF INDUSTRIES, LTD.

7610 MIRAMAR RD  
 SAN DIEGO, CA 92126  
 (858) 549-6340  
 (858) 549-6345 FAX

**MINI UHF PLUG, CRIMP**

SIZE	CABLE GROUP	DWG NO.	REV
A	C1	RFU-600-1C1	B
SCALE:	NTS	CAD FILE	OUTLINE
SHEET 1 OF 1			