

## General Description



The BDE-MB1354P102 is a multi-band Sub-1GHz and 2.4GHz wireless module supporting Thread, Zigbee®, Bluetooth® 5.2 low Energy, IEEE 802.15.4g, IPv6-enabled smart objects (6LoWPAN), mioty, Wi-SUN, Amazon Sidewalk, proprietary systems including TI 15.4-Stack (Sub-1GHz and 2.4GHz), and concurrent multiprotocol through a Dynamic Multiprotocol Manager (DMM) driver. The module is optimized for low-power wireless communication and advanced security features in building security systems, HVAC, smart meters, medical, wired networking, portable electronics, home theater & entertainment markets and connected peripherals markets.

The BDE-MB1354P102 module is embedded with a powerful 48-MHz Arm® Cortex®-M33 processor with TrustZone® based secure key storage, device ID and trusted functions. The module has a low standby current of 0.98  $\mu$ A with full 256 KB RAM retention, which enables longer battery life wireless applications. With its integrated PA, the module supports +20 dBm output power with best-in-class transmit current consumption at 101 mA for 2.4-GHz operation. This is suitable for the long-range and low-power applications. It is featured with the Low SER (Soft Error Rate) FIT (Failure-in-time) for long operational lifetime with no disruption for industrial markets with always-on SRAM parity against corruption due to potential radiation events. The device also has an autonomous ultra-low power Sensor Controller CPU with fast wake-up capability. As an example, the sensor controller is capable of 1-Hz ADC sampling at 1- $\mu$ A system current.

The module has a software defined radio powered by an Arm® Cortex® M0 which allows support for multiple physical layers and RF standards. PHY and frequency switching can be done runtime through a dynamic multiprotocol manager (DMM) driver. The module supports +14 dBm TX at 25.8 mA in the Sub-1GHz band and +20 dBm TX at 101 mA in the 2.4-GHz band. It has a receive sensitivity of -104 dBm for 125-kbps Bluetooth® Low Energy Coded PHY.

The module integrates all required system-level hardware components including clocks, balun filter, other passives, and PCB trace antenna or U.FL connector into a small PCB form factor. It is for easy assembly and low-cost PCB design.

The module is pre-certified with FCC, ISED, CE and Bluetooth SIG to make easy integration and fast time-to-market for customers.

In order to fulfill different application scenarios, we provide different variants for users:

- BDE-MB1354P102NN32 –with RFOUT pad for Sub-1GHz and for 2.4GHz antenna, with on-module 32-Mbit SPI flash
- BDE-MB1354P102NU32 –with RFOUT pad for Sub-1GHz and integrated U.FL connector for 2.4GHz antenna, with on-module 32-Mbit SPI flash
- BDE-MB1354P102NA32 –with RFOUT pad for Sub-1GHz antenna and integrated PCB trace antenna for 2.4GHz, with on-module 32-Mbit SPI flash
- BDE-MB1354P102UN32 –with integrated U.FL connector for Sub-1GHz and RFOUT pad for 2.4GHz antenna, with on-module 32-Mbit SPI flash
- BDE-MB1354P102UU32 –with integrated U.FL connector for Sub-1GHz and for 2.4GHz antenna, with on-module 32-Mbit SPI flash

- BDE-MB1354P102UA32 –with integrated U.FL connector for Sub-1GHz antenna and integrated PCB trace antenna for 2.4GHz, with on-module 32-Mbit SPI flash
- BDE-MB1354P102NN0 –with RFOUT pad for Sub-1GHz and for 2.4GHz antenna, without on-module 32-Mbit SPI flash
- BDE-MB1354P102NU0 –with RFOUT pad for Sub-1GHz and integrated U.FL connector for 2.4GHz antenna, without on-module 32-Mbit SPI flash
- BDE-MB1354P102NA0 –with RFOUT pad for Sub-1GHz antenna and integrated PCB trace antenna for 2.4GHz, without on-module 32-Mbit SPI flash
- BDE-MB1354P102UN0 –with integrated U.FL connector for Sub-1GHz and RFOUT pad for 2.4GHz antenna, without on-module 32-Mbit SPI flash
- BDE-MB1354P102UU0 –with integrated U.FL connector for Sub-1GHz and for 2.4GHz antenna, without on-module 32-Mbit SPI flash
- BDE-MB1354P102UA0 –with integrated U.FL connector for Sub-1GHz antenna and integrated PCB trace antenna for 2.4GHz, without on-module 32-Mbit SPI flash

## Key Features

### ■ Wireless microcontroller

- Powerful 48-MHz Arm® Cortex®- M33 processor with TrustZone®
- FPU and DSP extension
- 1024 KB flash program memory
- 8 KB of cache SRAM
- 256 KB of ultra-low leakage SRAM with parity for high-reliability operation
  - ✧ 32 kB of additional SRAM is available if parity is disabled
- Dual-band Sub-1GHz and 2.4GHz operation
- Dynamic multiprotocol manager (DMM) driver
- Programmable radio includes support for 2-(G)FSK, 4-(G)FSK, MSK, OOK, IEEE 802.15.4 PHY and MAC
- Supports over-the-air upgrade (OTA)

### ■ Ultra-low power sensor controller

- Autonomous MCU with 4 KB of SRAM
- Sample, store, and process sensor data
- Fast wake-up for low-power operation
- Software defined peripherals, capacitive touch, flow meter, LCD

### ■ Low power consumption

- MCU consumption:
  - ✧ 3.4 mA active mode, CoreMark®
  - ✧ 71 µA/MHz running CoreMark®
  - ✧ 0.98 µA standby mode, RTC, 256 KB RAM
  - ✧ 0.17 µA shutdown mode, wake-up on pin
- Ultra low-power sensor controller consumption:
  - ✧ 32 µA in 2 MHz mode
  - ✧ 849 µA in 24 MHz mode

### ➤ Radio Consumption:

- ✧ 5.8 mA RX at 868 MHz
- ✧ 6.9 mA RX at 2.4 GHz
- ✧ 25.8 mA TX at +14 dBm at 868 MHz
- ✧ 101 mA TX at +20 dBm at 2.4 GHz

### ■ Wireless protocol support

- Thread, Zigbee®, Matter
- Bluetooth® 5.2 Low Energy
- Wi-SUN
- Mioty
- Amazon Sidewalk
- Wireless M-Bus
- SimpleLink™ TI 15.4-stack (Sub-1GHz)
- 6LoWPAN
- Proprietary systems

### ■ High performance radio

- Up to 130 dB link budget at 50 kbps, 868 MHz
- Up to 141 dB link budget at 2.5 kbps, 868 MHz
- –121 dBm for 2.5 kbps long-range mode
- –110 dBm at 50 kbps, 802.15.4, 868 MHz
- –104 dBm for Bluetooth® Low Energy 125 kbps
- –105 dBm for IEEE 802.15.4-2006 2.4 GHz OQPSK (coherent modem)
- Output power up to +20 dBm with temperature compensation

### ■ Regulatory compliance (On-going)

- FCC
- IC
- CE-RED
- Bluetooth SIG

### ■ MCU peripherals

- Most digital peripherals can be routed to any GPIO
- Four 32-bit or eight 16-bit general-purpose timers
- 12-bit SAR ADC, 200 ksps, 8 channels
- 8-bit DAC
- Two comparators
- Programmable current source
- Four UART, four SPI, two I<sup>2</sup>C, I<sup>2</sup>S
- Real-time clock (RTC)
- Integrated temperature and battery monitor
- 24 GPIOs – none SPI flash versions
- 20 GPIOs – SPI flash versions
- **Security enablers**
  - Supports secure boot
  - Supports secure key storage and device ID
  - Arm® TrustZone® for trusted execution environment
  - AES 128- and 256-bit cryptographic accelerator
  - Public key accelerator
  - SHA2 Accelerator (full suite up to SHA-512)
  - True random number generator (TRNG)
  - Secure debug lock
  - Software anti-rollback protection
- **Operating range**
  - On-chip buck DC/DC converter
  - 1.8 V to 3.8 V single supply voltage
  - 2.3 V to 3.6 V single supply voltage (SPI flash variants)
- -40 to +85°C
- **Antenna**
  - PCB trace antenna for 2.4 GHz :  
BDE-MB1354P102NA  
BDE-MB1354P102UA
  - U.FL connector for Sub-1GHz :  
BDE-MB1354P102UN  
BDE-MB1354P102UU  
BDE-MB1354P102UA
  - U.FL connector for 2.4 GHz :  
BDE-MB1354P102NU  
BDE-MB1354P102UU  
BDE-MB1354P102UN
  - ANT Pad for Sub-1GHz :  
BDE-MB1354P102NN  
BDE-MB1354P102NU  
BDE-MB1354P102NA
  - ANT Pad for 2.4 GHz :  
BDE-MB1354P102NN  
BDE-MB1354P102UN
- **On-Module SPI Flash**
  - 32-Mbit, only available in SPI flash versions
- **Package**
  - Dimension: 26 mm x 19 mm x 2.15 mm
  - LCC-42
  - RoHS-compliant package

## Applications

- 315, 433, 470 to 510, 868, 902 to 928, and 2400 to 2480 MHz ISM and SRD systems with down to 4 kHz of receive bandwidth
- Building automation
  - Building security systems – motion detector, electronic smart lock, door and window sensor, garage door system, gateway
  - HVAC – thermostat, wireless environmental sensor, HVAC system controller, gateway
  - Fire safety system – smoke and heat detector, fire alarm control panel (FACP)
  - Video surveillance – IP network camera
  - Elevators and escalators – elevator main control panel for elevators and escalators
- Grid infrastructure
  - Smart meters – water meter, gas meter, electricity meter, and heat cost allocators
  - Grid communications – wireless communications – Long-range sensor applications
  - Other alternative energy – energy harvesting
- Industrial transport – asset tracking
- Factory automation and control
- Medical
- Communication equipment
  - Wired networking – wireless LAN or Wi-Fi access points, edge router
- Personal electronics
  - Home theater & entertainment – smart speakers, smart display, set-top box
  - Wearables (non-medical) – smart trackers, smart clothing

## Contents

General Description .....	1
Key Features .....	2
Applications.....	4
Contents .....	5
1. References .....	6
2. Block Diagram .....	7
3. Terminal Configuration and Functions .....	8
3.1 Pin Diagram .....	8
3.2 Pin Attributes and Pin Multiplexing.....	8
4. Specifications .....	10
4.1 Absolute Maximum Ratings .....	10
4.2 Recommended Operating Conditions .....	10
5. Mechanical Specifications.....	11
5.1 Dimensions.....	11
5.2 PCB Footprint .....	11
5.3 Marking .....	12
6. Typical Reflow Profile .....	13
7. Ordering Information .....	14
8. Revision History .....	14
Important Notice and Disclaimer .....	15
Contact .....	15

## 1. References

- [1] CC1354P10 resources: <https://www.ti.com/product/CC1354P10>

## 2. Block Diagram

BDE-MB1354P102 module is based on the Texas Instruments CC1354P10 single chip wireless MCU. The module integrates all required system-level hardware components including clocks, balun filter, other passives, and PCB trace antenna or U.FL connector into a small PCB form factor.

The module, as seen in Figure 1 and Figure 2, comprises of:

- 48-MHz XTAL
- 32.768-kHz XTAL
- Power inductors and capacitors
- Pull-up resistor
- Passive balun filter
- Decoupling capacitors
- Matching circuit
- PCB trace antenna (BDE-MB1354P102XA)
- U.FL connector (BDE-MB1354P102XU/BDE-MB1354P102UX)

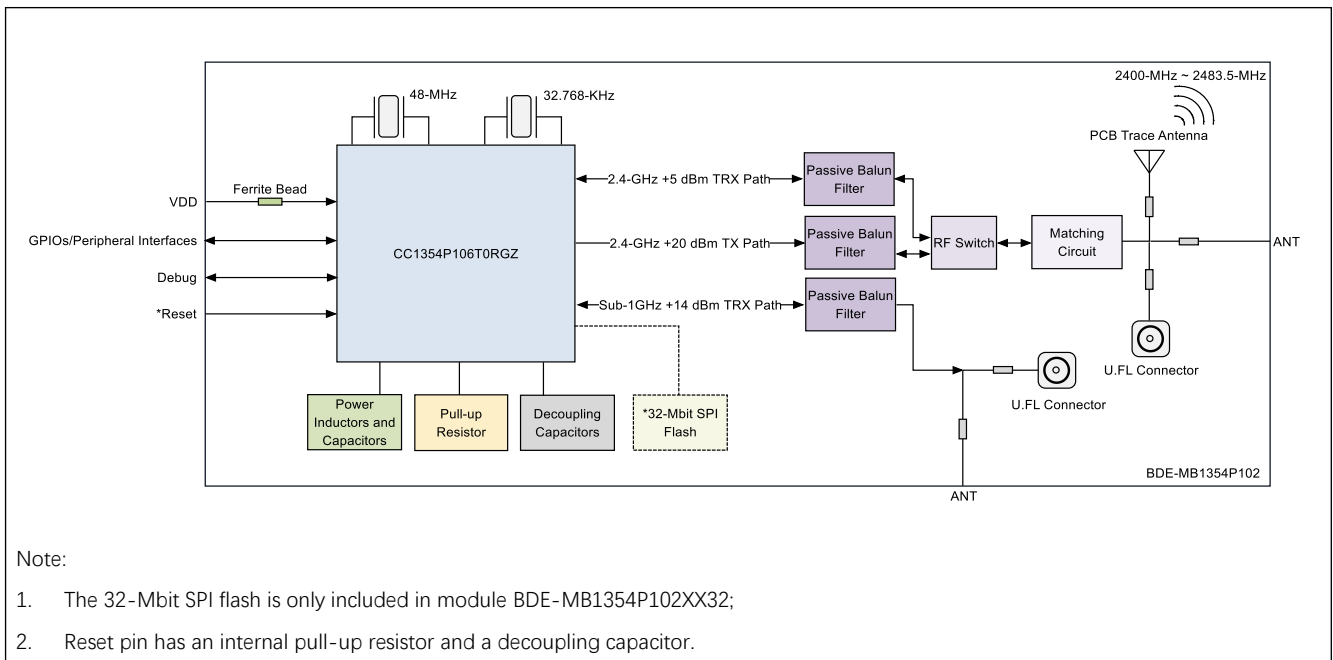

Figure 1. BDE-MB1354P102 Module Block Diagram

### 3. Terminal Configuration and Functions

#### 3.1 Pin Diagram

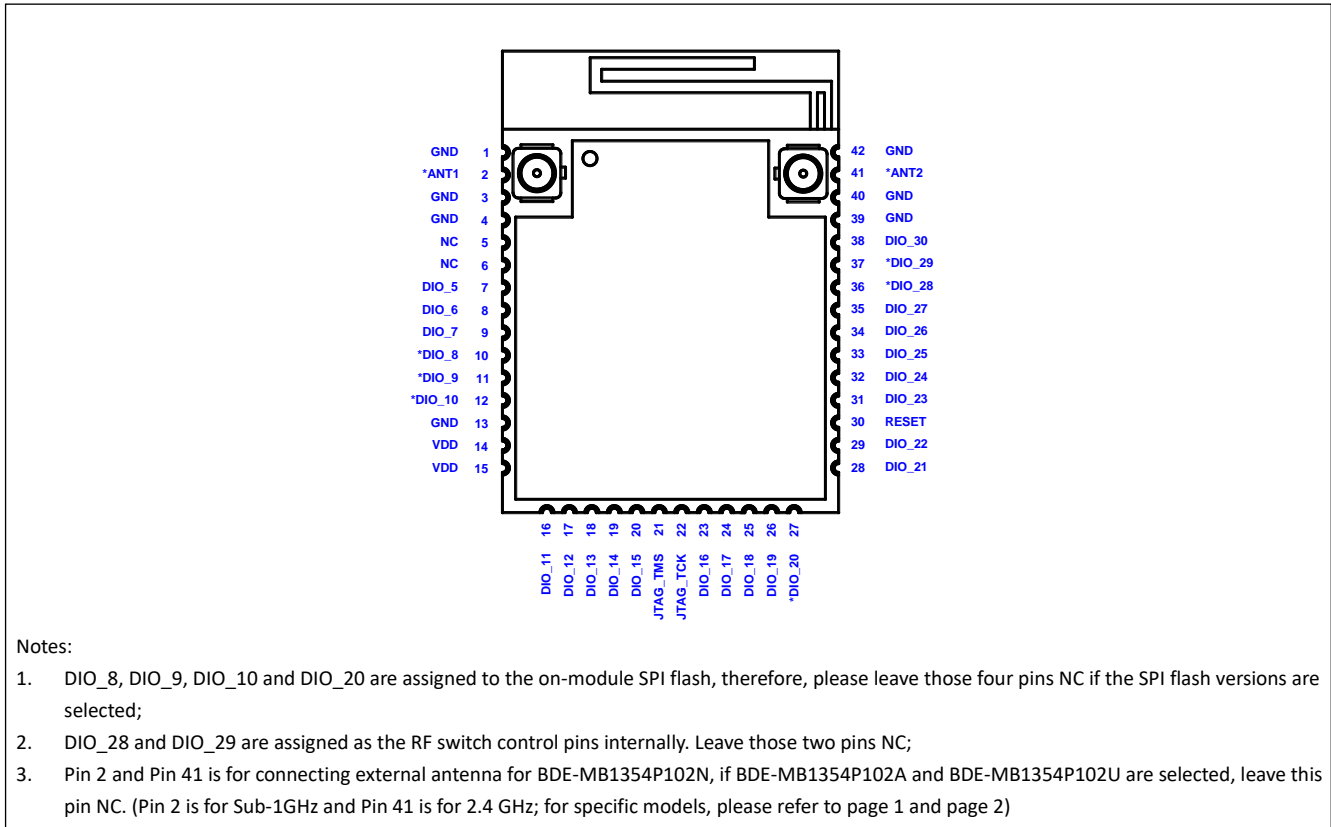

Figure 2. Pin Diagram of BDE-MB1354P102 (Top View)

#### 3.2 Pin Attributes and Pin Multiplexing

Table 1 describes the definitions of the pins of the module.

Table 1. Pin Description <sup>(1)</sup>

Module Pin #	Pin Name	Type	Description
1	GND	Ground	Power ground
2	ANT1	RF	Antenna port for Sub-1GHz
3	GND	Ground	Power ground
4	GND	Ground	Power ground
5	NC	-	No connect
6	NC	-	No connect
7	DIO_5	I/O	GPIO, high-drive capability
8	DIO_6	I/O	GPIO, high-drive capability
9	DIO_7	I/O	GPIO, high-drive capability
10	DIO_8	I/O	GPIO, assigned as SPI_MISO of on-module SPI flash in BDE-MB1354P102XX32
11	DIO_9	I/O	GPIO, assigned as SPI_MOSI of on-module SPI flash in BDE-MB1354P102XX32
12	DIO_10	I/O	GPIO, assigned as SPI_SCLK of on-module SPI flash in BDE-MB1354P102XX32
13	GND	Ground	Power ground
14	VDD	Power	Power supply
15	VDD	Power	Power supply
16	DIO_11	I/O	GPIO



Module Pin #	Pin Name	Type	Description
17	DIO_12	I/O	GPIO
18	DIO_13	I/O	GPIO
19	DIO_14	I/O	GPIO
20	DIO_15	I/O	GPIO
21	JTAG_TMSC	I/O	JTAG TMSC, high-drive capability
22	JTAG_TCKC	I	JTAG TCKC
23	DIO_16	I/O	GPIO, JTAG_TDO, high-drive capability
24	DIO_17	I/O	GPIO, JTAG_TDI, high-drive capability
25	DIO_18	I/O	GPIO
26	DIO_19	I/O	GPIO
27	DIO_20	I/O	GPIO, assigned as SPI_CS of on-module SPI flash in BDE-MB1354P102XX32
28	DIO_21	I/O	GPIO
29	DIO_22	I/O	GPIO
30	RESET	I	Reset, active low, 100K ohm internal pull-up resistor
31	DIO_23	I/O	GPIO, analog capability
32	DIO_24	I/O	GPIO, analog capability
33	DIO_25	I/O	GPIO, analog capability
34	DIO_26	I/O	GPIO, analog capability
35	DIO_27	I/O	GPIO, analog capability
36	DIO_28	I/O	GPIO, analog capability, assigned as RF switch control pin, leave NC
37	DIO_29	I/O	GPIO, analog capability, assigned as RF switch control pin, leave NC
38	DIO_30	I/O	GPIO, analog capability
39	GND	Ground	Power ground
40	GND	Ground	Power ground
41	ANT2	RF	Antenna port for 2.4 GHz
42	GND	Ground	Power ground

Note <sup>(1)</sup>: For more information, please refer to [CC1354P10](#) datasheet;

## 4. Specifications

### 4.1 Absolute Maximum Ratings

Stresses beyond those listed under Absolute Maximum Ratings may cause permanent damage to the device. These are stress ratings only, so functional operation of the device at these or any other conditions beyond those indicated in the operational sections of the specification are not implied. Exposure to Absolute Maximum Rating conditions for extended periods may affect device reliability.

**Table 2. Absolute Maximum Ratings**

PARAMETER	MIN	MAX	UNIT	Notes
VDD	-0.3	4.1	V	
Voltage on any digital pins	-0.3	VDD+0.3≤4.1	V	
Voltage on ADC input	-0.3	VDDS	V	Voltage scaling enabled
	-0.3	1.49	V	Voltage scaling disabled, internal reference
	-0.3	VDD/2.9	V	Voltage scaling disabled, VDD as reference
Storage temperature	-40	150	°C	

### 4.2 Recommended Operating Conditions

**Table 3. Recommended Operating Conditions**

PARAMETER	MIN	TYP	MAX	UNIT
VDD	1.8	3.3	3.8	V
VDD (For SPI flash variants)	2.3	3.3	3.8	V
Operating temperature	-40	-	85	°C
Rising supply voltage slew rate	0		100	mV/us
Falling supply voltage slew rate	0		20	mV/us

### 5. Mechanical Specifications

#### 5.1 Dimensions

The following pages include mechanical, footprint drawings, and marking information. This information is the most current data available for the designated devices.

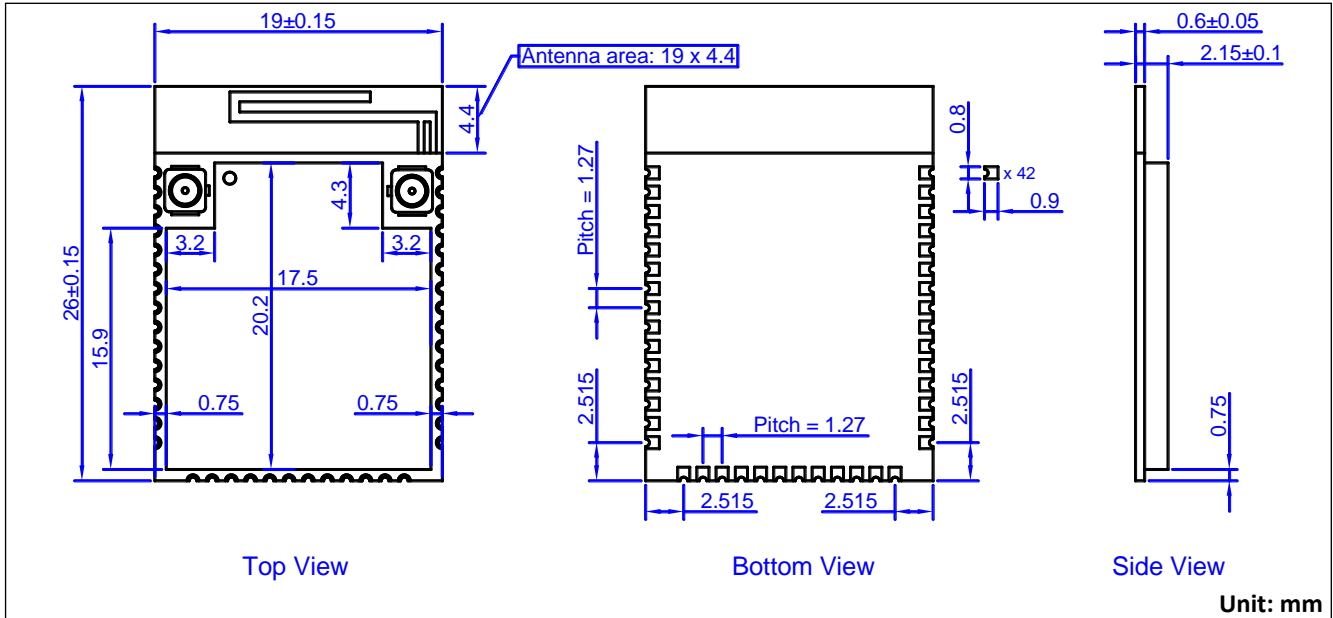
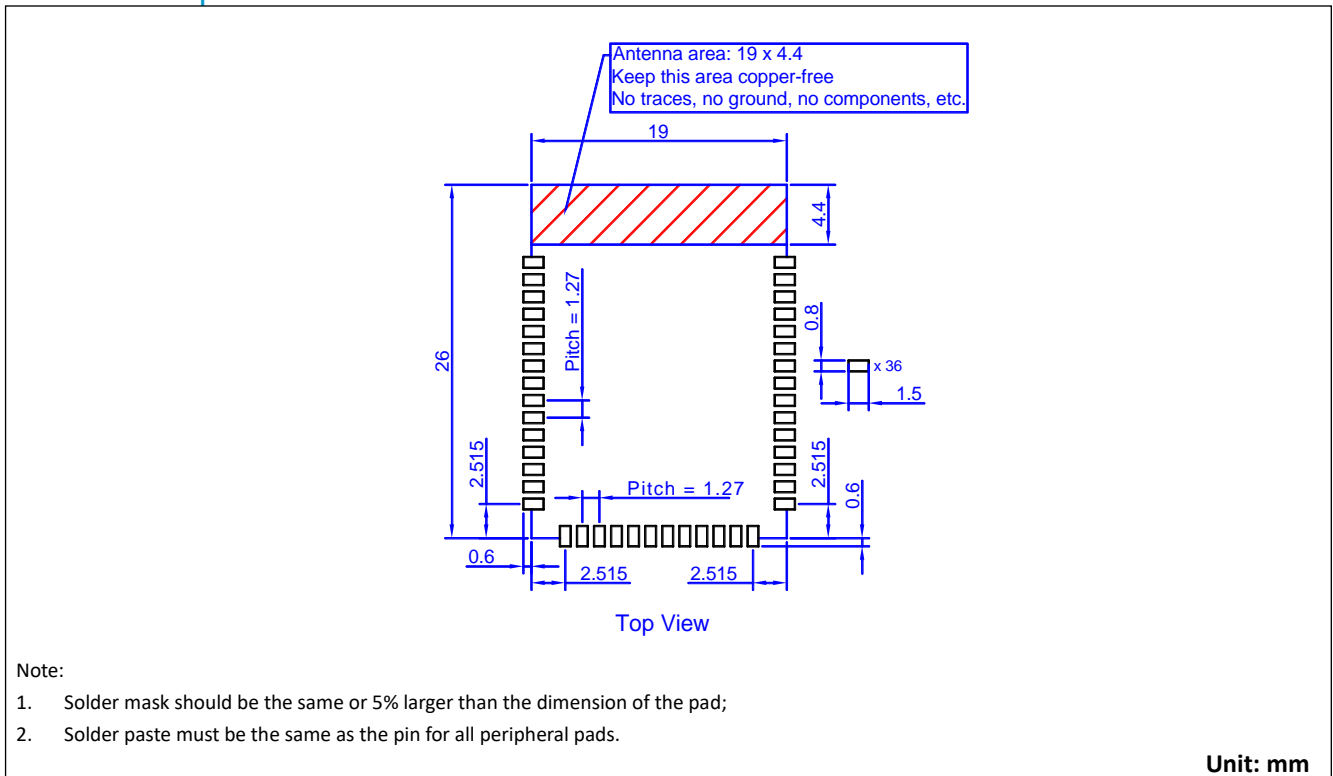

Figure 3. Mechanical Drawing of BDE-MB1354P102

#### 5.2 PCB Footprint



Note:

- Solder mask should be the same or 5% larger than the dimension of the pad;
- Solder paste must be the same as the pin for all peripheral pads.

Unit: mm

Figure 4. Recommended Module Footprint of BDE-MB1354P102

5.3 Marking

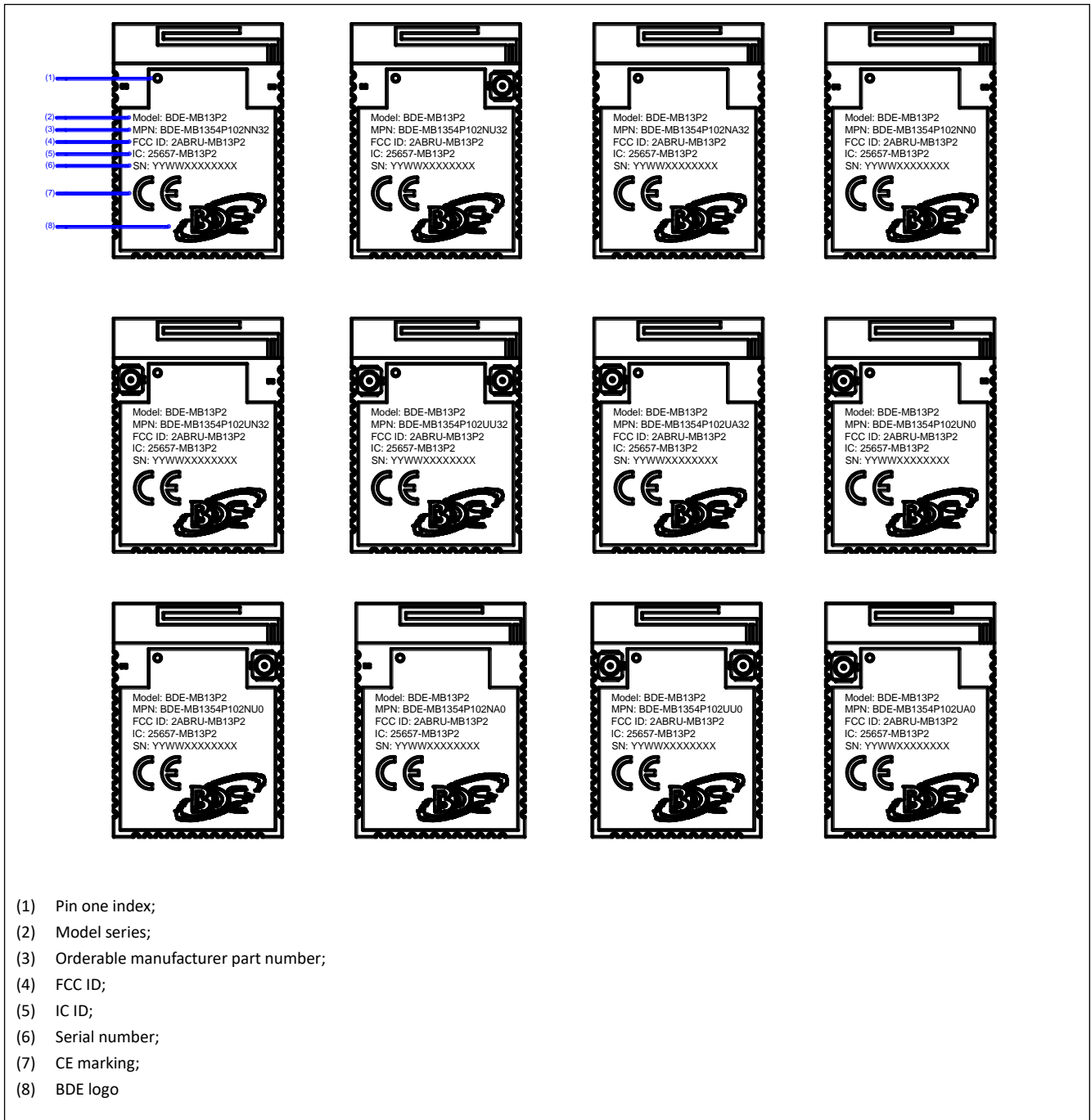

Figure 5. Module Marking

## 6. Typical Reflow Profile

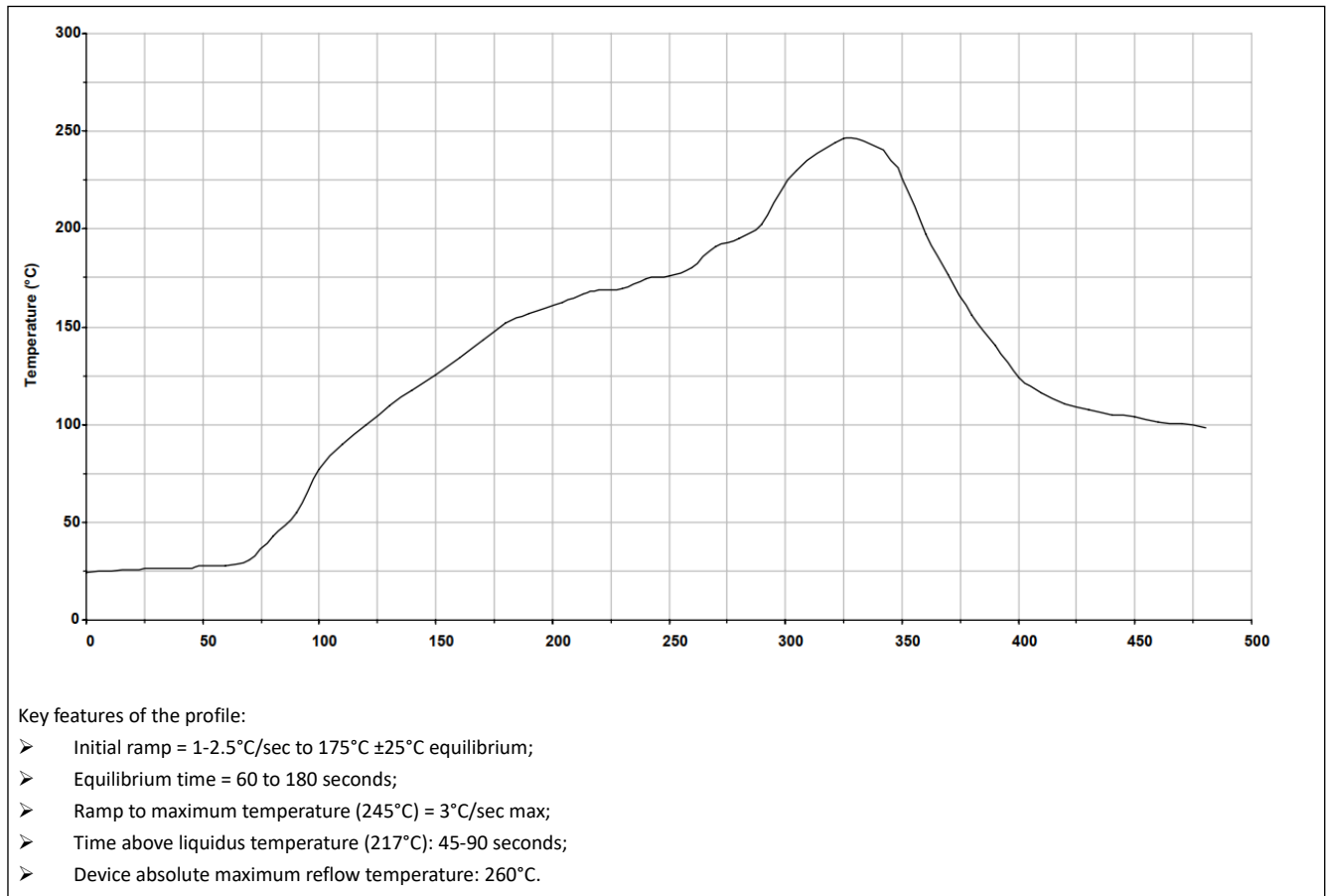

Figure 6. Typical Reflow Profile

## 7. Ordering Information

Part Number	Size (mm)	Core Chip	Shipping Form	MOQ
BDE-MB1354P102NN32	26 × 19 × 2.15	CC1354P106TORGZ	Tape & Reel	1K
BDE-MB1354P102NU32	26 × 19 × 2.15	CC1354P106TORGZ	Tape & Reel	1K
BDE-MB1354P102NA32	26 × 19 × 2.15	CC1354P106TORGZ	Tape & Reel	1K
BDE-MB1354P102UN32	26 × 19 × 2.15	CC1354P106TORGZ	Tape & Reel	1K
BDE-MB1354P102UU32	26 × 19 × 2.15	CC1354P106TORGZ	Tape & Reel	1K
BDE-MB1354P102UA32	26 × 19 × 2.15	CC1354P106TORGZ	Tape & Reel	1K
BDE-MB1354P102NNO	26 × 19 × 2.15	CC1354P106TORGZ	Tape & Reel	1K
BDE-MB1354P102NU0	26 × 19 × 2.15	CC1354P106TORGZ	Tape & Reel	1K
BDE-MB1354P102NA0	26 × 19 × 2.15	CC1354P106TORGZ	Tape & Reel	1K
BDE-MB1354P102UN0	26 × 19 × 2.15	CC1354P106TORGZ	Tape & Reel	1K
BDE-MB1354P102UU0	26 × 19 × 2.15	CC1354P106TORGZ	Tape & Reel	1K
BDE-MB1354P102UA0	26 × 19 × 2.15	CC1354P106TORGZ	Tape & Reel	1K

## 8. Revision History

Revision	Date	Description
V0.1	8-April-2024	Preliminary, draft

The latest datasheet can be found with this [link](#).

## Important Notice and Disclaimer

The information contained herein is believed to be reliable. BDE makes no warranties regarding the information contained herein. BDE assumes no responsibility or liability whatsoever for any of the information contained herein. BDE assumes no responsibility or liability whatsoever for the use of the information contained herein. The information contained herein is provided "AS IS, WHERE IS" and with all faults, and the entire risk associated with such information is entirely with the user. All information contained herein is subject to change without notice. Customers should obtain and verify the latest relevant information before placing orders for BDE products. The information contained herein or any use of such information does not grant, explicitly or implicitly, to any party any patent rights, licenses, or any other intellectual property rights, whether with regard to such information itself or anything described by such information.

### Contact

BDE Technology Inc.

USA: 67 E Madison St, # 1603A, Chicago, IL 60603, US

Tel: +1-312-379-9589

Website: <http://www.bdecomm.com>

Email: [info@bdecomm.com](mailto:info@bdecomm.com)

China: B2-403, 162 Science Avenue, Huangpu District, Guangzhou 510663, China

Tel: +86-20-28065335

Website: <http://www.bdecomm.com>

Email: [shu@bdecomm.com](mailto:shu@bdecomm.com)