



**WINSTAR Display Co.,Ltd.**  
**華凌光電股份有限公司**



# Winstar Display Co., LTD

## 華凌光電股份有限公司



WEB: <https://www.winstar.com.tw> E-mail: sales@winstar.com.tw

### SPECIFICATION

**CUSTOMER :** \_\_\_\_\_

**MODEL NO. :** WLOF00043000WGDAASA00

<p style="text-align: center;"><b>APPROVED BY:</b></p> <p style="text-align: center;">( FOR CUSTOMER USE ONLY )</p>	
---	--

SALES BY	APPROVED BY	CHECKED BY	PREPARED BY
		Hedy Lai	Jason Chan

VERSION	DATE	REVISED PAGE NO.	SUMMARY
E	2024/02/07	11	Revise CN1 Pin 4&8 to Input

TFT Display Inspection Specification: <https://www.winstar.com.tw/technology/download.html>

Precaution in use of TFT module: <https://www.winstar.com.tw/technology/download/declaration.html>

<b>RECORDS OF REVISION</b>			<b>DOC. FIRST ISSUE</b>
<b>VERSION</b>	<b>DATE</b>	<b>REVISED PAGE NO.</b>	<b>SUMMARY</b>
A	2022/04/08		First issue
B	2022/04/15	8 9 15	Update Contour drawing Add PCBA Part number Add description of default selection
C	2023/09/11	9	Add note in 6.Electrical Characteristics
D	2023/09/18	6 7 9 13	Revise Operating voltage & Pixel pitch, Electrical Characteristics, and Check samples by meter VIN, Isystem
E	2024/02/07	11	Revise CN1 Pin 4&8 to Input

# Contents

1. Smart Display Classification Information
2. Summary
3. Product information
4. Contour Drawing
5. Absolute Maximum Ratings
6. Electrical Characteristics
7. BOM
8. Block diagram
9. Interface
10. Reliability
11. Product inspection check list

# 1. Smart Display Classification Information

W	L	OF	000430	00W	G	D	AA	S	A	00
①	②	③	④	⑤	⑥	⑦	⑧	⑨	⑩	⑪

①	W: WINSTAR products									
②	Type: L:Standard K:Customization									
③	Display Type:	Standard:	0H: Character STN 0X: Graphic STN (TAB/COF) 0F: TFT EH: Character OLED EX: OLED (TAB/COF)	0G: Graphic STN 0P: Graphic STN (COG) EG: Graphic OLED EP: OLED (COG)						
		Customization:	DH: Character DN: Graphic ED: OLED	DG: Graphic STN OJ: TFT						
④	Display size: (diagonal) / Display format: (resolution)	Character STN:	e.g., 8x1: 000801 16x2: 001602 24x4: 002404							
		Graphic STN:	e.g., 128x64: 012864 320x240: 320240							
		TFT Size (inch):	000096-0.96" / 000350-3.5" / 000430-4.3" / 000570-5.7" 000700-7.0" / 000800-8.0" / 001020-10.2" / 001210-12.1" (The last two digits are two digits after the decimal point)							
	OLED:	e.g., 128x64: 012864 Customization: 0001XX								
⑤	Serial No:	0A1 ~ 0ZZ	Customization STN: 000							

⑥	Touch Panel Type:	N: Without TP T: RTP G: CTP								
⑦	Model Interface:	A: CAN	H: HDMI	X: Combined						
		B: Bluetooth	R: Memory Specified	Y: Proprietary interface						
		C: Controller Specified	N: Ethernet							
		D: RS485	J: Analog I/O							
		E: RS232	K: USB							
		F: USART	L: WIFI							
		G: Logic I/O	M: Zigbee							
⑧	Interface Serial No.:	AA ~ ZZ								
⑨	Control Category:	S: Smart Display N: Non-specified E: Entry								
⑩	Special Code:	A → Generic B → Industrial C → Automotive D → Medical								
⑪	Model code:	00 ~ ZZ								

## **2. Summary**

### **4.3 Inch Smart Display (RS485 series) Features**

1. DC 5-24V working voltage.
2. Self-testing after booting function.
3. RS485 communication interface with Modbus protocol.
4. Built in flash memory, store the fonts and pictures.
5. Support capacitive touch panel (CTP).
6. Embedded buzzer controlled by Master Device.
7. Demo set HOST can be used on multiple platforms, such as Computer (with USB to RS-485 Dongle), MCU.

WINSTAR DISPLAY CO., LTD

### 3. Product information

#### General information

Item	Standard Value	Unit
Operating voltage	5-24	Vdc
Communication Interface	RS485 differential	-
MCU	STM32F750	N/A
Flash Memory	16	MB
SDRAM Frequency	108	Mhz
LCD display size	4.3	inch
Dot Matrix	480 × RGB × 272(TFT)	dots
Module dimension	119.3(W) × 67.2(H) × 12.45(D)	mm
Active area	95.04(W) × 53.856(H)	mm
Pixel pitch	0.198(H) × 0.198(V)	mm
LCD type	TFT, Normally Black, Transmissive	
View Direction	80/80/80/80	
Aspect Ratio	16:9	
With /Without TP	With CTP	
Surface	Glare	

# 4. Contour Drawing

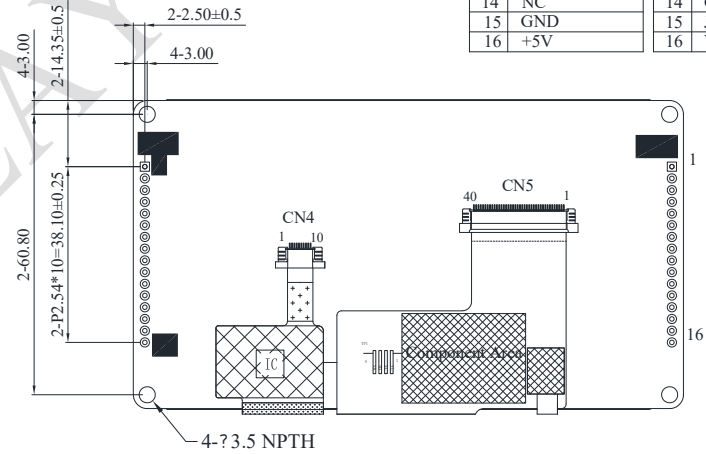
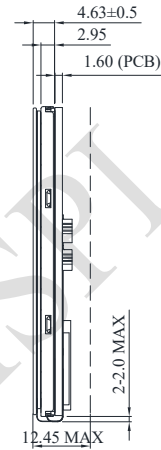
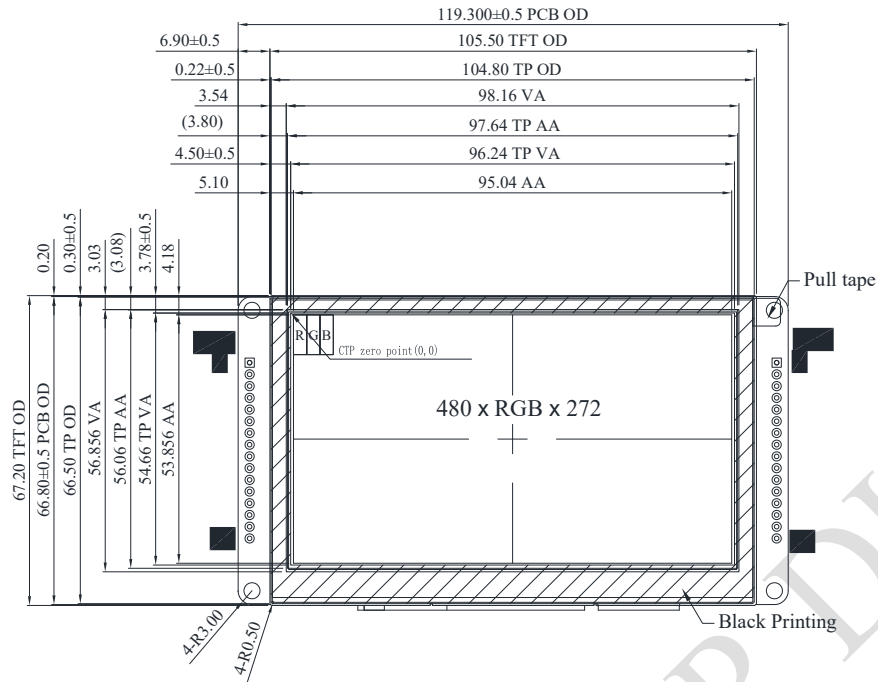

CN1		CN2	
PIN	SYMBOL	PIN	SYMBOL
1	GND	1	NC
2	RS485+	2	NC
3	RS485-	3	NC
4	VDD_5V	4	NC
5	GND	5	NC
6	NC	6	NC
7	NC	7	NC
8	VDD_5V	8	NC
9	NC	9	NC
10	NC	10	GND
11	GND	11	JTAG SWDO
12	GND	12	NRST
13	NC	13	JTAG SWDI
14	NC	14	GND
15	GND	15	JTAG SWCLK
16	+5V	16	VDD3V

The non-specified tolerance of dimension is  $\pm 0.3$  mm.



## 5. Absolute Maximum Ratings

Item	Symbol	Min	Typ	Max	Unit
Operating Temperature	TOP	-30	—	+80	°C
Storage Temperature	TST	-30	—	+80	°C

Note: Device is subject to be damaged permanently if stresses beyond those absolute maximum ratings listed above  
1. Temp.  $\leq 60^{\circ}\text{C}$ , 90% RH MAX. Temp.  $> 60^{\circ}\text{C}$ , Absolute humidity shall be less than 90% RH at  $60^{\circ}\text{C}$

## 6. Electrical Characteristics

Item	Symbol	Min	Typ	Max	Unit	Remark
Supply Voltage	VCC	5	12	24	V	
Supply Current	ICC	-	170		mA	

Note: A 10uF/50V~100uF/50V electrolytic capacitor must be added to the power supply if the device supply voltage exceeds 12V.

## 7. BOM

Item	Description	Remark
LCM	WF43WTWAEDNGA#	
PCBA	SV10004R300WA00N0104	

## 8. Block diagram

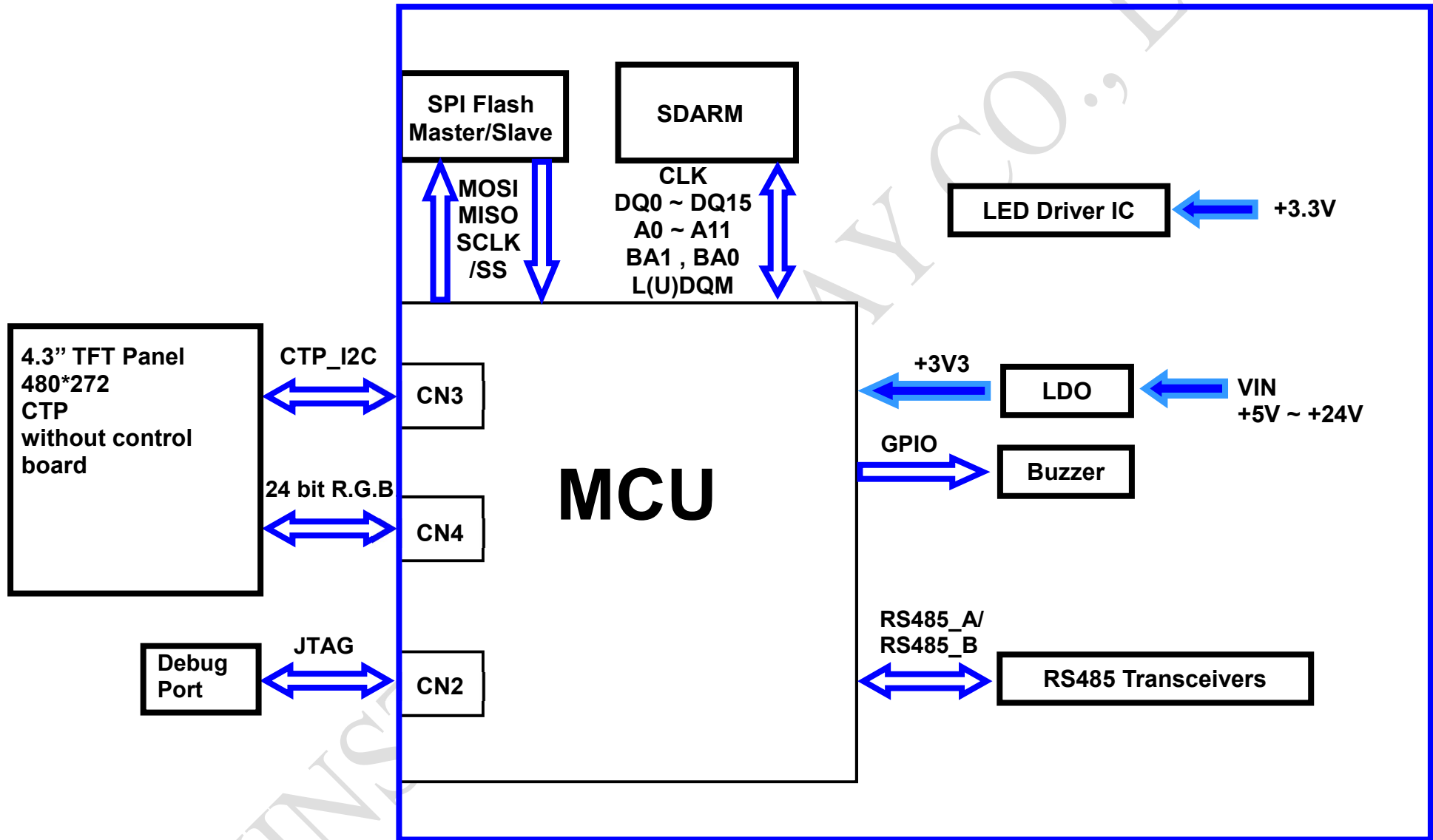

## 9. Interface

### CN1 definition:

Pin	Symbol	Function	Remark
1	GND	GND	Output
2	RS485+	RS485 D+	I/O
3	RS485-	RS485 D-	I/O
4	+5V	VIN	Input
5	GND	GND	Output
6-7	NC	--	--
8	+5V	VIN	Input
9-10	NC	--	--
11-12	GND	GND	Output
13-14	NC	--	--
15	GND	Power GND	Input
16	+5V	Power +5V ~ +24V	Input

### CN2 definition:

Pin	Symbol	Function	Remark
1-9	NC	--	--
10	GND	GND	Output
11	JTAG_SWDO	Data pin for JTAG interface	I/O
12	NRST	Reset pin for JTAG interface	Input
13	JTAG_SWDI	Data pin for JTAG interface	I/O
14	GND	GND for JTAG interface	Output
15	JTAG_SWCLK	CLK pin for JTAG interface	Input
16	VDD3V	3.3V power for JTAG interface	Output

# 10. Reliability

Content of Reliability Test (Wide temperature, -30°C~80°C)

Environmental Test			
Test Item	Content of Test	Test Condition	Note
High Temperature storage	Endurance test applying the high storage temperature for a long time.	80°C 200hrs	2
Low Temperature storage	Endurance test applying the low storage temperature for a long time.	-30°C 200hrs	1,2
High Temperature Operation	Endurance test applying the electric stress (Voltage & Current) and the thermal stress to the element for a long time.	80°C 200hrs	—
Low Temperature Operation	Endurance test applying the electric stress under low temperature for a long time.	-30°C 200hrs	1
High Temperature/ Humidity Operation	The module should be allowed to stand at 60°C,90%RH max	60°C,90%RH 96hrs	1,2
Thermal shock resistance	The sample should be allowed stand the following 10 cycles of operation <div style="text-align: center;"> <p style="margin: 0;">-30°C    25°C    80°C</p> <p style="margin: 0;">30min    5min    30min</p> <p style="margin: 0;">1 cycle</p> </div>	-30°C/80°C 10 cycles	—
Vibration test	Endurance test applying the vibration during transportation and using.	Total fixed amplitude : 1.5mm Vibration Frequency : 10~55Hz One cycle 60 seconds to 3 directions of X,Y,Z for Each 15 minutes	3
Static electricity test	Endurance test applying the electric stress to the terminal.	VS=±2KV~±6KV(contact),±2KV~±8KV (air), RS=330Ω CS=150pF 10 times	—

Note1: No dew condensation to be observed.

Note2: The function test shall be conducted after 4 hours storage at the normal Temperature and humidity after remove from the test chamber.

Note3: The packing have to including into the vibration testing.

# 11. Product inspection check list

Check samples by meter  $V_{IN}$ ,  $I_{system}$

Item	No 1	No 2	No 3	Note
$V_{IN}$ (V)	12	12	12	
$I_{system}$ (mA)	169	171	170	

Check sample Reliability Test

Item	Result	Note
Thermal shock	—	-30°C/80°C 10 cycles
High Temperature Operation	—	80°C 200hrs
Low Temperature Operation	—	-30°C 200hrs
Static electricity test	—	$V_S = \pm 2KV \sim \pm 6KV$ (contact), $\pm 2KV \sim \pm 8KV$ (air), $R_S = 330\Omega$ $C_S = 150pF$ 10 times
Vibration test	—	Total fixed amplitude : 1.5mm Vibration Frequency : 10~55Hz One cycle 60 seconds to 3 directions of X,Y,Z for Each 15 minutes

- Prepare sets for testing