

# PRODUCT SPECIFICATION

PRODUCT NAME :	Cooling Fan
CATEGORY :	Axial Fan
MODEL :	9GV1424P1H004
CUSTOMER P/N :	—
SPECIFICATION No. :	S5326511

Signature

We would kindly like you to check all specifications, make your signature on one copy, and return it to us by 29 February, 2024 .  
When you have corrections, please write them in red. If this specification is not returned by the above date, we will consider it approved and deliver the products following it.



## Caution

- To ensure that this fan is used safely, be sure that you read and understand the following precautions fully and use it only as directed.
- Be sure to read these Safety Precautions carefully before installing, connecting, operating, maintaining, or inspecting the fan. Follow all the precautions and directions given here.
- The fan has been designed and manufactured for built-in use in general industrial machinery, and might not be used otherwise.
- The fan falls into the Category 16 (Class 84, Item 14) of the Appended Table 1 of the Export Trade Control Order. When exporting the fan either as a standalone item or as part of another product, be sure to implement the necessary procedures including the “Informed Cases” and “Objective Cases” based on the “Catch-All Controls” defined by the Ministry of Economy, Trade and Industry of Japan.
- When disposing the fan, treat it as industrial waste. For instructions on proper disposal methods, please contact local government authorities.
- When using the fan in equipment that could affect people’s lives or health, that is used on a car, ship, or aircraft, or that could have a major impact on society or on the public, use it at your own discretion only after deploying sufficient safety measures and making prior evaluation.
- Fully understand the Safety Precautions described in this document before using the product. SANYO DENKI will not be liable for any accidents resulting in death, injury, or property damage due to the failure of the fan.
- Safety precautions necessary for preventing any possible bodily injury or damage to property or equipment are ranked in two levels:

<b>Warning</b>	Denotes hazards which could cause severe bodily injury or death as a result of incorrect operation.
<b>Caution</b>	Denotes hazards which could cause bodily injury or property damage as a result of incorrect operation.

**Note:** Even those items marked ‘**Caution**’ might also result in serious consequences depending on the situation. Be sure to observe them carefully to the same extent as items marked ‘**Warning**.’

## SANYO DENKI CO., LTD.

APPROVED BY	CHECKED BY	DESIGNED BY
2024-02-15	2024-02-15	2024-02-15



# Safety Precautions (1/3)

## WARNING

- When using the fan in the following equipment, use it at your own discretion only after deploying sufficient safety measures and making prior evaluation.
  - Equipment that could affect people's lives or health
  - Equipment that is used on a car, ship, or aircraft
  - Equipment that could have a major impact on society or on the public
  - SANYO DENKI will not be liable for any accidents involving human casualties (death, injury, etc.) or property damage due to the failure of the fan while use in such equipment.
- Ensure that wiring is done correctly. Failure to do so might result in fire, burns, or electrical shock.
- If there are any grounding taps or wires, ground them securely. Failure to do so might result in electric shock.
- Never use in explosive atmospheres, as doing so might result in fires, burns, or bodily injury.
- Do not operate the fan with live parts exposed. Doing so might result in electric shock.
- Never allow any persons or objects to approach or come into contact with the fan's rotor while in operation, as doing so might result in damage or personal injury.
- Turn off the power and stop using the fan immediately if you notice any sparks, smoke, odd odors or sounds, or anything unusual during operation. Failure to do so might result in fire, bodily injury, or electrical shock.
- Never allow the fan to fall, topple over, or be subjected to excessive shocks when moving it. Doing so might result in product failure or performance deterioration.
- The fan should be handled by technically qualified personnel or someone with sufficient expertise; the personnel shall be assigned at your own discretion.
- Never attempt to disassemble, repair, or alter the fan in any way, as doing so might result in electrical shock, fire, or bodily injury.

## Caution

### Handling

- Installation, mounting, connections, wiring, and relocation of the fan should be done by technically qualified personnel or someone with sufficient expertise; the personnel shall be assigned at your own discretion.

Never perform such work while the product is on, as this might lead to injury, electrical shock, burns, or fire.
- Do not operate the fan if it is not secured, nor while held in hand.
- Never allow yourself to come into contact with the fan when measuring insulation resistance or dielectric strength. There is danger of electric shock.
- Never attempt to disassemble or alter the fan in any way. Doing so might not only result in substandard performance, but also fire, burns, bodily injury, or electrical shock.

### Operation

- Take protective measures for the equipment in which the fan is embedded in case the fan stops, malfunctions, or fails during operation.
- Never use the fan at voltages, temperatures, or any other parameters exceeding those given in the product specifications. Otherwise, it might result in substandard performance, failure, fire, bodily injury, or electrical shock.
- Any specifications not listed in this document, such as fan and sensor operation after the fan power is turned off, will not be covered by our warranty. Please contact us in advance if you need to make any special arrangements for the specifications not listed in this document.
- Using a power supply with insufficient capacity might result in faulty fan operation because an inrush current several times larger than the rated current will flow at the moment of fan startup. Be sure to use a power supply with sufficient capacity.
- Start all fans at the same time when two or more fans are positioned in equipment in a way that creates wind interference. If the fan is exposed to wind from other fans at startup, it might result in fan failure or faulty fan startup. Also, evaluate the influence to individual fans in advance and use them at your own discretion.
- Never connect or disconnect lead wires, plug cords, or connectors while the power is on. Be sure to connect or disconnect them while holding the frame only after power-off. Otherwise, it might result in fan damage or electrical shock.
- Do not remove the lead wire of the fan from the frame hook. Doing so might scratch and damage the surface of the lead wire.

# Safety Precautions (2/3)

## Caution

### Operation (Continued)

- Do not remove the nameplate. Doing so might result in fan failure or electrical shock.
- Do not press down hard on the nameplate of the fan. Otherwise, the nameplate might break or come into contact with the shaft, hindering proper operation.
- The fan might be damaged or burned out if foreign objects or external forces hinder normal fan operation.
- Do not use the power supply's PWM to control the speed of the fan. Doing so might result in fan malfunction.
- Do not turn the power on or off on the negative power line. Doing so might damage the fan.
- Turning the power on and off frequently or turning the power back on before the fan comes to a complete stop might result in fan failure or damage. Before conducting such operations, fully evaluate the equipment in which the fan is embedded.
- The IP ratings of Splash Proof Fans apply only to the live electric parts and motor coils of the fan in accordance with IEC 60529. The protection does not apply to the non-live parts of the fan. If the fan is to be used for a long period of time in an environment subject to dust, water, or condensation, take measures required for the operating environment.
- Do not wash the fan during maintenance of equipment. Doing so might result in failure of the fan.
- For DC fans, even if the positive and negative lead wires of the power supply are connected in reverse, the fan will not be affected by the motor protection function.  
However, when wiring fans with sensors or PWM speed control function, connecting positive and negative leads in reverse may damage the fans.

### Installation (Common to All Fans)

- Install and secure the fan properly with its weight and vibration during operation taken into account. Failure to do so might result in bodily injury or equipment failure due to the fan or its parts falling off.
- Ensure that the fan is installed in the right orientation. Failure to do so might result in bodily injury or equipment failure.
- For the fan to perform to its full capacity, secure air vents and take measures to prevent foreign objects from entering the fan. Failure to do so might result in bodily injury or fan failure.
- Do not subject the fan to excessive shock. Doing so might result in failure or substandard performance of the fan.
- Pulling or pinching lead wires might result in damage and stress to the wire. Also, make connections so that the lead wires do not come into contact with the rotating blades. Failure to do so might result in equipment failure or electrical shock.
- Take proper precautions against static electricity when wiring. Failure to do so might cause failure of the fan or equipment.
- Take safety measures such as installing a finger guard and displaying a warning symbol if there is any danger of fingers or objects coming into contact with the rotating blades. Failure to do so might result in bodily injury or fan failure.
- When installing an inlet nozzle, finger guard, filter, or base plate to the fan, ensure that they are positioned correctly according to this Product Specification and other documents so that they do not come into contact with the rotating blades. Also, use the fan only after checking that the rotating blades do not come into contact with anything. Otherwise, it might result in equipment failure.
- Please use only genuine SANYO DENKI inlet nozzles and finger guards.
- Make connections correctly in accordance with the information of this Product Specification and the nameplate of the fan. Failure to do so might result in equipment failure or the malfunction, failure, or performance degradation of the fan.

### Installation (Axial Fan and Blower)

- When mounting the fan with screws, make sure that the screw and base plate will not deform the frame of the fan before mounting. A deformed frame might result in failure or substandard performance of the fan.
- When mounting the fan with screws, ensure that the screw tightening torque is correct. If the tightening torque exceeds the recommended torque, the fan frame might be deformed or damaged. Choose a ribbed frame model if mounting fans with plastic frames through both sides of the frame with through-screws. To prevent loose screws, use plain washers or spring washers. For the screwing torque of each fan type, contact SANYO DENKI or a SANYO DENKI distributor.
- Note that mounting the fan with self-tapping screws might damage the fan frame.  
If using self-tapping screws, be sure to choose the screw that we recommend and conduct evaluations before using it.

# Safety Precautions (3/3)

## Caution

### Installation (Centrifugal Fan)

- The fan shall be mounted with screws. For the screw size for each fan model, see this Product Specification.
- Choose screws with the right length with information such as the fan mounting depth and base plate thickness taken into account. Failure to do so might result in stripped screw holes and improper fan mounting. For the mounting depth of each fan model, see this Product Specification.
- Ensure that the screw tightening torque is correct. If the tightening torque exceeds the recommended torque, the screw hole might be deformed or damaged. Also, to prevent loose screws, use plain washers or spring washers. For the tightening torque for each fan model, see this Product Specification.
- For the inlet nozzle and base plate installation dimensions for each fan model, see this Product Specification.

### Operating Environments

- Avoid using or storing the fan in the following environments. Otherwise, it might result in fire or the failure or performance degradation of the fan.

In environments where flammable or corrosive gas is present, where water or oil splashes, where there is much dust or humidity, where condensation occurs, where exposed to radioactive rays or direct sunlight, where a salty sea breeze blows or seawater splashes, where the fan might be contaminated by such corrosive materials as sulfurous water, sulfurous volcanic ash, organic solvents, acidic and alkali chemicals, or nuclear fuel materials, where subjected to constant vibration, strong shocks, centrifugal force, acceleration, or strong magnetic force, where electromagnetic noise radiation is present, where the electromagnetic noise overlaps into power voltage, or where subjected to rapid environmental fluctuations (temperature, humidity, pressure, etc.).

### Storage

- The fan should be stored in packaging.
- Ensure that the fan is stored in the following environments where:
  - the temperature is normal and stable;
  - the relative humidity is 20% to 85% with no sudden changes in humidity and no condensation;
  - not subjected to direct sunlight;
  - not subjected to water, oil, corrosive materials, or other hazardous substances;
  - and not subjected to vibration or shock.

### Maintenance

- Maintenance and inspections of the fan should be done by technically qualified personnel or someone with sufficient expertise; the personnel shall be assigned at your own discretion. Otherwise, it might result in fire, burns, bodily injury, or electrical shock.
- Never perform any maintenance or inspections while the fan is in operation. Also note that the blades continue to rotate for some time immediately after operation ceases. Always confirm that all rotating parts have come to a stop before beginning work. Failure to do so might result in bodily injury.
- Never use gasoline, paint thinner, benzene, or any other organic solvents to clean the fan. Also, avoid placing excessive stresses on the fan. Otherwise, it might result in product deformation or performance degradation.

### Contact:

**SANYO DENKI CO., LTD.**

3-33-1 Minami-Otsuka, Toshima-ku, Tokyo 170-8451

Tel: +81 3 5927 1020

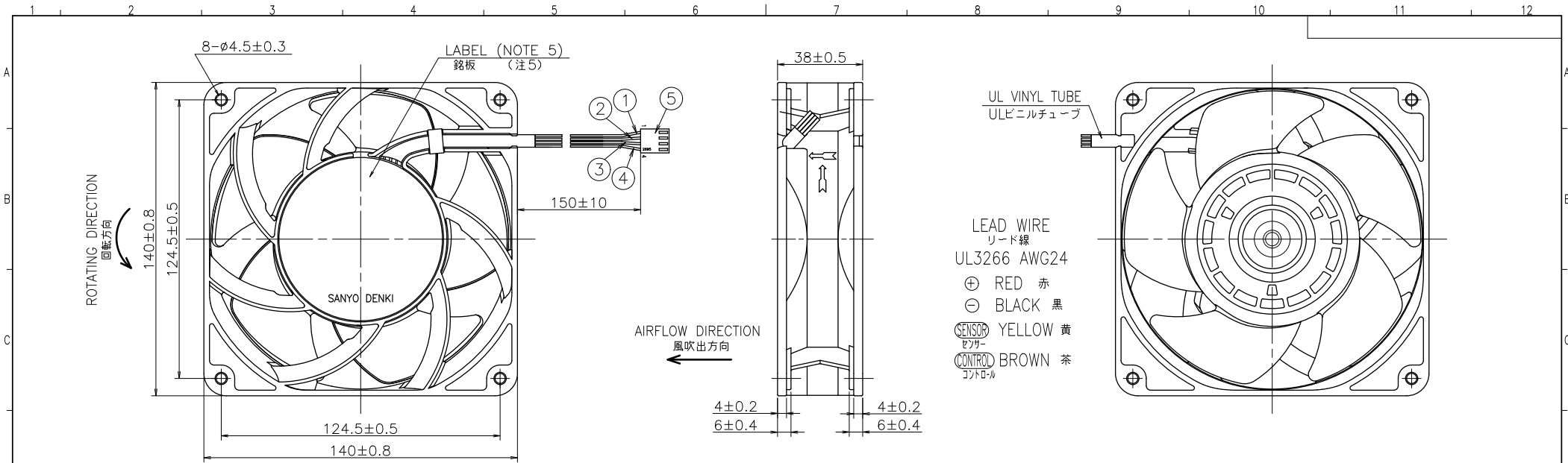

PWM DUTY CYCLE PWMデューティサイクル	100 %	20 %	0 %
RATED VOLTAGE 定格電圧	24 V DC		
OPERATING VOLTAGE 使用電圧範囲	21.6 V DC ~ 26.4 V DC		
RATED CURRENT 定格電流	0.85 A AT 24 V DC (DC24 Vにて)	0.13 A AT 24 V DC (DC24 Vにて)	0.04 A MAX. AT 24 V DC 以下 (DC24 Vにて)
RATED SPEED 定格回転速度	5200 ± 520 min <sup>-1</sup> AT 24 V DC (DC24 Vにて)	2300 ± 690 min <sup>-1</sup> AT 24 V DC (DC24 Vにて)	NO ROTATION 回転停止
INSULATION RESISTANCE 絶縁抵抗	10 MΩ MIN. AT 500 V DC (NOTE2) DC500 Vにて10 MΩ以上(注2)		
DIELECTRIC STRENGTH 絶縁耐圧	1 MINUTE AT 500 V AC, 50/60 Hz (NOTE2) AC50/60 Hz, 500 Vにて1分間耐えること(注2)		
OPERATING TEMPERATURE 使用温度範囲	- 20 °C ~ + 70 °C		
SOUND PRESSURE LEVEL 騒音レベル	62 dB(A) (NOMINAL) (NOTE1) (中心値) (注1)	39 dB(A) (NOMINAL) (NOTE1) (中心値) (注1)	
MASS 質量	APPROX. 630 g 約		
MATERIAL 材質	FRAME:ALUMINUM WITHOUT PAINTING, IMPELLER : PLASTICS フレーム:アルミダイカスト 無塗装, 羽根 : 樹脂成形品		
BEARING SYSTEM 軸受	2 BALL BEARINGS ボールベアリング		
CONTROL TERMINAL コントロール端子	SOURCE CURRENT : 1 mA MAX. AT CONTROL VOLTAGE 0 V. ソース電流 : 以下(コントロール電圧 0 V時)		
	SINK CURRENT : 1 mA MAX. AT CONTROL VOLTAGE 5.25 V. シンク電流 : 以下(コントロール電圧 5.25 V時)		
	CONTROL TERMINAL VOLTAGE : 5.25 V MAX.(OPEN CIRCUIT) 端子電圧 : 以下(コントロール端子オープン時)		

5	CONTACT コンタクト	MOLEX : 08-55-0101 モレックス
	CONNECTOR コネクタ	MOLEX : 22-01-3047 (2695-04RP) モレックス
4	LEAD WIRE リード線	UL3266 AWG24 BROWN PIN No.4 茶
3	LEAD WIRE リード線	UL3266 AWG24 YELLOW PIN No.3 黄
2	LEAD WIRE リード線	UL3266 AWG24 RED PIN No.2 赤
1	LEAD WIRE リード線	UL3266 AWG24 BLACK PIN No.1 黒
No.	PARTS 番号	REMARKS 備考

- FOR SENSOR SPEC., SEE 9D0001H246.  
センサー仕様は、9D0001H246による。  
THE SWITCHING BY PWM CONTROL MAY INFLUENCE THE SENSOR OUTPUT.  
PWM制御によるスイッチングがセンサー出力に影響する場合があります。
- PRINT PRODUCT NAME, MODEL No., MANUFACTURER, AND MANUFACTURED DATE ETC.  
品名, 型名, 製造会社名 及び 製造年月日等を表示する。
- ALL VALUES OF EACH CHARACTERISTICS ARE AT ROOM TEMPERATURE AND NORMAL HUMIDITY.  
諸特性は常温、常温での値です。

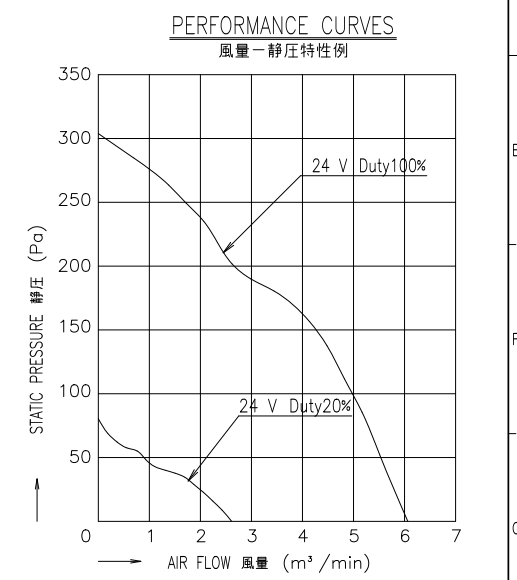

NOTE: 1. MEASURED AT 1 m DISTANCE FROM THE AIR INLET.  
注 ファン吸込側より1 mにて測定する。  
2. MEASURED BETWEEN LEAD WIRE CONDUCTORS AND FRAME.  
リード線導体部とフレームとの間。  
3. MOTOR IS PROTECTED FROM DAMAGE OF LOCKED ROTOR CONDITION AT THE OPERATING VOLTAGE.  
ファン拘束時焼損の恐れはない。

ECN No.	名称 Title	San Ace 140 (9GV) RIBLESS/PULSE_SENSOR/PWM_CONTROL	
単位 Unit mm	新規 New Design J.OISHI 24-02-08	審査 Checked By A.NAKAYAMA 24-02-13	設計 Designed By J.OISHI 24-02-08
尺度 Scale -	図面番号 Dwg. No.	89GV1424P1H004 A	
SANYO DENKI		承認 Approved By N.MURAKAMI 24-02-13	ユーザー User D12
A2G-F5		設計 Designed By J.OISHI 24-02-08	ページ Page E0

PWM DUTY CYCLE (BETWEEN CONTROL LEAD AND ⊖ LEAD) - SPEED CHARACTERISTIC (REFERENCE)  
 PWMデューティサイクル (コントロール線-⊖間) - 回転速度特性例

VOLTAGE : 24 V DC  
 電圧  
 PWM FREQUENCY : 25 kHz  
 PWM周波数  
 (AT ROOM TEMPERATURE, NORMAL HUMIDITY)  
 (常温、常湿にて)

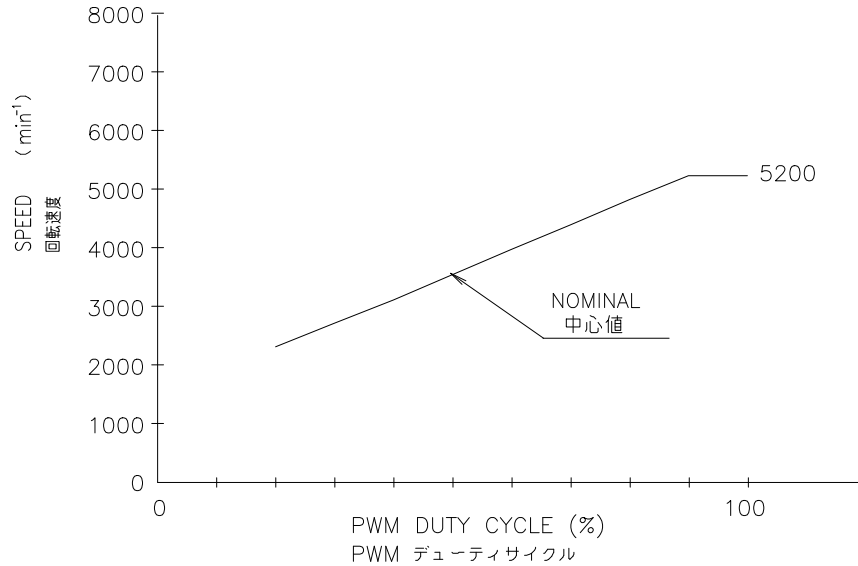

PWM INPUT SIGNAL

PWM入力信号

$$\frac{T_1}{T} \times 100 = \text{PWM DUTY CYCLE}(\%)$$

PWMデューティサイクル

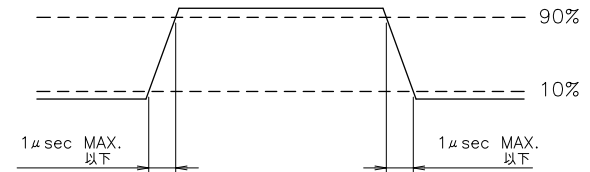
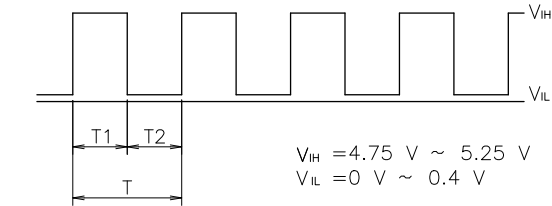

CONNECTION (REFERENCE)

結線例

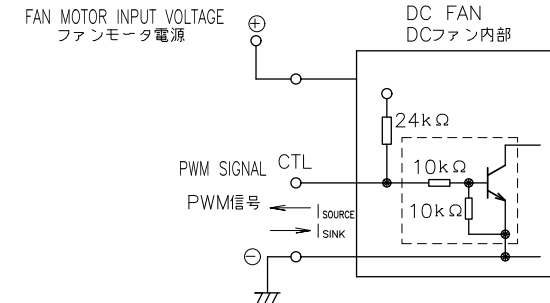

- NOTE 1. WHEN PWM DUTY CYCLE IS 0%, THE SPEED IS 0 min<sup>-1</sup>.  
 注 PWMデューティサイクルが 0%の時、回転速度は0 min<sup>-1</sup>であること。
2. WHEN PWM DUTY CYCLE ARE 20% AND 100%, REFER TO PAGE 1 FOR THE SPEED.  
 PWMデューティサイクルが 20%と100%の時、回転速度は1頁を参照のこと。
3. WHEN THE CONTROL LEAD WIRE IS NOT CONNECTED,  
 THE SPEED IS THE SAME SPEED AS AT 100% OF PWM DUTY CYCLE.  
 PWM入力端子がオープン状態の時、回転速度はPWMデューティサイクル100%時と同じであること。
4. PWM FREQUENCY IS 25 kHz.  
 PWM周波数は、25 kHzであること。
5. THE PWM SIGNAL THAT SATISFIES THIS SPECIFICATION SHALL BE INPUT.  
 IT CAN BE USED WITH OPEN COLLECTOR OR DRAIN INPUT.  
 NOTE THAT WHEN USING AN OPEN COLLECTOR OR DRAIN INPUT,  
 OR INPUTTING A DIFFERENT VOLTAGE OR FREQUENCY,  
 THE SPEED RELATIVE TO THE PWM DUTY CYCLE MAY DIFFER FROM THIS SPECIFICATION.

本仕様を満足するPWM信号を入力のこと。  
 オープンコレクタ、ドレイン入力でも使用できる。  
 オープンコレクタ、ドレイン入力で使用した場合、または異なる電圧、周波数を入力した場合には、  
 PWMデューティサイクルに対する回転速度が本仕様と異なる場合があるので注意のこと。

ECN No.		名称 Title	
mm		San Ace 140 (9GV)	
J.OISHI		RIBLESS/PULSE_SENSOR/PWM_CONTROL	
24-02-08		9GV1424P1H004	
A		Rev.	
SANYO DENKI		SANYO DENKI	
CO.,LTD.		CO.,LTD.	
N.MURAKAMI		A.NAKAYAMA	
24-02-13		24-02-13	
Group D12		User E0	
Page 2/2		Page 2/2	

# SENSOR SPECIFICATION FOR BRUSHLESS DC FAN

## ブラシレスDCファン センサー仕様

1. OUTPUT CIRCUIT - OPEN COLLECTOR  
出力回路-オープンコレクタ

2. SPECIFICATION  
仕様

$$V_{CE} = +30 \text{ V DC MAX.}$$

$$I_c = 10 \text{ mA MAX. (} V_{CE}(\text{SAT}) = 0.6 \text{ V MAX.)}$$

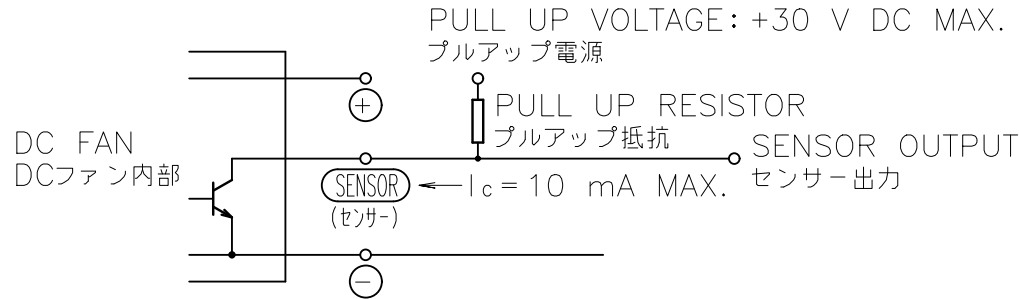

3. WAVEFORM OF SENSOR OUTPUT  
センサー出力波形

(a) RUNNING CONDITION  
通常回転時

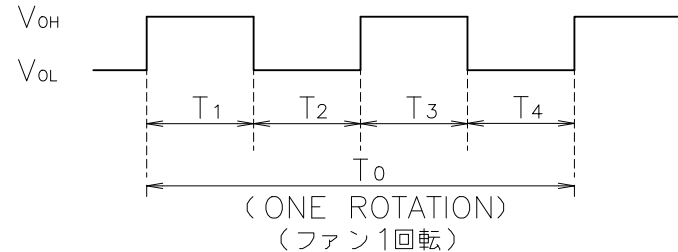

$$T_{1\sim 4} \doteq (1/4) T_0$$

$$T_{1\sim 4} \doteq (1/4) T_0 = 60/4 \text{ N (s)}$$

$N = \text{FAN ROTATION SPEED (min}^{-1}\text{)}$   
ファン回転速度

(b) LOCKED ROTOR CONDITION  
羽根ロック時

SENSOR OUTPUT IS FIXED EITHER  
(b-1) OR (b-2) AT LOCKED ROTOR CONDITION.

下図のどちらかに固定される。

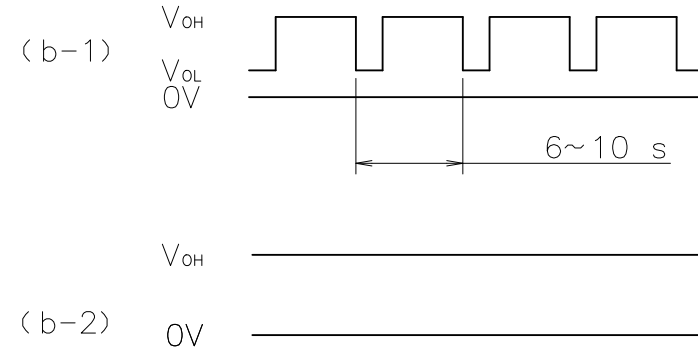

				承認 APPROVED BY T.IKEDA 14-07-25	PULSE SENSOR パルスセンサー
			単位 UNIT mm	審査 CHECKED BY T.TODA 14-07-25	名称 TITLE SENSOR SPECIFICATION
A	新規作成 谷口	14-07-25	尺度 SCALE	設計 DESIGNED BY N.TANIGUCHI 14-07-25	BLDCファン センサー仕様
記号 REV.	記事 DESCRIPTION	日付 DATE		図番 DWG NO.	REV.
	山洋電気株式会社 SANYO DENKI CO.,LTD.				9D0001H246 A
			A3G-F1		00902770