

THIS DRAWING CONTAINS INFORMATION PROPRIETARY TO RF INDUSTRIES.
 ANY UNAUTHORIZED USE OF THIS DRAWING IS EXPRESSLY PROHIBITED
 WITHOUT WRITTEN PERMISSION FROM RF INDUSTRIES.
 ANY VIOLATION IS PUNISHABLE UNDER U.S. COPYRIGHT LAWS.

ALL DIMENSIONS ARE REFERENCE ONLY

PART NO.		RF35M-35F-00000		
REV	DESCRIPTION	DWN	DATE	APPROVED
-	ENGINEERING RELEASE	JDMc	5/26/00	JDMc
A	MODIFIED MATERIAL NOTE	JDMc	12/9/05	JDMc

SPECIFICATIONS:

IMPEDANCE RANGE: 50 Ohms
FREQUENCY RANGE: DC to 34 GHz
VSWR: 1.04 + .006 f (f=GHz) Max. DC-34 GHz
CONTACT RESISTANCE:
 Outer Contact= 2.0 milliohms
 Center Contact= 3.0 milliohms
CONNECTOR DURABILITY: 500 Cycles minimum
TEMPERATURE RANGE: -55° C TO 105° C

MATERIALS:

Body and Body Components:
 Non-Magnetic stainless steel, per ASTM
 A582, class 303 condition A.
 Contacts: Beryllium copper,
 per QQ-C-530, heat treated per
 MIL-H-7199
 Insulators: REXOLITE

FINISH:

Center Contacts:
 .000050 min. gold per MIL-G-45204B
 Type II, Grade C, Class 1
 over .000050 min. Nickel per
 QQ-N-290A
 Other Metal Parts:
 Passivated, (as specified)
 to meet the finish and
 corrosion requirements of MIL-C-39012.

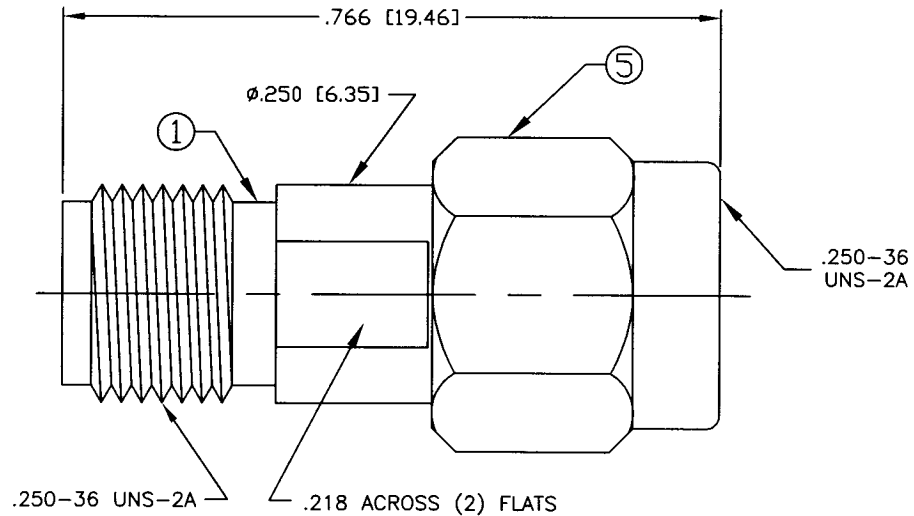

1	BODY	1	SST. 303	PASSIVATE
2	BODY	1	SST. 303	PASSIVATE
3	CONTACT	1	Be.Cu.	GOLD, 50μ"
4	CONTACT	1	Be.Cu.	GOLD, 50μ"
5	COUPLING NUT	1	SST. 303	PASSIVATE
6	RETAINING RING	1	Be.Cu.	----
7	GASKET	1	SILICONE	----
8	DIELECTRIC	1	REXOLITE	----
9				
10				
11				
12				
13				
14				
#	DESCRIPTION	QTY	MATERIAL	FINISH

000000	
DRAWN	JDMc
CHECKED	JDMc
ORJ DRAWN	JDMc
DATE	12/9/05
DATE	9/24/02

UNLESS OTHERWISE SPECIFIED:
 1. REMOVE ALL BURRS
 2. BREAK ALL CORNERS & EDGES .005 R. MAX.
 3. CHAMFER 1ST & LAST THREADS 45°
 4. SURFACE ROUGHNESS 63 FINISH MIL-STD-10
 5. DIAMETERS ON COMMON CENTERS TO BE CONCENTRIC WITHIN .002 T.I.R.
 6. ALL DIMENSIONS ARE AFTER PLATING.

DIMENSIONS ARE IN INCHES AND [MILLIMETERS]
 UNLESS OTHERWISE NOTED TOLERANCES ARE:
 DECIMALS DIAMETER
 .xxx±.003 [.08] .xxx±.001 [.03]
 .xx±.005 [.13] .xx±.003 [.08]

RF

connectors

7610 MIRAMAR RD
SAN DIEGO, CA 92126
(858) 549-6340
(858) 549-6345 FAX

DIVISION OF RF INDUSTRIES, LTD.

3.5mm PLUG TO JACK

ADAPTER

SIZE A	CABLE GROUP N/A	DWG NO. RF35M-35F-00000	REV A
-----------	--------------------	----------------------------	----------

SCALE: NTS CAD FILE OUTLINE SHEET 1 OF 1