

# PCAN-miniPCIe FD

## User Manual

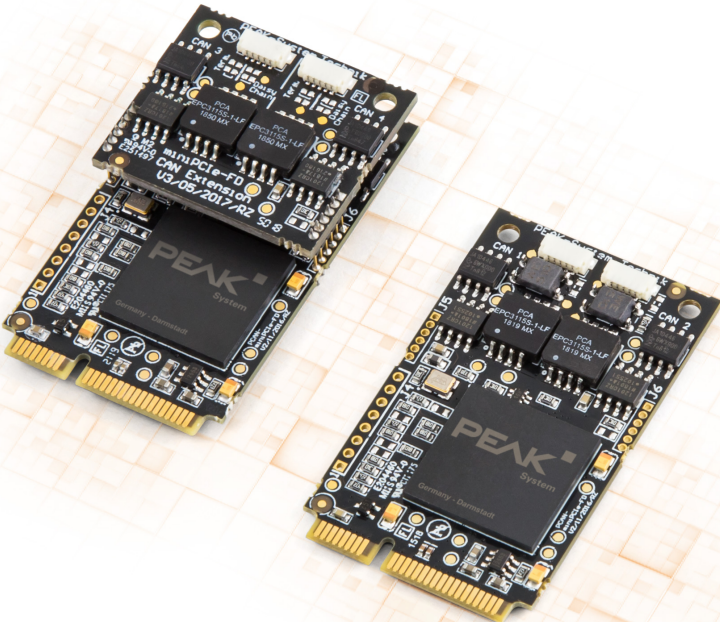

# Relevant Products

Product name	Model	Part number
PCAN-miniPCIe FD Single Channel	One CAN channel, galvanic isolation for CAN connection	IPEH-004045
PCAN-miniPCIe FD Dual Channel	Two CAN channels, galvanic isolation for CAN connection	IPEH-004046
PCAN-miniPCIe FD Quad Channel	Four CAN channels, galvanic isolation for CAN connection	IPEH-004047

The cover picture shows the products PCAN-miniPCIe FD Dual Channel and Quad Channel. The Single Channel model has an identical form factor like the Dual Channel model but varies in equipment.

## Imprint

PCAN is a registered trademark of PEAK-System Technik GmbH. CiA® is a registered community trade mark of CAN in Automation e.V.

All other product names in this document may be the trademarks or registered trademarks of their respective companies. They are not explicitly marked by ™ or ®.

© 2024 PEAK-System Technik GmbH

Duplication (copying, printing, or other forms) and the electronic distribution of this document is only allowed with explicit permission of PEAK-System Technik GmbH. PEAK-System Technik GmbH reserves the right to change technical data without prior announcement. The general business conditions and the regulations of the license agreement apply. All rights are reserved.

PEAK-System Technik GmbH  
Leydheckerstraße 10  
64293 Darmstadt  
Germany

Phone: +49 6151 8173-20

Fax: +49 6151 8173-29

[www.peak-system.com](http://www.peak-system.com)

[info@peak-system.com](mailto:info@peak-system.com)

Document version 2.2.0 (2024-06-10)

# Contents

<b>Imprint</b> .....	<b>2</b>
<b>Relevant Products</b> .....	<b>2</b>
<b>Contents</b> .....	<b>3</b>
<b>1 Introduction</b> .....	<b>4</b>
1.1 Properties at a Glance .....	5
1.2 System Requirements .....	5
1.3 Scope of Supply .....	6
<b>2 Installation</b> .....	<b>7</b>
2.1 Install Device Driver Setup .....	7
2.2 Connect the CAN interface .....	7
2.3 Check Operational Readiness .....	8
<b>3 Connecting the CAN Bus</b> .....	<b>9</b>
3.1 Connection over D-Sub Connector .....	9
3.2 Daisy Chain .....	9
3.3 Internal Termination .....	11
3.4 Cabling .....	11
<b>4 CAN Monitor PCAN-View</b> .....	<b>13</b>
4.1 Initialize CAN interface .....	14
4.2 Transmit CAN message .....	16
4.3 Additional Tabs .....	17
<b>5 API PCAN-Basic</b> .....	<b>22</b>
5.1 Features of PCAN-Basic .....	23
5.2 Principle Description of the API .....	24
<b>6 Technical Data</b> .....	<b>25</b>
<b>Appendix A CE Certificate</b> .....	<b>27</b>
<b>Appendix B UKCA Certificate</b> .....	<b>28</b>
<b>Appendix C Dimension Drawings</b> .....	<b>29</b>
<b>Appendix D Quick Reference</b> .....	<b>31</b>
<b>Appendix E Linux</b> .....	<b>32</b>
<b>Appendix F Disposal</b> .....	<b>33</b>

# 1 Introduction

The PCAN-miniPCIe FD is a CAN interface for the PCI Express Mini slot. With its space-saving format, the plug-in card is a suitable solution for connecting embedded systems to up to four CAN FD and CAN networks. There is galvanic isolation of up to 300 Volts between the computer and CAN sides. The card is available as a single, dual, or four-channel version.

The CAN FD standard (CAN with Flexible Data rate) is primarily characterized by higher bandwidth for data transfer. The maximum of 64 data bytes per CAN FD frame (instead of 8 so far) can be transmitted with bit rates up to 12 Mbit/s. CAN FD is downward-compatible to the CAN 2.0 A/B standard, thus CAN FD nodes can be used in existing CAN networks. However, in this case the CAN FD extensions are not applicable.

The monitor software PCAN-View and the programming interface PCAN-Basic for the development of applications with CAN connection are included in the scope of supply and support the standard CAN FD.



This manual describes the use of the CAN interface with **Windows**.  
Device drivers and application information for **Linux**:  
[www.peak-system.com/quick/DL-Driver-E](http://www.peak-system.com/quick/DL-Driver-E)



At the end of this manual you can find a Quick Reference with brief information about the installation and operation of the CAN interface.

# 1.1 Properties at a Glance

- CAN interface for the PCI Express Mini slot (uses PCIe lane)
- 1, 2, or 4 High-speed CAN channels (ISO 11898-2)
- Form factor PCI Express Mini (only for single and dual channel versions due to the height of the four-channel version)
- Complies with CAN specifications 2.0 A/B and FD
- CAN FD support for ISO and Non-ISO standards switchable
- CAN FD bit rates for the data field (64 bytes max.) from 25 kbit/s up to 12 Mbit/s
- CAN bit rates from 25 kbit/s up to 1 Mbit/s
- CAN bus connection via connection cable and D-Sub, 9-pin (in accordance with CiA® 106)
- FPGA implementation of the CAN FD controller
- NXP TJA1044GT CAN transceiver
- Galvanic isolation on the CAN connection up to 300 V, separate for each CAN channel
- CAN termination can be activated through solder jumpers, separately for each CAN channel
- PCIe data transfer via bus master DMA
- DMA memory access operations with 32- and 64-bit addresses
- Measurement of bus load including error frames and overload frames on the physical bus
- Induced error generation for incoming and outgoing CAN messages
- Extended operating temperature range from -40 to +85 °C (-40 to +185 °F)

# 1.2 System Requirements

Computer with:

- Operating system Windows 11 (x64), 10 (x64), or Linux
- PCI Express Mini slot with PCIe lane

## 1.3 Scope of Supply

- Plug-in card PCAN-miniPCIe FD
- Connection cable, 20 cm, including D-Sub plug for each channel (40 cm or other cable lengths on request)

### Downloads

- Device drivers for Windows 11 (x64), 10 (x64), and Linux
- CAN monitor PCAN-View for Windows
- Programming interface PCAN-Basic for developing applications with CAN connection
- Programming interfaces for standardized protocols from the automotive sector
- Manual in PDF format

## 2 Installation

This chapter covers the software setup for the CAN interface PCAN-miniPCIe FD in Windows and the installation of the CAN interface in the computer.

**Note:** For installation on Linux, see Appendix E *Linux*.

Install the driver before you install the CAN interface.

### 2.1 Install Device Driver Setup

1. Download the device driver setup from our website:  
[www.peak-system.com/quick/DL-Driver-E](http://www.peak-system.com/quick/DL-Driver-E)
2. Unpack the file `PEAK-System_Driver-Setup.zip`
3. Double-click the file `PeakOemDrv.exe`  
The driver setup starts.
4. Follow the program instructions.

### 2.2 Connect the CAN interface



**Attention!** Electrostatic discharge (ESD) can damage or destroy components on the card. Take precautions to avoid ESD.

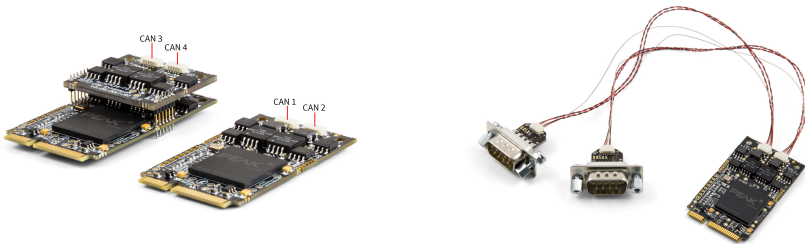

CAN ports: on the left Quad Channel, on the right Dual Channel with connection cables.

1. Shut down the computer.
2. Disconnect the computer's power supply.
3. Open the computer case.
4. Insert the CAN interface into an empty PCI Express Mini slot.
5. For each CAN channel, mount a D-Sub connector of the connection cable in a suitable recess of the computer housing.
6. For each CAN channel interconnect the SUR socket connector of the connection cable and the SUR header on the CAN interface.
7. Close the computer case.
8. Reconnect the computer power supply.
9. Turn on the computer and start Windows.  
Windows detects the new hardware and completes the driver installation.

## 2.3 Check Operational Readiness

1. Open the Windows Start menu.
2. Type `Peak Settings` and press `Enter`.  
The window *PEAK Settings* appears.
3. Select *CAN Hardware*.  
The connected CAN interface is displayed.



# 3 Connecting the CAN Bus

## 3.1 Connection over D-Sub Connector

After the connection cable has been connected to the CAN interface a CAN bus can be connected to the D-Sub connector. The pin assignment of the D-Sub connector corresponds to the specification CiA® 106:

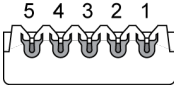
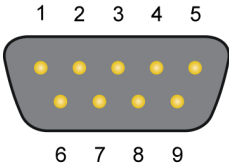
CAN interface	Connection cable		Assignment
SUR header Type: SM05B-SURS-TF	SUR socket Type: 05SUR-32S	D-Sub plug, 9-pin	
			
3	3	3, 6	CAN_GND
4	4	7	CAN_High
5	5	2	CAN_Low
1, 2	1, 2	1, 4, 5, 8, 9	None

## 3.2 Daisy Chain

The daisy chain can be activated via solder jumpers on the board to connect a CAN-FD-optimized connection to an existing CAN bus. This makes interference-free operation possible at higher CAN FD bit rates, because stubs and Y distributions are avoided as far as possible.

### 3.2.1 Connection example and assignment

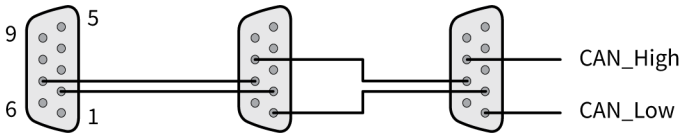
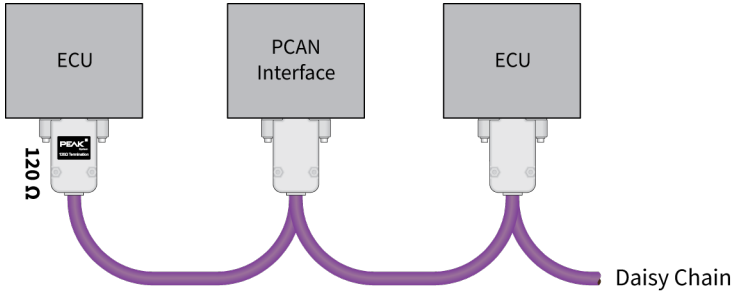

For cabling, the cables and connectors must be assembled accordingly.

D-Sub plug on CAN interface	D-Sub socket on cable	Assignment
1 2 3 4 5	5 4 3 2 1	
6 7 8 9	9 8 7 6	
	1	CAN_Low Daisy Chain
	2	CAN_Low
	3, 6	GND
	7	CAN_High
	8	CAN_High Daisy Chain
	4, 5, 9	None



**Note:** The activation of the daisy chain is optional. The manual is available on request from our customer support. Please contact [support@peak-system.com](mailto:support@peak-system.com).

## 3.3 Internal Termination

For each CAN channel a termination can be activated via solder bridges on the board. This switches a resistor of  $120\ \Omega$  between CAN\_High and CAN\_Low. The conversion is done for an additional improvement of the CAN signal as split termination.



**Note:** The activation of the internal termination is optional. The manual is available on request from our customer support. Please contact [support@peak-system.com](mailto:support@peak-system.com).



**Tip:** We recommend to do termination at the CAN cabling, for example with the terminating resistors PCAN-Term (IPEK-003002) or PCAN-MiniTerm (IPEK-003002-Mini). Thus, CAN nodes can be flexibly connected to the bus.

## 3.4 Cabling

### 3.4.1 Termination

The High-speed CAN bus (ISO 11898-2) must be terminated with  $120\ \Omega$  on both ends. The termination prevents interfering signal reflections and ensures the proper operation of the transceivers of the connected CAN nodes (CAN interfaces, control devices).

### 3.4.2 Example of a Connection

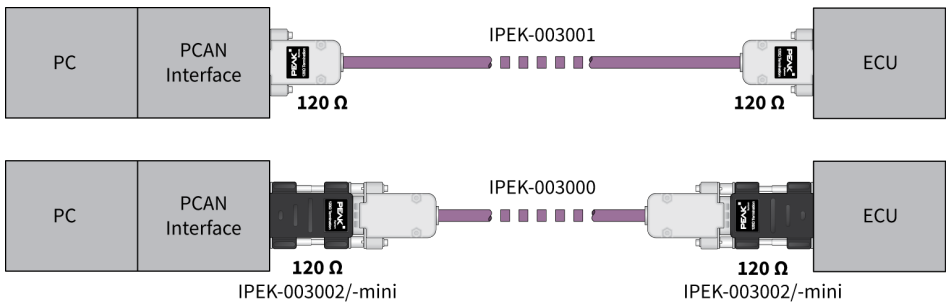

This example shows a connection between the PCAN Interface and a control unit (ECU). The upper example shows a connection with a cable which is terminated with 120 Ω at both ends. At the lower example the connection is made with termination adapters.

### 3.4.3 Maximum Bus Length

The maximum bus length depends primarily on the bit rate:

Nominal bit rate	Buslength
1 Mbit/s	40 m
500 kbit/s	110 m
250 kbit/s	240 m
125 kbit/s	500 m
50 kbit/s	1.3 km
25 kbit/s	2.5 km

The listed values have been calculated on the basis of an idealized system and can differ from reality.



**Note:** For CAN FD, the same maximum bus lengths apply as for CAN, despite the higher data bit rate of CAN FD. The dependency is based on the bit rate during the arbitration, called nominal bit rate.

# 4 CAN Monitor PCAN-View

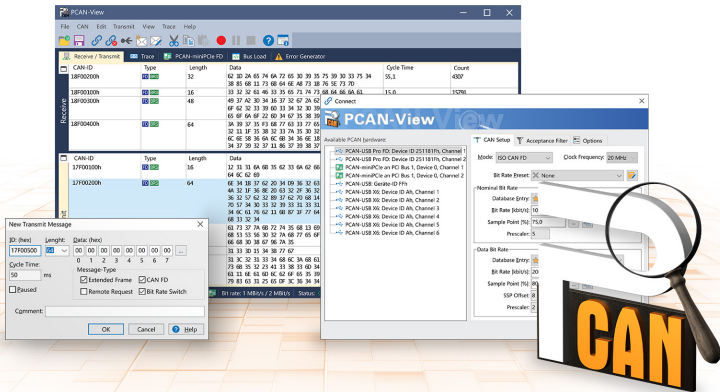

The CAN monitor PCAN-View is a Windows software for viewing, sending, and recording CAN and CAN FD messages. The software is installed with the installation of the device driver package under Windows.

In the following the initialization of a CAN interface is described as an example.

Detailed information about using PCAN-View can be found in the program window under the menu item *Help*.

# 4.1 Initialize CAN interface

1. Open the program *PCAN-View* via the Windows Start menu.

Depending on the CAN interface the *Connect* dialog is displayed with or without settings for CAN FD.

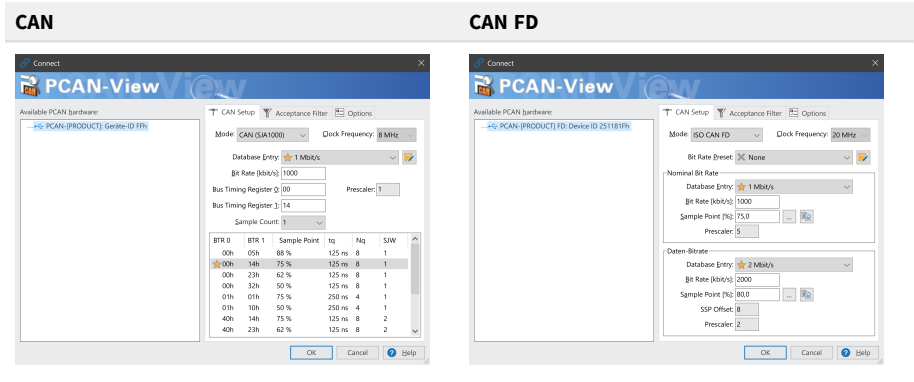

CAN interface	List entry in Available Hardware
USB Interface, 1-channel	see example above
USB Interface, 2-channel	<ul style="list-style-type: none"> <li>PCAN-USB Pro FD: Device ID 251181Fh, Channel 1</li> <li>PCAN-USB Pro FD: Device ID 251181Fh, Channel 2</li> </ul>
PCIe Interface, 2-channel	<ul style="list-style-type: none"> <li>PCAN-PCI Express at PCI Bus 1, Device 0, Channel 1</li> <li>PCAN-PCI Express at PCI Bus 1, Device 0, Channel 2</li> </ul>

2. If there are several CAN interfaces, select the desired interface. For multiple channels, select the desired channel from the list.
3. Enter the *bit rate(s)* and other settings according to the connected CAN bus.
4. Confirm the entries with *OK*. The main window appears and displays the *Receive / Transmit* tab.

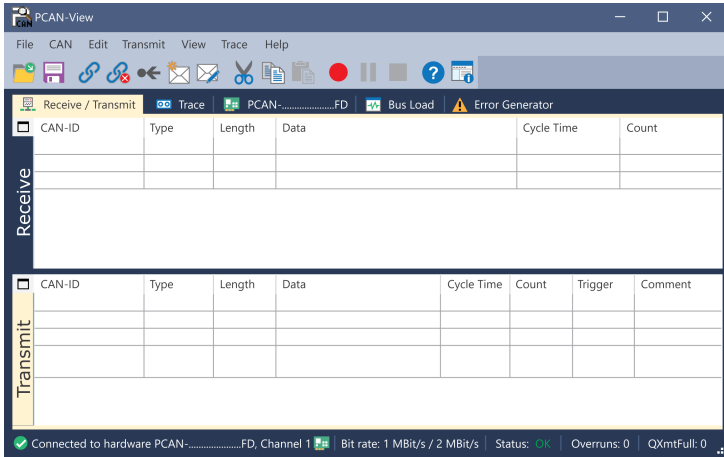

5. For initializing another channel or CAN interface, open another instance of *PCAN-View*.

## 4.2 Transmit CAN message

1. Select the menu command *Transmit / New Message*.

Depending on the CAN interface, the dialog box *New Transmit Message* is displayed with or without settings for CAN FD.

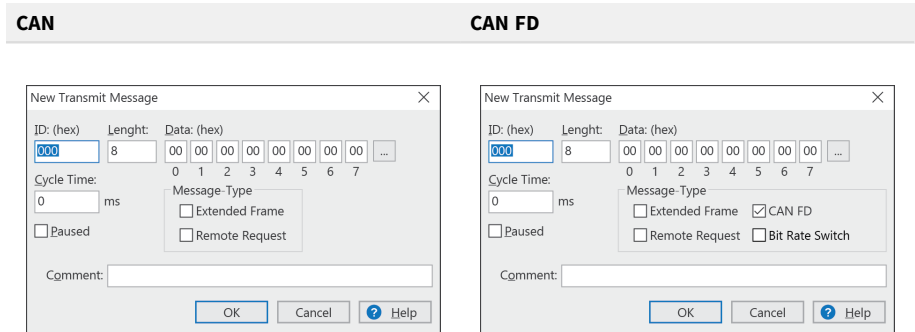

1. Enter the *ID*, *Length* and *Data* of the message. Other settings can be made according to the connected CAN bus.

2. Enter a value into the *Cycle Time* field to choose manually or periodically message transmission.

To transmit periodically enter a value greater than 0.

To transmit only manually enter the value 0.

3. Confirm the entries with *OK*.

The created transmit message appears on the *Receive / Transmit* tab.

4. To send the message manually, select the menu command *Transmit > Send* or press the **space** bar.

The manual transmission process is performed additionally for periodically transmitted CAN messages.



## 4.3 Additional Tabs

Depending on the CAN interface, additional tabs are available.

### 4.3.1 Trace Tab

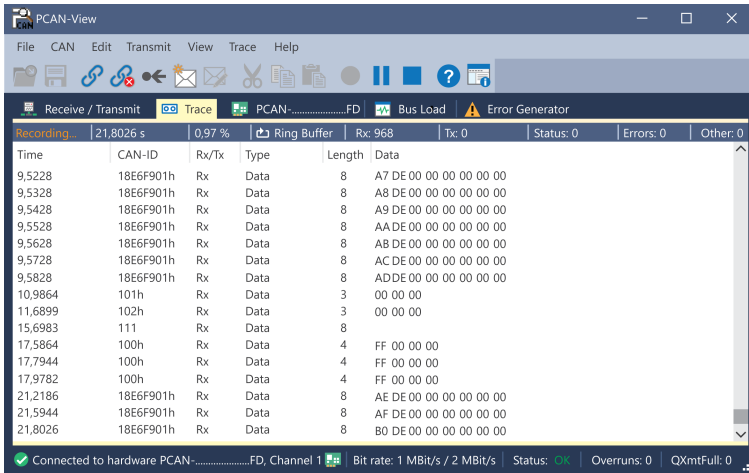

The tracer (data logger) records the communication of the CAN bus in linear or ring buffer mode. The trace data can be saved to a file.

## 4.3.2 CAN Interface Tab

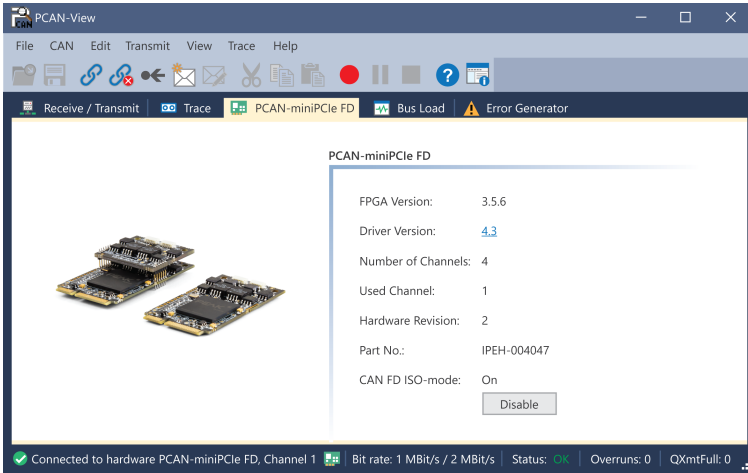

The *CAN interface* tab shows information about the hardware and the used Windows device driver. In this case exemplary for the PCAN-miniPCle FD. Depending on the CAN interface, a hardware ID can be determined to distinguish several interfaces of the same type.

### 4.3.3 Bus Load Tab

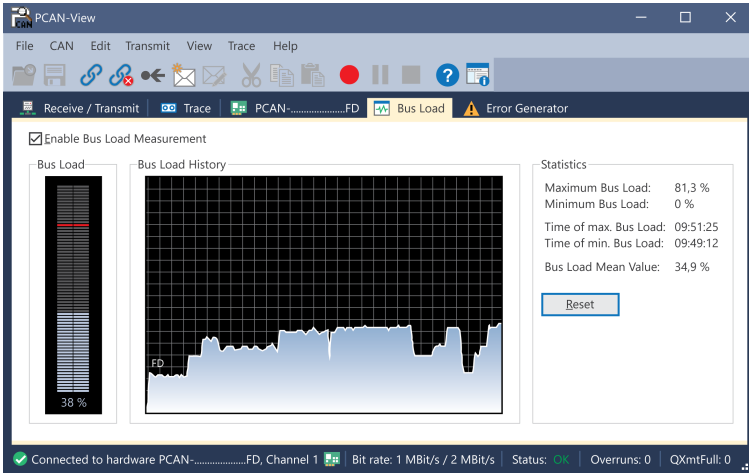

The *Bus Load* tab displays the current bus load, its time history and statistical information of the connected CAN channel.

## 4.3.4 Error Generator Tab

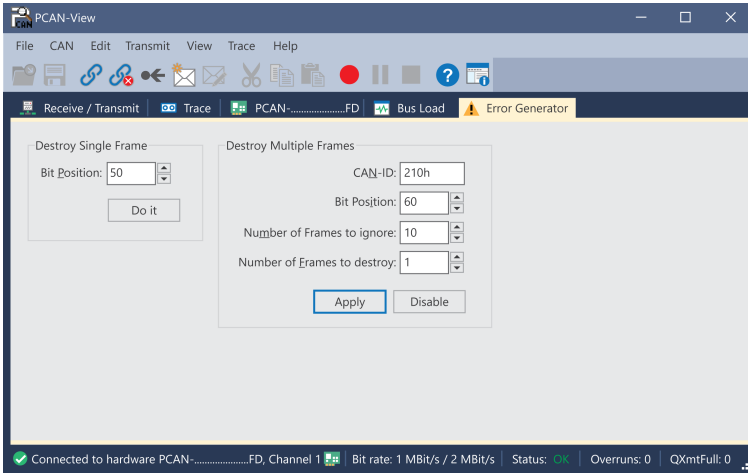

Via the *Error Generator* tab the communication on the CAN bus in test environments or during the development of CAN buses can be disturbed in a controlled way by 6 consecutive dominant bits. This is a violation of the CAN protocol on the CAN bus which must be recognized as an error by the connected CAN nodes.



**Note:** The Error Generator should only be used by experienced users and in the development environment. For further information, please contact our customer support: [support@peak-system.com](mailto:support@peak-system.com)

You can destroy CAN frames with the error generator by one of two methods:

- once after activation
- repeatedly at specific intervals related to a CAN ID

## Destroy Single CAN Frame

The *Destroy Single Frame* area refers to the next CAN frame that is recognized after activation.

1. Enter the *Bit Position* where in the CAN frame the error is to be generated. The bit position must start after the identifier. The count includes the stuff bits.
2. Execute the destroy action with *Do it*.

The next received or transmitted CAN frame will be destroyed at the selected bit position.

## Destroy Multiple CAN Frames

1. Enter the *CAN ID* of the CAN frame that is intended to be destroyed multiple times. The following specifications refer to this ID.
2. Enter the *Bit Position* where in the CAN frame the error is to be generated. The bit position must start after the identifier. The count includes the stuff bits.
3. If CAN messages are to be sent unharmed before being destroyed, specify the *Number of Frames to ignore*.
4. Determine the *Number of Frames to destroy*.
5. Confirm the entries with *Apply* to activate the error generator.
6. Stop destroying further CAN frames with *Disable*.

# 5 API PCAN-Basic

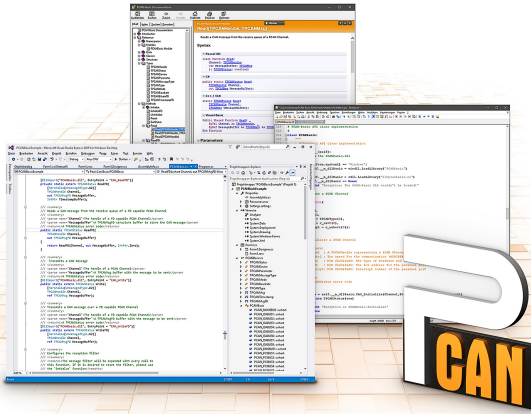

The intended use of PCAN-Basic requires compliance with the license rights. Read the license agreement for end users at:

<https://www.peak-system.com/quick/eula>

The programming interface (API) PCAN-Basic provides basic functions for the connection of own programs to the CAN and CAN FD Interfaces of PEAK-System. PCAN-Basic is the interface between the program and the device driver. In Windows operating systems this is a DLL (Dynamic Link Library) and in Linux operating systems an SO (Dynamic Shared Object). PCAN-Basic is designed to be cross-operating system compatible. Software projects can be ported between supported systems with little effort.

With the installation of the device driver package under Windows the DLL files of the API PCAN-Basic are placed in the system folder. Examples for all common programming languages as well as libraries and help files are available as a download package at: [www.peak-system.com/quick/DL-Develop-E](http://www.peak-system.com/quick/DL-Develop-E)

For Linux, a download of the API is available under this link. For a use of PCAN-Basic another driver package with a chardev driver is needed, because an access under SocketCAN is not possible. The "Driver Package for Proprietary Purposes", the user manual, and further information about the implementation can be found at [www.peak-system.com/linux](http://www.peak-system.com/linux).

## 5.1 Features of PCAN-Basic

- API for developing applications with CAN and CAN FD connections
- Support for CAN specifications 2.0 A/B and FD
- Application development for the platforms Windows 11 (x64/ARM64), 10 (x64), and Linux
- Multiple PEAK-System applications and your own can be operated on a physical channel at the same time
- Use of a single DLL for all supported hardware types
- Use of up to 16 channels for each hardware type (depending on the PEAK CAN interface used)
- Simple switching between channels of a PEAK CAN interface
- Access to the CAN channels of a PCAN-Gateway via the new PCAN-LAN hardware type
- Driver-internal buffering of up to 32,768 CAN messages per CAN channel
- Precision of time stamps on received messages up to 1  $\mu$ s (depending on the PEAK CAN interface used)
- Supports PEAK-System's trace formats version 1.1 and 2.0 (for CAN FD applications)
- Access to specific hardware parameters, such as listen-only mode
- Notification of the application through Windows® events when a message is received
- Support of CAN error frames
- Confirmation of physical transmission by CAN echo frames
- Extended system for debugging operations
- Multilingual debugging output
- Output language depends on operating system
- Debugging information can be defined individually
- Thread-safe API

## 5.2 Principle Description of the API

The sequence of accessing the CAN interface is divided into three phases:

### Initialization

A CAN channel must be initialized before using it. This is done by the simple call of the function `CAN_Initialize` for CAN and `CAN_InitializeFD` for CAN FD. Depending on the type of the CAN hardware, up to 16 CAN channels can be opened at the same time. After a successful initialization the CAN channel is ready. No further configuration steps are required.

### Interaction

For receiving and transmitting messages the functions `CAN_Read` and `CAN_Write` as well as `CAN_ReadFD` and `CAN_WriteFD` are available depending on the initialization mode. Additional settings can be made, such as setting up message filters to confine to specific CAN IDs or setting the CAN controller to Listen-only mode.

When receiving CAN messages, events are used for an automatic notification of an application (client). This offers the following advantages:

- The application no longer needs to check for received messages periodically (no polling).
- The response time at reception is reduced.

### Completion

To end the communication the function `CAN_Uninitialize` is called in order to release the reserved resources for the CAN channel, among others. In addition the CAN channel is marked as "Free" and is available to other applications.



# 6 Technical Data

## Connections

CAN connection cable	<b>Connection side</b>	<b>Connection type</b>
	CAN bus	D-Sub (m), 9-pin, pin assignment according to CiA® 106
	CAN interface	05SUR-32S (www.jst-mfg.com)
CAN socket on CAN interface	Type: SM05B-SURS-TF	
Computer	PCI Express Mini slot, 52-pin; electromechanical specifications 1.1 and 1.2; uses PCIe-lane	

## CAN (FD)

Protocols	CAN and CAN FD according to ISO 11898-1; non-ISO CAN FD	
Physical transmission	ISO 11898-2 (High-speed CAN)	
Transceiver	NXP TJA1044GT	
CAN bit rates	Nominal:	25 kbit/s to 1 Mbit/s
CAN FD bit rates	Nominal:	25 kbit/s to 1 Mbit/s
	Data:	25 kbit/s to 12 Mbit/s
Controller	FPGA implementation	
Time stamp resolution	1 µs	
Galvanic isolation	up to 300 V, separate for each CAN connector	
Internal termination	Not activated at delivery. Soldering manual on request: support@peak-system.com	
Daisy Chain	Not activated at delivery. Soldering manual on request: support@peak-system.com	

## Power supply

Max. current consumption at 1.5 V pin	Single Channel	350 mA
	Dual Channel	350 mA
	Quad Channel	350 mA
Max. current consumption at 3.3 V pin	Single Channel	100 mA
	Dual Channel	150 mA
	Quad Channel	250 mA

## Measures

Size (W x L x H)	Single Channel	30 x 51 x 4.6 mm
	Dual Channel	30 x 51 x 4.6 mm
	Quad Channel	30 x 51 x 12 mm
Length connection cable	20 cm (default length), other cable lengths on request	
Weight	Single Channel	8 g
	Dual Channel	8 g
	Quad Channel	11 g
	Connection cable	7 g (each)
	Screw for D-Sub connector	1 g (each)

## Environment

Operating temperature	-40 to +85 °C (-40 to +185 °F)
Temperature for storage and transport	-40 to +100 °C (-40 to +212 °F)
Relative humidity	15 to 90 %, not condensing

## Conformity

RoHS	EU-Directive 2011/65/EU (RoHS 2) + 2015/863/EU DIN EN IEC 63000:2019-05
EMC	EU-Directive 2014/30/EU DIN EN 55032:2022-08 DIN EN 55035:2018-04

# Appendix A CE Certificate

## EU Declaration of Conformity



This declaration applies to the following product:

Product name: **PCAN-miniPCIe FD**  
Item number(s): **IPEH-004045, IPEH-004046, IPEH-004047**  
Manufacturer: **PEAK-System Technik GmbH**  
**Leydheckerstraße 10**  
**64293 Darmstadt**  
**Germany**



We declare under our sole responsibility that the mentioned product is in conformity with the following directives and the affiliated harmonized standards:

**EU Directive 2011/65/EU (RoHS 2) + 2015/863/EU (amended list of restricted substances)**

**DIN EN IEC 63000:2019-05**

Technical documentation for the assessment of electrical and electronic products with respect to the restriction of hazardous substances (IEC 63000:2016);  
German version of EN IEC 63000:2018

**EU Directive 2014/30/EU (Electromagnetic Compatibility)**

**DIN EN 55032:2022-08**

Electromagnetic compatibility of multimedia equipment - Emission requirements (CISPR 32:2015);  
German version of EN 55032:2015 + AC:2016 + A11:2020 + A1:2020

**DIN EN 55035:2018-04**

Electromagnetic compatibility of multimedia equipment - Immunity requirements (CISPR 35:2016, modified);  
German version of EN 55035:2017

Darmstadt, 7 June 2024

A handwritten signature in black ink, appearing to read "Uwe Wilhelm".

Uwe Wilhelm, Managing Director

# Appendix B UKCA Certificate

## UK Declaration of Conformity



This declaration applies to the following product:

Product name: **PCAN-miniPCIe FD**  
Item number(s): **IPEH-004045, IPEH-004046, IPEH-004047**

<b>Manufacturer:</b> PEAK-System Technik GmbH Leydheckerstraße 10 64293 Darmstadt Germany	<b>UK authorized representative:</b> Control Technologies UK Ltd Unit 1, Stoke Mill, Mill Road, Sharnbrook, Bedfordshire, MK44 1NN, UK
-------------------------------------------------------------------------------------------------------	----------------------------------------------------------------------------------------------------------------------------------------------------



We declare under our sole responsibility that the mentioned product is in conformity with the following UK legislations and the affiliated harmonized standards:

### The Restriction of the Use of Certain Hazardous Substances in Electrical and Electronic Equipment Regulations 2012

#### DIN EN IEC 63000:2019-05

Technical documentation for the assessment of electrical and electronic products with respect to the restriction of hazardous substances (IEC 63000:2016);  
German version of EN IEC 63000:2018

### Electromagnetic Compatibility Regulations 2016

#### DIN EN 55032:2022-08

Electromagnetic compatibility of multimedia equipment - Emission requirements (CISPR 32:2015);  
German version of EN 55032:2015 + AC:2016 + A11:2020 + A1:2020

#### DIN EN 55035:2018-04

Electromagnetic compatibility of multimedia equipment - Immunity requirements (CISPR 35:2016, modified);  
German version of EN 55035:2017

Darmstadt, 7 June 2024

Uwe Wilhelm, Managing Director

# Appendix C Dimension Drawings

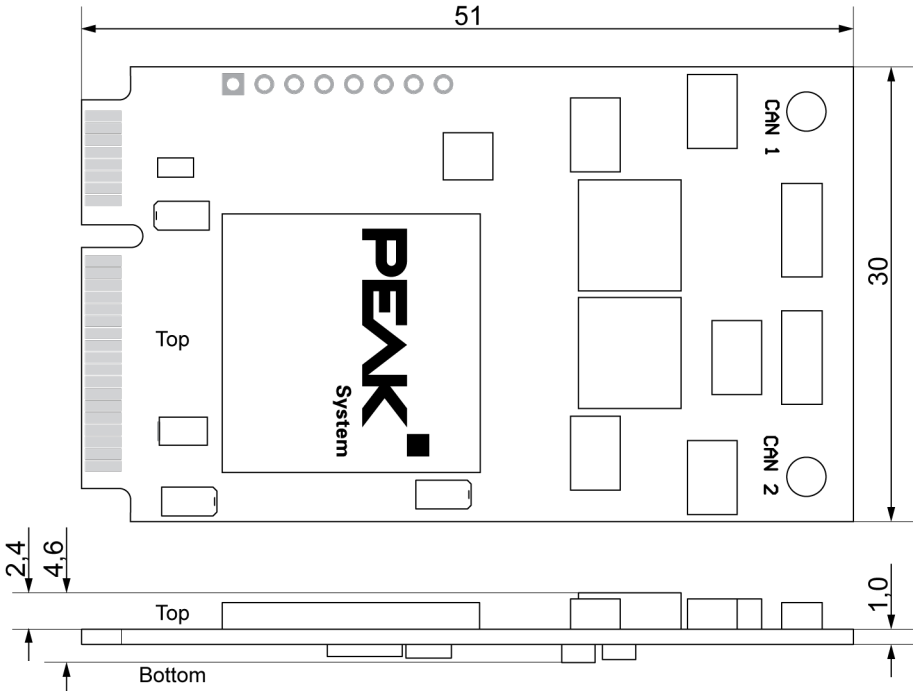

Dimensions in mm of PCAN-miniPCle FD Single Channel and Dual Channel.

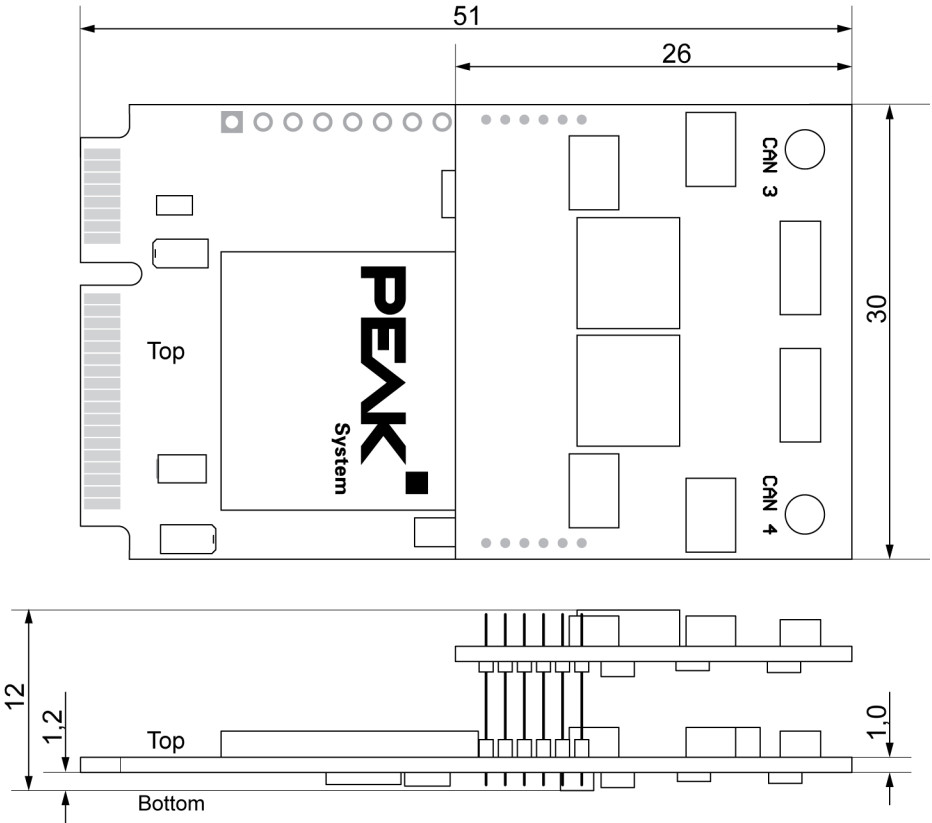

Dimensions in mm of PCAN-miniPCIe FD Quad Channel.

# Appendix D Quick Reference

## Software/Hardware Installation under Windows

Download the device drivers installation package from our website [www.peak-system.com/quick/DL-Driver-E](http://www.peak-system.com/quick/DL-Driver-E). Install the driver before you install the CAN interface.

Turn off the computer and insert the PCAN-miniPCIe FD into an available PCI Express Mini slot (using PCIe lane).

The new hardware is detected at the next Windows start and the driver is initialized. Check the operational readiness. Open the Windows Start menu. Type `Peak Settings` and press `Enter`. The window *PEAK settings* appears. The connected CAN interface is displayed under *CAN Hardware*.

## Getting Started under Windows

Run the CAN monitor PCAN-View from the Windows Start menu as a sample application for accessing the CAN interface. For initialization of the CAN interface select the desired CAN channel and CAN bit rate.

## Pin assignment

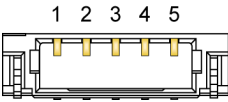
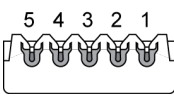
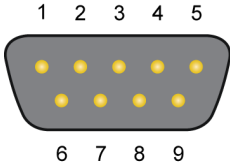
CAN interface	Connection cable		Assignment
	SUR header Type: SM05B-SURS-TF	SUR socket Type: 05SUR-32S	
			
3	3	3, 6	CAN_GND
4	4	7	CAN_High
5	5	2	CAN_Low
1, 2	1, 2	1, 4, 5, 8, 9	None

# Appendix E Linux

Depending on the Kernel version, device drivers for the CAN interfaces from PEAK-System are already included in the operating system. The PCAN interfaces are handled as network devices (SocketCAN, netdev). You can find the documentation for SocketCAN under:

<https://www.kernel.org/doc/Documentation/networking/can.txt>

The following command lists the available drivers:

```
grep PEAK_ /boot/config-`uname -r`
```

Whether the required driver for the PCAN interface is present and loaded can be checked with the following command:

```
lsmod | grep ^peak check
```

If the initialization was successful, the response line starts with `peak_pci`.

You can find a recent list of which PCAN interface is supported from which kernel version onwards on our Linux website.

If the required drivers are not listed, install the "Driver Package for Proprietary Purposes". The download and documentation for the driver can also be found on: [www.peak-system.com/linux](http://www.peak-system.com/linux)

This driver package is also needed to use the APIs based on the chardev driver, for example PCAN-Basic, libpcan, or libpcanfd.



# Appendix F Disposal

The product must not be disposed of in household waste. Dispose of the product properly in accordance with local regulations.