

SPECIFICATION CONTROL DRAWING

THIS DRAWING CONTAINS INFORMATION PROPRIETARY TO RF INDUSTRIES, LTD. ANY UNAUTHORIZED USE OF THIS DRAWING IS EXPRESSLY PROHIBITED. ANY VIOLATION IS PUNISHABLE UNDER U.S. COPYRIGHT LAWS.

REV	DESCRIPTION	DWN	DATE	APPROVED
A	ENGINEERING RELEASE	CZS	9/22/97	R. RICE
B	CHANGE DIELECTRIC ID	CZS	5/1/98	R. RICE

000000

ALL DIMENSIONS ARE REFERENCE ONLY

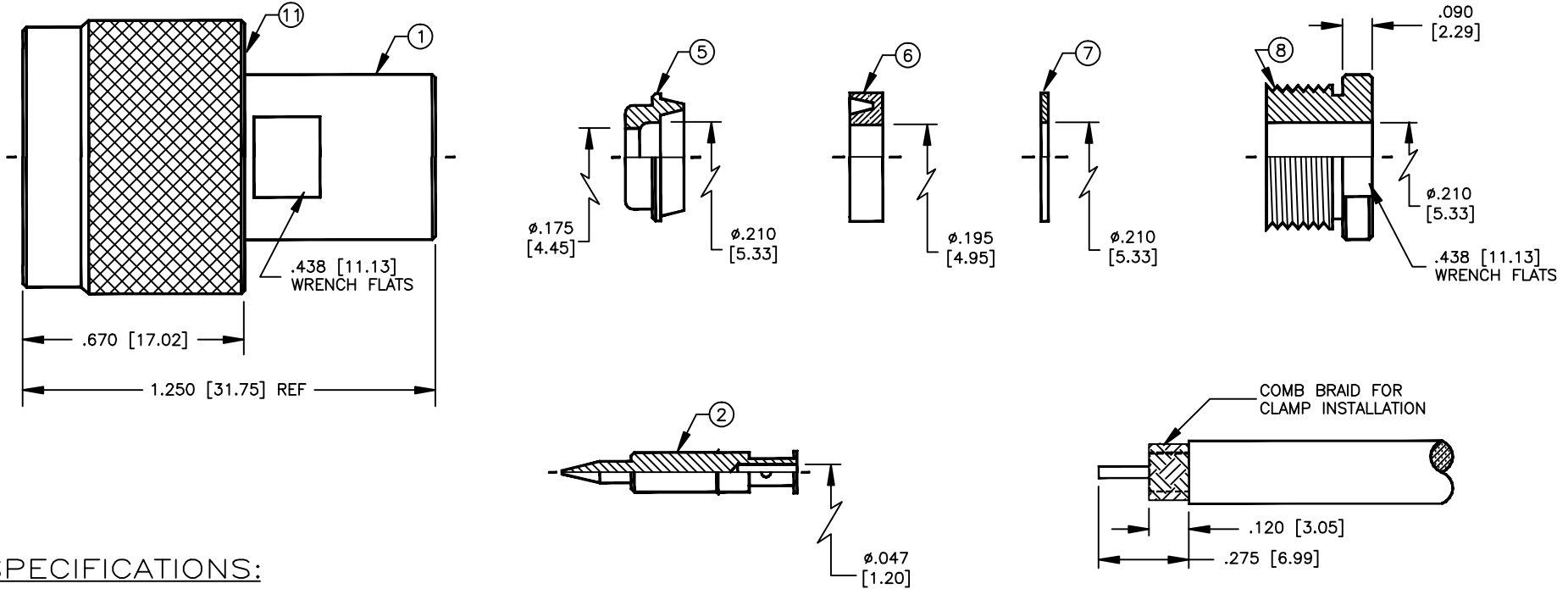

SPECIFICATIONS:

IMPEDANCE: 50 OHMS
 WORKING VOLTAGE: 1000 VRMS @ SEA LEVEL
 FREQUENCY RANGE: 0-11 GHz
 INSERTION LOSS: ≤ -.2 dB @ 10 GHz
 VSWR MAX: 1.3:1 @ 9 GHz
 FOR TIMES LMR-200, LMR-200 ULTRAFLEX, ALPHA 9848 & MSI-22

SUGGESTED STRIPPING INSTRUCTIONS
 SUGGESTED CRIMP DIE: .068

ITEM	DESCRIPTION	QTY	MATERIAL	FINISH
11	SHELL	1	BRASS	NICKEL
10	GASKET	1	S.I.RUBBER	RED
9	RETAINING RING	1	SK-5	NONE
8	BACK NUT	1	BRASS	NICKEL
7	WASHER	1	BRASS	NICKEL
6	GASKET	1	S.I.RUBBER	RED
5	CLAMP	1	BRASS	NICKEL
4	GROUND RING	1	BRASS	NICKEL
3	DIELECTRIC	1	PTFE	NONE
2	PIN (PIN-3C2-10)	1	BRASS	GOLD
1	BODY	1	BRASS	NICKEL

DIMENSIONS ARE IN INCHES AND [MILLIMETERS]	
UNLESS OTHERWISE NOTED TOLERANCES ARE:	
DECIMALS	DIAMETER
DRAWN C. ZUNIGA	5/1/98
CHECKED	
ORJ DRAWN C. ZUNIGA	9/22/97
APPROVALS	DATE

RF connectors
 DIVISION OF RF INDUSTRIES, LTD.

7610 MIRAMAR RD
 SAN DIEGO, CA 92126
 (619)549-6340
 (619)549-6345 FAX

RFN-1000-C2

N MALE CLAMP PLUG

SIZE A	CABLE GROUP C2	DWG NO. 8760	REV B
SCALE: 2:1		CAD FILE 13ARC B	SHEET 1 OF 1