

# EMOSAFE EN-76

Product Datasheet

## Ultra-compact Network Isolators



## 1 FEATURES AND ADVANTAGES

- Conforms to IEC 60601-1
- Suitable for use within medical supply units
- UL Recognized Component
- RoHS compliant
- Suitable for devices with supply voltages up to 400 V AC
- Dielectric strength 6.0 kV AC or 8.5 kV DC
- Transient voltage suppression on all signal lines
- ISO/IEC 11801 Class EA as well as TIA/EIA-568 Cat 6A Ethernet Performance
- Extremely low insertion losses; thereby total cable lengths of 100 metres are achievable
- Ultra-compact
- Suitable for stand-alone operation as well as incorporation into racks, devices, and products
- 100% inspection by our Quality Control

## 2 GENERAL DESCRIPTION

EMOSAFE EN-76 network isolators interrupt the electrically conductive connection (wires and shield) between devices that are connected to each other via copper-guided Ethernet cabling. They prevent equipotential bonding currents and protect connected devices and their users from transient over voltages that have been directly or inductively coupled into the network cable because of installation errors, lightning, switching operations, or electrostatic discharges.

Built into a medical electrical (ME) product, the EMOSAFE EN-76 Network Isolator facilitates the safe Ethernet connection of this ME product within the patient environment. The EN-76 satisfies all construction requirements of IEC 60601-1 in the formation of two means of patient protection (MOPP) within the network interface, thereby practically eliminating the risk of electrical shocks arising from such stray external voltages at the network connection. With its UL approval, the EN-76 is also suitable for devices destined for export to the North American markets.

The EMOSAFE EN-76 is an efficient and compact 10Gigabit Ethernet network isolator, characterised by exceptional Ethernet performance and a very high dielectric withstanding voltage. As a Keystone module, it can be used in all Keystone-compatible outlet sockets, patch panels, and panel cut-outs. The construction with socket and cable stub provides the physical functionality of an extension cable.







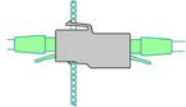

The EMOSAFE EN-76 Network Isolator transmits high-frequency signals through the principle of electromagnetic induction. This results in the EN-76 not requiring any external power supply. There are no software drivers to be installed.

### 3 APPLICATIONS

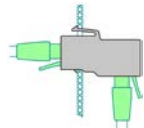
---

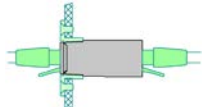
- **Patient protection**  
Electrical separation of Ethernet interfaces of medical electrical (ME) devices and systems, where patients must be protected from dangerous leakage currents, in conformity with applicable standards.
- **Equipment protection**  
Applications, in which valuable devices or those requiring special protection need to be protected against ripple, mains hum, and surge voltages from the network periphery.
- **Measurement technology**  
Electrical measuring and monitoring equipment, which needs to be protected against external voltages and interference voltages arising from the Ethernet periphery.
- **Potential differences (Technical building systems)**  
Computer systems, which are electrically connected with each other over significant distances via Ethernet cabling, where current flows caused by potential differences must be prevented.
- **Audio**  
Audio applications, in which the transmission of low frequency alternating current voltages (mains hum) over the network connection is to be reduced to an imperceptible level.
- **Power over Ethernet (PoE)**  
Network isolators of type EN-76 can be used in a PoE network without restrictions, but PoE end devices cannot be supplied with voltage behind the location of the galvanic isolation.

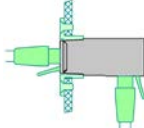
## 4 SUMMARY OF VARIANTS

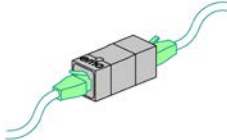
<h1>EN-76</h1> <p><i>Ultra-compact Network Isolators</i></p>	<b>Name</b> Article number	<b>Special features</b>	TVS-Diodes	<b>Configuration</b>
<p><b>Keystone (horizontal)</b></p> 	<p><b>EN-76HE-K</b> A10179</p>	<p>For use in Keystone-compatible outlets. Straight connector</p>	<p>✓</p>	
<p><b>Keystone (vertical)</b></p> 	<p><b>EN-76VE-K</b> A10180</p>	<p>For use in Keystone-compatible outlets. 90° connector</p>	<p>✓</p>	
<p><b>SnapFit (horizontal)</b></p> 	<p><b>EN-76HE-S</b> A10175</p>	<p>For use with EMOSAFE SnapFit accessories. Straight connector</p>	<p>✓</p>	
<p><b>SnapFit (vertical)</b></p> 	<p><b>EN-76VE-S</b> A10176</p>	<p>For use with EMOSAFE SnapFit accessories. 90° connector</p>	<p>✓</p>	
<p><b>Standard</b></p> 	<p><b>EN-76HE</b> A10174</p>	<p>For easy upgrade of existing equipment.</p>	<p>✓</p>	

5 DRAWINGS

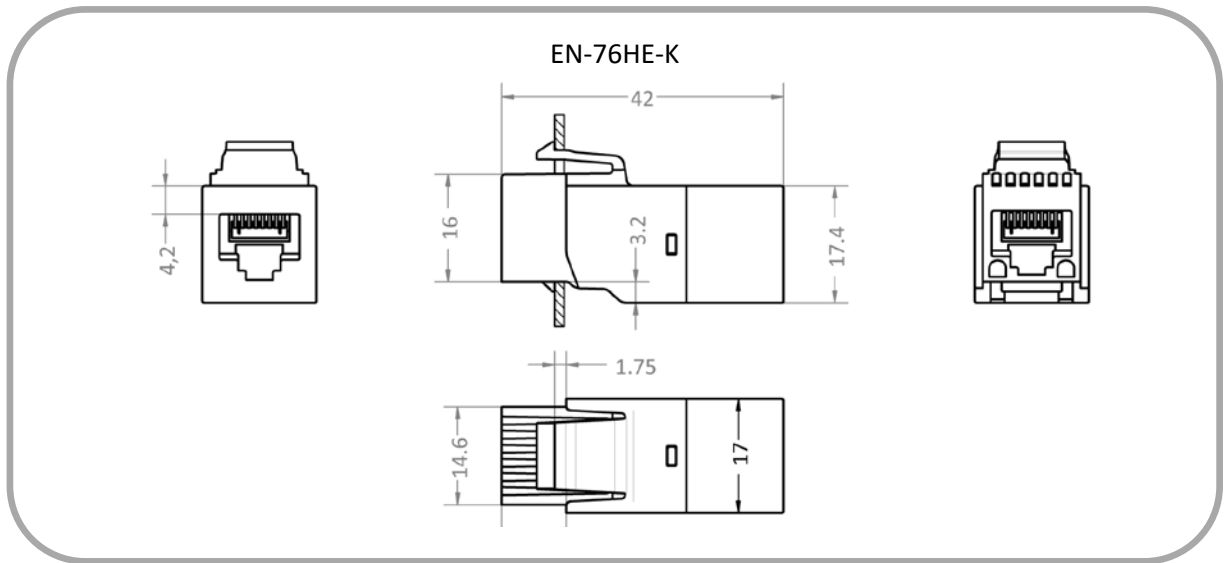

Figure 1 Technical drawings for EN-76HE-K. All dimensions are in millimetres.

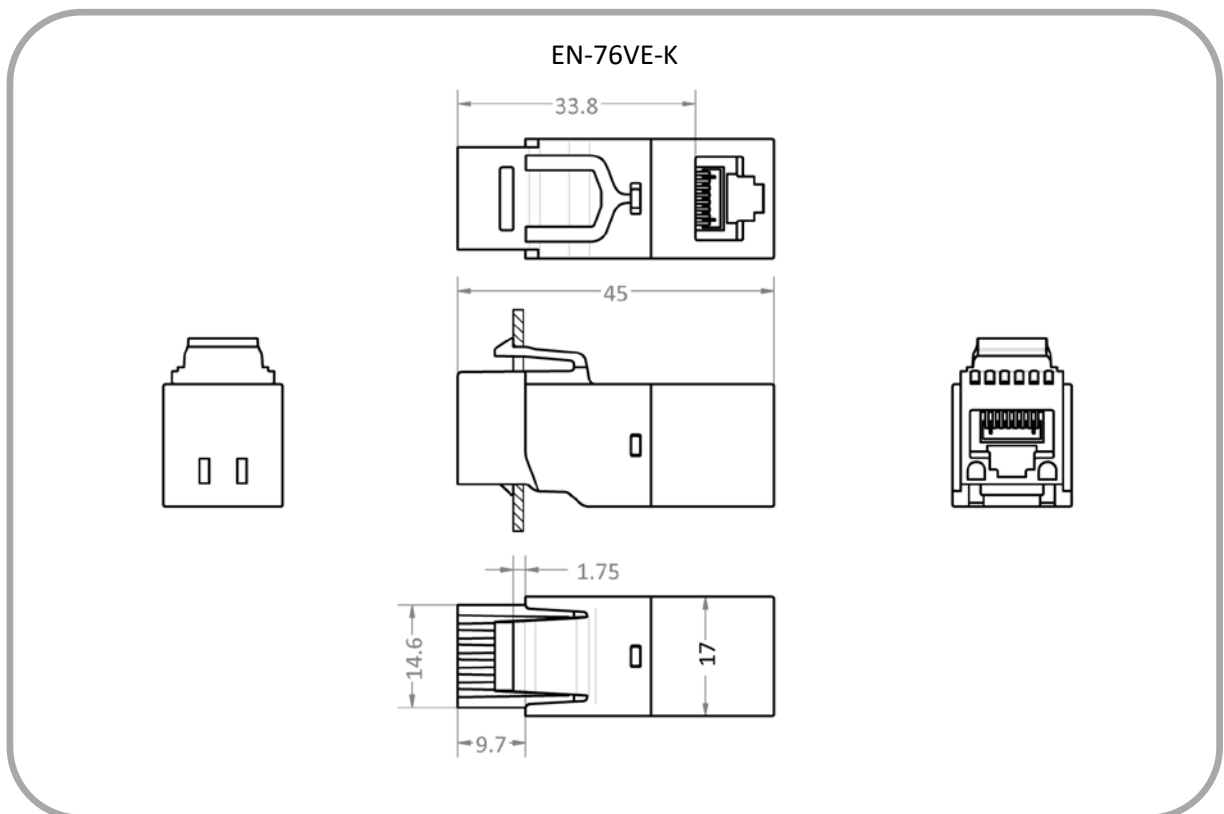

Figure 2 Technical drawings for EN-76VE-K. All dimensions are in millimetres.

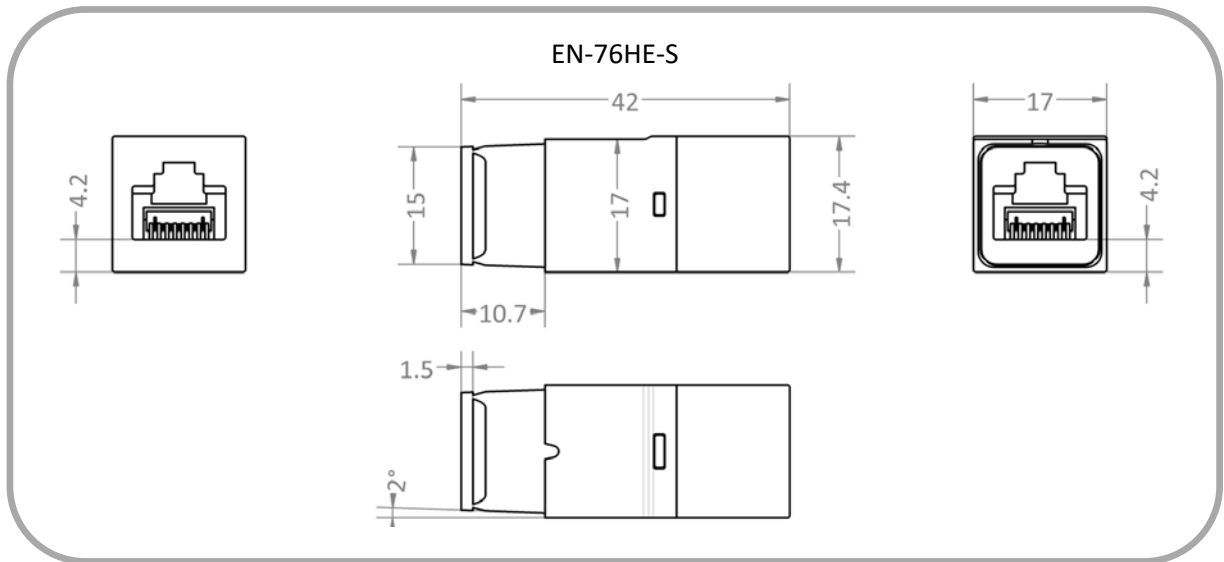

Figure 3 Figure 1 Technical drawings for EN-76HE-S. All dimensions are in millimetres.

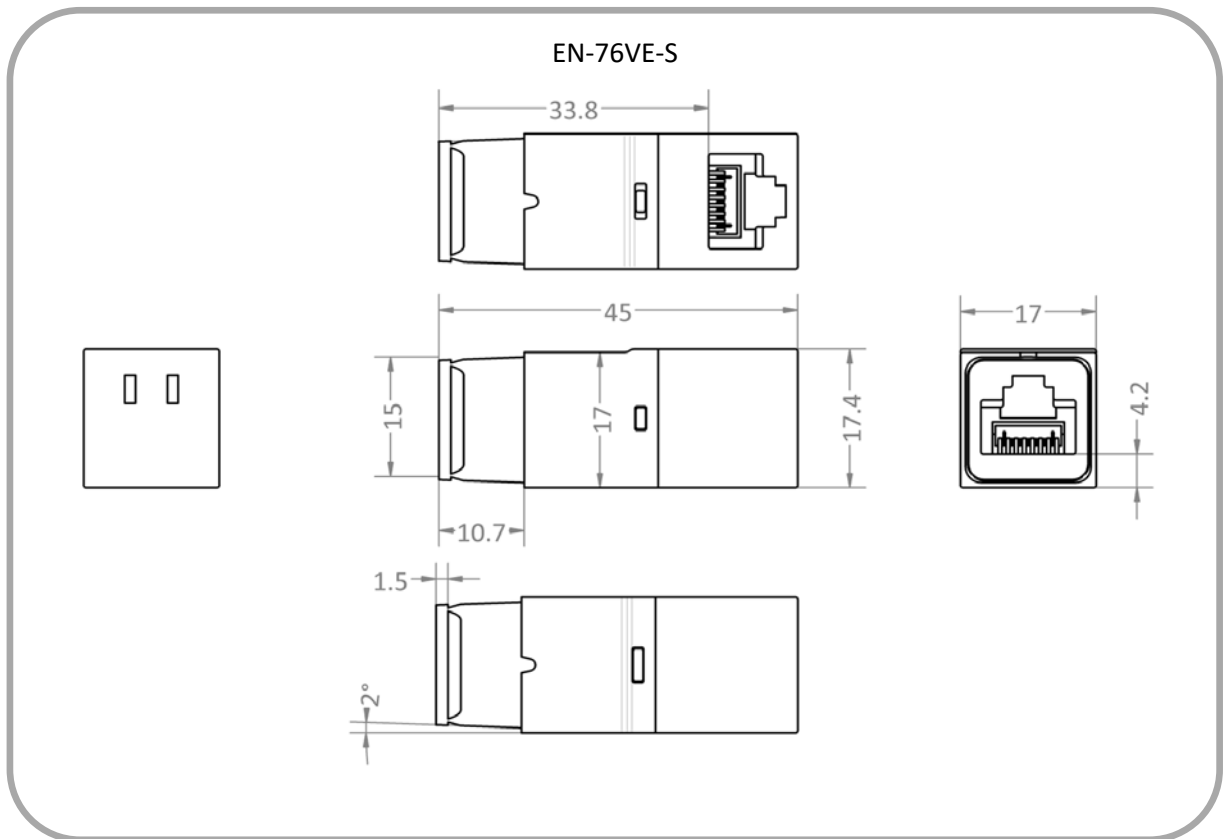

Figure 4 Technical drawings for EN-76VE-S. All dimensions are in millimetres.

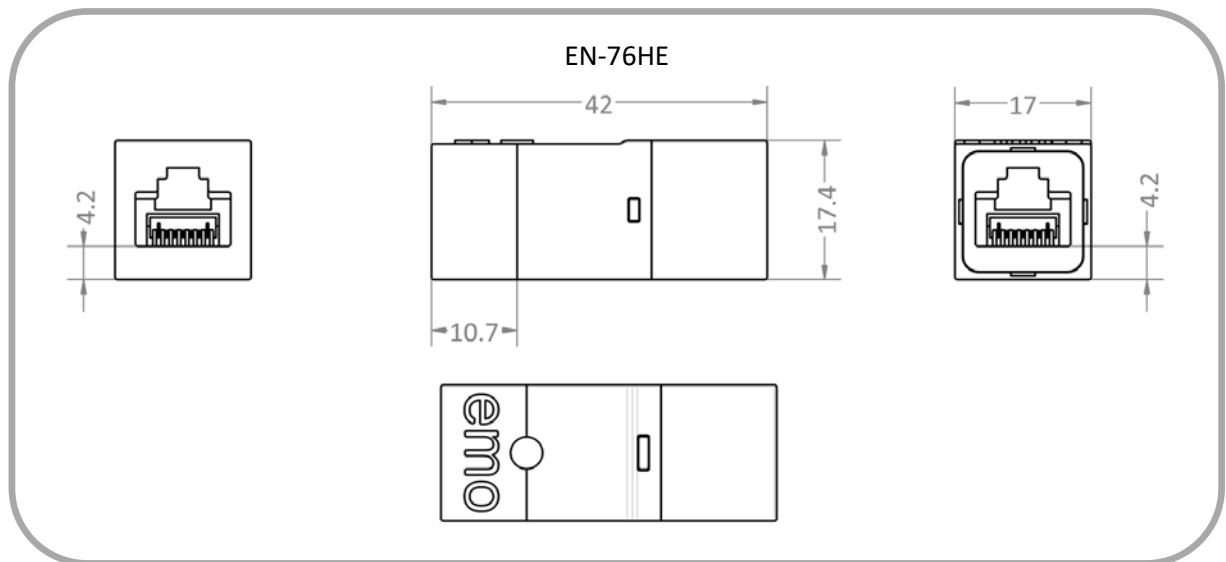





Figure 5 Technical drawings for EN-76HE. All dimensions are in millimetres.

6 ACCESSORIES

6.1 OVERVIEW

SnapFit installation frames are available as accessories for the EN-76HE-S and EN-76VE-S; providing panel mounting which is secure and free from play. The physically square interface allows for four different attachment positions. The production of customer specific SnapFit frames is possible upon request.

**ATTENTION:** *SnapFit installation frames are no longer removable after being snapped into place. Therefore please pay attention to the correct plug-in position when assembling!*

<h2>SnapFit</h2> <p>Installation frame for SnapFit variants</p>	<p>Name</p> <p>Article number</p>	<p>Special features</p>	<p>Configuration</p>
	<p><b>Z-3-SF-INT</b></p> <p>A10057</p>	<ul style="list-style-type: none"> <li>Housing assembly for flush mounting</li> <li>Two M2.5 brass inserts</li> <li>Two snap-fit positions</li> <li>Material: polyamide, black</li> </ul>	
	<p><b>Z-4-SF-EXT</b></p> <p>A10058</p>	<ul style="list-style-type: none"> <li>Protruding housing assembly</li> <li>Two snap-fit positions</li> <li>Material: polyamide, black</li> </ul>	

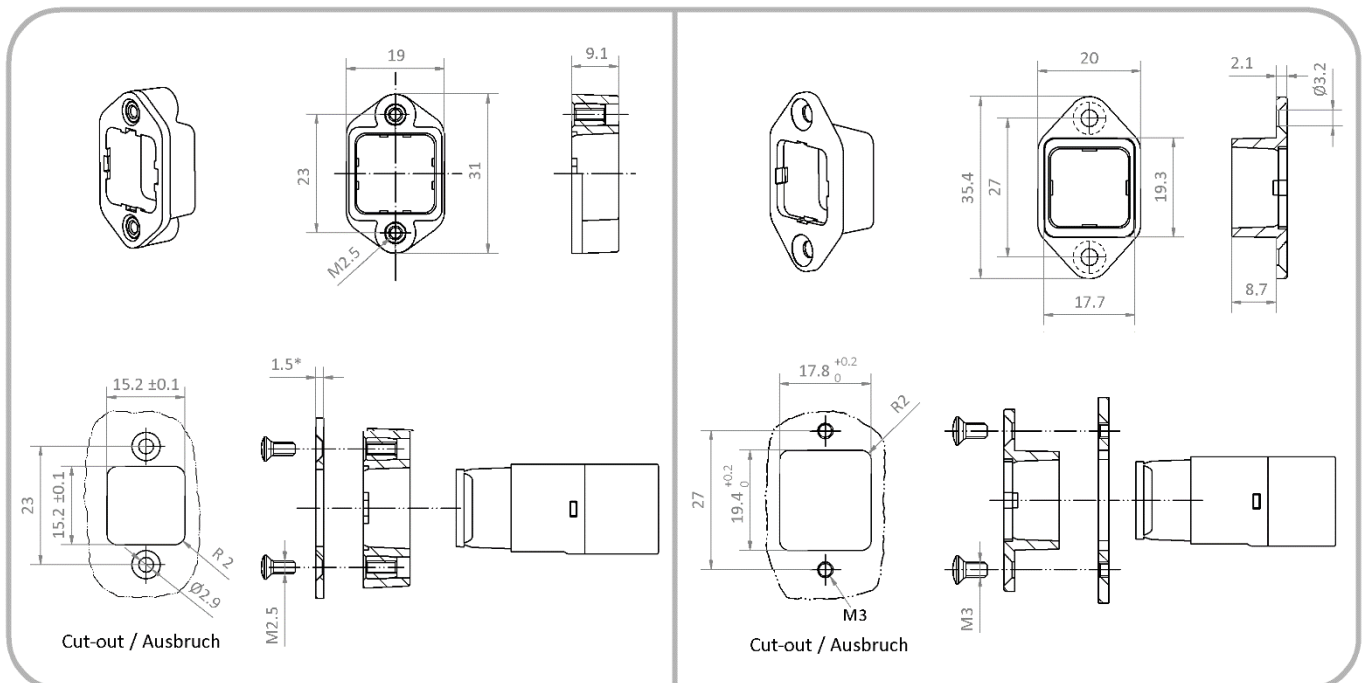

Figure 6 Physical dimensions and required cut-out for SnapFit installation frames. All dimensions are in millimetres.  
 \* 1.5mm is recommended for a flush surface mounting. Other plate thicknesses are possible.

## 7 INSTALLATION INFORMATION

### 7.1 EQUIPMENT INSTALLATION

When designing Network Isolators into equipment or devices, it is essential that the manufacturer observes the applicable creepage and clearance distances. Specifically, the creepage and clearance distances between exposed metal surfaces of Ethernet patch cables plugged into the Network Isolator, and the next-closest electrically conducting components of the equipment or device to be protected. These distances must be designed to comply with the relevant requirements and standards. If needs be, this next-closest electrically conducting component must be appropriately bonded to the protective earth connection.

### 7.2 EN-76HE-K AND EN-76VE-K

EN-76HE-K and EN-76VE-K Network Isolators can be snapped into any housing aperture which satisfies the Keystone dimension requirements.

The Network Isolators also disconnect the shield connections in Ethernet cabling. If the cable shield of the incoming data cable is to be connected with the room or equipment potential, such a connection must be carried out separately before the Network Isolator, effectively bypassing the Network Isolator.

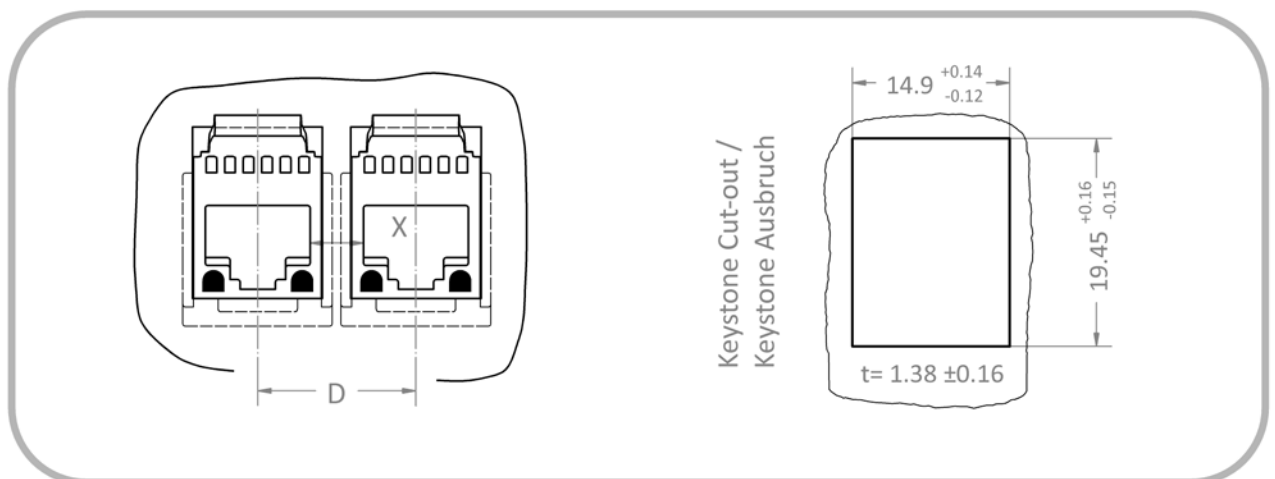

Figure 7. Mechanical dimensions for Keystone-compatible cut-outs, and required panel thickness.

The centre-to-centre separation "D" between two neighbouring Network Isolators is to be selected depending on the necessary clearance and creepage distance. Here, as a rule, the shortest separation "X" between the screening shields of the inserted Ethernet cables is crucial.

If it is intended that two or more EN-76 Network Isolators are to be installed side by side into a multiple module carrier, the mounting clearance must be taken into account. Crucial to this is the creepage distance between the screening shields of the patch cables inserted into neighbouring Network Isolators. The resulting creepage distance must not fall short of 8 mm in 250 V AC environments, and not less than 12 mm in 400 V AC environments.

Combining EN-76 Network Isolators and non-isolated modules within multiple module carriers is not recommended.



### 7.3 SAFETY NOTICE

During assembly, attention should be paid to ensure that the clearance and creepage distances required by IEC 60601-1 are met. The isolating effect of the Network Isolator must not be compromised by neighbouring conductive components. If, for example, the installation of the Network Isolator is to be within a metal plate, this plate must be connected to the ground potential (protective earth).

As a matter of principle, Network Isolators should be mounted as close as possible to the equipment requiring protection.

Damaged Network Isolators, and Network Isolators which are contaminated by dust or liquids, are to be replaced.

When used as directed, EMOSAFE Network Isolators are maintenance-free.

## 8 SPECIFICATIONS

### 8.1 GENERAL

Category	Standards or Test Criteria	Properties
Designation		EMOSAFE EN-76
Housing colour		EN-76xE-x: White EN-76HE: White and Black
Housing Material		Plastic
Construction		EN-76xE-K: Keystone-Modul EN-76xE-S: SnapFit-Modul EN-76HE: Standalone
Input Interface		RJ45 Jack, straight
Output Interface		EN-76HE-x: RJ45 Jack, straight EN-76VE-x: RJ45 Jack, angled
Weight		approximately 12 g
Protection rating	EN 60529	IP40
Mating cycles:	Correct: RJ45 plug in RJ45 socket	> 1000 cycles
	Mismatched: with RJ11 / RJ12 / RJ25	maximum of 100 cycles
Mean Time To Failure (MTTF)	SN 29500 Standard Temperature: 25°C Duty cycle: 100% (24 hours, 7 days)	3260 years
	SN 29500 Standard Temperature: 40°C Duty cycle: 100% (24 hours, 7 days)	3090 years

### 8.2 ETHERNET PERFORMANCE

Category	Standards or Test Criteria	Properties
Transmission Speeds and Supported Network Protocols	IEEE 802.3	100BASE-TX      bis 100 MHz*
		1000BASE-T      bis 100 MHz*
		2.5GBASE-T      bis 100 MHz*
		5GBASE-T      bis 250 MHz*
		10GBASE-T      bis 500 MHz*
	ISO/IEC 11801	Class D (CH & PL)      bis 100 MHz*
Class E (CH & PL)      bis 250 MHz*		
Class Ea (CH)      bis 500 MHz*		
TIA/EIA-568	Cat 5e (CH & PL)      bis 100 MHz*	
	Cat 6 (CH & PL)      bis 250 MHz*	
	Cat 6A (CH)      bis 500 MHz*	

\* maximum bandwidth frequency

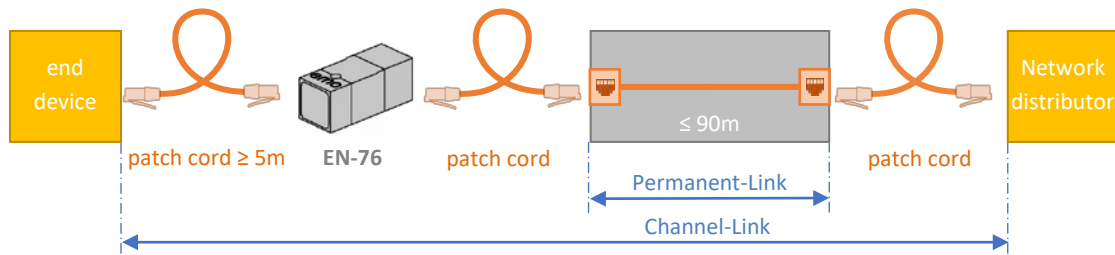

Figure 8 Recommended setup of the network isolator

The speed is classified, among other things, by adhering to limit values for the Insertion Loss (IL), the Return Loss (RL) and Near-End-Crosstalk (NEXT) of the system setup.

Figure 9 and Figure 10 show the IL of the network isolator without the remaining Channel-Link components. Figure 11 and Figure 12 show the RL and the NEXT performance of the recommended structure on the end device side. The RL and the NEXT depend strongly on the structure of the system and do not behave additively with the rest of the structure.

More detailed information on system setup, classifications, performance and the basics of the individual parameters can be found in our white paper "[Ethernet Performance of Network Isolators](#)".

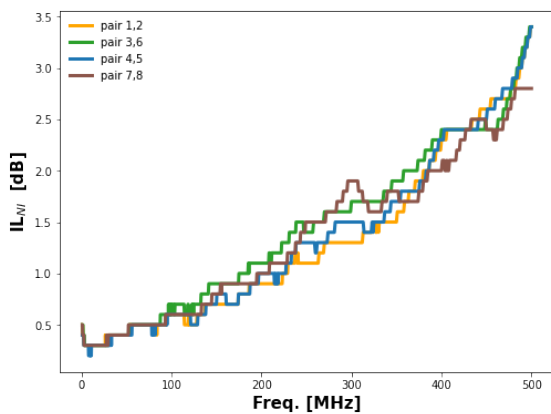

Figure 9 Insertion Loss of an EN-76

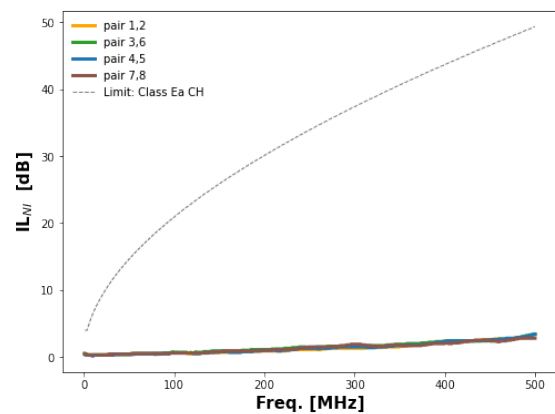

Figure 10 Insertion Loss of an EN-76 with the Class E<sub>A</sub> Channel-Link Limit

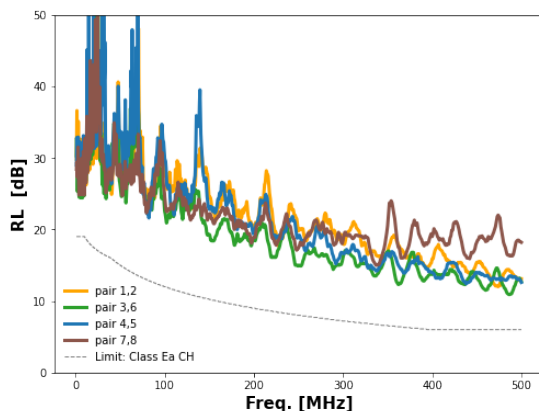

Figure 11 Return Loss of an EN-76 on the end device side of the setup of the recommended setup

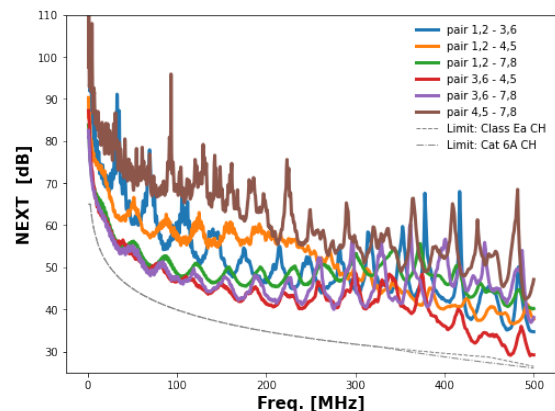

Figure 12 NEXT-Performance Loss of an EN-76 on the end device side of the setup of the recommended setup

### 8.3 ELECTRICAL

Category	Standards or Test Criteria		Properties
AC Dielectric Strength	at 50 Hz, for 60 seconds		6 kV
DC Dielectric Strength	for 60 seconds		8.5 kV
Reinforced Isolation	IEC 60601-1		✓
Coupling Capacitance / Channel			15 pF ±25%
Total Coupling Capacitance			60 pF ±25%
Total Leakage Current	275 V AC at 50 Hz	Typical:	12 µA
		Max.:	16 µA
TVS diode circuitry	Suppression of transients on the signal lines		✓

### 8.4 OPERATING CONDITIONS AND AREA OF APPLICATION

Category	Standards or Test Criteria		Properties
Pollution Degree	IEC 61010		2 <sup>1</sup>
Overvoltage Category	IEC 60664-1		III
Maximum Working Voltage <sup>2</sup>	Maximum mains voltage of the connected devices, in accordance with IEC 60601-1		400 V AC 450 V DC
Temperature		Min.:	-10°C
		Max.:	+70°C
Air Humidity	Non-condensing	Min.:	10%
		Max.:	90%
Air Pressure		Min.:	700 hPa
		Max.:	1060 hPa
Altitude	Max.:		3200 m

<sup>1</sup> Normally only nonconductive pollution occurs. Temporary conductivity caused by condensation is to be expected

<sup>2</sup> The Network Isolator can be permanently exposed to this voltage level.

### 8.5 ENVIRONMENTAL CONDITIONS: STORAGE AND TRANSPORTATION

Category	Standards or Test Criteria		Properties
Temperature		Min.:	-40°C
		Max.:	+70°C
Air Humidity	Non-condensing	Min.:	10%
		Max.:	90%
Air Pressure		Min.:	500 hPa
		Max.:	1060 hPa

## 8.6 CERTIFICATES

Category	Properties
UL Recognized Component	✓
UL File No.	E362969
IEC 60601-1	✓
IEC 60601-1-2	✓
ANSI/AAMI ES 60601-1	✓
CAN/CSA-C22.2 No. 60601-1	✓
Low Voltage Directive	✓
EMC Directive	✓
RoHS Directive	✓
Lead-free	✓

The versions of the cited standards and directives to which our products comply with can be found in our Declaration of Conformity and our UL certificate on our website under "[Standard Conformity and Certificates](#)".

## 9 SCHEMATIC DIAGRAM

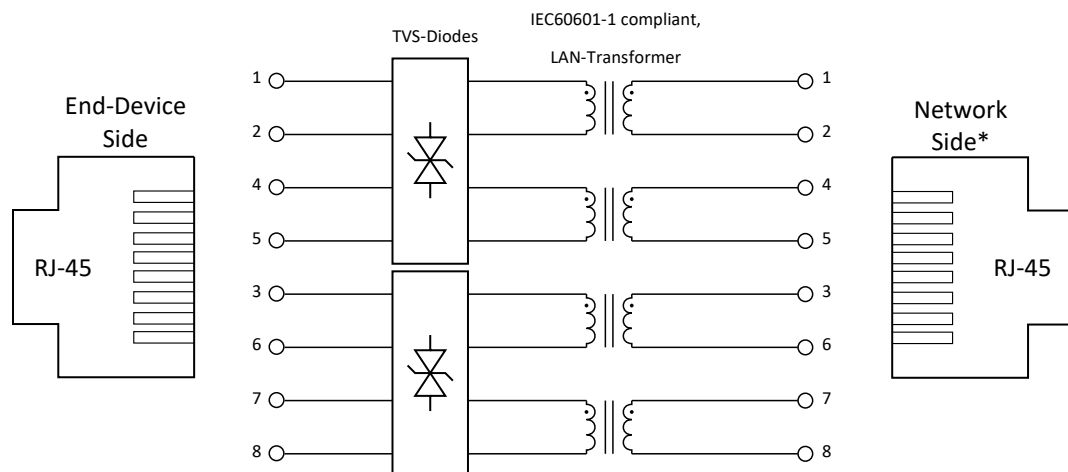

Figure 13 Circuit diagram for all EN-76 variants. \*The Network side is defined in the variants by the Keystone Modul, the Snap-Fit attachment or the black cap.

## 10 PACKAGING

Contents:





- Network Isolator EN-76
- Installation Guide

A packaging label provides the following information:

- Article description
- Quantity
- Date of Manufacture
- Serial number

The serial number is printed as both a 1D- (Code 128) and a 2D barcode (Data Matrix).

## 11 PRODUCT MARKINGS

	<p>Through this mark, the conformity of the product with all applicable EU Directives is confirmed.</p>
	<p>Designates the product as a UL "Recognised Component"; File No. E362969.</p>
	<p>The product may not be disposed of in domestic rubbish.</p>
	<p>This product meets the requirements of EU Directive concerning the limitation of the use of certain hazardous substances in electric and electronic equipment.</p>

## 12 ENVIRONMENTAL PROTECTION INFORMATION

This device contains electronic components. At the end of its service life it is to be returned to the manufacturer for disposal.

## 13 QUALITY

EMO Systems operates a certified quality management system for development and production in accordance with ISO 9001 and ISO 13485. Prior to delivery, each Network Isolator is subjected to a comprehensive quality inspection. This inspection ensures, among other factors, that the attained values for leakage currents, dielectric withstand strengths, insertion losses, return losses, and near end crosstalk values all meet the specified requirements.

## 14 CONTACT AND SUPPORT

---

Please find our up-to-date contact details on our website:

<https://emosystems.de/en/contact/>

Or send us an e-mail at the following address:

[support@emosystems.de](mailto:support@emosystems.de)

## 15 LEGAL NOTIFICATION

---

The information provided above in this datasheet has been compiled with all due care and is believed to be accurate and reliable. However, we cannot guarantee that the information contained is completely free from error.

The end user is responsible and liable for the proper use of this product; EMO Systems assume no liability. We reserve the right to make changes to this datasheet without notice.