



Model PFLOW3000 Series

MEMS Mass Flow Sensors

_____ (VB.0)

CE

MEMS Mass Flow Sensor

The PFLOW3000 series of mass flow sensors are made with the micromachined (MEMS) sensing elements that offer an innovative thermal sensing principle with excellent linearity and removal of gas sensitivity of some common gases.

This PFLOW3000 Series mass flow sensor series offer a fully customizable flow dynamic range of 100:1 with the full-scale flowrate from 2 SLPM to 50 SLPM.

The sensors are opted with digital (I²C or RS485) and analog interface, with an operational temperature range of -10 to 55 °C.



SPECIFICATIONS

Performance characteristics

(Test conditions: V_{cc} = 8 ~ 24 VDC, T_a = 20°C, RH_a = 30...70%)

Parameter	PFLOW3008			Unit
Flow range, full scale ⁽¹⁾	2, 3, 4, 5	10, 20	30, 40, 50	SLPM
Dynamic range	100:1			n.a.
Accuracy ⁽²⁾	± (1.5%RD + 0.2%FS)			%
Temperature error coefficient ⁽³⁾	0.1			%RD/°C
Maximum common mode pressure	117 (8)			psi (bar)
Maximum overflow	30	100	200	SLPM
Maximum flowrate change	4	15	30	SLPM/sec
Compensated temperature range	0 ~ 60			°C
Operating temperature range	-10 ~ 55			°C
Storage temperature	-20 ~ 70			°C
Humidity	0 ~ 95 (no condensation)			%RH
Gas compatibility	Non-corrosive/non-explosive			
Shock	100 (MIL-STD-883)			g
Compliance	RoHS, REACH, CE: IEC 61000-4-2;4;8			
Wetted materials	Polycarbonate, ABS, silicon nitride, FR4 and epoxy			

Electrical Characteristics

(Test conditions: Vcc = 8-15VDC, Ta = 20°C, RHa = 30...70%)

Item	Condition	Rating			Unit
		Min.	Typ.	Max.	
Supply voltage		8		24	VDC
Supply current		10	15	50	mA
Warmup time ⁽⁴⁾			500		msec
Minimum Output load (analog & digital version)			5		kΩ
Response time (digital, analog)			10		msec
Output (analog) ⁽⁵⁾		0.5		4.5	VDC
Analog null voltage		0.47		0.53	VDC
Analog null drift			0.05		%FSS/year
Maximum output ⁽⁶⁾				1.1	FS
Output (digital)			I ² C, RS485		--
I2C bus voltage		3.0		5.5	VDC
I2C frequency		10		400	kHz
Resolution digital output			15		bit
Digital null offset			0		
Digital null drift ⁽⁷⁾				0.05	%FSS/year

Note:

1. SLPM denotes standard cubic centimeters per minute.
Standard conditions: 20°C, 101.325kPa, dry and clean air.
2. Accuracy is the combined error from offset and span calibration, linearity, hysteresis, and repeatability over the entire calibrated flow range.
3. For compensated temperature range.
4. Warm-up time is the time from power on to the first stable reading.
5. Output not ratio metric.
6. Refer to Typical Output chapter for details.
7. Digital offset can be reset using I²C or RS485 command.

PRESSURE DROP CHARACTERISTICS

The product is designed for low-pressure loss. The major drop in the pressure is at the manual valve structure. The following graph illustrated the pressure losses of the selected models.

Table 1: PFLOW3008-2/3/4/5SLPM pressure loss

Flow rate (SLPM)	Pressure loss (Pa)			
	R 1/4	8mm	6mm	4mm
0.0	0	0	0	0
1.0	10	15	20	30
2.0	25	30	40	80
3.0	40	50	60	150
4.0	60	70	90	240
5.0	80	100	130	370

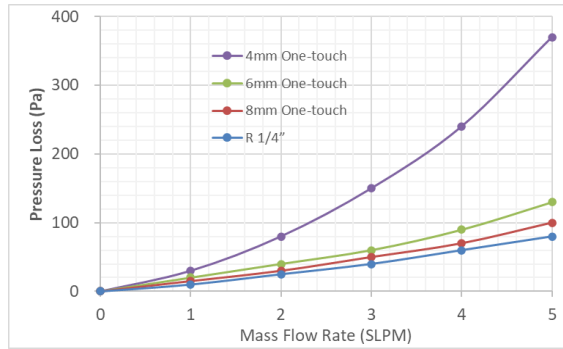

Figure 1: PFLOW3008-2/3/4/5SLPM pressure loss

Table 2: PFLOW3008-10/20SLPM pressure loss

Flow rate (SLPM)	Pressure loss (Pa)			
	R 1/4	8mm	6mm	4mm
0.0	0	0	0	0
5.0	50	60	80	130
10.0	150	170	250	450
15.0	300	350	500	850
20.0	500	600	800	1400

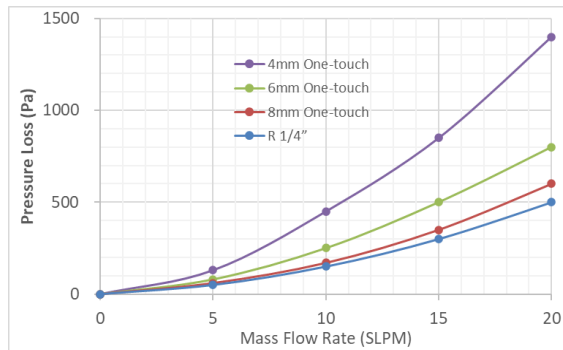

Figure 2: PFLOW3008-10/20SLPM pressure loss

Table 3: PFLOW3008-30/40/50SLPM pressure loss

Flow rate (SLPM)	Pressure loss (Pa)			
	R 1/4	8mm	6mm	4mm
0.0	0	0	0	0
10.0	150	180	250	450
20.0	400	450	750	1500
30.0	900	1000	1600	3000
40.0	1500	1700	2600	4800
50.0	2200	2500	4000	7000

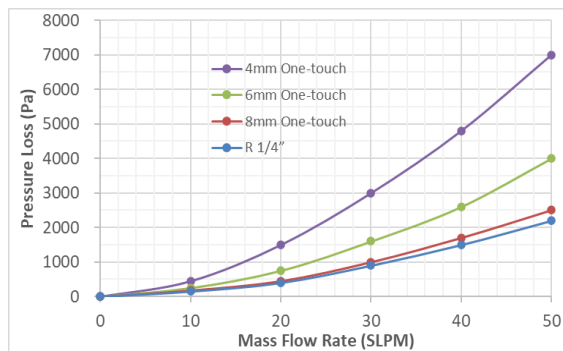

Figure 3: PFLOW3008-30/40/50 pressure loss

MECHANICAL DIMENSIONS

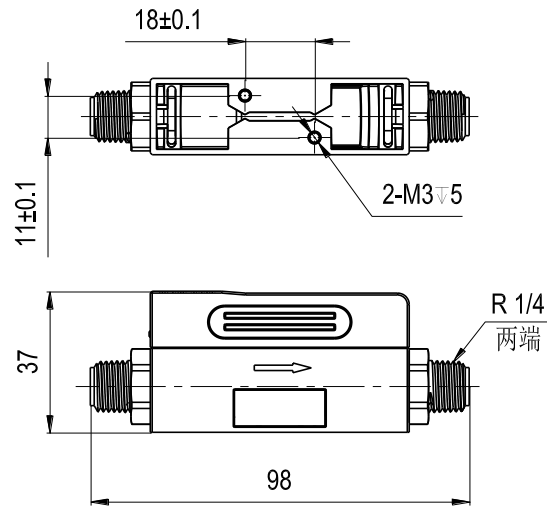

Figure 4: PFLOW3000 dimensions with BSPT (R1/4") connectors. All units are in mm

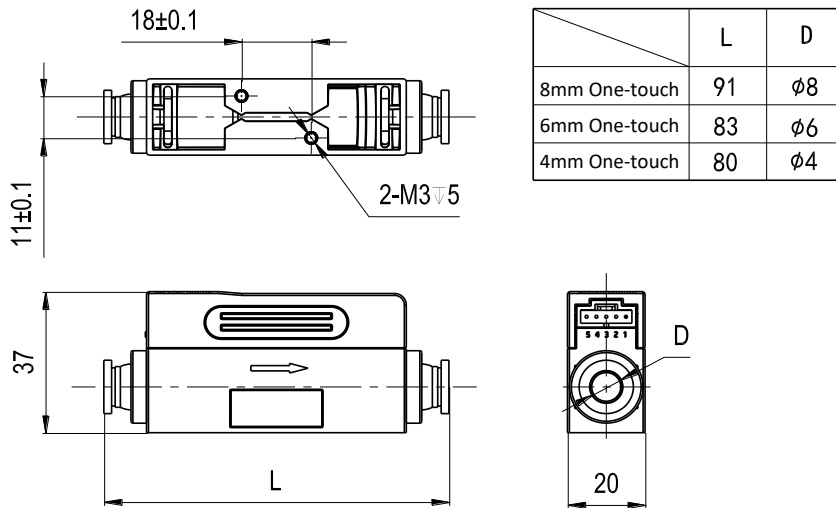

Figure 5: PFLOW3000 dimensions with one-touch connectors. All units are in mm

ELECTRICAL INTERFACE

Pin#	Color	Definition	Notes
1	Blue	SDA RS485 B (-)	I ² C data
2	Green	Vcc	Power supply, 8~24Vdc
3	Red	Vout	Output ref. to GND
4	Black	Vss	GND
5	Yellow	SCL RS485A (+)	I ² C clock

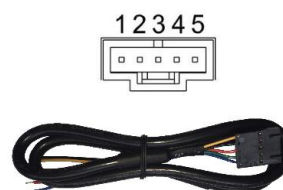

Figure 6: PFLOW3000 connection and cable

GAS CORRECTION FACTORS

Gas type	Correction factor
Air	1.0
Oxygen (O ₂)	1.0
Nitrogen (N ₂)	1.0
Argon (Ar)	1.0
Carbon dioxide (CO ₂)	0.545

To obtain the real flow rates in a specific gas, multiply the readings from the sensor by the gas correction factor in the table. The factors are approximate and should be used as guidelines only. Sensor performance strongly depends on gas dynamics and has to be evaluated in the respective application.

TYPICAL OUTPUT (ANALOG OUTPUT)

Analog Output

Table 3: PFLOW3000 typical analog output

Flow rate (SLPM)	Typical Analog output (Vdc)
0	0.5
0.2FS	1.3
0.4FS	2.1
0.6FS	2.9
0.8FS	3.7
1.0FS	4.5
1.1FS	4.9
1.2FS	4.9

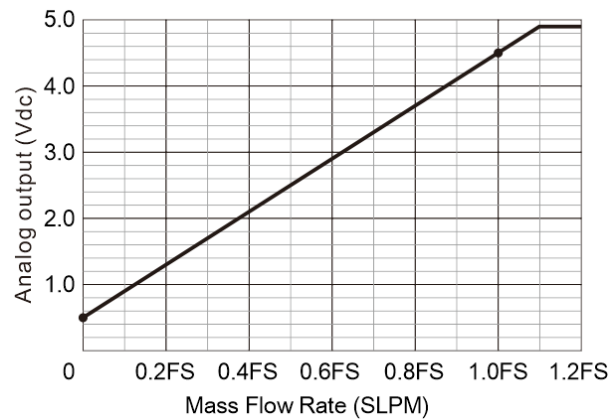

Figure 7: PFLOW3000 typical analog output

Digital Output

Table 4: PFLOW3000 typical digital output

Flow rate (SLPM)	Typical Digital output (SLPM)
0	0
0.2FS	0.2FS
0.4FS	0.4FS
0.6FS	0.6FS
0.8FS	0.8FS
1.0FS	1.0FS
1.1FS	1.1FS
1.2FS	1.1FS

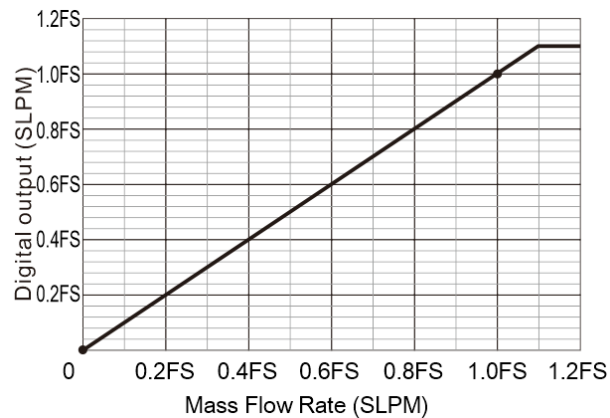

Figure 8: PFLOW3000 typical digital output

DIGITAL RS485 Modbus COMMUNICATION

The digital communication protocol is based on standard Modbus RTU Half-plex mode. A master (PC or PLC) can communicate with multiple slaves (the current product) for data exchange and communication parameter configuration. Refer to ELECTRICAL INTERFACE for cable connection.

Hardware connection

The RS485 hardware layer is TIA/EIA-485-A, as illustrated below. In this configuration, the product (PFLOW3000) is a slave.

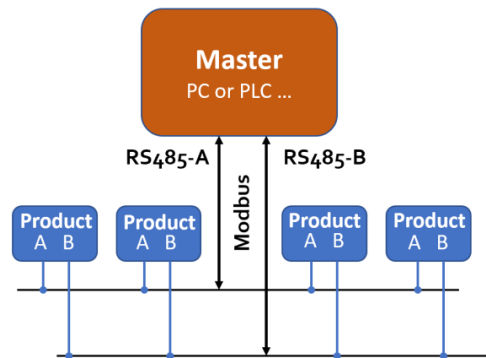

Communication parameters

The PC UART communication parameters are listed in the following table.

Parameters	Protocol
	RTU
Baud rate (Bits per second)	38400 bps
Start bits	1
Data bits	8
Stop bits	1
Even/Odd parity	None
Bits period	104.2 μ sec
Bytes period	1.1458 msec
Maximum data length	20
Maximum nodes	247

Frame

The frame function is based on the standard Modbus RTU framing:

Start_bits	Address	Function codes	Data	CRC	Stop_bits
T ₁ -T ₂ -T ₃ -T ₄	8 bit	8 bit	N 8 bit (20≥n≥0)	16 bit	T ₁ -T ₂ -T ₃ -T ₄

Start_bits: 4 periods bit time, for a new frame.

Address: The address can be set from 1 to 247 except for 157 (0x9d). 0 is the broadcast address.

Function codes: Define the product's functions/actions (slaves), either execution or response.

Data: The address of the register, length of data, and the data themselves.

CRC: CRC verification code. The low byte is followed by the high byte. For example, a 16-bit CRC is divided into BYTE_H and BYTE_L. In the framing, the BYTE_L will come first, then followed by the BYTE_H. The last one is the STOP signal.

Stop_bits: 4 periods bit time, for ending the current frame.

Function codes

The Modbus function codes applied for the product are the sub-class of the standard Modbus function codes. These codes are used to set or read the registers of the product:

Code	Name	Functions
0x03	Read register	Read register(s)
0x06	Set single register	Write one single 16-bit register
0x10	Set multiple registers	Write multiple registers

Registers

The product (PFLOW3000) has multiple registers available for the assignment of the various functions. With these functions, the user can obtain the data from the products, such as product address and flow rates from the registers, or set the product functions by writing the corresponding parameters.

The currently available registers are listed in the following table, and the registers may be customized upon contacting the manufacturer. Where R: read; W: write-only; W/R: read and write.

Note: At the time of shipping, the write protection function is enabled except for address and baud rate. Once the user completes the register value change, the write protection will be automatically enabled once again to prevent incidental data loss.

Functions	Description	Register	Modbus
Address	Product address (R/W)	0x0081	40130 (0x0081)
Serial number	Serial number of the product (R)	0x0030 ~ 0x0035	40049 (0x0030)
Flow rate	Current flow rate (R)	0x003A ~ 0x003B	40059 (0x003A)
Baud rate	Communication baud rate (R/W)	0x0082	40131 (0x0082)
GCF	Gas conversion factor (R/W)	0x008B	40140 (0x008B)
Digital filter depth	Response time or sampling time (R/W)	0x008C	40141 (0x008C)
Offset calibration	Offset reset or calibration (W)	0x00F0	40241 (0x00F0)
Write protection	Write protection of selected parameters (W)	0x00FF	40256 (0x00FF)

The detailed information of each register is described below: Y: enabled; N: disabled

Address	0x0081	Write	Y
		Read	Y
Description	Address of the product		
Value type	UINT 16		
Notes	Values from 1 to 247 except for 157 (0x9d). The broadcast address is not enabled, and the default address is 1.		

SN, Serial number	0x0030 ~ 0x0035	Write	N
		Read	Y
Description	Series Number of the product, SN		
Value type	ASCII		
Notes	SN= value(0x0030), value(0x0031),...,value (0x0035); Receiving 12 bits as: 2A 41 31 42 32 33 34 35 36 2A, the corresponding Serial Number is **A1B23456**.		

Flow rate	0x003A ~ 0x003B	Write	N
		Read	Y
Description	Current flow rate		
Value type	UINT 16		
Notes	Flow rate = [Value (0x003A) * 65536 + value (0x003B)] / 1000 e.g.: When the user reads "0" from register 0x003A and "20340" from register 0x003B, current flow rate = (0 * 65536 + 20340) / 1000 = 20.340 SLPM		

Baud rate	0x0082	Write	Y
		Read	Y
Description	Communication baud rate		
Value type	UINT 16		
Notes	0: baud rate=4800; 1: baud rate=9600; 2: baud rate=19200; 3: baud rate=38400. The default value is 3. e.g.: When the user reads "3" from register 0x0082, the baud rate is 38400.		

GCF	0x008B	Write	Y
		Read	Y
Description	The gas conversion factor for applicable gas is different from calibration gas		
Value type	UINT 16		
Notes	The GCF of air is 1000 (default), normally read from register 0x008B. Note: The product will disable this function with write protection once the metering gas is confirmed with the proper GCF. For a specific GCF value, please contact the manufacturer.		

Response time	0x008C	Write	Y
		Read	Y
Description	Digital filter depth setting		
Value type	UINT 16		
Notes	0 ~ 9 programmable, corresponding to $2^0 \sim 2^9$ data sampling in the software filter. The default value is 3, corresponding to $2^3 = 8$ data sampling.		

Offset calibration	0x00Fo	Write	Y
		Read	N
Description	Reset or calibrate the offset		
Value type	UINT 16, Fixed value 0xAA55		
Notes	To reset or calibrate the offset, write 0xAA55 to register 0x00Fo. Note: When you execute this function, make sure there is NO flow in the flow channel.		

Write protection	0x00FF	Write	Y
		Read	N
Description	Write protection disabler for a set value to a specific register.		
Value type	UINT 16, Fixed value 0xAA55		
Notes	This function is enabled at the time of product shipment. To enable the write function of a specific parameter, such as GCF, or offset, the user needs to send 0xAA55 to the register 0x00FF, and then the write function will be enabled (write protection is disabled). After the write execution is completed, the firmware will automatically re-enable the write protection.		

DIGITAL I²C COMMUNICATION

I²C interface connection diagram

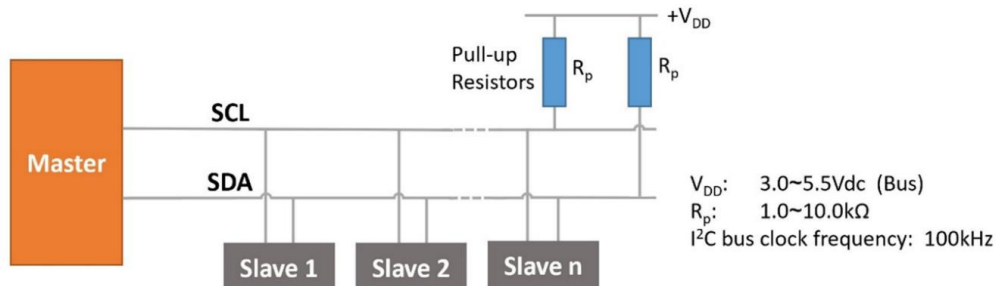

I²C interface command description

Command	Width (Byte)	Command Name	Read/Write	Notes
0x00A4	1	I ² C address	Read/Write	Int 16. bit 0 is the R/W flag bit; bit 1 ~ bit 7 are available; bit 8 ~ bit 15 = 0. The default I ² C address is 1. Hex: 0x0002 (write) /0x0003 (read), Bin: 0000 0000 0000 0010 (write) 0000 0000 0000 0011 (read).
0x0030	6	Sensor serial number	Read	ASCII
0x003A	2	Flow rate	Read	Int 32/1000 SLPM
0x008B	1	Gas correction factor (GCF)	Read/Write	The gas conversion factor for applicable gas is different from calibration gas.
0x008C	1	Filter depth	Read/Write	Int 16, 0 ~ 9, corresponding to 2 ⁰ ~ 2 ⁹ data in the software filter. The default value is 3, corresponding to 2 ³ = 8 data in the software filter
0x00F0	1	Reset the offset of differential pressure	Write	Fixed value, 0xAA55

Notes:

- 1, I²C is an onboard protocol. It is not intended for usage with cables. If the sensor is used connected via cables, it is recommended to check the system carefully for electromagnetic disturbances.
- 2, The I²C address is set to Bit 7 ~ Bit 1.
e.g., if the I²C address is 1 (0000 001x), the write address will be 0x02 (0000 0010) and the read address will be 0x03 (0000 0011).
- 3, The highest significant byte is transmitted first; the lowest significant byte is transmitted last.

CRC checksum calculation

The 8-bit CRC checksum transmitted after each two data bytes (int 16) is generated by a CRC algorithm. Its properties are listed in the following table. To calculate the checksum, only these two previously transmitted data bytes are used.

Property	Value
Name	CRC-8
Protected data	I ² C read and write
Width	8 bits
Polynomial	0x07 (x ⁸ + x ² + x + 1)
Initialization	0x00
Reflect input	False
Reflect output	False
Final XOR	0x00
Example	CRC (0x4E20) = 0x6D

I²C interface read/write sequences

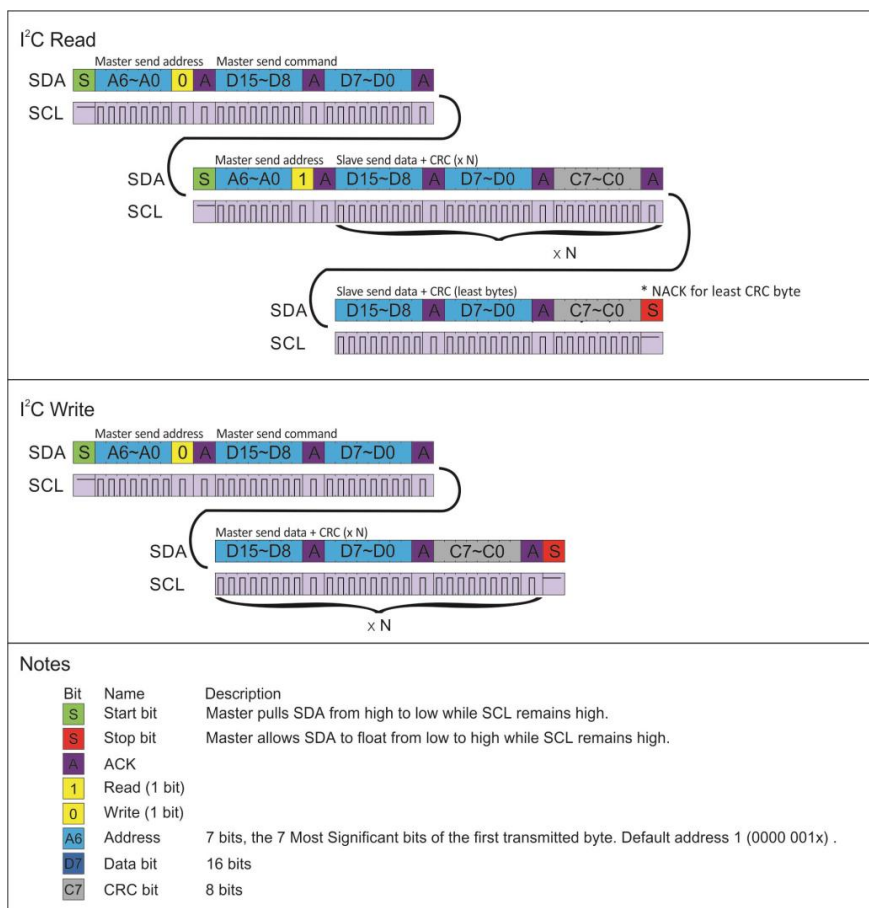

ORDERING INFORMATION

The product part number is composed of the product model number and suffix indicating the full-scale flow rate, mechanical connection, output format as well as the applicable gas. Refer to the following for the product order:

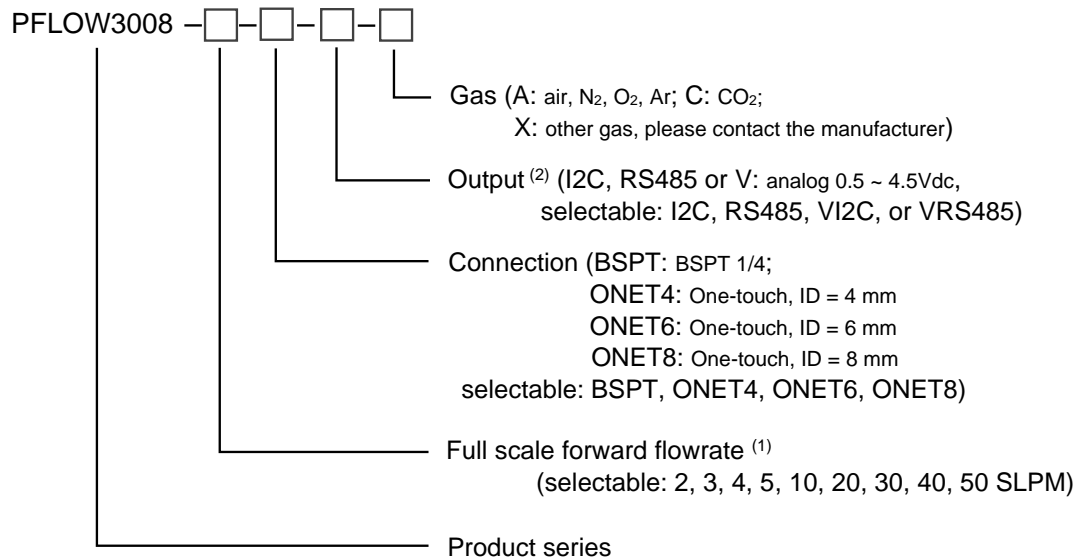

Note:

(1) Full flowrate default unit is SLPM

(2) VI2C model consist of both outputs digital I2C and analog 0.5 ~ 4.5 Vdc, VRS485 model consist of both outputs digital RS485 and analog 0.5 ~ 4.5 Vdc.

WARRANTY AND LIABILITY

CUSTOMER SERVICES

DRAFT VERSION CONTROL

Revision VB.o (January 2024)

- Change to base model 34300.
- Models: Remove PFLOW3003.
- Flow range: PFLOW3008 has 3 different flow conditioners.
 - ◆ Full scale 2, 3, 4, 5 SLPM;
 - ◆ Full scale 10, 20 SLPM;
 - ◆ Full scale 30, 40, 50 SLPM.
- Maximum common mode pressure: 117 psi / 8bar (before 75 psi / 5 bar).
- Mechanical dimensions, Height change from 35 mm to 37 mm, other dimensions are same.
- Connection: BSPT, ONET₄, ONET₆, ONET₈ can be selected for all flow rates;
- Higher pressure drop.

Revision VA.o (October 2022)

- First release of base model 34100.

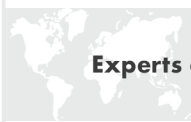

We are here for you. Addresses and Contacts.

Headquarter Switzerland:

Angst+Pfister Sensors and Power AG
Thurgauerstrasse 66
CH-8050 Zurich
Phone +41 44 877 35 00
sensorsandpower@angst-pfister.com

Office Germany:

Angst+Pfister Sensors and Power Deutschland GmbH
Edisonstraße 16
D-85716 Unterschleißheim
Phone +49 89 374 288 87 00
sensorsandpower.de@angst-pfister.com

Scan here and get an overview of personal contacts!



sensorsandpower.angst-pfister.com
