

公差/General tolerances (mm)											D 0.1/10		
0	>3	>6	>10	>18	>30	>50	>80	>120	>180	>250		>315	>400
~ 3	~ 6	~ 10	~ 18	~ 30	~ 50	~ 80	~ 120	~ 180	~ 250	~ 315	~ 400	~ 500	~ >500
±0.12	±0.18	±0.22	±0.26	±0.31	±0.37	±0.57	±0.80	±0.93	±1.05	±1.15	±1.60	±2.20	±2.50

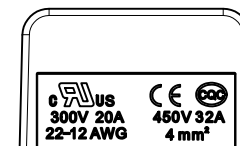
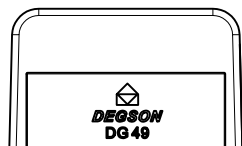
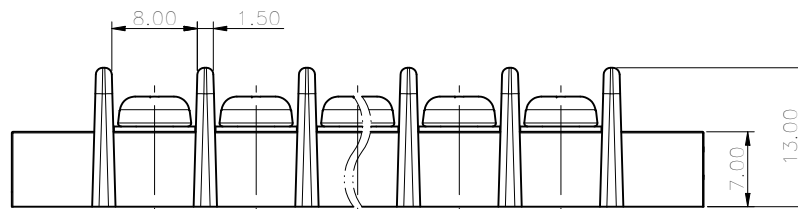
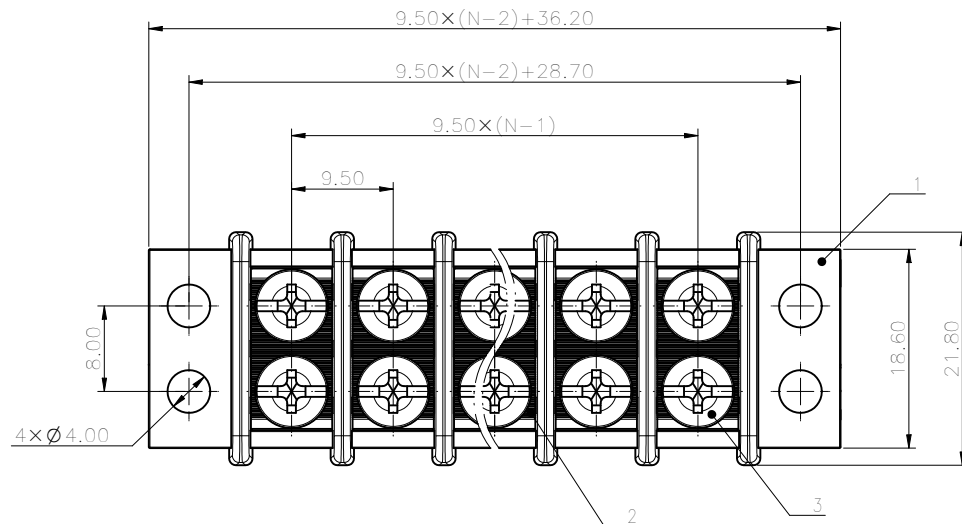

3	Screw	Steel	Ni Plated
2	Clamp	Copper alloy	Sn Plated
1	Housing	PC	UL94V-2
ITEM	NAME OF PART	MATERIAL	NOTES

UL 标准/UL Standard:		B	C	D
额定电压/电流/Rated Voltage(V)/Current(A)		300/20	/	/
IEC 标准/IEC Standard:				
额定电压/电流/Rated Voltage(V)/Current(A)		450/32		
螺丝扭矩/Torque Tightening(N·m/Lb.in)		M3.5 0.8/7.08		
线径范围(硬线和软线)/Wire Range(rigid and flexible)(AWG/mm²)		22-12 / 4.0		
间距/Pitch(mm)/线数范围/Poles		9.50/N=02-24P		
剥线长度/Stripping length(mm)		7-8		
使用温度范围/Operating temperature(°C)		-40~+80		
符合RoHS环保要求/Conform to RoHS		Yes		

DEGSON MATERIAL: SURFACE/COLOR: MAT NO./REV: - / 00 MAT STATUS: 批量

APPD: 蓝美凡 2023.02.20 NAME: DG49-A-XXP-1Y-00L(H)

CHKD: 曹利彬 2023.02.20

DRAFT: 姜民浩 2023.02.20

REV	ECN	DESCRIPTION	DRAFT	DATE	DRAWING NO.	TYPE	DRAWING STATUS	SCALE	SHEET
00					200071909	CUSTOMER DRAWING	已发布	2:1	1/1

REV	ECN	DESCRIPTION	DRAFT	DATE
00				

Transfer or duplication of this document as well as the utilization or reproduction of its contents without the written consent of the copyright holder is prohibited. All rights reserved for patent. 本文件及其中所载之技术内容，未经许可，不得复制或传播。如有侵权，本公司保留追究法律责任之权利。