

Transfer or duplication of this document as well as the utilization or communication of its contents are prohibited unless authorized in writing by DEGSON. All rights reserved for patent, utility model or design registrations. 除专利、实用新型、外观设计、发明专利等知识产权外，其他权利均归 DEGSON 所有。未经许可，不得复制或传播本文件内容。

未注公差/General tolerances (mm)												0.1/10 ±2'		
0 ~ 3	>3 ~ 6	>6 ~ 10	>10 ~ 18	>18 ~ 30	>30 ~ 50	>50 ~ 80	>80 ~ 120	>120 ~ 180	>180 ~ 250	>250 ~ 315	>315 ~ 400		>400 ~ 500	>500
±0.12	±0.18	±0.22	±0.26	±0.31	±0.37	±0.57	±0.80	±0.93	±1.05	±1.15	±1.60	±2.20	±2.50	

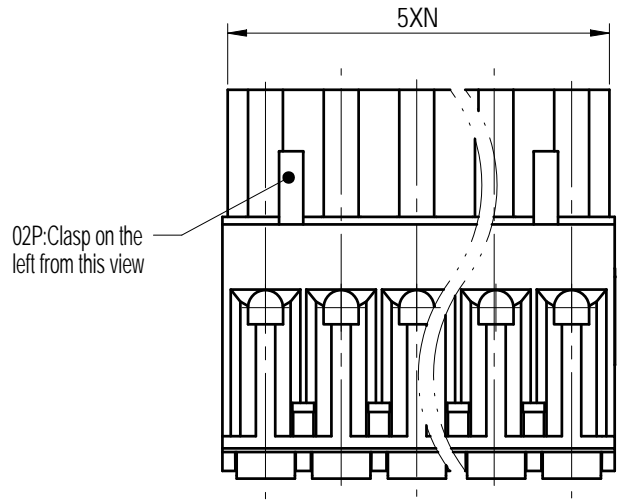

Please refer to the 3D model for those unmarked dimensions

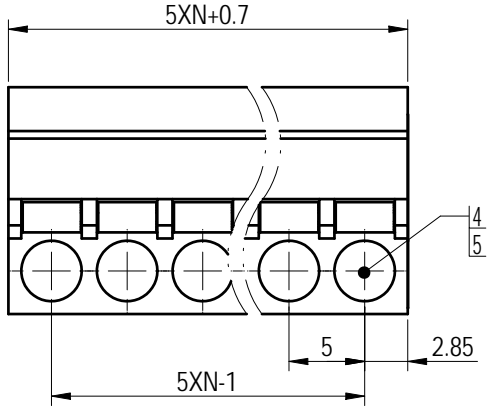
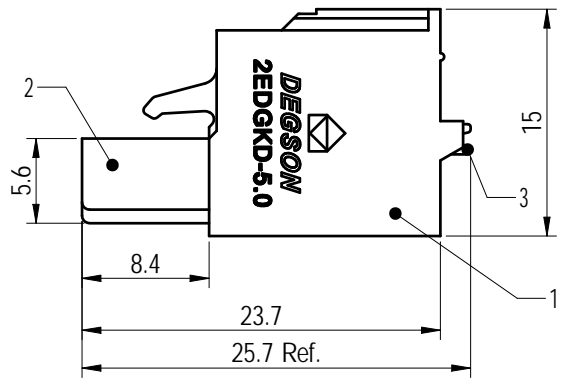
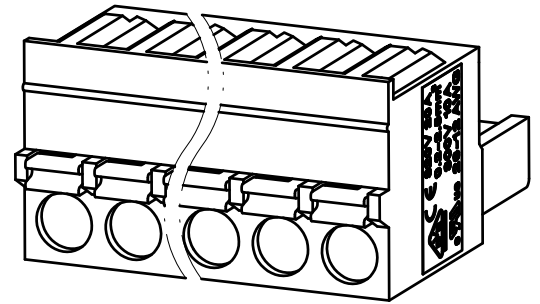

ITEM	NAME OF PART	MATERIAL	NOTES
5	Spring	Stainless steel	/
4	Clamp	Copper Alloy	Sn Plated
3	Button	PA66	UL94V-0
2	Cover	PA66	UL94V-0
1	Housing	PA66	UL94V-0

UL 标准/UL Standard:	B	C	D
额定电压/电流/Rated Voltage(V)/Current(A)	300/10	/	300/10
IEC 标准/IEC Standard:			
过压类别/Overvoltage Category/污染等级/Pollution Degree	III/3	III/2	II/2
额定电压/电流/Rated Voltage(V)/Current(A)	/	320/20	/
额定脉冲电压(KV)/Rate Impulse Voltage(KV)	/	4	/
线径范围(硬线和软线)/Wire Range(rigid and flexible)(AWG/mm²)	26~12 / 0.2~2.5		
间距/Pitch(mm)/线数范围/Poles	5.0/N=02~24P		
剥线长度/Stripping length(mm)	9~10		
使用温度范围/Operating temperature(°C)	-40~+105		
符合RoHS环保要求/Conform to RoHS	Yes		
标准颜色编号/Standard color number: PANTONE / RAL	/		

DEGSON

APPD: 兰春华 2022.08.08
 CHKD: 龚耀志 2022.08.08
 DRFT: 方哲盛 2022.08.05

MATERIAL:	SURFACE/COLOR:		
MAT NO./REV:	/ 00	MAT STATUS: 批量	
NAME			
2EDGKD-5.0-XXP-1Y-00L(H)			
DRAWING NO.	TYPE	DRAWING STATUS	SCALE
200019062	CUSTOMER DRAWING	已发布	2:1
SHEET			1/1

REV	ECN	DESCRIPTION	DRFT	DATE
00			方哲盛	2022.08.05