

未注公差/General tolerances (mm)													0.1/10 ±2'	
0	>3	>6	>10	>18	>30	>50	>80	>120	>180	>250	>315	>400		>500
±0.12	±0.18	±0.22	±0.26	±0.31	±0.37	±0.57	±0.80	±0.93	±1.05	±1.15	±1.60	±2.20	±2.50	

with the salients for 2-6P
without them for 7-24P

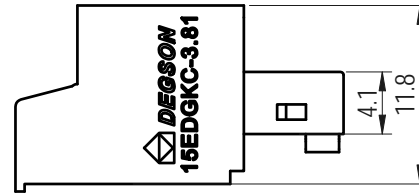
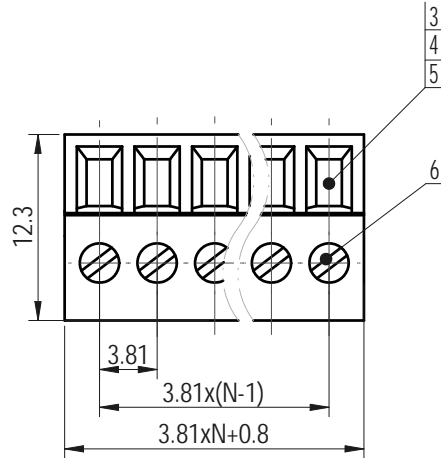
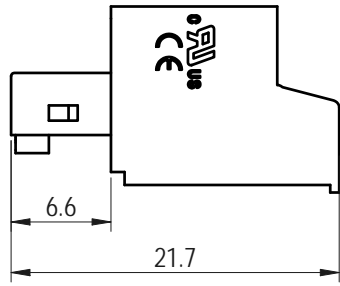
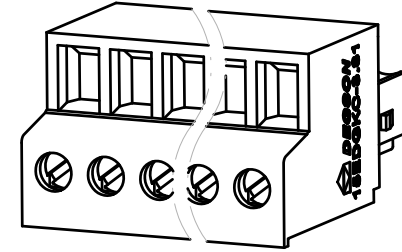
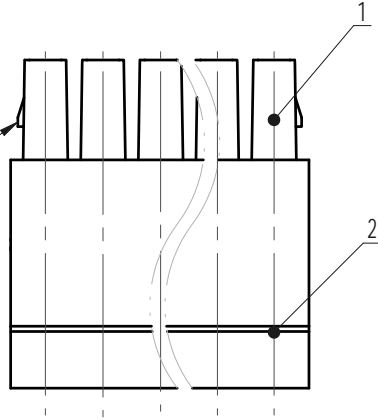

ITEM	NAME OF PART	MATERIAL	NOTES
6	Screw	Steel	M2/Zn Plated
5	Cage	Steel	M2/Zn Plated
4	Block	Steel	Zn Plated
3	Clamp	Copper alloy	Sn Plated
2	Housing	PA66	UL94V-0
1	Cover	PA66	UL94V-0

UL 标准/UL Standard:	B	C	D
额定电压/电流/Rated Voltage(V)/Current(A)	300/8	/	/
IEC 标准/IEC Standard:			
过压类别/Overvoltage Category/污染等级/Pollution Degree	III/3	III/2	II/2
额定电压/电流/Rated Voltage(V)/Current(A)	/	160/8	/
额定脉冲电压(KV)/Rate Impulse Voltage(KV)	/	2.5	/
螺丝扭矩/Torque Tightening(N·m/Lb.in)	M2, 0.2/1.77		
线径范围(硬线和软线)/Wire Range(rigid and flexible)(AWG/mm ²)	28~16 / 1.5		
间距/Pitch(mm)/线数范围/Poles	3.81/N=02~24P		
剥线长度/Stripping length(mm)	6~7		
使用温度范围/Operating temperature(°C)	-40~+105		
符合RoHS环保要求/Conform to RoHS	Yes		
标准颜色编号/Standard color number: PANTONE / RAL	/		



APPD: 兰春华	2022.08.23
CHKD: 龚耀志	2022.08.23
DRFT: 刘强	2022.08.23

MATERIAL:	SURFACE/COLOR:	
MAT NO./REV:	/ 00	MAT STATUS:
NAME		
15EDGKC-3.81-XXP-1Y-00L(H)		
DRAWING NO.	TYPE	DRAWING STATUS
200103325	CUSTOMER DRAWING	已发布
SCALE	SHEET	
2:1	1/1	

00			刘强	2022.08.23
REV	ECN	DESCRIPTION	DRFT	DATE

Transfer or duplication of this document as well as the utilization or communication of its contents are prohibited unless authorization is granted. Violations will be held for compensation. All rights reserved for patent, utility model or design registrations. 除专利权明确标注外, 未经许可, 不得复制或传播。 未经授权, 不得复制或传播。 侵权必究。