

E4-56  
H4-56  
R4-56



# e-chain system® E4-1

## Series E4-56/H4-56/R4-56

### Price Index



Series E4-56



Series H4-56



Series R4-56

### Special Options Available



Low noise version available with special rubber pads



Cleanroom test upon request



ESD classification: Electrically conductive ESD/ATEX version upon request

### Assembly Tips



Opening e-chains®: Remove crossbars and clips - Insert screwdriver into the slot, push down, release by lever action



Remove lids/bottoms (e-tubes) - Insert screwdriver into the slot, release by lever action

### Other Installation Methods

Vertical, hanging ≤ 328 ft (100 m)

Vertical, standing ≤ 19.69 ft (6 m)

Side-mounted, un\_supp. ≤ 8.20 ft (2.5 m)

Rotary requires further calculation

### Usage Guidelines



- If quiet operation is required
- If very high speeds and/or accelerations are required
- Long travels
- High additional loads



- When an extremely low vibration e-chain®/e-tube is required  
➤ Series E6-52
- When an economic one-sided snap-open e-chain®/e-tube is required  
➤ Series 14040/14140/R18840

### Features & Benefits

- 1 Wide, rounded plastic crossbars - cable friendly
- 2 Low-noise operation through integrated brake in the radial stop dog system
- 3 Hinged snap-open removable lids along the outer radius of the e-tube
- 4 Straight run through inner-/outer-link design
- 5 The tongue and groove design provides greater lateral stability
- 6 QuickLock Crossbar, 450-X-Q, available for faster assembly/disassembly
- 7 New Interior separation kit available
- 8 Crossbars are removable along both radii
- 9 15% more tensile strength (compared to the older E4 series), better unsupported length through improved stop dog system and vertical radial stops
- 10 Version NCST "without camber" simply by turning outer links without unnecessary rework

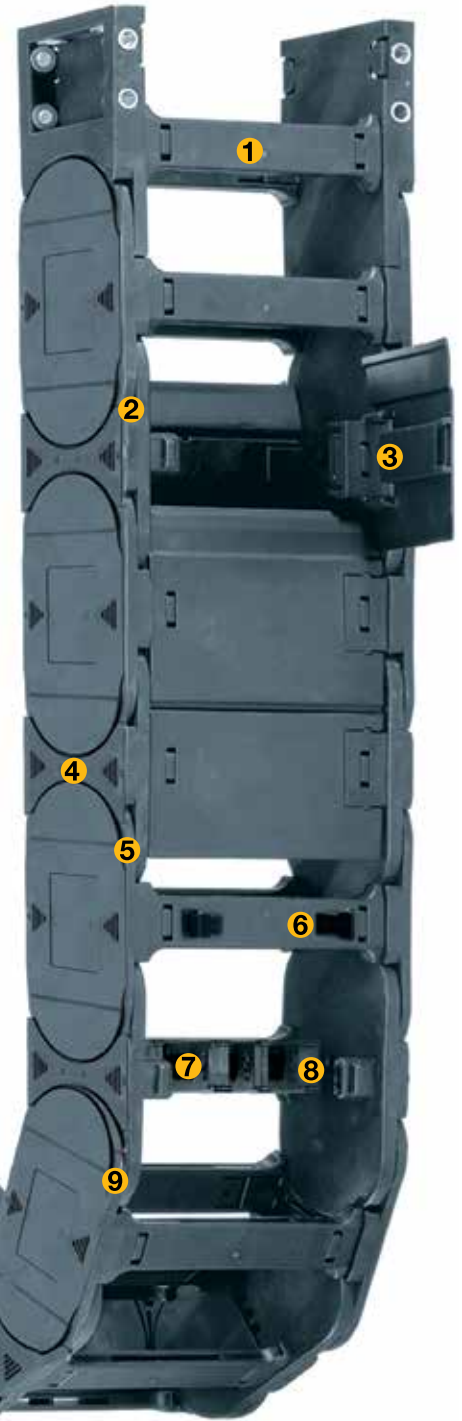

Also available without camber. Add NCST to the end of the part number.  
Ex: E4-56-30-300NCST

### Order Example: Complete e-chain®

Please indicate chain length or number of links. Example:

9.84 ft (3 m) E4-56-30-300-0



e-chain®

With 2 separators 56.1.1 assembled every 2nd link



Interior Separation

1 Set E4-560-30-12P



Mounting Bracket

# e-chain system® E4-1

## Series E4-56/H4-56/R4-56

### Installation Dimensions

Short travel, unsupported length

- $FL_B$  = unsupported with permitted sag
  - $FL_G$  = unsupported with straight upper run
- Further information ► Design, Chapter 1

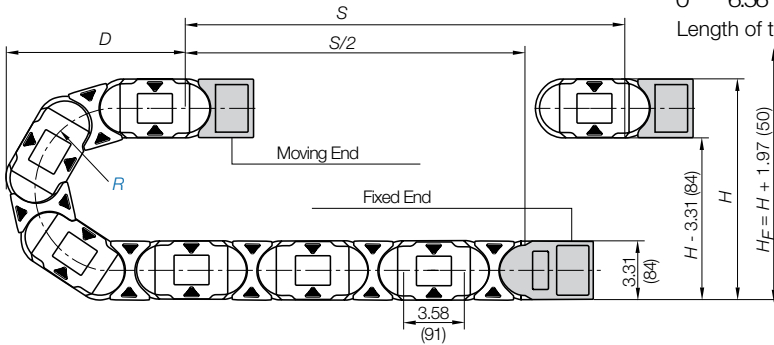
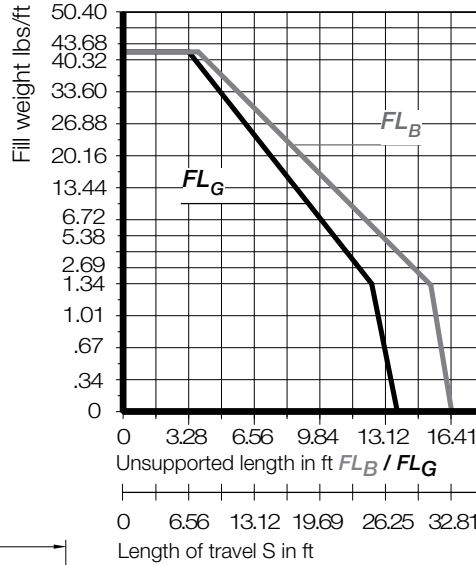
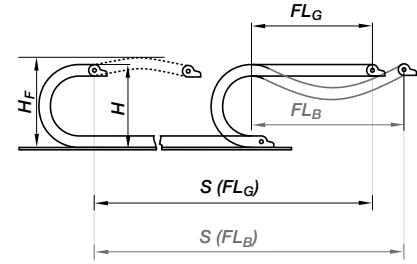

Pitch per link: = 3.58" (91 mm)  
 Links per ft (m): = 3.35 (11)  
 For center mount applications:  
 Chain length =  $\frac{S}{2} + K$

The required clearance height:  $H_F = H + 1.96$  in. (50 mm) (with 2.02 lbs/ft (3 kg/m) fill weight. Please consult igus® if space is particularly restricted.

R	*5.31 (135)	5.91 (150)	6.89 (175)	7.87 (200)	9.45 (240)	9.84 (250)	11.81 (300)	13.78 (350)	15.75 (400)	17.72 (450)	19.68 (500)
$H^{*+25}$	13.94 (354)	15.12 (384)	17.09 (434)	19.06 (484)	22.20 (564)	22.99 (584)	26.93 (684)	30.87 (784)	34.80 (884)	38.74 (984)	42.68 (1084)
D	12.36 (314)	12.95 (329)	13.94 (354)	14.92 (379)	16.50 (419)	16.89 (429)	18.86 (479)	20.83 (529)	22.79 (579)	24.76 (629)	26.73 (679)
K	24.02 (610)	25.79 (655)	28.94 (735)	32.09 (815)	37.01 (940)	38.19 (970)	44.29 (1125)	50.59 (1285)	56.69 (1440)	62.99 (1600)	69.09 (1755)

### For long travels with lowered mounting height

Long travel lengths from 32.8 ft.(10m) to max. 1,312.4 ft. (400m)

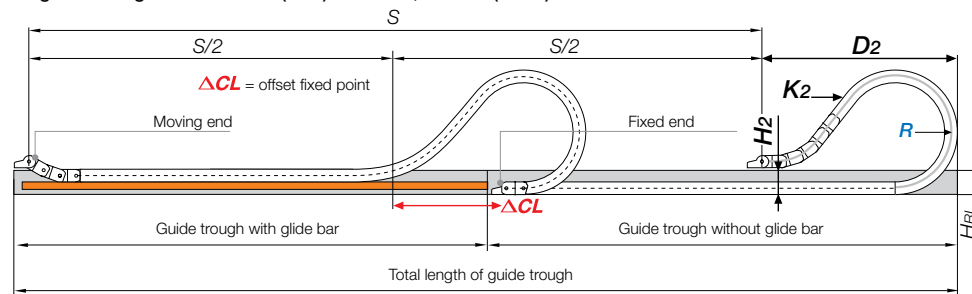

For center mount applications:  
 Chain length: =  $\frac{S}{2} + K_2$

### Long Travels - Gliding



If the unsupported length is exceeded, the e-chain®/ Tube must glide on itself. This requires a guide trough.

Design, Chapter 1

R	*5.31 (135)	5.91 (150)	6.89 (175)	7.87 (200)	9.45 (240)	9.84 (250)	11.81 (300)	13.78 (350)	15.75 (400)	17.72 (450)	19.68 (500)
$H_2$	10.63 (270)	10.47 (266)	10.47 (266)	10.47 (266)	10.47 (266)	10.47 (266)	10.47 (266)	10.47 (266)	10.47 (266)	10.47 (266)	10.47 (266)
$D_2$	10.55 (268)	17.72 (450)	22.83 (580)	27.95 (710)	35.43 (900)	38.58 (980)	46.46 (1180)	56.69 (1440)	60.24 (1530)	66.93 (1700)	72.83 (1850)
$K_2$	24.02 (610)	32.24 (819)	42.99 (1092)	50.16 (1274)	60.91 (1547)	64.49 (1638)	78.82 (2002)	89.57 (2275)	100.31 (2548)	114.64 (2912)	128.98 (3276)
$\Delta CL$	-	6.26 (159)	10.20 (259)	14.54 (359)	20.04 (509)	22.01 (559)	27.91 (709)	35.79 (909)	37.76 (959)	41.69 (1059)	45.63 (1159)

In case of travels between 32.8 and 39.4 ft (10 and 12 m) we recommend a longer unsupported length.

For support of the lower run, see Chapter 9 for the Support Tray tool kit

\*135 mm not available for the R4-56 e-chain

### Technical Data



Details of material properties

► Chapter 1

E4-56  
 H4-56  
 R4-56



### Short Travels - Unsupported

Unsupported e-chains® feature positive camber over short travels. This must be accounted for when specifying the clearance height. Please refer to Installation dimensions for further details.

### Legend

- S = Length of travel
- R = Bending radius
- H = Nominal clearance height
- D = Overlength e-chain® radius in final position
- $K = \pi \cdot R + \text{safety buffer}$
- $H_F$  = Required clearance height
- $H_{Ri}$  = Trough inner height
- $H_2$  = \*Mounting height
- $D_2$  = Overlength - long travels, gliding
- $K_2$  = \*Add-on

\*If the mounting bracket location is set lower

PDF: [igus.com/e-chain-pdfs](http://igus.com/e-chain-pdfs)  
 Product information: [igus.com/e-chains](http://igus.com/e-chains)



Series E4-56 - e-chain® with crossbars every link

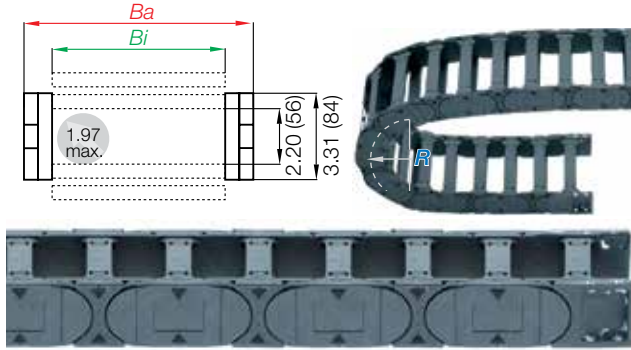

- Crossbars every link
- For use with rigid hydraulic hoses
- For particularly demanding applications
- Can be opened from both sides

Part Number Structure

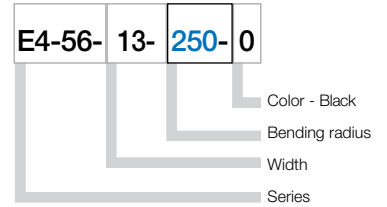

Series H4-56 - e-chain® with crossbars every other link

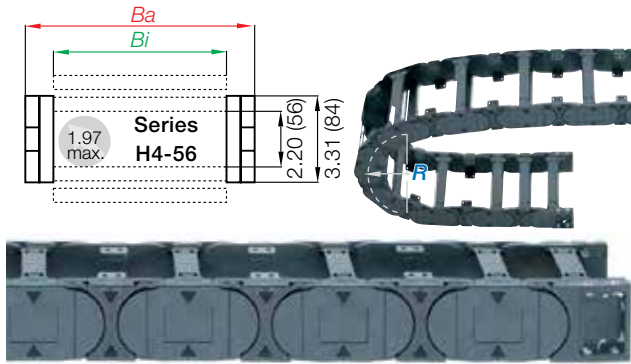

- Crossbars every other link
- Standard configuration
- For nearly every situation
- Can be opened from both sides
- Easy assembly
- Stable
- Cost-effective

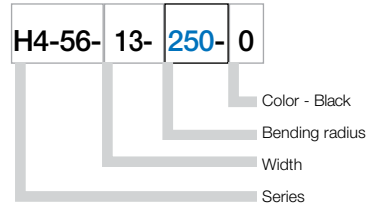

Series R4-56 - fully enclosed e-tube

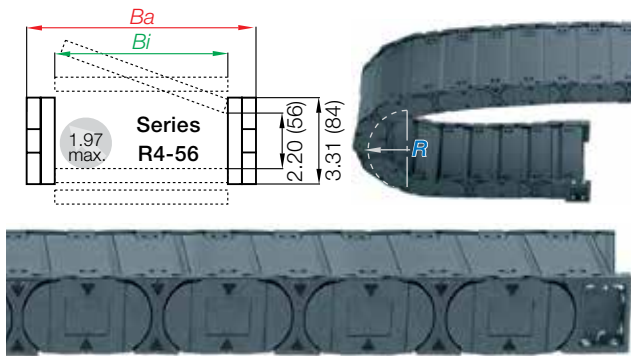

- Fully enclosed
- Excellent cable and hose protection against dirt
- Protection against hot chips
- Lids along inner radius are completely removable
- Lids along the outer radius are single-sided, snap open, hinged on one side as well as completely removable

Part Number Structure

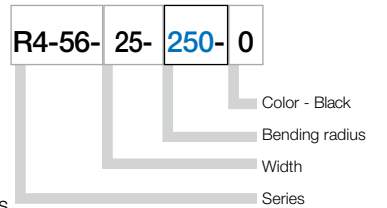

e-chain® as separate parts, links and side plates

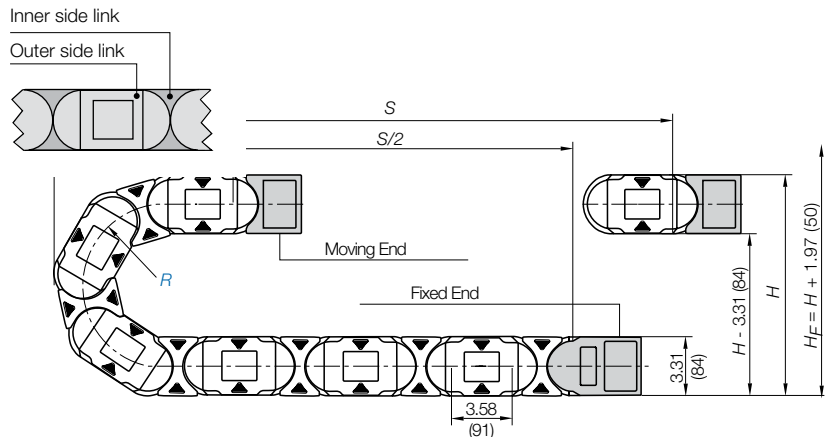
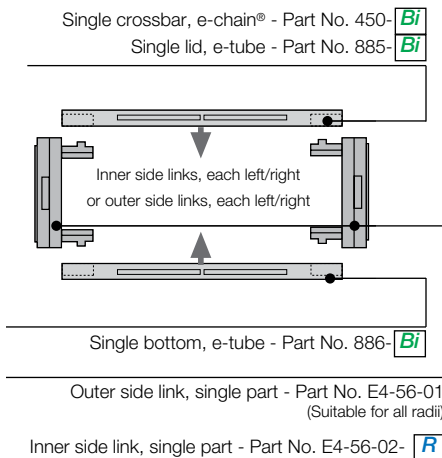

e-chain system® E4-1  
Series E4-56/H4-56/R4-56  
Product Range



E4-56  
H4-56  
R4-56

Part Number			Weight					
Crossbars	Crossbars	Tube	<i>Bi</i>	<i>Ba</i>	E4-56	H4-56	R4-56	
Every link	Every other	Version	in. (mm)	in. (mm)	lbs/ft (kg/m)	lbs/ft (kg/m)	lbs/ft (kg/m)	
E4-56-05-	H4-56-05-	<input type="checkbox"/> -0	1.97 (50)	3.31 (84)	≈ 2.22 (3.30)	≈ 2.12 (3.16)	-	
E4-56-055-	H4-56-055-	<input type="checkbox"/> -0	2.17 (55)	3.50 (89)	≈ 2.45 (3.65)	≈ 2.43 (3.62)	-	
E4-56-06-	H4-56-06-	<input type="checkbox"/> -0	2.56 (65)	3.90 (99)	≈ 2.28 (3.39)	≈ 2.15 (3.20)	-	
E4-56-07-	H4-56-07-	*R4-56-07-	2.95 (75)	4.29 (109)	≈ 2.33 (3.46)	≈ 2.18 (3.24)	≈ 2.63 (3.91)	
E4-56-08-	H4-56-08-	<input type="checkbox"/> -0	3.43 (87)	4.76 (121)	≈ 2.38 (3.54)	≈ 2.20 (3.28)	-	
E4-56-10-	H4-56-10-	R4-56-10-	3.94 (100)	5.28 (134)	≈ 2.44 (3.63)	≈ 2.23 (3.32)	≈ 2.82 (4.20)	
E4-56-11-	H4-56-11	<input type="checkbox"/> -0	4.41 (112)	5.79 (147)	≈ 2.52 (3.75)	≈ 2.27 (3.38)	-	
E4-56-12-	H4-56-12-	R4-56-12-	4.92 (125)	6.26 (159)	≈ 2.57 (3.83)	≈ 2.30 (3.42)	≈ 3.06 (4.56)	
E4-56-13-	H4-56-13-	<input type="checkbox"/> -0	5.39 (137)	6.77 (172)	≈ 2.66 (3.96)	≈ 2.35 (3.49)	-	
E4-56-15-	H4-56-15-	R4-56-15-	5.91 (150)	7.24 (184)	≈ 2.69 (4.00)	≈ 2.36 (3.51)	≈ 3.32 (4.94)	
E4-56-16-	H4-56-16-	<input type="checkbox"/> -0	6.38 (162)	7.76 (197)	≈ 2.76 (4.11)	≈ 2.39 (3.56)	-	
E4-56-169-	H4-56-169-	<input type="checkbox"/> -0	6.65 (169)	8.03 (204)	≈ 3.02 (4.49)	≈ 2.71 (4.03)	-	
E4-56-17-	H4-56-17-	R4-56-17	6.89 (175)	8.23 (209)	≈ 2.86 (4.25)	≈ 2.44 (3.63)	≈ 3.53 (5.25)	
E4-56-182-	H4-56-182-	<input type="checkbox"/> -0	7.16 (182)	8.54 (217)	≈ 3.08 (4.59)	≈ 2.74 (4.08)	-	
E4-56-18-	H4-56-18-	<input type="checkbox"/> -0	7.36 (187)	8.74 (222)	≈ 2.93 (4.36)	≈ 2.48 (3.69)	-	
E4-56-20-	H4-56-20-	R4-56-20-	7.87 (200)	9.21 (234)	≈ 2.96 (4.41)	≈ 2.49 (3.71)	≈ 3.74 (5.56)	
E4-56-207-	H4-56-207-	<input type="checkbox"/> -0	8.15 (207)	9.53 (242)	≈ 3.21 (4.77)	≈ 2.80 (4.17)	-	
E4-56-21-	H4-56-21-	<input type="checkbox"/> -0	8.35 (212)	9.72 (247)	≈ 3.01 (4.48)	≈ 2.52 (3.75)	-	
E4-56-22-	H4-56-22-	<input type="checkbox"/> -0	8.86 (225)	10.20 (259)	≈ 3.06 (4.55)	≈ 2.54 (3.78)	-	
E4-56-23-	H4-56-23-	<input type="checkbox"/> -0	9.33 (237)	10.71 (272)	≈ 3.13 (4.66)	≈ 2.58 (3.84)	-	
E4-56-25-	H4-56-25-	R4-56-25-	9.84 (250)	11.18 (284)	≈ 3.21 (4.77)	≈ 2.61 (3.89)	≈ 4.23 (6.29)	
E4-56-26-	H4-56-26-	<input type="checkbox"/> -0	10.31 (262)	11.69 (297)	≈ 3.27 (4.87)	≈ 2.65 (3.94)	-	
E4-56-27-	H4-56-27-	R4-56-27-	10.83 (275)	12.17 (309)	≈ 3.34 (4.97)	≈ 2.68 (3.99)	≈ 4.47 (6.65)	
E4-56-28-	H4-56-28-	<input type="checkbox"/> -0	11.30 (287)	12.68 (322)	≈ 3.38 (5.03)	≈ 2.70 (4.02)	-	
E4-56-30-	H4-56-30-	R4-56-30-	11.81 (300)	13.15 (334)	≈ 3.48 (5.18)	≈ 2.76 (4.10)	≈ 4.67 (6.95)	
E4-56-31-	H4-56-31-	<input type="checkbox"/> -0	12.28 (312)	13.66 (347)	≈ 3.50 (5.21)	≈ 2.76 (4.11)	-	
E4-56-32-	H4-56-32-	<input type="checkbox"/> -0	12.79 (325)	14.13 (359)	≈ 3.57 (5.32)	≈ 2.80 (4.17)	-	
E4-56-33-	H4-56-33-	<input type="checkbox"/> -0	13.27 (337)	14.65 (372)	≈ 3.66 (5.44)	≈ 2.84 (4.23)	-	
E4-56-35-	H4-56-35-	R4-56-35-	13.78 (350)	15.12 (384)	≈ 3.79 (5.64)	≈ 2.91 (4.33)	≈ 5.14 (7.65)	
E4-56-36-	H4-56-36-	<input type="checkbox"/> -0	14.25 (362)	15.63 (397)	≈ 3.73 (5.55)	≈ 2.88 (4.28)	-	
E4-56-37-	H4-56-37-	<input type="checkbox"/> -0	14.76 (375)	16.10 (409)	≈ 3.80 (5.65)	≈ 2.91 (4.33)	-	
E4-56-38-	H4-56-38-	<input type="checkbox"/> -0	15.24 (387)	16.61 (422)	≈ 3.87 (5.76)	≈ 2.95 (4.39)	-	
E4-56-40-	H4-56-40-	R4-56-40-	15.75 (400)	17.09 (434)	≈ 4.05 (6.03)	≈ 3.04 (4.52)	≈ 5.81 (8.65)	
E4-56-41-	H4-56-41-	<input type="checkbox"/> -0	16.22 (412)	17.60 (447)	≈ 4.00 (5.96)	≈ 3.01 (4.48)	-	
E4-56-42-	H4-56-42-	<input type="checkbox"/> -0	16.73 (425)	18.07 (459)	≈ 4.19 (6.23)	≈ 3.11 (4.63)	-	
E4-56-43-	H4-56-43-	<input type="checkbox"/> -0	17.20 (437)	18.58 (472)	≈ 4.09 (6.09)	≈ 3.06 (4.55)	-	
E4-56-45-	H4-56-45-	<input type="checkbox"/> -0	17.72 (450)	19.06 (484)	≈ 4.31 (6.42)	≈ 3.17 (4.72)	-	
E4-56-46-	H4-56-46-	R4-56-46-	18.19 (462)	19.57 (497)	≈ 4.28 (6.37)	≈ 3.15 (4.69)	≈ 6.13 (9.12)	
E4-56-47-	H4-56-47-	<input type="checkbox"/> -0	18.70 (475)	20.04 (509)	≈ 4.31 (6.41)	≈ 3.16 (4.71)	-	
E4-56-48-	H4-56-48-	<input type="checkbox"/> -0	19.17 (487)	20.55 (522)	≈ 4.48 (6.66)	≈ 3.25 (4.84)	-	
E4-56-50-	H4-56-50-	<input type="checkbox"/> -0	19.69 (500)	21.02 (534)	≈ 4.54 (6.76)	≈ 3.29 (4.89)	-	
E4-56-51-	H4-56-51-	<input type="checkbox"/> -0	20.16 (512)	21.54 (547)	≈ 4.48 (6.67)	≈ 3.25 (4.84)	-	
E4-56-52-	H4-56-52-	<input type="checkbox"/> -0	20.67 (525)	22.01 (559)	≈ 4.60 (6.84)	≈ 3.31 (4.93)	-	
E4-56-53-	H4-56-53-	<input type="checkbox"/> -0	21.14 (537)	22.52 (572)	≈ 4.66 (6.93)	≈ 3.34 (4.97)	-	
E4-56-55-	H4-56-55-	<input type="checkbox"/> -0	21.65 (550)	22.99 (584)	≈ 4.95 (7.36)	≈ 3.48 (5.18)	-	
E4-56-60-	H4-56-60-	<input type="checkbox"/> -0	23.62 (600)	24.96 (634)	≈ 5.09 (7.58)	≈ 3.56 (5.30)	-	

Choose from the radii below for all of the above sizes

Radius (mm) Example: E4-56-30--0

	135**	150	175	200	240	250	300	350	400	450	500
<i>R</i>	5.31 (135)	5.91 (150)	6.89 (175)	7.87 (200)	9.45 (240)	9.84 (250)	11.81 (300)	13.78 (350)	15.75 (400)	17.72 (450)	19.68 (500)
<i>H</i> <sup>25</sup>	13.94 (354)	15.12 (384)	17.09 (434)	19.06 (484)	22.20 (564)	22.99 (584)	26.93 (684)	30.87 (784)	34.80 (884)	38.74 (984)	42.68 (1084)
<i>D</i>	12.36 (314)	12.95 (329)	13.94 (354)	14.92 (379)	16.50 (419)	16.89 (429)	18.86 (479)	20.83 (529)	22.79 (579)	24.76 (629)	26.73 (679)
<i>K</i>	24.02 (610)	25.79 (655)	28.94 (735)	32.09 (815)	37.01 (940)	38.19 (970)	44.29 (1125)	50.59 (1285)	56.69 (1440)	62.99 (1600)	69.09 (1755)

\*\* This radius is not available for the R4-56 Series

\*Removable lid only, no hinged option

0 = Standard color black. For other colors see Chapter 1

For wider chains see page 6.69 For large diameter hoses see page 6.69

PDF: [igus.com/e-chain-pdfs](http://igus.com/e-chain-pdfs)  
Product information: [igus.com/e-chains](http://igus.com/e-chains)



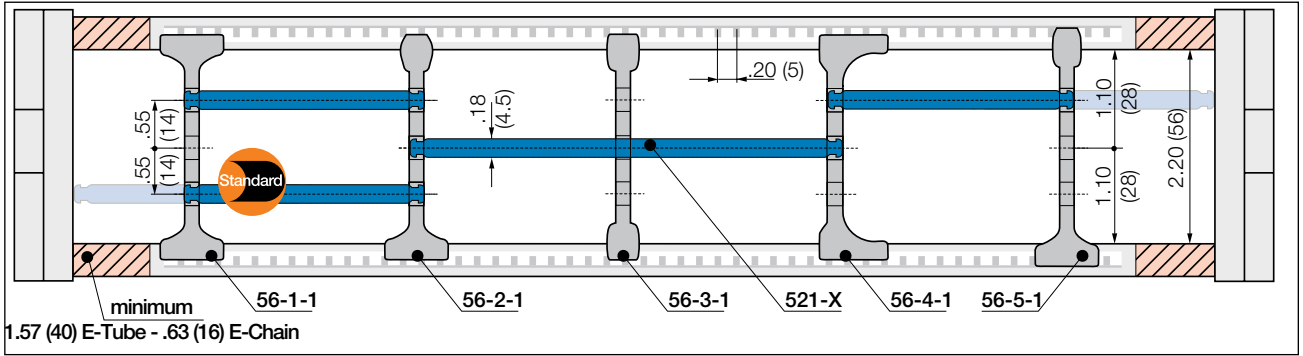

Note Please maintain a lateral spacing of 1.57" (40 mm) for e-tube and .63" (16 mm) for e-chains® between the separators and the side links. In the standard configuration separators are assembled every 2<sup>nd</sup> e-chain® link

Telephone 1-800-521-2747

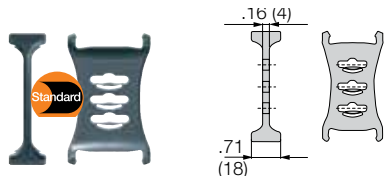

Separator, wide base

Unassembled Part No. 56-1  
Assembled Part No. 56-1-1

- **Standard separator 56-1 for all applications**

Separator with wide base for maximum locking strength and safe standing in e-chains®.

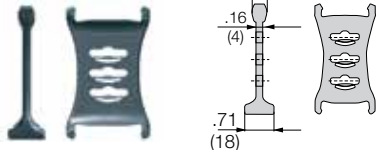

Separator, narrow head

Unassembled Part No. 56-2  
Assembled Part No. 56-2-1

- **Separator 56-2 For even faster installation**

is used when vertical and horizontal separation is required. Due to its slot, it allows basic vertical/horizontal shelving arrangements.

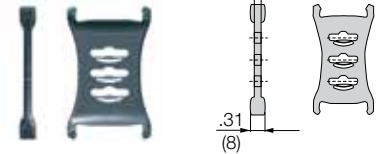

Separator, narrow base

Unassembled Part No. 56-3  
Assembled Part No. 56-3-1

- **Separator 56-3 For many thin cables**

is used when vertical and horizontal separation is required. Due to its slot, it allows basic vertical/horizontal shelving arrangements.

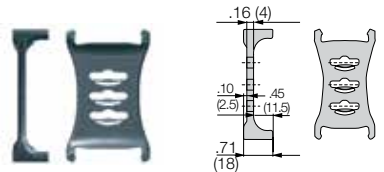

Separator, asymmetrical

Unassembled Part No. 56-4  
Assembled Part No. 56-4-1

- **Separator 56-4 For side mounted applications**

is used when vertical and horizontal separation is required. Due to its slot, it allows basic vertical/horizontal shelving arrangements.

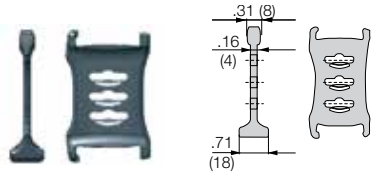

Separator, asymmetrical

Unassembled Part No. 56-5  
Assembled Part No. 56-5-1

- **Separator 56-5 Locks safely in .30" (7.5 mm) increments**  
Notch separator for exact positioning in e-chains®. Recommended for side-mounted applications.

Lockable full-width shelves - for the standard interior separation

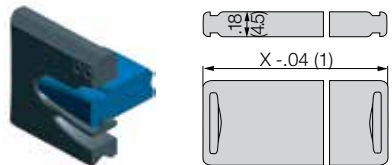

Full width shelf, lockable

Unassembled Part No. 520-X  
Assembled Part No. 521-X

- **Full width shelf, lockable**  
Shelf locks safely into separators on both ends, fixed width possible. Separators can be moved freely over the shelf in horizontal direction. Can be arranged at 3 different heights.

Width X	Part No.	Part No.	Width X	Part No.	Part No.	Width X	Part No.	Part No.
in. (mm)	Unassembled	Assembled	in. (mm)	Unassembled	Assembled	in. (mm)	Unassembled	Assembled
1.97 (050)	520-50	521-50	5.91 (150)	520-150	521-150	13.78 (350)	520-350	521-350
2.56 (065)	520-65	521-65	6.89 (175)	520-175	521-175	14.76 (375)	520-375	521-375
2.95 (075)	520-75	521-75	7.87 (200)	520-200	521-200	15.24 (387)	520-387	521-387
3.94 (100)	520-100	521-100	8.86 (225)	520-225	521-225	17.723 (450)	520-450	521-450
4.41 (112)	520-112	521-112	9.84 (250)	520-250	521-250			
4.92 (125)	520-125	521-125	11.81 (300)	520-300	521-300			

e-chain system® E4-1  
 Series E4-56/H4-56/R4-56  
 Interior Separation - New Generation



E4-56  
 H4-56  
 R4-56

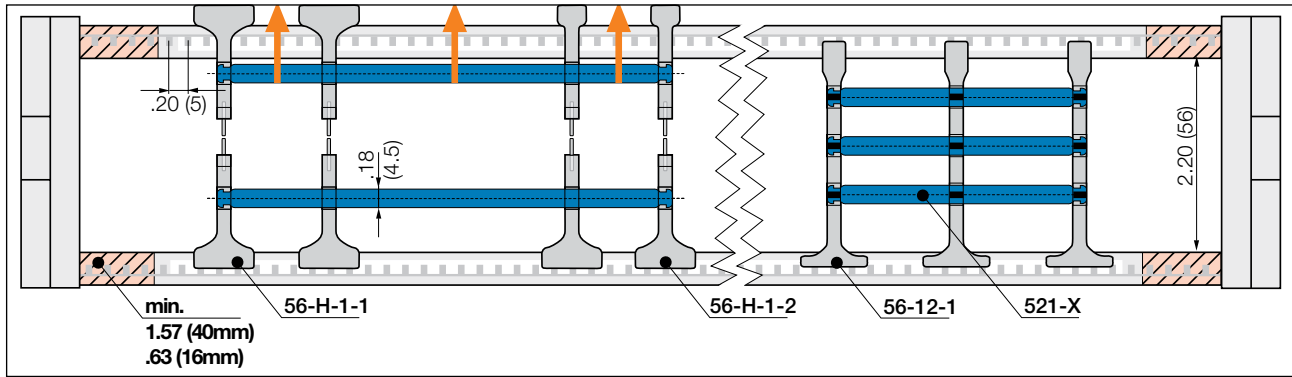

Note Please maintain a lateral spacing of 1.57" (40 mm) for e-tube and .63" (16 mm) for e-chains® between the separators and the side links. In the standard configuration separators are assembled every 2<sup>nd</sup> e-chain® link

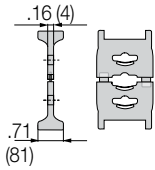

**Separator, wide base**

Unassembled **Part No. 56-H-1**  
 Assembled **Part No. 56-H-1-1**

• **Split separators for all applications**

In order to fill e-chains® more easily and effectively, these separators can be split in the middle. This allows easier access to middle shelf partitions. Fast assembly and easy retrofit. 2 types available: with wide or narrow top.

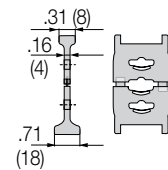
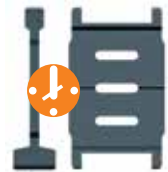

**Separator, narrow head**

Unassembled **Part No. 56-H-2**  
 Assembled **Part No. 56-H-2-1**

• **Lean separators 56-12**

New design allows extremely fast fitting of shelves in several layers, which significantly reduces assembly time. Enables extremely fast replacement of individual cables in a very full e-chain®.

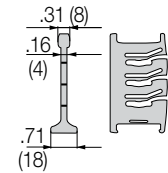

**Lean separator**

Unassembled **Part No. 56-12**  
 Assembled **Part No. 56-12-1**

• **Lean separator design - several layers of cables fitted quickly, save up to 50%\* assembly time**

(\*Lean separator vs. standard separator - measured on a 4m long e-chain® fitted with 12 cables in the igus® harnessing factory)



PDF: [igus.com/e-chain-pdfs](http://igus.com/e-chain-pdfs)  
 Product information: [igus.com/e-chains](http://igus.com/e-chains)





**Shelves and separators**

e-chains® and e-tubes can be subdivided both vertically and horizontally using the various interior separation elements.

► Design, Chapter 1 for layout recommendations.

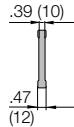
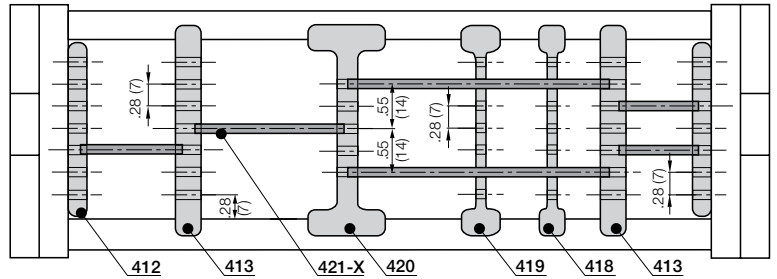

**Split separator (chain only)**

Unassembled	<b>Part No. T563</b>
Assembled	<b>Part No. T563M</b>

- **Split separator T563 for e-chains®**  
This separator is ideal for subsequent shelving or the initial assembly of the e-chain. Fast assembly and disassembly using a hinge/push mechanism. Enhances flexibility

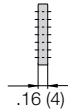

**Side plate**

Unassembled	<b>Part No. 402</b>
Assembled	<b>Part No. 412</b>

- **Side plates 402**  
This component is used to form the basic pattern of a shelf system.

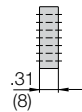

**Vertical separator**

Unassembled	<b>Part No. 403</b>
Assembled	<b>Part No. 413</b>

- **Vertical separator 403**  
This component is used to form the basic pattern of a shelf system.

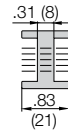

**Locking vertical separator**

Unassembled	<b>Part No. 410</b>
Assembled	<b>Part No. 420</b>

- **Locking vertical separator 410**  
This separator is slotted and able to be combined with shelves. For e-chains® only

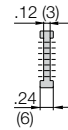
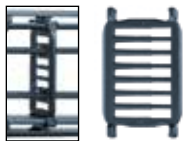

**Slotted separators, closed**

Unassembled	<b>Part No. 408</b>
Assembled	<b>Part No. 418</b>

- **Slotted separators 408**  
These are used for very complex subdivisions. However, they cannot be retrofitted into an existing separation system without removing the shelves first.

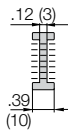

**Slotted separators, open**

Unassembled	<b>Part No. 409</b>
Assembled	<b>Part No. 419</b>

- **Slotted separator 409**  
This separator can be retrofitted into an existing interior separation system without removing the shelves, as long as these shelves fit into any of the 3 middle slots

**Shelves 420-XX**

These components form the basic pattern of a shelf system. Shelves of various widths can be arranged at 7 different heights in .28" (7mm) increments

Width X in. (mm)	Usable Width in. (mm)	Part No. Unassembled	Part No. Assembled	Width X in. (mm)	Usable Width in. (mm)	Part No. Unassembled	Part No. Assembled
.71 (18)	.39 (10)	<b>420-18</b>	<b>421-18</b>	2.95 (75)	2.64 (67)	<b>420-75</b>	<b>421-75</b>
.91 (23)	.59 (15)	<b>420-23</b>	<b>421-23</b>	3.46 (88)	3.15 (80)	<b>420-88</b>	<b>421-88</b>
.98 (25)	.67 (17)	<b>420-25</b>	<b>421-25</b>	3.94 (100)	3.62 (92)	<b>420-100</b>	<b>421-100</b>
1.10 (28)	.79 (20)	<b>420-28</b>	<b>421-28</b>	4.92 (125)	4.61(117)	<b>420-125</b>	<b>421-125</b>
1.30 (33)	.98 (25)	<b>420-33</b>	<b>421-33</b>	5.91 (150)	5.59(142)	<b>420-150</b>	<b>421-150</b>
1.69 (43)	1.38 (35)	<b>420-43</b>	<b>421-43</b>	6.89 (175)	6.57(167)	<b>420-175</b>	<b>421-175</b>
1.97 (50)	1.65 (42)	<b>420-50</b>	<b>421-50</b>	7.36 (187)	7.05(179)	<b>420-187</b>	<b>421-187</b>
2.44 (62)	2.13 (54)	<b>420-62</b>	<b>421-62</b>	7.87 (200)	7.56(192)	<b>420-200</b>	<b>421-200</b>

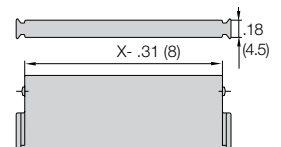

# e-chain system® E4-1

## Series E4-56/H4-56/R4-56

### Interior Separation - Previous Generation



E4-56  
H4-56  
R4-56



#### Vertical separators and spacers

Vertical separators are used if a vertical subdivision of the e-chain® interior is required. In standard configuration, a separator is installed every second chain link.

**NOTE:** Observe a lateral spacing of at least 1.26 in. (32mm) for e-tubes and .63 in. (16mm) for e-chain®. There is no minimum spacing needed for side plates

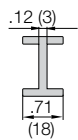
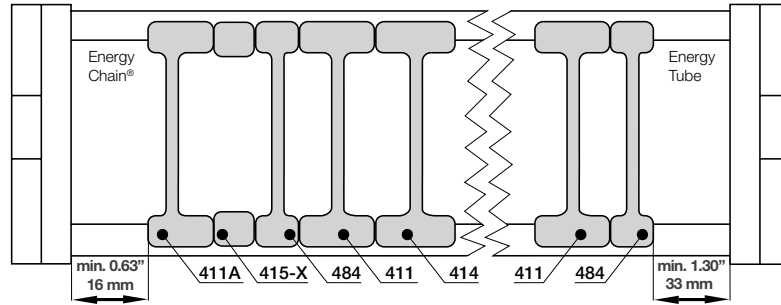

#### Vertical separator

Unassembled	<b>Part No. 401</b>
Assembled	<b>Part No. 411</b>

- **Standard separator 401 for e-chains® and e-tubes**  
This separator offers safe stability due to its wide base design.

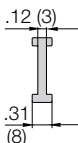

#### Vertical separator

Unassembled	<b>Part No. 483</b>
Assembled	<b>Part No. 484</b>

- **Vertical separator 483 for e-chains® and e-tubes**  
This separator offers a narrow base for applications where a large number of small cables need to be individually separated.

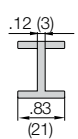

#### Locking separator (chain only)

Unassembled	<b>Part No. 404</b>
Assembled	<b>Part No. 414</b>

- **Locking separator 404 for e-chains®**  
This separator features increased retention force for applications exposed to very high humidity and extreme loads. The extra retention force is achieved by asymmetric claws for the crossbar. Take care to ensure proper alignment.

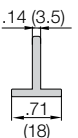

#### Locking separator (tube only)

Unassembled	<b>Part No. 406</b>
Assembled	<b>Part No. 416</b>

- **Locking separator 406 for e-tubes**  
It features a single sided, secure fit, and can be placed on the lid or the bottom of the e-tube. The single side locking design helps to eliminate difficulties in assembling the opposite cover or crossbar

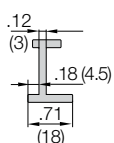

#### Asymmetrical separator (chain only)

Unassembled	<b>Part No. 401A</b>
Assembled	<b>Part No. 411A</b>

- **Asymmetrical separator 401A for e-chains®**  
This separator features an .71" (18mm) base. It can be used in combinations between spacers of different widths and vertical separators in side mounted applications.



#### Spacer (chain only)

Unassembled	<b>Part No. 405-XX</b>
Assembled	<b>Part No. 415-XX</b>

XX = width of the spacer

- **NOTE ON SPACERS**  
Vertical separators are adjustable, but can be fixed in position by means of a spacer. Spacers are most often necessary for side mounted applications.  
The available inner height is reduced by .08" (2mm) **per spacer** (for example if one spacer is placed on either side of the separator, the overall inner height is reduced by .16" (4mm). To avoid this, place the spacers on the **outside** of the opening crossbar (**not for long travels**).

Spacers available in the following sizes:

Part No. Unassembled	Part No. Assembled	in.	(mm)	Part No. Unassembled	Part No. Assembled	in.	(mm)
405 -10	415 -10	.39"	(10)	405 -30	415 -30	1.18"	(30)
405 -15	415 -15	.59"	(15)	405 -40	415 -40	1.57"	(40)
405 -20	415 -20	.79"	(20)				

PDF: [igus.com/e-chain-pdfs](http://igus.com/e-chain-pdfs)  
Product information: [igus.com/e-chains](http://igus.com/e-chains)





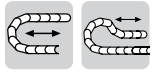

**Option 1: pivoting**  
**Standard**

- Recommended for unsupported and gliding applications
- Attachment capability on all sides
- Bolted connection outside of chain cross-section
- Space restricted conditions
- Corrosion resistant

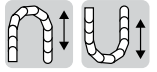

**Option 2: locking**

- Profile rail option
- Universal use
- Corrosion resistant
- Vertical hanging/standing travels
- Extreme accelerations

**Part Number Structure**

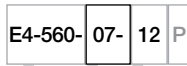

- With Profile Rail
- Complete Set
- Width
- E4-560 = Pivoting  
E4-561 = Locking

Due to the design of the E4-56 series chains,  
please note the following when ordering brackets:  
Even number of links = full set, part number ending in -12  
Odd number of links = 2 pieces, part number ending in -1

Moving end  
E4-560...1

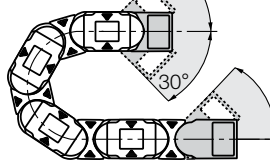

Fixed end  
E4-560...2

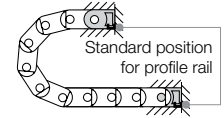

Moving end  
E4-561...1

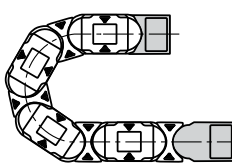

Fixed end  
E4-561...2

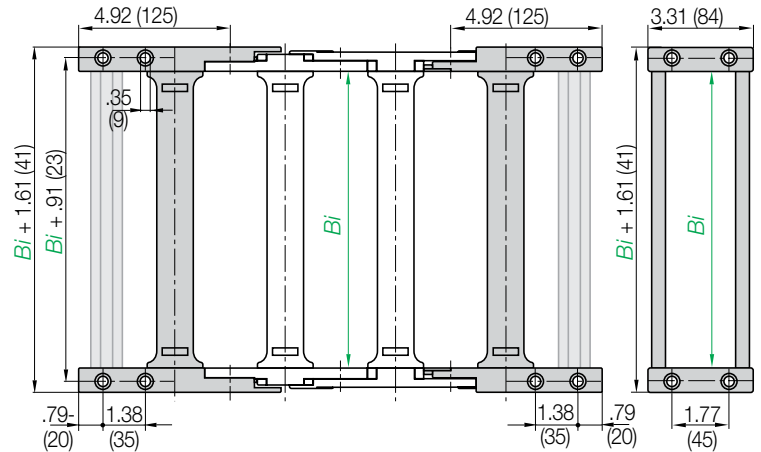
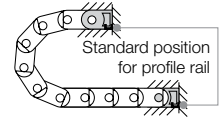

**Part No. Full Set (pivoting)**  
Series E4-56 or H4-56  
E4-560-Width-12

**Part No. Full Set (pivoting)**  
with profile rail  
Series E4-56 or H4-56  
E4-560-Width-12P

Part number examples are shown for pivoting brackets for e-chain. For locking brackets change part number to 561

idth	Part No. Full Set chain		With Profile Rail	Bi in. (mm)
	Pivoting	Locking		
-05*	E4-560	E4-561	-05-12 P	1.97 (50)
-055	E4-560	E4-561	-055-12 P	2.17 (55)
-06	E4-560	E4-561	-06-12 P	2.56 (65)
-07	E4-560	E4-561	-07-12 P	2.95 (75)
-08	E4-560	E4-561	-08-12 P	3.43 (87)
-10	E4-560	E4-561	-10-12 P	3.94 (100)
-11	E4-560	E4-561	-11-12 P	4.41 (112)
-12	E4-560	E4-561	-12-12 P	4.92 (125)
-13	E4-560	E4-561	-13-12 P	5.39 (137)
-15	E4-560	E4-561	-15-12 P	5.91 (150)
-16	E4-560	E4-561	-16-12 P	6.38 (162)
-169	E4-560	E4-561	-169-12 P	6.65 (169)
-17	E4-560	E4-561	-17-12 P	6.89 (175)
-182	E4-560	E4-561	-182-12 P	7.17 (182)
-18	E4-560	E4-561	-18-12 P	7.36 (187)
-20	E4-560	E4-561	-20-12 P	7.87 (200)
-207	E4-560	E4-561	-207-12 P	8.15 (207)
-21	E4-560	E4-561	-21-12 P	8.35 (212)
-22	E4-560	E4-561	-22-12 P	8.86 (225)
-23	E4-560	E4-561	-23-12 P	9.33 (237)
-25	E4-560	E4-561	-25-12 P	9.84 (250)
-26	E4-560	E4-561	-26-12 P	10.31 (262)
-27	E4-560	E4-561	-27-12 P	10.83 (275)

Width	Part No. Full Set chain		With Profile Rail	Bi in. (mm)
	Pivoting	Locking		
-28	E4-560	E4-561	-28-12 P	11.30 (287)
-30	E4-560	E4-561	-30-12 P	11.81 (300)
-31	E4-560	E4-561	-31-12 P	12.28 (312)
-32	E4-560	E4-561	-32-12 P	12.79 (325)
-33	E4-560	E4-561	-33-12 P	13.27 (337)
-35	E4-560	E4-561	-35-12 P	13.78 (350)
-36	E4-560	E4-561	-36-12 P	14.25 (362)
-37	E4-560	E4-561	-37-12 P	14.76 (375)
-38	E4-560	E4-561	-38-12 P	15.24 (387)
-40	E4-560	E4-561	-40-12 P	15.75 (400)
-41	E4-560	E4-561	-41-12 P	16.22 (412)
-42	E4-560	E4-561	-42-12 P	16.73 (425)
-43	E4-560	E4-561	-43-12 P	17.20 (437)
-45	E4-560	E4-561	-45-12 P	17.72 (450)
-46	E4-560	E4-561	-46-12 P	18.19 (462)
-47	E4-560	E4-561	-47-12 P	18.70 (475)
-48	E4-560	E4-561	-48-12 P	19.17 (487)
-50	E4-560	E4-561	-50-12 P	19.69 (500)
-51	E4-560	E4-561	-51-12 P	20.16 (512)
-52	E4-560	E4-561	-52-12 P	20.67 (525)
-53	E4-560	E4-561	-53-12 P	21.14 (537)
-55	E4-560	E4-561	-55-12 P	21.65 (550)
-60	E4-560	E4-561	-60-12 P	23.62 (600)

# e-chain system® E4-1

## Series E4-56/H4-56/R4-56

### Mounting Brackets



E4-56  
H4-56  
R4-56

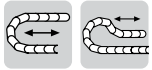

#### Option 1: pivoting



- Recommended for unsupported and gliding applications
- Attachment capability on all sides
- Bolted connection outside of chain cross-section
- Space restricted conditions
- Corrosion resistant

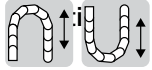

#### locking

- Profile rail option
- Universal use
- Corrosion resistant
- Vertical hanging/standing travels
- Extreme accelerations

Moving end  
E4-560...1

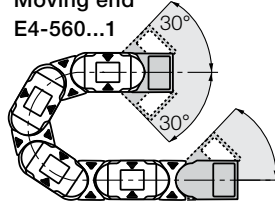

Fixed end  
E4-560...2

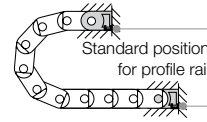

Moving end  
E4-561...1

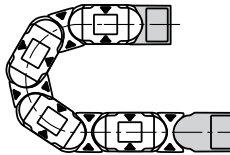

Fixed end  
E4-561...2

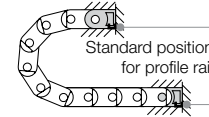

#### Part Number Structure

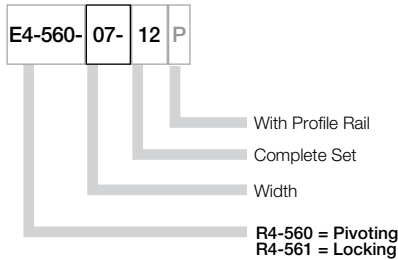

Due to the design of the E4-56 series chains, please note the following when ordering brackets:  
Even number of links = full set, part number ending in -12  
Odd number of links = 2 pieces, part number ending in -1

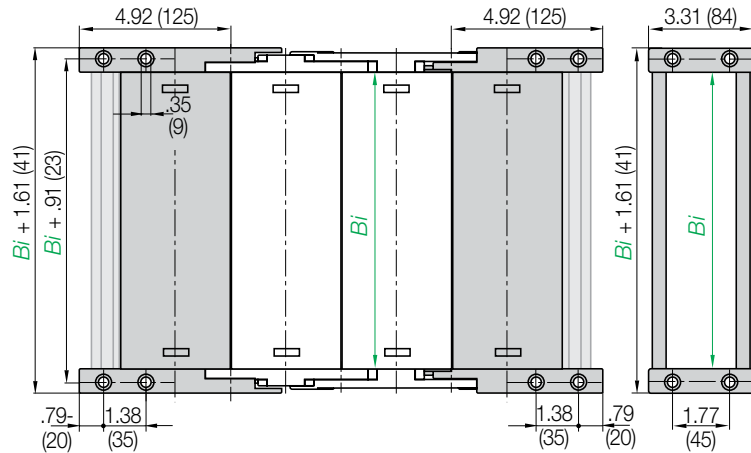

#### Part No. Full Set (pivoting)

Tube Series R4-56

R4-560-Width-12

#### Part No. Full Set (pivoting)

with Profile Rail

Tube Series R4-56

R4-560-Width-12P

Part number examples are shown for pivoting brackets for e-chain. For locking brackets change part number to 561

Width	Part No. Full Set tube		With Profile Rail	<i>Bi</i> in. (mm)	Part No. Full Set tube		With Profile Rail	<i>Bi</i> in. (mm)			
	Pivoting	Locking			Pivoting	Locking					
-07	R4-560	R4-561	-07-12		2.95 (75)	-25	ER4-560	R4-561	-25-12		9.84 (250)
-10	R4-560	R4-561	-10-12		3.94 (100)	-27	R4-560	R4-561	-27-12		10.83 (275)
-12	R4-560	R4-561	-12-12		4.92 (125)	-30	R4-560	R4-561	-30-12		11.81 (300)
-15	R4-560	R4-561	-15-12		5.91 (150)	-35	R4-560	R4-561	-35-12		13.78 (350)
-17	R4-560	R4-561	-17-12		6.89 (175)	-40	R4-560	R4-561	-40-12		15.75 (400)
-20	R4-560	R4-561	-20-12		7.87 (200)	-46	R4-560	ER4-561	-46-12		18.19 (462)

PDF: [igus.com/e-chain-pdfs](http://igus.com/e-chain-pdfs)  
Product information: [igus.com/e-chains](http://igus.com/e-chains)



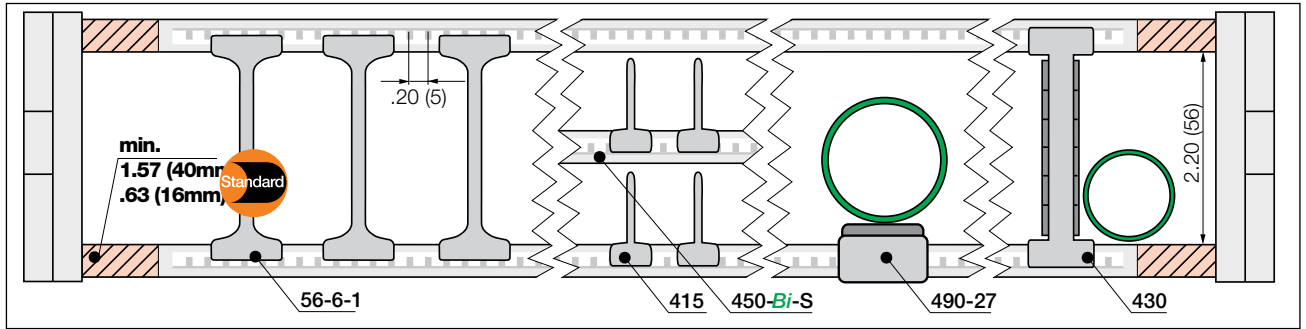

Note Please maintain a lateral spacing of 1.57" (40 mm) for e-tube and .63" (16 mm) for e-chains® between the separators and the side links. In the standard configuration separators are assembled every 2<sup>nd</sup> e-chain® link

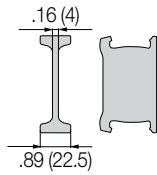

**Notch locking separator**

Unassembled	<b>Part No. 56-6</b>
Assembled	<b>Part No. 56-6-1</b>

● **Notch locking separator for increased holding force**

Notch locking separators offer higher crossbar opening forces for high humidity and/or large hydraulic hoses. They can be positioned precisely and then locked in position.

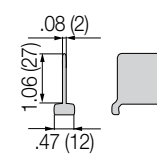

**Partial height separator**

Unassembled	<b>Part No. 405</b>
Assembled	<b>Part No. 415</b>

● **Partial height separator\***

In conjunction with an additional opening crossbar, **part no. 450-Bi-S**, it provides the option to separate the upper and lower halves of the e-chain® independently of each other.

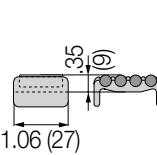

**Rollclip\* for e-chains®**

Unassembled	<b>Part No. 489-27</b>
Assembled	<b>Part No. 490-27</b>

● **Rollclip\***

Minimizes abrasion of sensitive hoses. Simply clamps onto the opening crossbar. The movable rollers compensate for relative movement between the e-chain® and hose.

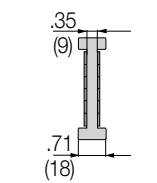

**Roller separator for e-chains®**

Unassembled	<b>Part No. 429</b>
Assembled	<b>Part No. 430</b>

● **Roller separator\***

The roller separator is used in a similar way to the rollclip. It is used like a separator. For rigid cables and hoses.

\*Only for e-chains®

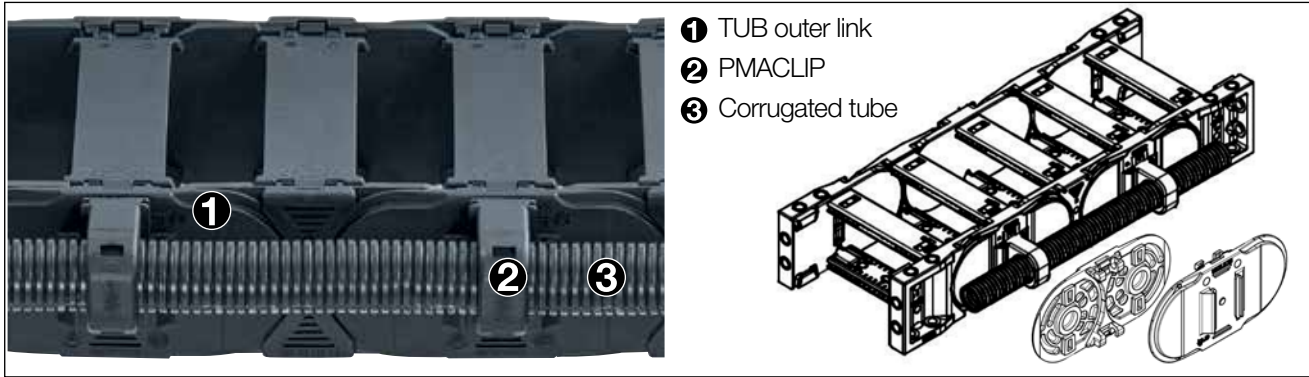

**TUB | Safe guidance for corrugated tubes parallel to the e-chain®**

- Additional, simple guidance for corrugated tubes on the outside of the e-chain®
- PMACLIP allows corrugated tubes with nominal widths .28 (07mm), .39 (10mm), .47 (12mm), .67 (17mm) to be easily clipped on
- Easy access to the corrugated tubes, fast replacement of the hoses
- Reduce assembly time and cost - easy to assemble, without any additional screws or tools
- The part number includes the e-chain® with TUB side sections; the PMACLIP support and the hose are ordered separately

Part No. TUB	Part No. TUB	Part No. TUB	For corrugated tube nominal diameter
Outer link right*	Outer link left*	Outer link at both ends*	Ø [mm]
E4-56-XXXTUBR-R-0	E4-56-XXXTUBL-L-R-0	E4-56-XXXTUB-R-0	.28 (07), .39 (10), .47 (12), .67 (17)

\*View from the fixed end

Part number appended with width index **XXX Bi** and radius (**R**) e.g.

E4-56-100TUBR-150-0 = with TUB outer sections every 2<sup>nd</sup> right hand link

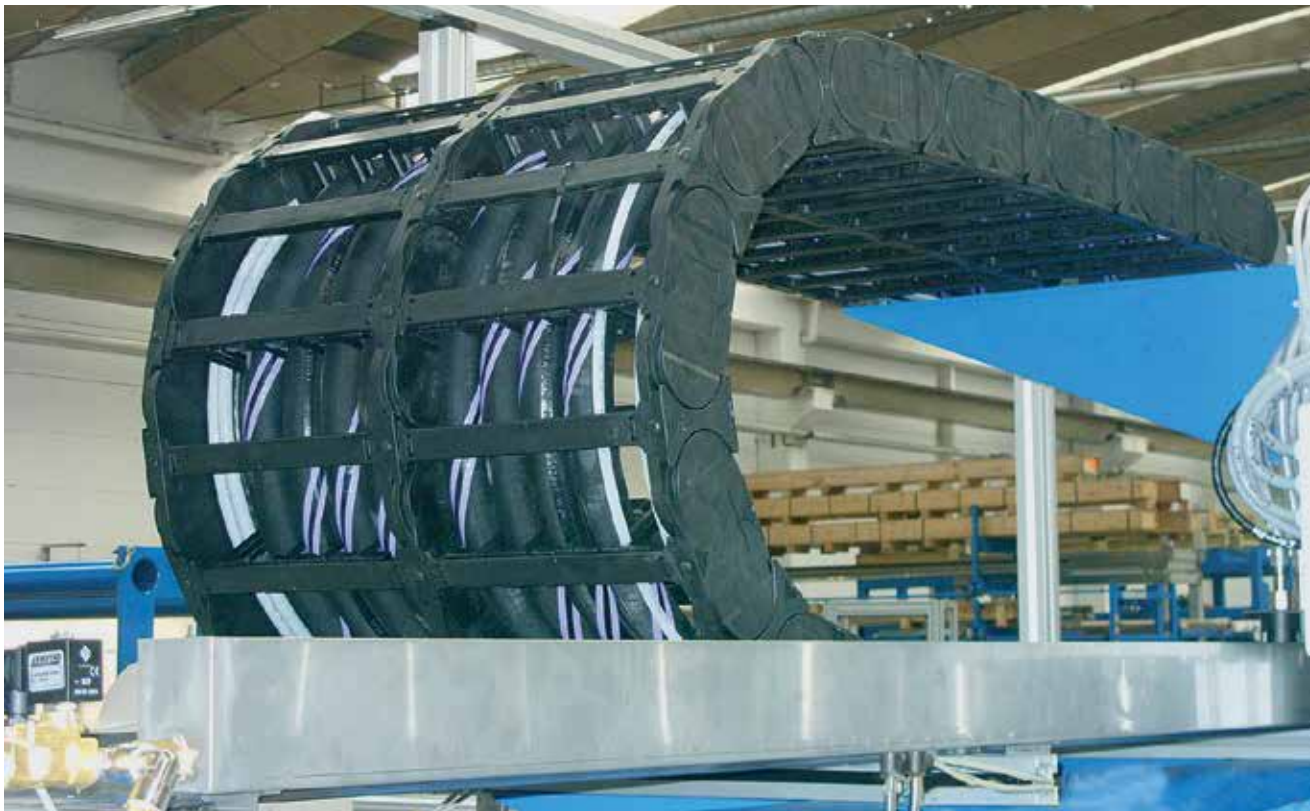

E4-1 as a noise-optimized version with extension links. Unsupported application with high fill weight. Assembled with rigid hydraulic hoses. The max. noise level can be reduced up to 9dB(A) using the optional rubber dampers





**Extension links - for extremely wide e-chains® up to 9.84 ft (3m)**

- For applications in which particularly high fill weights necessitate extremely wide e-chains®
- The extension link design allows virtually limitless side-by-side attachment of chains
- The unsupported length of a chain can be increased when additional loads are required
- Extension links can be used with e-chains®, e-tubes or a combination of both
- They are suitable for unsupported and gliding applications in a guide trough
- e-chains® with extension links are attached with KMA or steel mounting brackets.

Part number example for e-chain®

E4-56-10/20/10- 200 -0

E4-56-*Bi1/Bi2/Bi3*- R -0

We strongly recommend on-site consultation with an igus® technician for individual advice regarding mounting brackets, guide troughs and other design details.

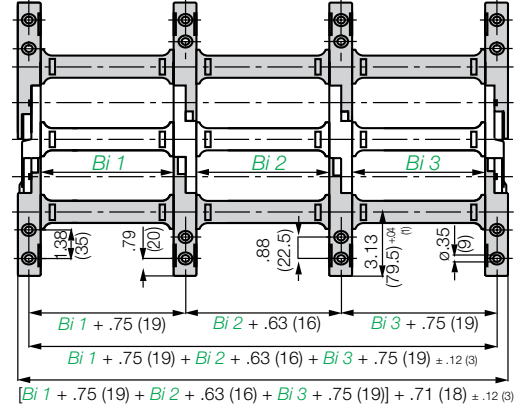

Consult igus® for your extender crossbar applications. We will be happy to assist you with your design layout.

**Extender crossbars - For careful guiding of large diameter cables and hoses**

- Intended for cables and hoses with a maximum outer diameter of 9.65 in. (245 mm).
- Can be attached along either the inner or outer radius, inner radius preferred
- Gliding operation with crossbars assembled along the outer radius in conjunction with a special guide trough
- Gliding operation not guaranteed with crossbars assembled along the inner radius
- The extender crossbar can either be attached to the side links directly or can be used in combination with two standard snap-open crossbars.

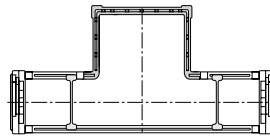

Square extender crossbar combined with standard snap-open crossbars.

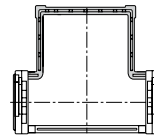

Attached directly to the side link.

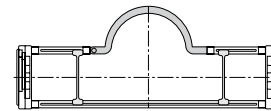

Round extender crossbar combined with standard snap-open crossbars.

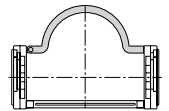

Attached directly to the side link.

Part No.	Max Ø Hose	Style	Installation Side Link	Combined with Snap-Open Crossbars
450-15-RHD115	4.52 (115)	Round	No	Yes
450-17-RD115	4.52 (115)	Round	Yes	No
450-25-D150	5.91 (150)	Square	Yes	No
450-30-D200	7.09 (180)	Square	Yes	No
450-35-D250	7.68 (195)	Square	Yes	No
450-40-D300	9.65 (245)	Square	Yes	No
450-20-HD150	5.91 (150)	Square	No	Yes
450-25-HD200	7.09 (180)	Square	No	Yes
450-30-HD250	7.68 (195)	Square	No	Yes

**Chainfix clamps for the profile rail**

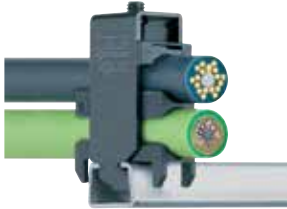

For more information please refer to strain relief section of Chapter 10.

igus® Chainfix strain relief elements are available in either steel or stainless steel. They can be adjusted with a hexagon socket and are available in single, double and triple configurations.

Part No. Single Clamp		Part No. Double Clamp		Part No. Triple Clamp		Cable ø	
Steel	Stainless	Steel	Stainless	Steel	Stainless	in.	(mm)
CFX12-1	CFX12-1E	CFX12-2	CFX12-2E	CFX12-3	-	.24 - .47	(6 - 12)
CFX14-1	CFX14-1E	CFX14-2	CFX14-2E	CFX14-3	-	.47 - .55	(12 - 14)
CFX16-1	CFX16-1E	CFX16-2	CFX16-2E	CFX16-3	-	.55 - .63	(14 - 16)
CFX18-1	CFX18-1E	CFX18-2	CFX18-2E	CFX18-3	-	.63 - .71	(16 - 18)
CFX20-1	CFX20-1E	CFX20-2	CFX20-2E	CFX20-3	-	.71 - .79	(18 - 20)
CFX22-1	CFX22-1E	CFX22-2	CFX22-2E	CFX22-3	-	.79 - .87	(20 - 22)
CFX26-1	CFX26-1E	CFX26-2	CFX26-2E	-	-	.87 - 1.02	(22 - 26)
CFX30-1	CFX30-1E	CFX30-2	CFX30-2E	-	-	1.02 - 1.18	(26 - 30)
CFX34-1	CFX34-1E	CFX34-2	CFX34-2E	-	-	1.18 - 1.34	(30 - 34)
CFX38-1	CFX38-1E	-	-	-	-	1.34 - 1.50	(34 - 38)
CFX42-1	CFX42-1E	-	-	-	-	1.50 - 1.65	(38 - 42)

**Tiewrap Plates**

**Option 1:  
Tiewrap plates as an individual part**

Available as an individual component, can be fixed onto a mounting bracket with the use of a profile rail.

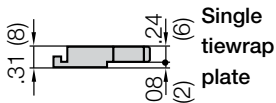
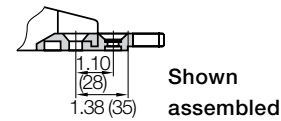

Tiewrap Plate	n Number of Teeth	C Overall Width in. (mm)	B Bore Width in. (mm)	Center Bore
3050-ZB	5	1.97 (50)	1.18 (30)	no
3075-ZB	7	2.95 (75)	2.16 (55)	no
3100-ZB	10	3.94 (100)	3.15 (80)	no
3115-ZB	11	4.53 (115)	3.74 (95)	no
3125-ZB	12	4.92 (125)	4.13 (105)	no
3150-ZB	15	5.91 (150)	5.12 (130)	no
3175-ZB	17	6.89 (175)	6.10 (155)	no
3200-ZB	20	7.87 (200)	7.09 (180)	yes
3225-ZB	22	8.86 (225)	8.07 (205)	yes
3250-ZB	25	9.84 (250)	9.06 (230)	yes

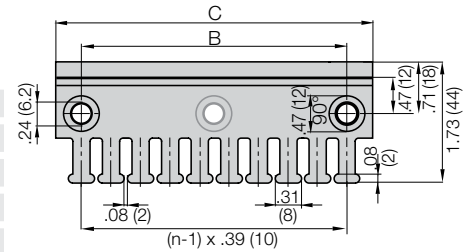

If used with KMA brackets with profile rail please add "KMA" to the end of the part number.

**Example: 3050-ZBKMA**

For more information please refer to strain relief section of Chapter 10

**Option 2:  
Clip-on Tiewrap plates**

Available as a clip-on tiewrap plate without the use of bolts They are inserted and removed with a screwdriver used as a lever. Clip-on tiewrap plates are also available as an attachment to the opening crossbars.



Part No.	Number of Teeth	Width of Strain Relief in. (mm)
3050-ZC	5	1.97 (50)
3075-ZC	7	2.95 (75)

For more information please refer to strain relief section of Chapter 10.

**Option 3:  
Clip-on Tiewrap plates for opening crossbars**

Clip-on tiewrap plates are also available as an attachment to opening crossbars. They can be positioned at any point along the e-chain®.



Part No.	Number of Teeth	Width of Strain Relief in. (mm)
4550-ZS	5	1.89 (48)
4575-ZS	7	2.91 (74)

For more information please refer to strain relief section of Chapter 10



Width of Crossbar  
E4-56-05-200-0

	$B_{Ri}$	
-05	3.50 (89)	*
-06	4.09 (104)	94-50-225
-07	4.49 (114)	94-50-225
-08	5.04 (128)	94-50-250
-10	5.47 (139)	94-50-250
-11	5.98 (152)	94-50-275
-12	6.46 (164)	94-50-275
-13	6.97 (177)	94-50-300
-15	7.44 (189)	94-50-300
-16	7.95 (202)	94-50-325
-17	8.42 (214)	94-50-325
-18	8.94 (227)	94-50-350
-20	9.41 (239)	94-50-350
-21	9.92 (252)	94-50-375
-22	10.39 (264)	94-50-375
-23	10.91 (277)	94-50-400
-25	11.38 (289)	94-50-400
-26	11.89 (302)	94-50-425
-27	12.36 (314)	94-50-425
-28	12.87 (327)	94-50-450
-30	13.35 (339)	94-50-450
-31	13.86 (352)	94-50-475
-32	14.33 (364)	94-50-475
-33	14.84 (377)	94-50-500
-35	15.31 (389)	94-50-500
-36	15.82 (402)	94-50-525
-37	16.30 (414)	94-50-525
-38	16.81 (427)	94-50-550
-40	17.28 (439)	94-50-550
-41	17.79 (452)	94-50-575
-42	18.27 (464)	94-50-575
-43	18.78 (477)	94-50-600
-45	19.25 (489)	94-50-600
-46	19.76 (502)	94-50-625
-47	20.24 (514)	94-50-625
-48	20.75 (527)	94-50-650
-50	21.22 (539)	94-50-650
-51	21.73 (552)	94-50-675
-52	22.20 (564)	94-50-675
-53	22.72 (577)	94-50-700
-55	23.19 (589)	94-50-700
-60	25.16 (639)	94-50-750

Installation  
Part No.

Guide troughs are used with applications where the upper run of the e-chain® glides on the lower run. If using igus® steel guide troughs, the following components are required.

- Full travel length of guide trough  
**Part No. 94-30**
- 1/2 travel length glide bars  
**Part No. 93-01**
- Installation sets as end connectors  
**Part No. 94-50-XX**

.XX indicates the length of the profile rails on which the guide trough is mounted. The values and part numbers are specified in the table on the left. The standard length of the trough components and glide bars is 6.56 ft (2m). The required overall length of the guide trough directly correlates to the length of travel.

**Example:**

Length of travel 164 ft (50 m)  
Center mounted

**Required guide troughs:**

164 ft (50 m) guide trough  
82 ft (25 m) glide bars  
= 25 sections of 6.56 ft (2 m) guide trough  
**Part No. 94-30**  
= 13 sections of 6.56 ft (2 m) glide bars

**Part No. 93-01**

**Required number of installation sets:**

= Number of guide trough components + 1  
= 25 + 1 = 26  
Part number of the installation sets  
**94-50-XXX**

**Example:**

94-50-400 for 15.75 (400 mm) long profile rail

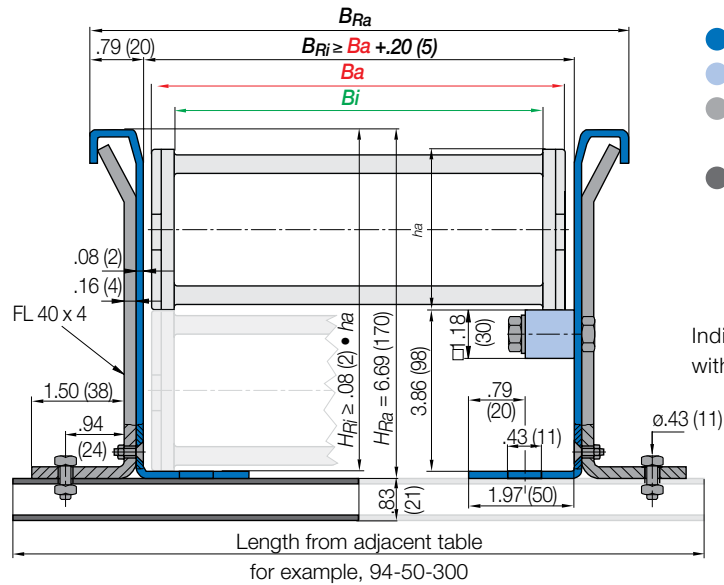

- Guide trough
- Glide bars
- Installation set "Basic"
- Profile rail

Individual attachment without profile rail

\* Specialized guide trough available upon request

Standard length profile rail



Left: Guide trough with glide bars  
Right: Guide troughs without glide bars



Installation sets as section connectors