

Features

- Meets the ISO 11898-2:2016 and SAE J2284-1 to SAE J2284-5 Physical Layer Standards
- Supports CAN FD and Data Rating up to 5 Mbps
- Short Propagation Delay Times and Fast Loop Times
- 5-V Power Supply, I/O Voltage Range Supports 2.8-V to 5.5-V MCU Interface
- Common-Mode Input Voltage: ± 30 V
- Protection Feature:
 - IEC 61000-4-2 ESD Protection up to ± 15 kV
 - Bus Fault Protection: ± 42 V
 - VCC and VIO (TPT1256 only) Under-voltage Protection
 - TXD Dominant Time-out Function and Bus-Dominant Time-out Function
 - Thermal Shutdown Protection
- Available in SOP8 Package and Leadless DFN3X3 Package

Applications

- All Devices Supporting Highly Loaded CAN Networks
- Field Industrial Automation, Sensors, and Drive Systems
- Building, Security Control Systems
- Energy Storage systems
- Telecom Base Station Status and Control

Description

The TPT125x device is a CAN transceiver that meets the ISO11898 High-speed CAN (Controller Area Network) physical layer standard. The device is designed to be used in CAN FD networks up to 5 Mbps, and to enhance timing margin and higher data rates in long and high-loading networks. As designed, the device features cross-wire, overvoltage, and loss of ground protection from -42 V to $+42$ V, overtemperature shutdown, and a -30 V to $+30$ V common-mode range. The TPT1256 has a secondary power supply input for I/O level shifting the input pin thresholds and RXD output level. The device comes with a silent mode which is also commonly referred to as listen-only mode, and it includes many protection features to enhance device and network robustness.

The TPT125x is available in SOP-8 and DFN3X3-8L packages and characterized from -40°C to $+125^{\circ}\text{C}$.

Typical Application Circuit

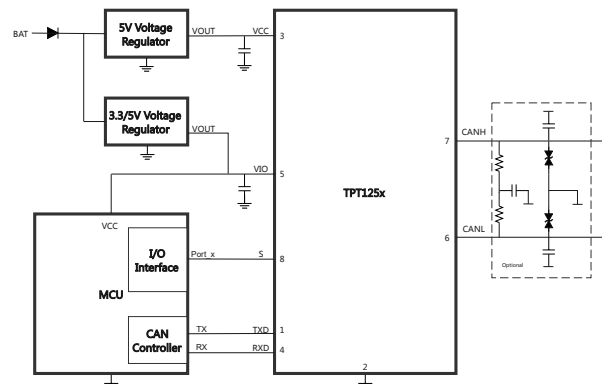

Table of Contents

Features	1
Applications	1
Description	1
Typical Application Circuit	1
Product Family Table	3
Revision History	3
Pin Configuration and Functions	4
Specifications	6
Absolute Maximum Ratings	6
ESD(Electrostatic Discharge Protection).....	6
Recommended Operating Conditions.....	7
Thermal Information.....	7
Electrical Characteristics.....	8
AC Timing Requirements.....	11
Detailed Description	13
Overview.....	13
Functional Block Diagram.....	13
Feature Description.....	13
Application and Implementation	15
Application Information	15
Typical Application.....	15
Tape and Reel Information	16
Package Outline Dimensions	17
SOP8.....	17
DFN3X3-8.....	18
Order Information	19
IMPORTANT NOTICE AND DISCLAIMER	20

Product Family Table

Order Number	VCC (V)	VIO (V)	BUS Protection (V)	Package
TPT1255-SO1R	4.5 to 5.5	NC	±42	SOP-8
TPT1256-SO1R	4.5 to 5.5	2.8 to 5.5	±42	SOP-8
TPT1255-DF6R	4.5 to 5.5	NC	±42	DFN3X3-8L
TPT1256-DF6R	4.5 to 5.5	2.8 to 5.5	±42	DFN3X3-8L

Revision History

Date	Revision	Notes
2021-06-18	Rev.Pre.0	Initial Version
2022-04-26	Rev.A.0	Released version
2022-05-26	Rev.A.1	Updated the notes of Order Information
2022-06-17	Rev.A.2	Updated the DFN package POD, tape and reel Information of the DFN
2022-08-05	Rev.A.3	Updated the description of TPT1256 pin VIO
2023-06-20	Rev.A.4	Updated the new format

Pin Configuration and Functions

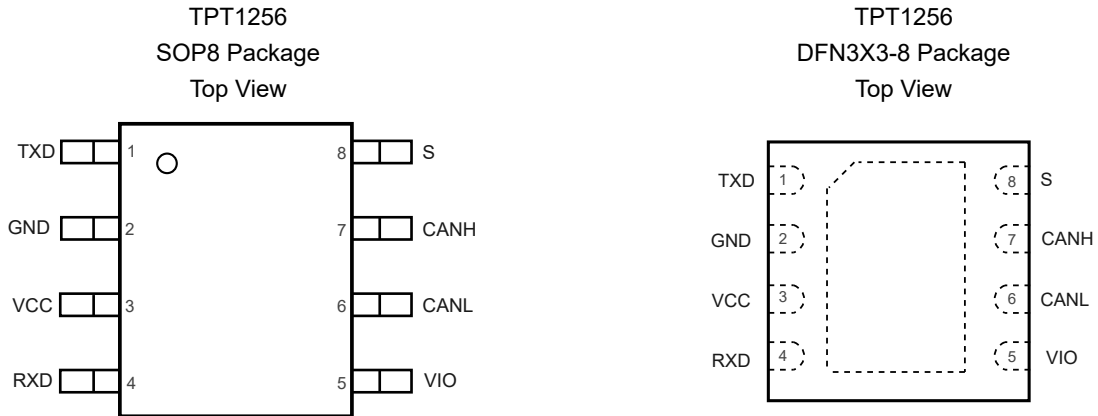
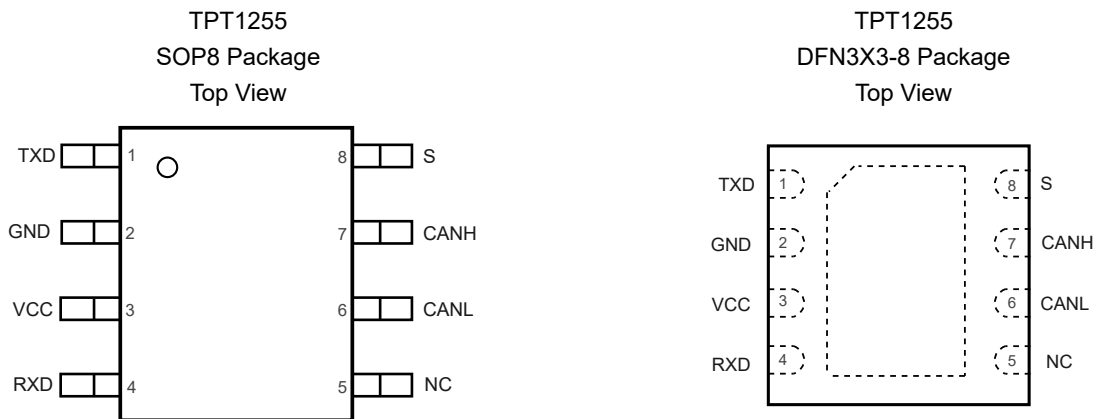

Table 1. Pin Functions: TPT1256

Pin		I/O	Description
No.	Name		
1	TXD	I	CAN transmit data input (LOW for dominant and HIGH for recessive bus states)
2	GND	GND	Ground
3	VCC	POWER	Transceiver 5 V supply voltage
4	RXD	O	CAN receive data output (LOW for dominant and HIGH for recessive bus states)
5	VIO	POWER	Transceiver I/O level shifting supply voltage
6	CANL	BUS I/O	Low level CAN bus input/output line
7	CANH	BUS I/O	High level CAN bus Input/output line
8	S	I	Silent (listen-only) mode , Mode control (Active High)

Fault Protected High-Speed CAN FD Transceiver with Silent Mode

Table 2. Pin Functions: TPT1255

Pin		I/O	Description
No.	Name		
1	TXD	I	CAN transmit data input (Low for dominant and High for recessive bus states)
2	GND	GND	Ground
3	VCC	Power	Transceiver 5 V supply voltage
4	RXD	O	CAN receive data output (Low for dominant and High for recessive bus states)
5	NC	-	Not Connected
6	CANL	Bus I/O	Low-level CAN bus input/output line
7	CANH	Bus I/O	High-level CAN bus input/output line
8	S	I	Silent (listen-only) mode , Mode control (Active High)

Specifications

Absolute Maximum Ratings

Parameter		Min	Max	Unit
V _{CC}	5-V Bus Supply Voltage Range	-0.3	7	V
V _{IO}	I/O Level-Shifting Voltage Range	-0.3	7	V
V _{BUS}	Can Bus I/O Voltage Range (CANH, CANL)	-42	42	V
V _(Logic_Input)	Logic Input Terminal Voltage Range (TXD, S)	-0.3	7	V
V _(Logic_Output)	Logic Output Terminal Voltage Range (RXD)	-0.3	7	V
I _{O_RXD}	Rxd (Receiver) Output Current	-8	8	mA
T _J	Maximum Junction Temperature	-40	150	°C
T _{STG}	Storage Temperature Range	-65	150	°C

(1) Stresses beyond those listed under Absolute Maximum Ratings may cause permanent damage to the device. Exposure to any Absolute Maximum Rating condition for extended periods may affect device reliability and lifetime.

(2) This data was taken with the JEDEC low effective thermal conductivity test board.

(3) This data was taken with the JEDEC standard multilayer test boards.

ESD(Electrostatic Discharge Protection)

Parameter		Condition	Minimum Level	Unit
IEC	IEC Contact Discharge	IEC-61000-4-2, Bus Pin	±15	kV
	IEC Air-Gap Discharge	IEC-61000-4-2, Bus Pin	±15	kV
HBM	Human Body Model ESD ⁽¹⁾	ANSI/ESDA/JEDEC JS-001, Bus Pin	±15	kV
		ANSI/ESDA/JEDEC JS-001, All Pin Except Bus Pin	±6	kV
CDM	Charged Device Model ESD ⁽²⁾	ANSI/ESDA/JEDEC JS-002, All Pin	±1.5	kV
LU	Latch up	Latch up per JESD78, All Pin	±500	mA

(1) JEDEC document JEP155 states that 500-V HBM allows safe manufacturing with a standard ESD control process.

(2) JEDEC document JEP157 states that 250-V CDM allows safe manufacturing with a standard ESD control process.

Fault Protected High-Speed CAN FD Transceiver with Silent Mode

Recommended Operating Conditions

	Parameter	Min	Max	Unit
V _{IO}	Input/output voltage, TXD, RXD,S of TPT1256	3.0	5.5	V
V _{CC}	Power Supply	4.5	5.5	V
I _{OH(RXD)}	RXD Terminal High-Level Output Current	-2	-	mA
I _{OL(RXD)}	RXD Terminal Low-Level Output Current	-	2	mA
T _A	Operating Ambient Temperature	-40	125	°C

Thermal Information

Package Type	θ_{JA}	θ_{JC}	Unit
SOP8	118	48	°C/W
DFN3x3-8	52	23	°C/W

Fault Protected High-Speed CAN FD Transceiver with Silent Mode
Electrical Characteristics

 All test conditions: $V_{CC} = 4.5\text{ V to }5.5\text{ V}$, $V_{IO} = 3.0\text{ V to }5.5\text{ V}$, $T_A = -40^\circ\text{C to }125^\circ\text{C}$, unless otherwise noted.

Parameter		Test Conditions	Min	Typ	Max	Unit
I _{CC}	Normal Mode (dominant)	TXD = 0 V, R _L = 60 Ω, C _L = open, R _{CM} = open, S = 0 V		50	70	mA
		TXD = 0 V, R _L = 50 Ω, C _L = open, R _{CM} = open, S = 0 V		52	80	mA
	Normal Mode (dominant – bus fault)	TXD = 0 V, S = 0 V, CANH = CANL = -3 /+18V, R _L = open, C _L = open, R _{CM} = open		73	150	mA
	Normal Mode (recessive)	TXD = V _{IO} , R _L = 50 Ω, C _L = open, R _{CM} = open, S = 0 V		1.2	2.5	mA
	Silent Mode	TXD = V _{IO} , R _L = 50 Ω, C _L = open, R _{CM} = open, S = V _{CC}		1.2	2.5	mA
I _{IO}	Normal and Silent Modes	RXD Floating, TXD = S = 0 or V _{IO}		73	200	μA
U _{VCC}	Rising Undervoltage Detection on V _{CC} for Protected Mode			4	4.4	V
	Falling Undervoltage Detection on V _{CC} for Protected Mode		3.6	3.9	4.2	
V _{HYS(UVCC)}	Hysteresis Voltage on U _{VCC} (1)			200		mV
U _{VIO}	Undervoltage Detection on V _{IO} for Protected Mode	V _{IH} and V _{IL}	1.3		2.75	V
V _{HYS(UVIO)}	Hysteresis Voltage on U _{VIO} for Protected Mode (1)			150		mV
Pin-S (mode select input)						
V _{IH}	High-level Input Voltage	TPT1256	0.7 x V _{IO}			V
		TPT1255	2			
V _{IL}	Low-level Input Voltage	TPT1256			0.3 x V _{IO}	V
		TPT1255			0.8	
I _{IH}	High-level Input Leakage Current	S = V _{CC} or V _{IO} = 5.5 V			30	μA
I _{IL}	Low-level Input Leakage Current	S = 0 V, V _{CC} = V _{IO} = 5.5 V	-1	0	1	
I _{Ikg(OFF)}	Unpowered Leakage Current	S = 5.5 V, V _{CC} = V _{IO} = 0 V	-1	0	1	
Pin-TXD (CAN transmit data input)						
V _{IH}	High-level Input Voltage	TPT1256	0.7 x V _{IO}			V
		TPT1255	2			

Fault Protected High-Speed CAN FD Transceiver with Silent Mode

Parameter		Test Conditions	Min	Typ	Max	Unit	
V _{IL}	Low-level Input Voltage	TPT1256			0.3 x V _{IO}		
		TPT1255			0.8		
I _{IH}	High-level Input Leakage Current	S = V _{CC} or V _{IO} = 5.5 V	-2.5	0	1	μA	
I _{IL}	Low-level Input Leakage Current	S = 0 V, V _{CC} = V _{IO} = 5.5 V	-100	-63	-7		
I _{Ikg(OFF)}	Unpowered Leakage Current	TXD = 5.5 V, V _{CC} = V _{IO} = 0 V	-1	0	1		
C _I	Input Capacitance ⁽¹⁾			5		pF	
Pin- RXD (CAN Receive data output)							
V _{OH}	High-level Output Voltage	TPT1256, I _O = -2 mA	0.8 x V _{IO}			V	
		TPT1255, I _O = -2 mA	4	4.6			
V _{OL}	Low-level Output Voltage	TPT1256, I _O = +2 mA			0.2 x V _{IO}	V	
		TPT1255, I _O = +2 mA		0.2	0.4		
I _{Ikg(OFF)}	Unpowered Leakage Current	RXD = 5.5 V, V _{CC} = 0 V, V _{IO} = 0 V	-1	0	1	μA	
Driver Electrical Characteristics							
V _{O(DOM)}	Bus Output Voltage (dominant)	CANH	TXD = 0 V, S = 0 V, 45 Ω	2.75		4.5	V
		CANL	≤ R _L ≤ 65 Ω, C _L = open, R _{CM} = open	0.5		2.25	V
V _{O(REC)}	Bus Output Voltage (recessive)	CANH CANL	TXD = V _{CC} , V _{IO} = V _{CC} , S = V _{CC} or 0 V ⁽²⁾ , R _L = open (no load), R _{CM} = open	2	0.5 x V _{CC}	3	V
V _{OD(DOM)}	Differential Output Voltage (dominant)	CANH CANL	TXD = 0 V, S = 0 V, 45 Ω	1.4		3	V
			≤ R _L < 50 Ω, C _L = open, R _{CM} = open				
			TXD = 0 V, S = 0 V, 50 Ω	1.5		3	V
			≤ R _L ≤ 65 Ω, C _L = open, R _{CM} = open				
			TXD = 0 V, S = 0 V, R _L = 2240 Ω, C _L = open, R _{CM} = open, V _{CC} = 4.5 V~5.25 V	1.5		5	V
V _{OD(REC)}	V _{OD(REC)}	V _{OD(REC)}	TXD = V _{CC} , S = 0 V, R _L = 60 Ω, C _L = open, R _{CM} = open	-120		12	mV
			TXD = V _{CC} , S = 0 V, R _L = open (no load), C _L = open, R _{CM} = open	-50		50	mV
V _{SYM}	Transient Symmetry (dominant or recessive), (V _{O(CANH)} + V _{O(CANL)}) / V _{CC} ⁽²⁾		S at 0 V, R _{term} = 60 Ω, C _{split} = 4.7 nF, C _L = open, R _{CM} = open, T _{XD} = 250 kHz, 1 MHz		1		V/V

Fault Protected High-Speed CAN FD Transceiver with Silent Mode

Parameter		Test Conditions	Min	Typ	Max	Unit
V_{SYM_DC}	DC Output Symmetry (dominant or recessive), $(V_{CC} - V_{O(CANH)} - V_{O(CANL)})^{(2)}$	$S = 0\text{ V}$, $R_L = 60\ \Omega$, $C_L = \text{open}$, $R_{CM} = \text{open}$	-0.4		0.4	V
$I_{OS(SS_DOM)}$	Short-circuit Steady-State Output Current, dominant	S at 0 V , $V_{CANH} = -5\text{ V to }40\text{ V}$, $CANL = \text{open}$, $TXD = 0\text{ V}$	-100			mA
		S at 0 V , $V_{CANL} = -5\text{ V to }40\text{ V}$, $CANH = \text{open}$, $TXD = 0\text{ V}$			100	
$I_{OS(SS_REC)}$	Short-circuit Steady-State Output Current, recessive	$-27\text{ V} \leq V_{BUS} \leq 32\text{ V}$, Where $V_{BUS} = CANH = CANL$, $TXD = V_{CC}$	-5		5	mA
Receiver Electrical Characteristics						
V_{CM}	Common Mode Range, normal mode	$S = 0$ or V_{CC} or V_{IO}	-30		30	V
V_{IT+}	Positive-going Input Threshold Voltage, all modes	$S = 0$ or V_{CC} or V_{IO} ,			900	mV
V_{IT-}	Negative-going Input Threshold Voltage, all modes	$-20\text{ V} \leq V_{CM} \leq +20\text{ V}$	500			
V_{IT+}	Positive-going Input Threshold Voltage, all modes	$S = 0$ or V_{CC} or V_{IO} ,			1000	mV
V_{IT-}	Negative-going Input Threshold Voltage, all modes	$-30\text{ V} \leq V_{CM} \leq +30\text{ V}$	400			
V_{HYS}	Hysteresis Voltage ($V_{IT+} - V_{IT-}$) ⁽¹⁾	$S = 0$ or V_{CC} or V_{IO}		120		mV
$I_{lkg(IOFF)}$	Power-off (unpowered) Bus Input Leakage Current	$CANH = CANL = 5\text{ V}$, $V_{CC} = V_{IO} = 0\text{ V}$			3	μA
C_i	Input Capacitance to Ground (CANH or CANL) ⁽¹⁾			25		pF
C_{ID}	Differential Input Capacitance ⁽¹⁾			2		pF
R_{ID}	Differential Input Resistance	$TXD = V_{CC} = V_{IO} = 5\text{ V}$,	30		80	k Ω
R_{IN}	Input Resistance (CANH or CANL)	$S = 0\text{ V}$, $-30\text{ V} \leq V_{CM} \leq +30\text{ V}$	15		40	k Ω
$R_{IN(M)}$	Input Resistance Matching:	$V_{CANH} = V_{CANL} = 5\text{ V}$	-1%		1%	
	$[1 - R_{IN(CANH)} / R_{IN(CANL)}] \times 100\%$					

(1) The Test data is based on bench test and design simulation.

(2) Test data based on bench test and design simulation, $V_{sym} = 0.9 \sim 1.1\text{ V/V}$ at 250 kbps

Fault Protected High-Speed CAN FD Transceiver with Silent Mode
AC Timing Requirements

 All test conditions: $V_{CC} = 4.5\text{ V to }5.5\text{ V}$, $V_{IO} = 3.0\text{ V to }5.5\text{ V}$, $T_A = -40^\circ\text{C to }125^\circ\text{C}$, unless otherwise noted.

Parameter		Test Conditions	Min	Typ	Max	Unit
Device Switching Characteristics						
$t_{PROP(LOOP1)}$	Total loop delay, driver input (TXD) to receiver output (RXD), recessive to dominant	$S = 0\text{ V}$, $R_L = 60\ \Omega$, $C_L = 100\text{ pF}$, $C_{L(RXD)} = 15\text{ pF}$	-	100	160	ns
$t_{PROP(LOOP2)}$	Total loop delay, driver input (TXD) to receiver output (RXD), dominant to recessive		-	110	175	
t_{MODE}	Mode change time, from Normal to Silent or from Silent to Normal		-	0.15	10	μs
Driver Switching Characteristics						
t_{pHR}	Propagation delay time, high TXD to driver recessive (dominant to recessive) ⁽¹⁾	$S = 0\text{ V}$, $R_L = 60\ \Omega$, $C_L = 100\text{ pF}$, $R_{CM} = \text{open}$	-	70	-	ns
t_{pLD}	Propagation delay time, low TXD to driver dominant (recessive to dominant) ⁽¹⁾		-	40	-	
$t_{sk(p)}$	Pulse skew ($ t_{pHR} - t_{pLD} $) ⁽¹⁾		-	20	-	
t_R	Differential output signal rise time ⁽¹⁾		-	27	-	
t_F	Differential output signal fall time ⁽¹⁾		-	35	-	
t_{TXD_DTO}	Dominant timeout	$S = 0\text{ V}$, $R_L = 60\ \Omega$, $C_L = \text{open}$	1.2		3.8	ms
Receiver Switching Characteristics						
t_{pRH}	Propagation delay time, bus recessive input to high output (Dominant to Recessive) ⁽¹⁾	$S = 0\text{ V}$, $C_{L(RXD)} = 15\text{ pF}$	-	76	-	ns
t_{pDL}	Propagation delay time, bus dominant input to low output (Recessive to Dominant) ⁽¹⁾		-	59	-	
t_R	RXD Output signal rise time ⁽¹⁾		-	12	-	
t_F	RXD Output signal fall time ⁽¹⁾		-	7	-	
FD Timing Parameters						
$t_{BIT(BUS)}$	Bit time on CAN bus output pins with $t_{BIT(TXD)} = 500\text{ ns}$, all devices	$S = 0\text{ V}$, $R_L = 60\ \Omega$, $C_L = 100\text{ pF}$, $C_{L(RXD)} = 15\text{ pF}$, $\Delta t_{REC} = t_{BIT(RXD)} - t_{BIT(BUS)}$	435	-	530	ns
	Bit time on CAN bus output pins with $t_{BIT(TXD)} = 200\text{ ns}$, G device variants only		155	-	210	

Fault Protected High-Speed CAN FD Transceiver with Silent Mode

Parameter		Test Conditions	Min	Typ	Max	Unit
t _{BIT(RXD)}	Bit time on RXD output pins with t _{BIT(TXD)} = 500 ns, all devices		400	-	550	
	Bit time on RXD output pins with t _{BIT(TXD)} = 200 ns, G device variants only		120	-	220	
Δt _{REC}	Receiver timing symmetry with t _{BIT(TXD)} = 500 ns, all devices		-65	-	40	
	Receiver timing symmetry with t _{BIT(TXD)} = 200 ns, G device variants only		-45	-	15	

(1) The test data is based on bench test and design simulation.

Detailed Description

Overview

The TPT125x device is a CAN transceiver that meets the ISO11898 High-speed CAN (Controller Area Network) physical layer standard. The device is designed to be used in CAN FD networks up to 5 Mbps, and to enhance timing margin and higher data rates in long and high-loading networks. As designed, the device features cross-wire, overvoltage, and loss of ground protection from -42 V to +42 V, overtemperature shutdown, and a -30 V to +30 V common-mode range. The TPT1256 has a secondary power supply input for I/O level shifting the input pin thresholds and RXD output level. The device comes with a silent mode which is also commonly referred to as listen-only mode, and it includes many protection features to enhance device and network robustness.

Functional Block Diagram

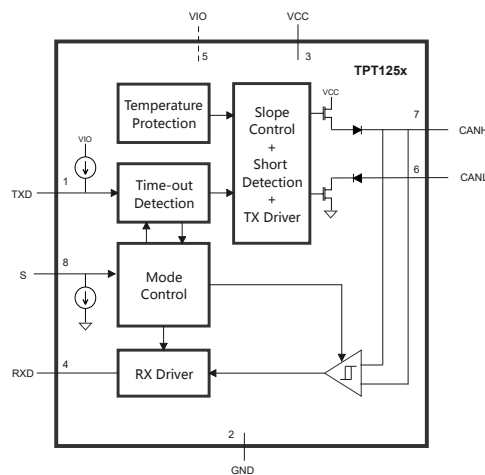

Figure 1. Functional Block Diagram

Feature Description

Under-voltage Lockout (UVLO)

The TPT1256 uses an under-voltage lockout circuit to keep the device in shutdown mode until the supply voltage is higher than the UVLO threshold.

Over Temperature Protection (OTP)

The TPT125x integrates foldback circuit and over-temperature protection to prevent device from over-heated and damage. When the junction temperature is higher than T_{OTP} , 150°C, a current thermal foldback circuit starts to work and decrease the device output charge current gradually with T_J rise. If T_J still rises and reaches 180°C, the device will shut down charging loop until T_J drops below 100°C.

Time-out Function in TXD Dominant Mode

When the TXD pin is set to low, the timer of 'TXD dominant time-out' is started. If the low state on TXD persists for longer than t_{TXD_DTO} , the transmitter is disabled and the bus lines are in recessive state. This function prevents a hardware

Fault Protected High-Speed CAN FD Transceiver with Silent Mode

and/or software application failure from driving the bus lines to a permanent dominant state which will block all network communications. The TXD dominant time-out timer is reset as TXD is pulled to high.

Over-Temperature Protection (OTP)

The output drivers are protected against over-temperature conditions. If the virtual junction temperature exceeds the shutdown junction temperature T_{OTP} , the output drivers will be disabled until the virtual junction temperature falls below T_{OTP} and TXD becomes recessive again. Including the TXD condition to ensures output driver oscillation due to temperature drift is avoided.

Table 3. Driver Function Table

Device	Inputs		Outputs		Driven BUS State
	S	TXD	CANH	CANL	
All Devices	L or open	L	H	L	Dominant
		H or Open	Z	Z	Recessive
	H	X	Z	Z	Recessive

Table 4. Receiver Function Table

Device Mode	CAN Differential Inputs V_{ID} $= V_{CANH} - V_{CANL}$	Bus State	RXD Terminal
Normal or Silent	$V_{ID} \geq V_{IT+(MAX)}$	Dominant	L
	$V_{IT-(MIN)} < V_{ID} < V_{IT+(MAX)}$	Indeterminate	Indeterminate
	$V_{ID} \leq V_{IT-(MIN)}$	Recessive	H
	Open ($V_{ID} \approx 0 V$)	Open	H

Normal Mode

A low level on the S pin selects the normal mode. In this mode, the transceiver will transmit and receive data via the bus lines CANH and CANL. The differential receiver converts the analog data on the bus lines into digital data, which is output to the RXD pin. The slopes of the output signals on the bus lines are controlled internally and optimized to guarantee the lowest possibility for Electro Magnetic Emission (EME).

Silent Mode

A high level on the S pin selects the silent mode. In the silent mode, the transmitter is disabled, releasing the bus pins to the recessive state. All other IC functions, including the receiver, continue to operate as in the normal mode, just like the listen-only mode. Silent mode can be used to prevent a faulty CAN controller from disrupting all network communications.

Application and Implementation

Note

Information in the following application sections is not part of the 3PEAK's component specification and 3PEAK does not warrant its accuracy or completeness. 3PEAK's customers are responsible for determining suitability of components for their purposes. Customers should validate and test their design implementation to confirm system functionality.

Application Information

The TPT1256 device is a CAN transceiver to support CAN FD function up to 5 Mbps, with BUS protection voltage from -42 V to +42 V, overtemperature shutdown, and a -30 V to +30 V common-mode range. The VIO of TPT1256 can support the voltage level of TXD and RXD from 3.3 V to 5.0 V, and the pin 5 of TPT1255 is NC which means it can only support 5-V I/O voltage.

The following sections show typical applications of the TPT1256 and TPT1255.

Typical Application

Figure 2 shows the typical application schematic of the TPT125x.

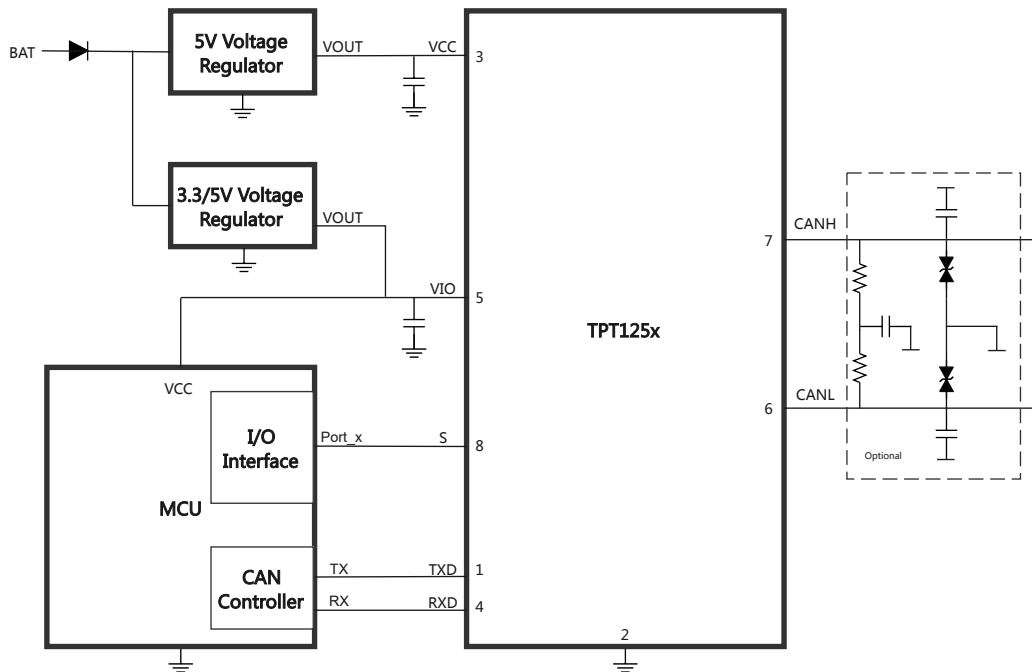
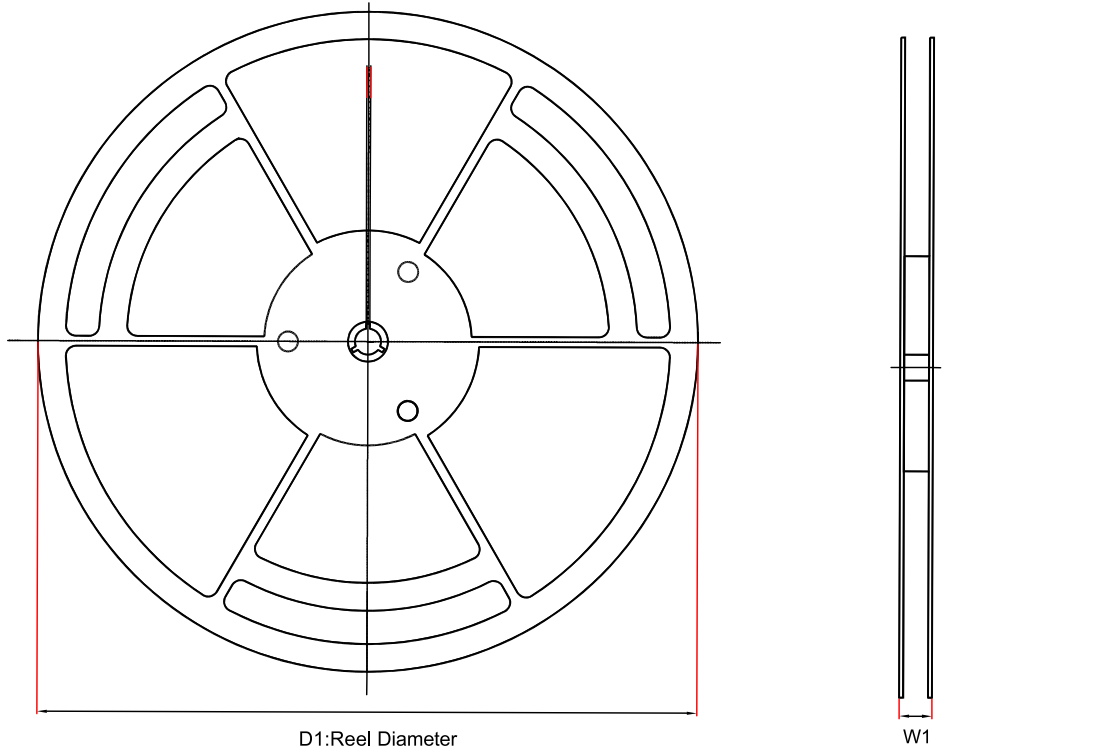

Figure 2. Typical Application Circuit

Tape and Reel Information



Order Number	Package	D1 (mm)	W1 (mm)	A0 (mm)	B0 (mm)	K0 (mm)	P0 (mm)	W0 (mm)	Pin1 Quadrant
TPT1255-SO1R	SOP8	330.0	17.6	6.4	5.4	2.1	8.0	12.0	Q1
TPT1256-SO1R	SOP8	330.0	17.6	6.4	5.4	2.1	8.0	12.0	Q1
TPT1255-DF6R	DFN3X3-8	330.0	17.6	3.3	3.3	1.1	8.0	12.0	Q1
TPT1256-DF6R	DFN3X3-8	330.0	17.6	3.3	3.3	1.1	8.0	12.0	Q1

Package Outline Dimensions

SOP8

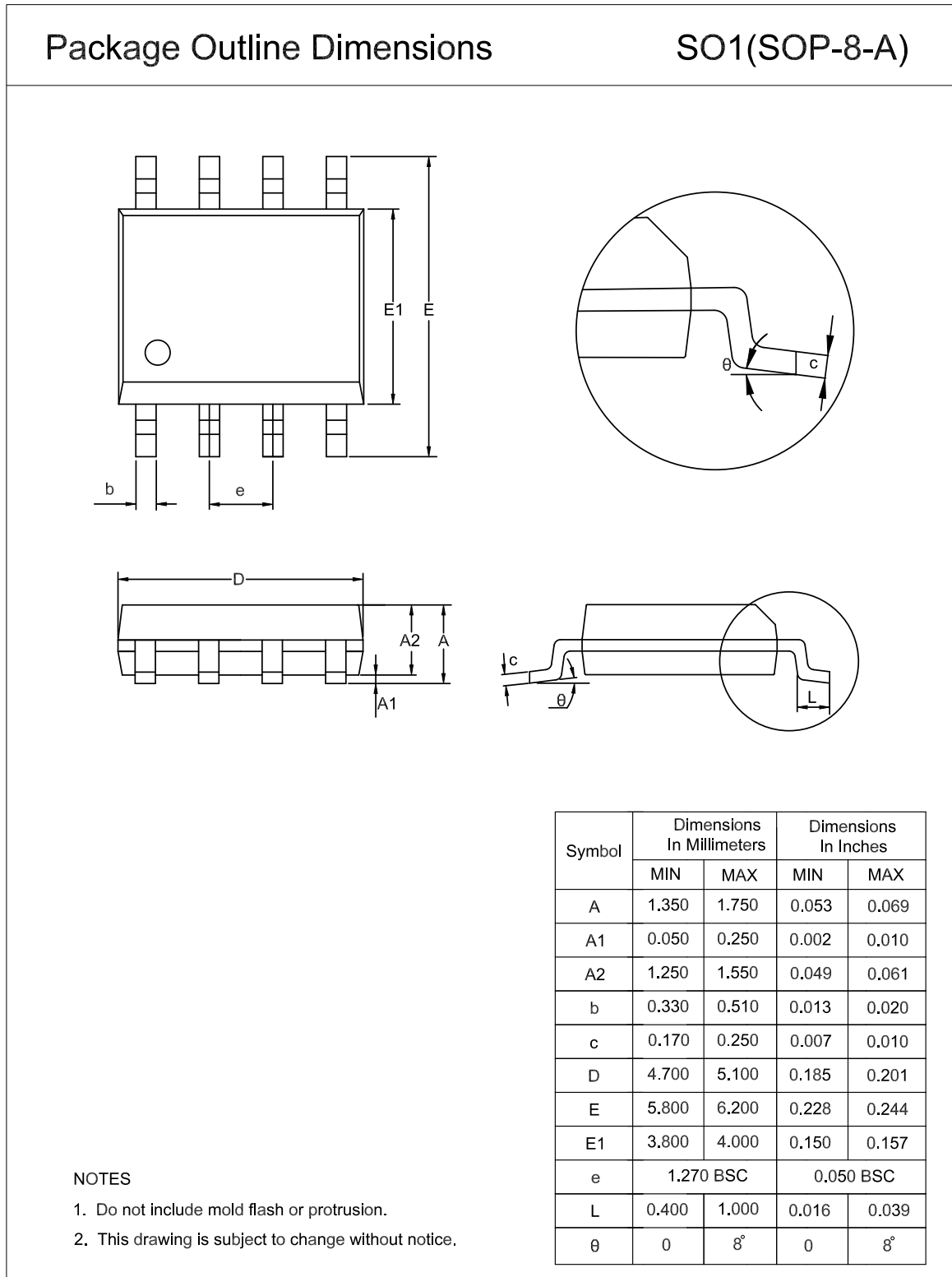

DFN3X3-8

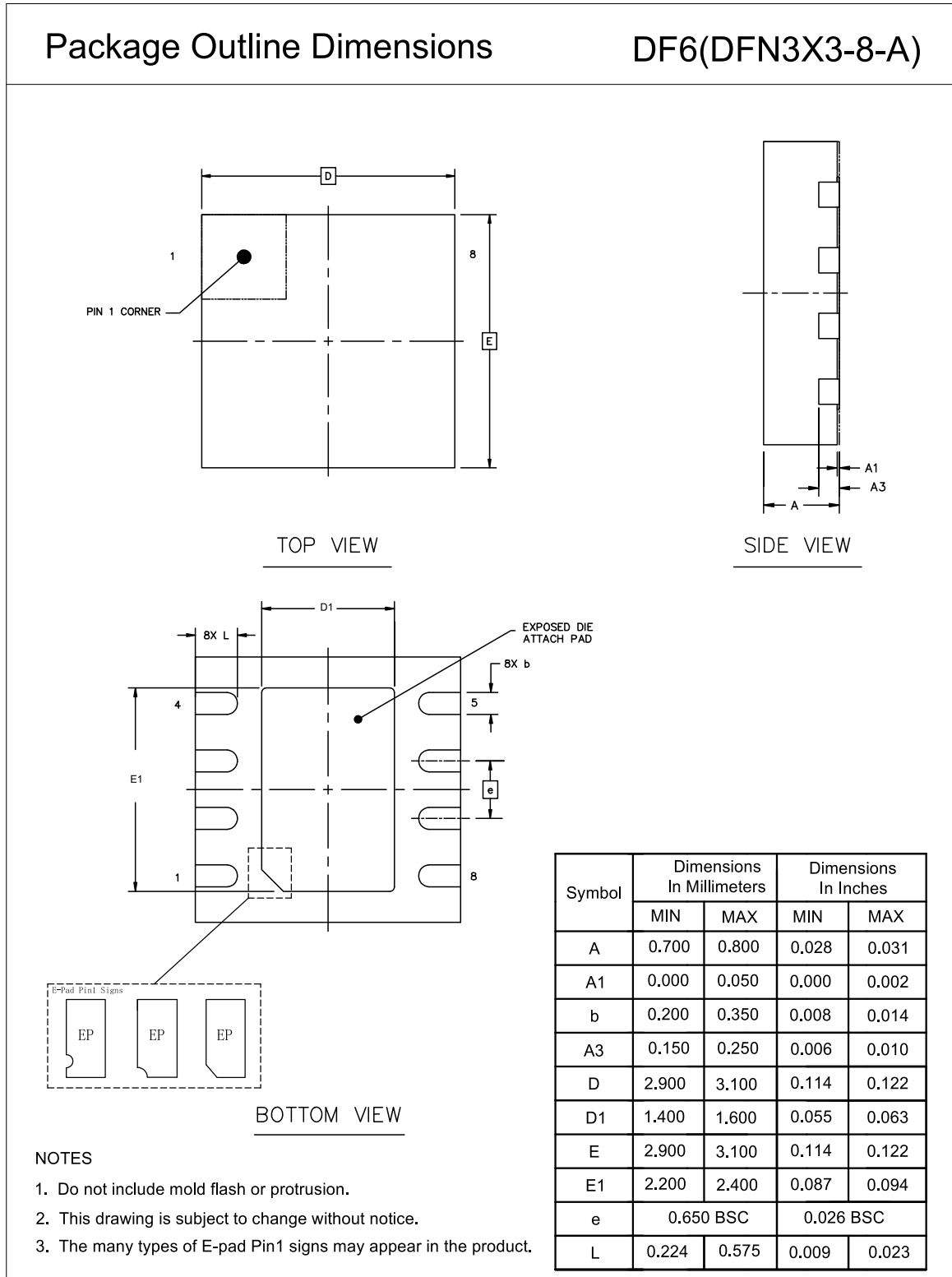

Order Information

Order Number	Operating Temperature Range	Package	Marking Information	MSL	Transport Media, Quantity	Eco Plan
TPT1255-SO1R	-40 to 125°C	SOP8	T1255	MSL3	Tape and Reel, 4000	Green
TPT1256-SO1R	-40 to 125°C	SOP8	T1256	MSL3	Tape and Reel, 4000	Green
TPT1255-DF6R	-40 to 125°C	DFN8	1255	MSL3	Tape and Reel, 4000	Green
TPT1256-DF6R	-40 to 125°C	DFN8	1256	MSL3	Tape and Reel, 4000	Green

Green: 3PEAK defines "Green" to mean RoHS compatible and free of halogen substances.

IMPORTANT NOTICE AND DISCLAIMER

Copyright© 3PEAK 2012-2023. All rights reserved.

Trademarks. Any of the 思瑞浦 or 3PEAK trade names, trademarks, graphic marks, and domain names contained in this document /material are the property of 3PEAK. You may NOT reproduce, modify, publish, transmit or distribute any Trademark without the prior written consent of 3PEAK.

Performance Information. Performance tests or performance range contained in this document/material are either results of design simulation or actual tests conducted under designated testing environment. Any variation in testing environment or simulation environment, including but not limited to testing method, testing process or testing temperature, may affect actual performance of the product.

Disclaimer. 3PEAK provides technical and reliability data (including data sheets), design resources (including reference designs), application or other design recommendations, networking tools, security information and other resources "As Is". 3PEAK makes no warranty as to the absence of defects, and makes no warranties of any kind, express or implied, including without limitation, implied warranties as to merchantability, fitness for a particular purpose or non-infringement of any third-party's intellectual property rights. Unless otherwise specified in writing, products supplied by 3PEAK are not designed to be used in any life-threatening scenarios, including critical medical applications, automotive safety-critical systems, aviation, aerospace, or any situations where failure could result in bodily harm, loss of life, or significant property damage. 3PEAK disclaims all liability for any such unauthorized use.