



# Simple Packaged Crystal Oscillator

## ■ NP3225SB Data Sheet (Differential Output SPXO)

### Main Application

- For Automotive CCD camera, Image processing, Memory, FPGA, Ground equipment for satellite communication and Digital terrestrial television broadcasting equipment
- For Car audio, In-vehicle computer

### Features

- Output Specification: LVDS
- Compact dimension: 3.2 × 2.5 × 0.9 mm
- Supply Voltage: +2.5 V or +3.3 V
- Excellent low Phase Jitter (Typ. 100 fs @156.25 MHz)
- Automatic mounting by taping and IR reflow (lead-free) are possible.
- Lead-free.
- Conforms to AEC-Q200

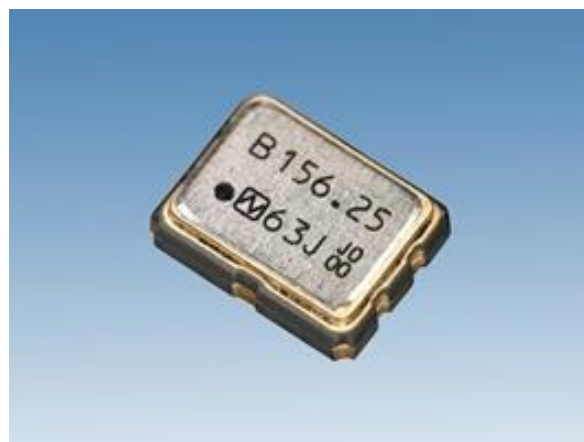

**RoHS Compliant**  
Directive 2011/65/EU  
Directive (EU) 2015/863

**Pb free**

**AEC-Q200**

1. Item : Simple Packaged Crystal Oscillator
2. Type : NP3225SB
3. Nominal Frequency : 100 to 220 MHz
4. NDK Spec. No. : See Table.1

## 5. Maximum Ratings

	Item	Ratings			Notes
		min	max	Units	
1	Supply Voltage	-0.3	+4.0	V	
2	Input Voltage	-0.3	$V_{CC}+0.3$	V	
3	Storage Temperature Range	-55	+125	°C	

## 6. Electrical Specifications

	Parameters	SYM	Electrical Spec.				Notes
			min	typ	max	Units	
1	Nominal Frequency	$f_{nom}$	100		220	MHz	See Table.2
2	Supply Voltage	$V_{CC}$	+2.5 to +3.3			V	See Table.1
3	Current Consumption (Operating)	$I_{CC}$			40	mA	at 25 °C
4	Current Consumption (Stand-by)	$I_{ST}$	See Table.1			μA	at 25 °C
5	Output Level	-	LVDS				
6	Load	$R_L$		100		Ω	Out-Complementary Out
7	Operating Temperature Range	$T_{opr}$	[-40 to +85] to [-40 to +105]			°C	See Table.1
8	Overall Frequency Tolerance	$\Delta f/f_{nom}$	-50		+50	ppm	*1
9	Differential Output Voltage	$V_{OD}$	+0.247		+0.454	V	
		$\Delta V_{OD}$			50	mV	
10	Offset Voltage	$V_{OS}$	1.125		1.375	V	
		$\Delta V_{OS}$			50	mV	
11	Rise Time( $t_r$ ), Fall Time( $t_f$ )	$t_r/t_f$			0.4	ns	20 % to 80 % waveform
12	Symmetry	SYM	45		55	%	at 50 % Waveform
13	Start-up Time	$t_{su}$			10	ms	
14	Phase Jitter	$t_{pj}$			1	ps	*2
15	Output Wave Form	-	Square wave				
16	Stand-by Function	#1 PAD input			#4, 5 PAD output		
		H level (0.7 $V_{CC}$ to $V_{CC}$ ) or open			Operating		
		L level (0.3 $V_{CC}$ max)			High impedance		

\*1 Inclusive of Freq. tolerance (at 25 °C), frequency/temperature characteristics, frequency/voltage coefficient.

\*2 Measured by Agilent E5052A. Offset frequency 12 kHz to 20 MHz, at 25 °C

Table.1 NDK Spec. No. List

Nominal Frequency	Operating Temperature Range [°C]	Current Consumption (Stand-by)	Supply Voltage [V]	
			2.5 V±5 %	3.3 V±10 %
100 to 175 MHz	-40 to +85	15 $\mu$ A MAX.	NSC5343A	NSC5343B
	-40 to +105	30 $\mu$ A MAX.	NSC5344A	NSC5344B
175 to 220 MHz	-40 to +85	15 $\mu$ A MAX.	NSC5236A	NSC5236B
	-40 to +105	30 $\mu$ A MAX.	NSC5238A	NSC5238B

Table.2 Supported Frequency List

Nominal Frequency [MHz]	NDK Spec.							
	NSC5343A	NSC5343B	NSC5344A	NSC5344B	NSC5236A	NSC5236B	NSC5238A	NSC5238B
100	●	●	●	●	-	-	-	-
125	●	●	●	●	-	-	-	-
135	●	●	●	●	-	-	-	-
148	●	●	●	●	-	-	-	-
156.25	●	●	●	●	-	-	-	-
200	-	-	-	-	●	●	●	●

● is supported frequency.

Frequencies not listed in the list are also available, so please contact us if you have any request.

Output Voltage

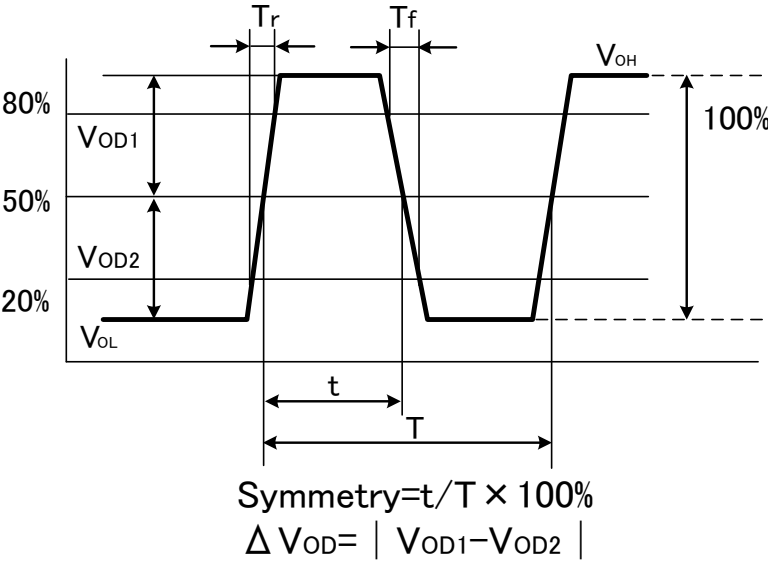

Waveform(Single end)

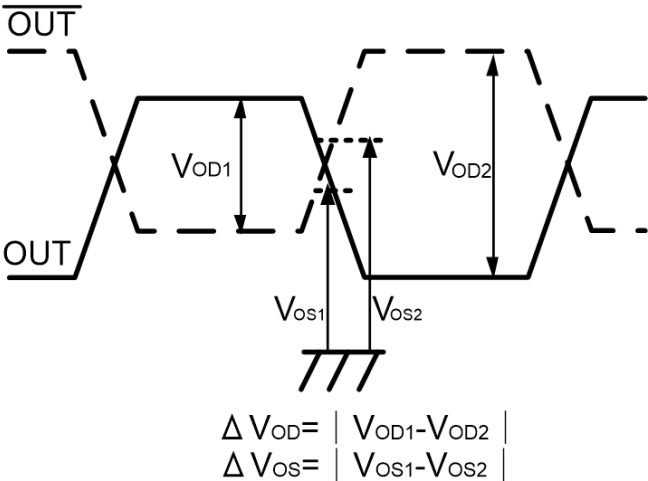

# Start-up Time

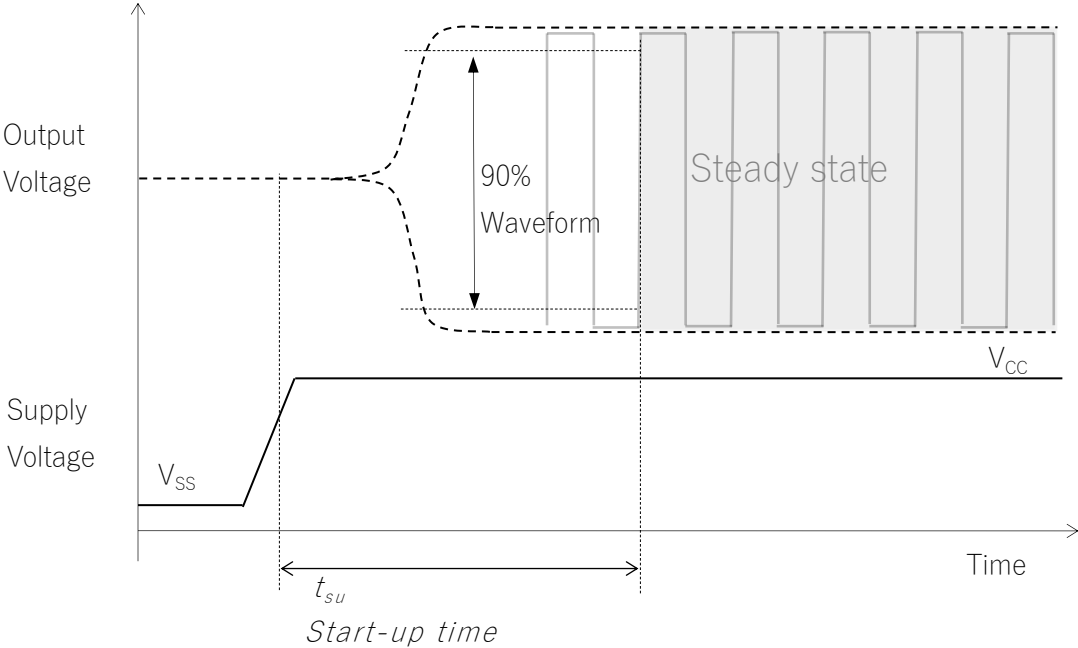

Measuring circuits

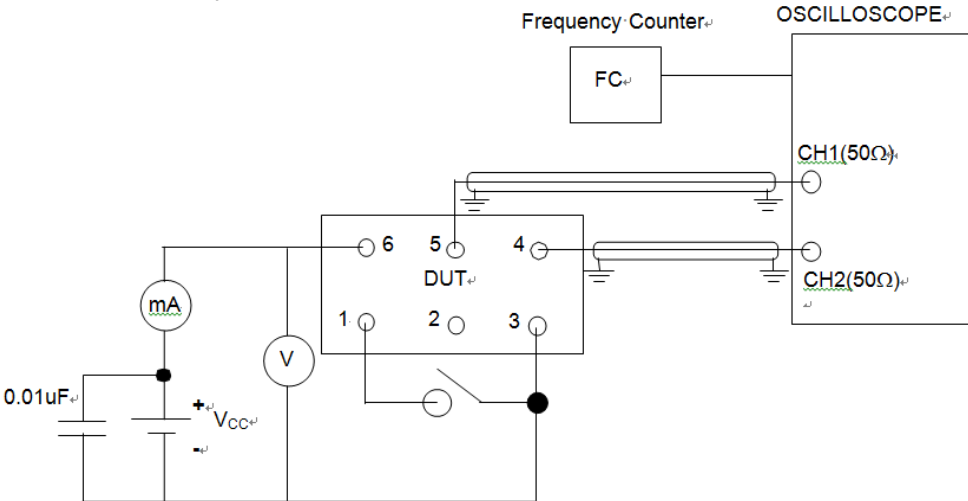

## 7. Prohibited items

Example For Soldering Conditions (The below graph corresponds to Pb free solder)

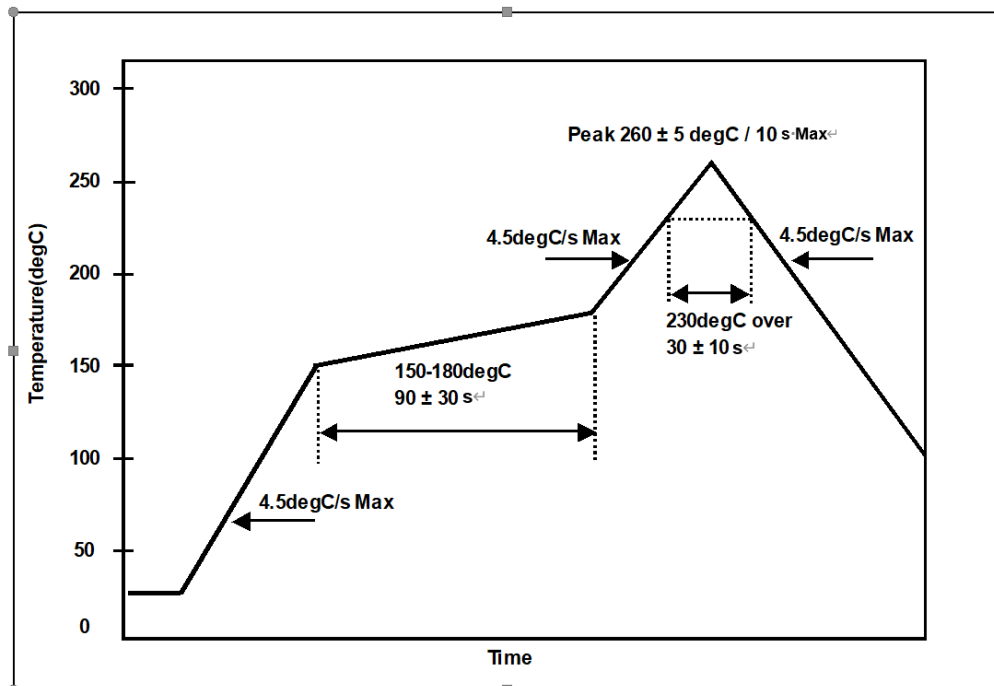

Be sure to use the product under the following conditions. Otherwise, the characteristics deterioration or destruction of the product may result.

- (1) Reflow soldering heat resistance
  - Peak temperature: 265 °C, 10 s
  - Heating: 230 °C or higher, 40 s
  - Preheating: 150 °C to 180 °C, 120 s
  - Reflow passage times: 3 times
- (2) Manual soldering heat resistance
  - Pressing a soldering iron of 350 °C on the terminal electrode for 3 s.

## 8. Electrostatic Discharge

MM: 200 V  
 HBM: 2000 V  
 CDM: 500 V

■Dimension of External

Unit : mm

Tolerance : ±0.1

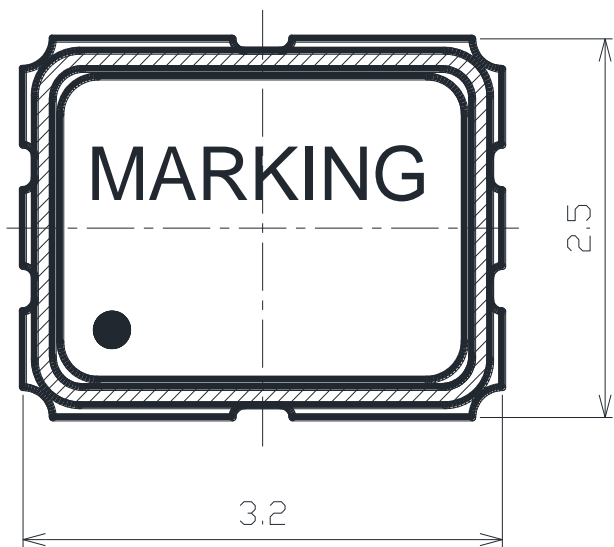

Terminal land connections

#1	Stand-by
#2	NC
#3	GND
#4	OUT
#5	OUT
#6	V <sub>CC</sub>

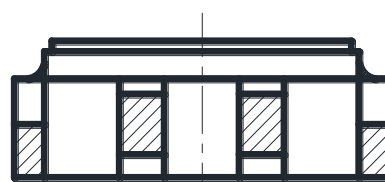
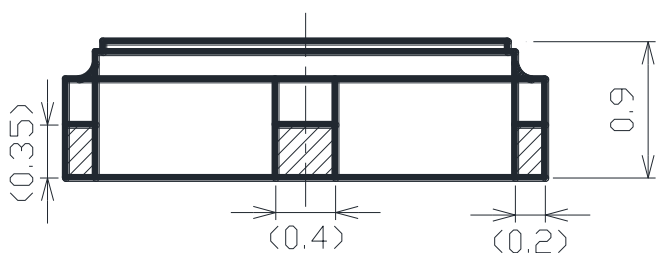

Land pattern (Recommended)

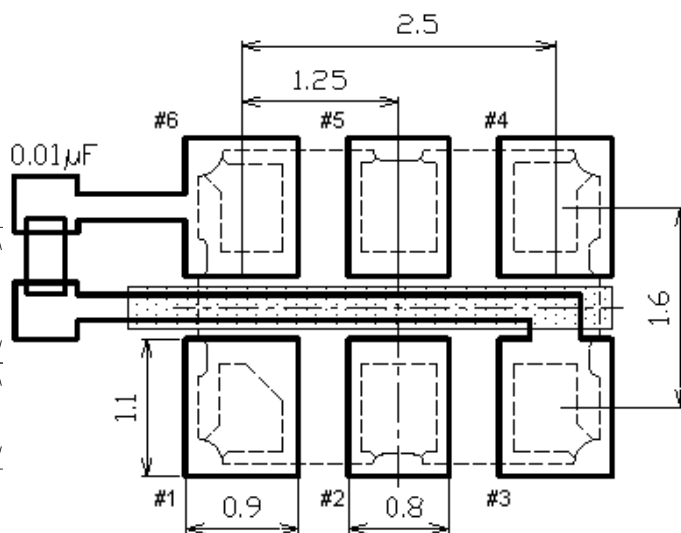
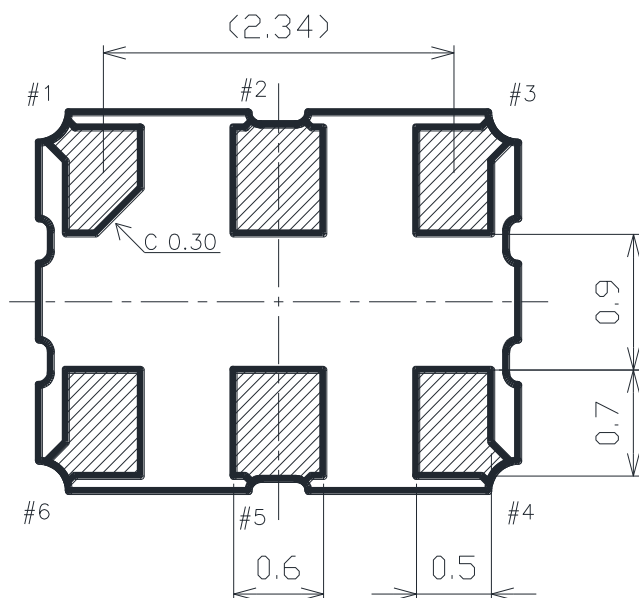



■ Taping and Reel Spec. (1/2)

Unit : mm

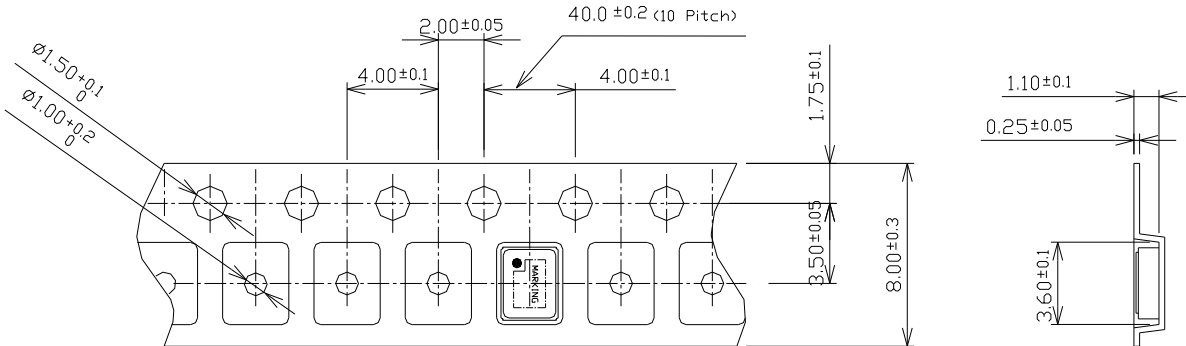

	Embossed carrier tape	Top cover tape
Materials	PS	PET + PE + Adhesive layer
Disposition	Antistatic	Antistatic

■Taping and Reel Spec. (2/2)

Unit : mm

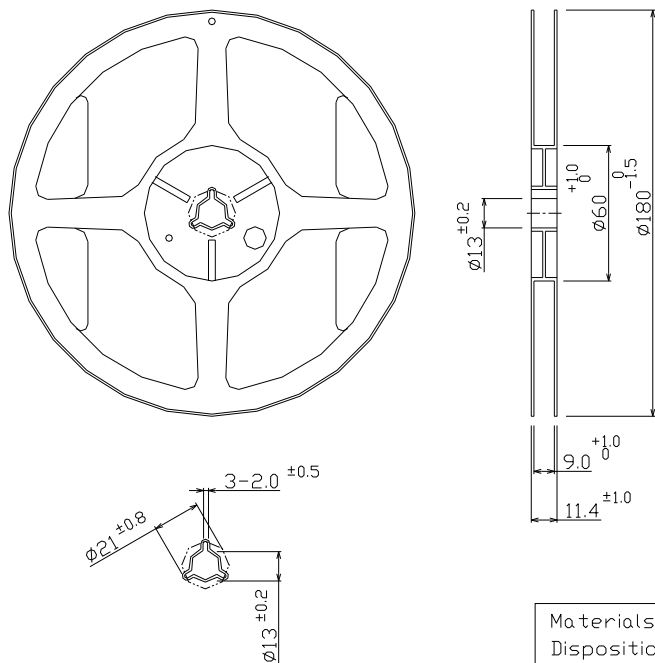

Materials : PS  
Disposition : Antistatic

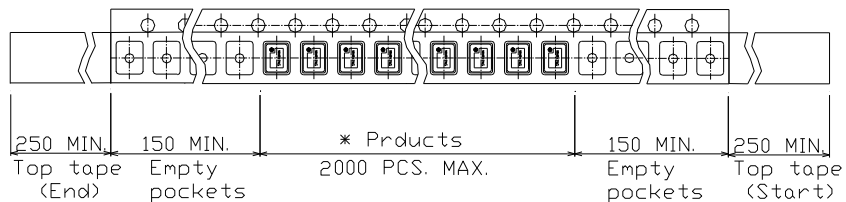

\* There are no vacant pockets for this area.

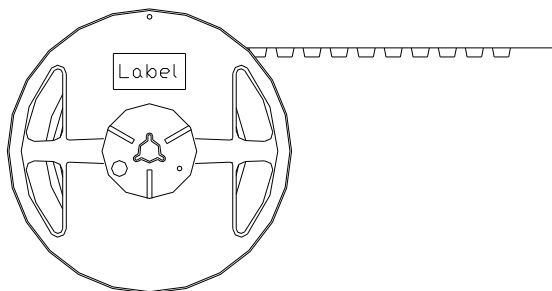

## ■Marking

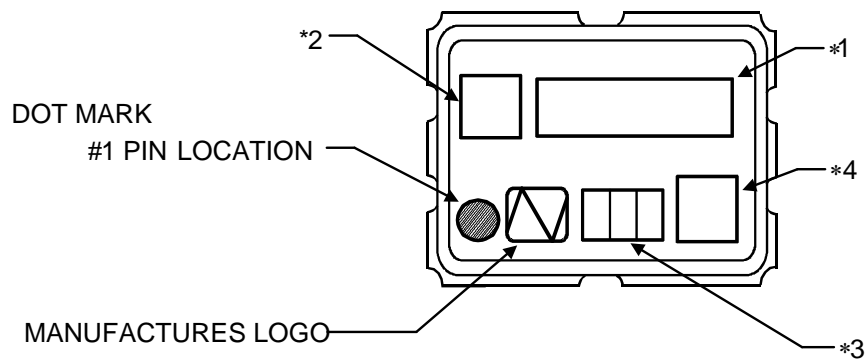

\*1 [FREQUENCY]

\*2 [MODEL MARK]  
NP3225SB → B

\*3 [WEEK CODE (Digit are three)]

\*4 [Trace code]

■Data

- Phase noise

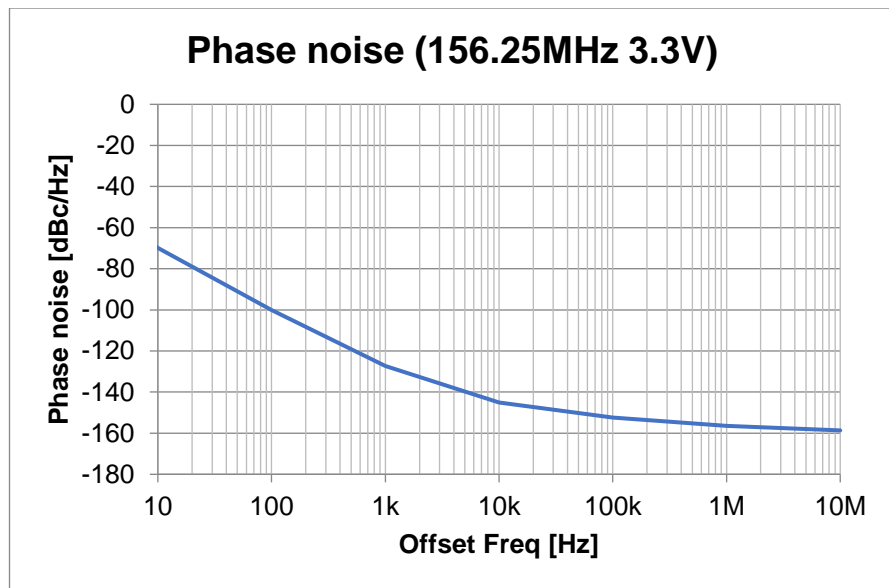

- Phase jitter : Typ. 100 fs (Offset frequency : 12 kHz to 20 MHz)@156.25 MHz, 3.3 V

## Instruction Notice

### 1 Noise

When using this product, please insert a bypass capacitor between the power supply and GND.  
(Closer to the product terminal is desirable.)

The bypass capacitor values shown in our specifications and drawings are for reference only.  
(They are not guaranteed values.)

In actual use, please select the appropriate bypass capacitor value for your circuit.

NDK shall not be liable for any and all events resulting from or in connection with the use of this product in a manner that does not comply with the above instruction.

### 2 Resistance to dropping

The NP3225S series is designed to be impactproof so that no damage occurs when dropped a height (75 cm) three times. However, if dropped from a desk etc., it is advisable to check their performance or contact us to check it.

### 3 Electrostatic protection

The NP3225S series employ C-MOS ICs for the active element. Please use them in static-free environments.

### 4 High temperature

Normal operation cannot be guaranteed for the NP3225S series at +125 °C (for 24 h). Be sure that the units are kept within the specified temperature range.

### 5 Cleaning

Basically, the NP3225S series are applicable for ultrasonic wave cleaning. However, in some case, during ultrasonic wave cleanings, internal design may get damage. Please check condition carefully beforehand.

### 6 Other

The NP3225S series are C-MOS applied products. And careful handling (same as with C-MOS IC) are needed to avoid electrostatic problems.

Incorrect PAD connection is cause of trouble. Please make sure to connect correctly as below.

#3 terminal → GND

#6 terminal → V<sub>CC</sub>

## Notes On Use

1 Even if the appearance color etc. of the product differs by purchasing the component parts by more than two companies, there is no influence on the characteristics and reliability.

2 IN THE CASE OF THE FOLLOWING ITEMS, WE ARE NOT RESPONSIBLE FOR WARRANTY / COMPENSATION.

(1) WHEN PRODUCTS OF THIS SPECIFICATION ARE USED FOR EQUIPMENT RELATED TO HUMAN LIFE OR PROPERTY, IT IS THE RESPONSIBILITY OF THE CUSTOMER TO CONFIRM THE INFLUENCE ON THIS PRODUCT AND EQUIPMENT TO BE USED BEFOREHAND, CONDUCT NECESSARY SAFETY DESIGN (INCLUDING REDUNDANT DESIGN, MALFUNCTION PREVENTION DESIGN, etc.), PLEASE USE IT AFTER SECURING SUFFICIENT SAFETY OF EQUIPMENT.

1.SAFETY-RELATED EQUIPMENT SUCH AS AUTOMOBILES, TRAINS, SHIPS, etc., OR EQUIPMENT DIRECTLY INVOLVED IN OPERATION

2.AIRCRAFT EQUIPMENT

3.SPACE EQUIPMENT

4.MEDICAL EQUIPMENT

5.MILITARY EQUIPMENT

6.DISASTER PREVENTION / CRIME PREVENTION EQUIPMENT

7.TRAFFIC LIGHT

8.OTHER EQUIPMENT REQUIRING THE SAME PERFORMANCE AS THE ABOVE-MENTIONED EQUIPMENT

(2) IN CASES WHERE IT IS NOT INDICATED IN THE REQUESTED STANDARD AND IS USED UNDER CONDITIONS OF USE (INCLUDING CIRCUIT MARGIN etc.) THAT CAN NOT BE PREDICTED AT THE PRODUCTION STAGE.

(3) WHEN USING ULTRASONIC WELDING MACHINE.(THERE IS A POSSIBILITY THAT THE CHARACTERISTIC DEGRADATION IS CAUSED BY THE RESONANCE PHENOMENON OF THE PIEZOELECTRIC MATERIAL.(EXAMPLE;CRYSTAL PIECE))

WE WILL NOT TAKE ANY RESPONSIBILITY FOR THE INFLUENCE OF THE CUSTOMERS' PROCESS.

SO, PLEASE SUFFICIENTLY EVALUATE AT A SAMPLE STEP WHEN YOU USE ULTRASONIC WELDING MACHINE.

(4) USING RESIN MOLD MAY AFFECT THE PRODUCT CHARACTERISTIC.

PLEASE MAKE SURE TO TELL OUR SALES CONTACT WHEN YOU USE RESIN MOLD. WE WILL PERFORM INDIVIDUAL CORRESPONDENCE ABOUT A DELIVERY SPECIFICATION AND A EVALUATION METHOD.

IN ADDITION, IF YOU USE RESIN MOLD WITHOUT CONTACTING US, AND CAUSES DAMAGES AGAINST A CUSTOMER OR A THIRD PARTY, WE WILL NOT BE LIABLE FOR THE DAMAGES AND OTHER RESPONSIBILITIES BECAUSE WE CONSIDER IT IS UNDER SELF-RESPONSIBILITY USING RESIN MOLD.

WE WILL NOT TAKE ANY RESPONSIBILITY FOR THE INFLUENCE OF THE CUSTOMERS' PROCESS. PLEASE EFFICIENTLY EVALUATE AT A SAMPLE STEP WHEN YOU USE RESIN MOLD.

(5) WHEN PERFORMING IMPROPER HANDLING THAT EXCEEDS THE GUARANTEED RANGE.

3 This product can not be used for equipment related to the safety of automobiles or equipment directly involved in operation.(example: air bag, TPMS, engine control, steering control, brake control etc.)

## Notes on storage

- 1 When storing the product in high temperature and high humidity condition for a long time, product characteristics (solderability etc.) and packaging condition may be deteriorated. Please store product at temperature + 5 °C to + 35 °C, humidity 85 % RH or less. The product is an electronic component, so please do not storage and use, under a dewing state.
- 2 The product storage deadline is 12 months after delivery in unopened state. Please use within storage deadline. If you exceed storage deadline, please check the product characteristics etc, please use.

## Handling of this document and other requests

Please refer to the " Site Guidance" on our website for the handling of information contained in this document. (<https://www.ndk.com/en/terms/>)