

TO251A PACKAGE OUTLINE

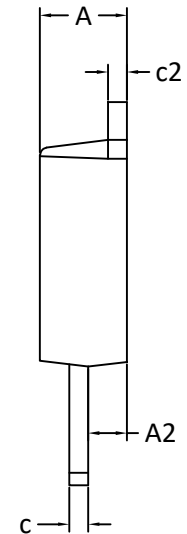

RECOMMENDED LAND PATTERN

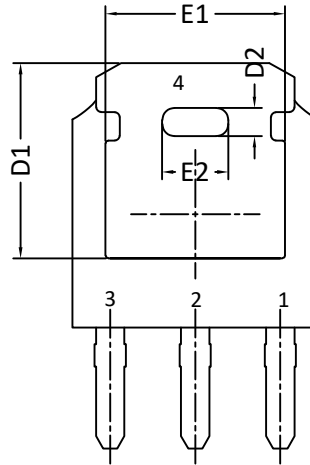
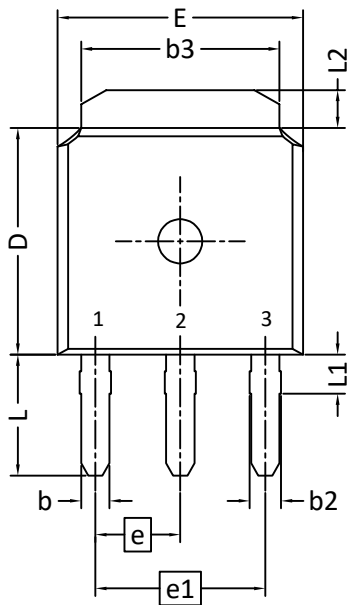
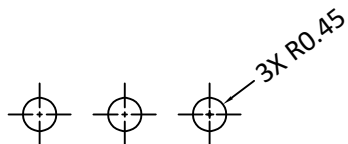

UNIT: mm

SYMBOLS	DIM. IN MM			DIM. IN INCH		
	MIN.	NOM.	MAX.	MIN.	NOM.	MAX.
A	2.180	2.290	2.390	0.086	0.090	0.094
A2	0.890	-----	1.140	0.035	-----	0.045
b	0.630	0.760	0.850	0.025	0.030	0.033
b2	0.760	-----	1.050	0.030	-----	0.041
b3	4.950	-----	5.460	0.195	-----	0.215
c	0.460	0.510	0.610	0.018	0.020	0.024
c2	0.460	-----	0.610	0.018	-----	0.024
D	5.970	6.100	6.220	0.235	0.240	0.245
D1	5.210	-----	-----	0.205	-----	-----
D2	0.508BSC			0.02BSC		
E	6.350	6.600	6.730	0.250	0.260	0.265
E1	4.318	-----	-----	0.170	-----	-----
E2	1.524BSC			0.06BSC		
e	2.29BSC			0.09BSC		
e1	4.57BSC			0.18BSC		
L	3.700	4.050	4.400	0.146	0.159	0.173
L1	1.05REF			0.041REF		
L2	0.890	-----	1.270	0.035	-----	0.050

NOTE

1. PACKAGE BODY SIZES EXCLUDE MOLD FLASH AND GATE BURRS. MOLD FLASH SHOULD BE LESS THAN 6 MILS.
2. DIMENSION L IS MEASURED IN GAUGE PLANE
3. TOLERANCE 0.10 mm UNLESS OTHERWISE SPECIFIED
4. CONTROLLING DIMENSION IS MILLIMETER. CONVERTED INCH DIMENSIONS ARE NOT NECESSARILY EXACT.
5. REFER TO JEDEC TO-252 (AA)