

REVISIONS				
P	LTR	DESCRIPTION	DATE	OWN
G		REV PER ECO 17-007893	6-5-17	CT DM

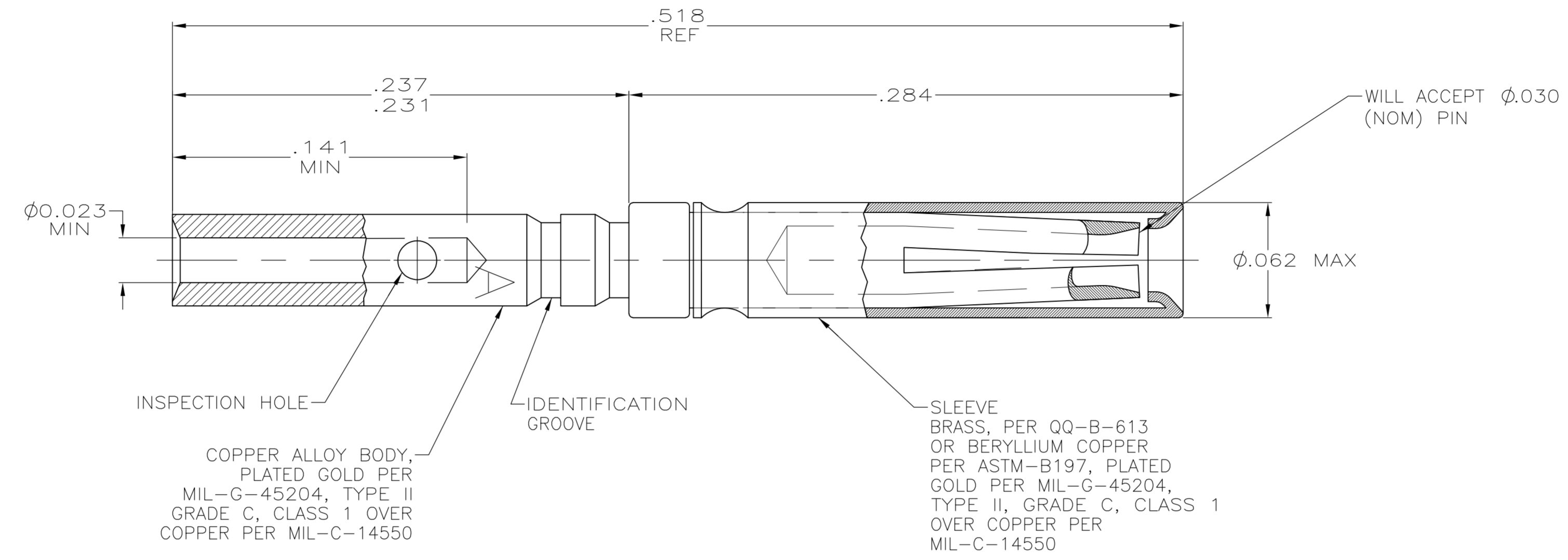

PRESS FIT HOOD CONFIGURATION

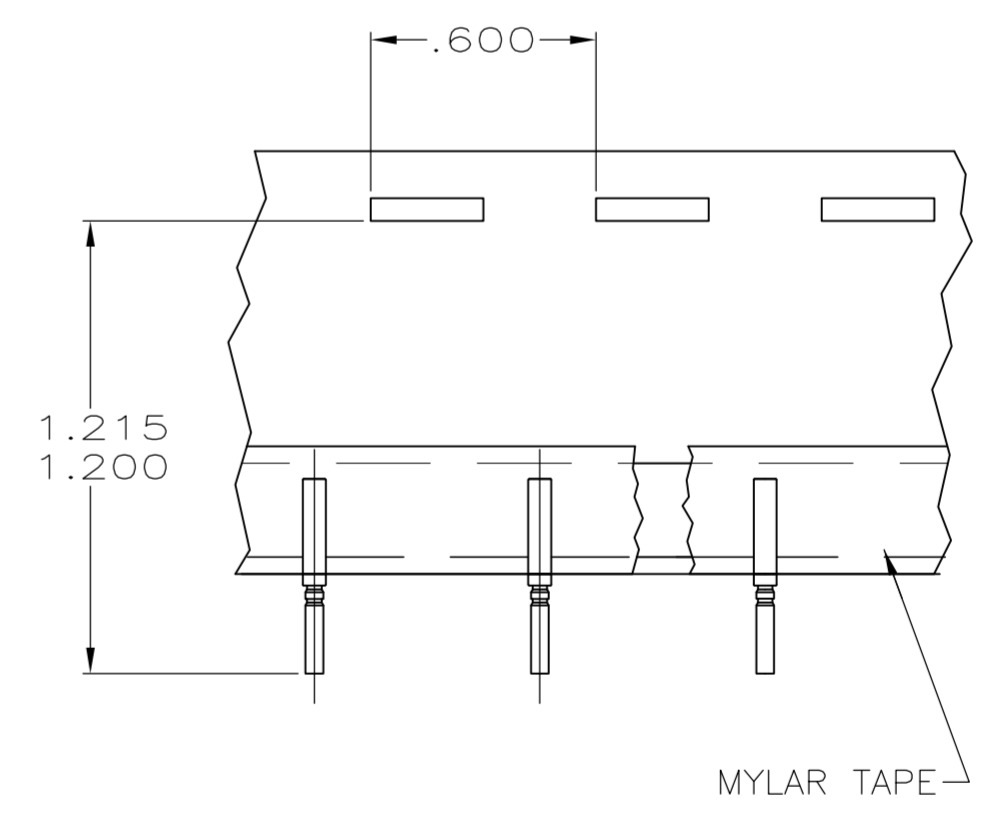

TAPE MOUNTED -2 ONLY

1. WIRE BARREL WILL ACCEPT #26 - 28 AWG WIRE.
 2. CRIMPING TOOL - USE HANDTOOL M22520/2-01 (AMP P/N 601996-1) WITH POSITIONER M22520/2-06 (AMP P/N 601966-4) SEE AMP INSTRUCTION SHEET, IS7516, FOR CRIMPING INSTRUCTIONS.
 3. CONTACT CONFORMS TO MIL-C-24308/57-354, EXCEPT NO COLOR CODE AND INSIDE DIAMETER ON CRIMP BARREL IS SMALLER TO ACCEPT #26 - 28 AWG WIRE.
 4. INSERTION/EXTRACTION TOOL AMP P/N 91067-1.
 5. USE AMP - TAPEMATIC STRIPPER/CRIMPER MACHINE NUMBER 299406-7 WITH FUNNEL NUMBER 125905-2.
 6. SLEEVE MAY BE CRIMPED OR DIMPLED ONTO CONTACT BODY.
- RESTRICTED TO SPACE SYSTEMS LORAL.

REMARKS	DESCRIPTION	PART NO.
7	AS SHOWN	206496-4
5	AS SHOWN EXCEPT EVCEPT ON TAPE	206496-2
2	AS SHOWN	206496-1

THIS DRAWING IS A CONTROLLED DOCUMENT. DWG: T. THOMPSON 06-03-94
 CHK: F. KINSEY
 APVD: F. KINSEY
 PRODUCT SPEC: -
 APPLICATION SPEC: -
 MATERIAL: SEE CALLOUT FINISH: -
 WEIGHT: 0.000000
 CUSTOMER DRAWING

STE TE Connectivity
 NAME: CONTACT ASSEMBLY, SOCKET, SIZE 22D
 SIZE: A1 CAGE CODE: 00779 DRAWING NO: 206496
 RESTRICTED TO: -
 SCALE: 20:1 SHEET: 1 OF 1 REV: G