

Product Specification

NHD-5.0-HDMI-N-RTXL

TFT Liquid Crystal Display

NHD-	Newhaven Display
5.0-	5" Diagonal
HDMI-	HDMI Interface
N-	800x480 Resolution
RTXL-	Premium (MVA) Display

Table of Contents

Document Revision History	2
Mechanical Drawing	3
Schematics	4
Electrical Characteristics	7
HDMI Receiver Information	7
Technical Resource	7
EDID Array	8
EDID Timing	8
Quality Information	9

Additional Resources

- **Support Forum:** <http://www.nhdforum.newhavendisplay.com>
- **Github:** <https://github.com/newhavendisplay>
- **Example Code:** https://www.newhavendisplay.com/example_code.html
- **Knowledge Center:** https://www.newhavendisplay.com/knowledge_center.html
- **Quality Center:** https://www.newhavendisplay.com/quality_center.html
- **Precautions for using LCDs/LCMs:** <https://www.newhavendisplay.com/specs/precautions.pdf>
- **Warranty / Terms & Conditions:** <https://www.newhavendisplay.com/terms.html>



Document Revision History

Revision	Date	Description	Changed By
0	04/22/2021	Initial Release	ZP
1	01/25/2022	Updated Spec Format	ZP

Mechanical Drawing

SYMBOL	REVISION	DATE

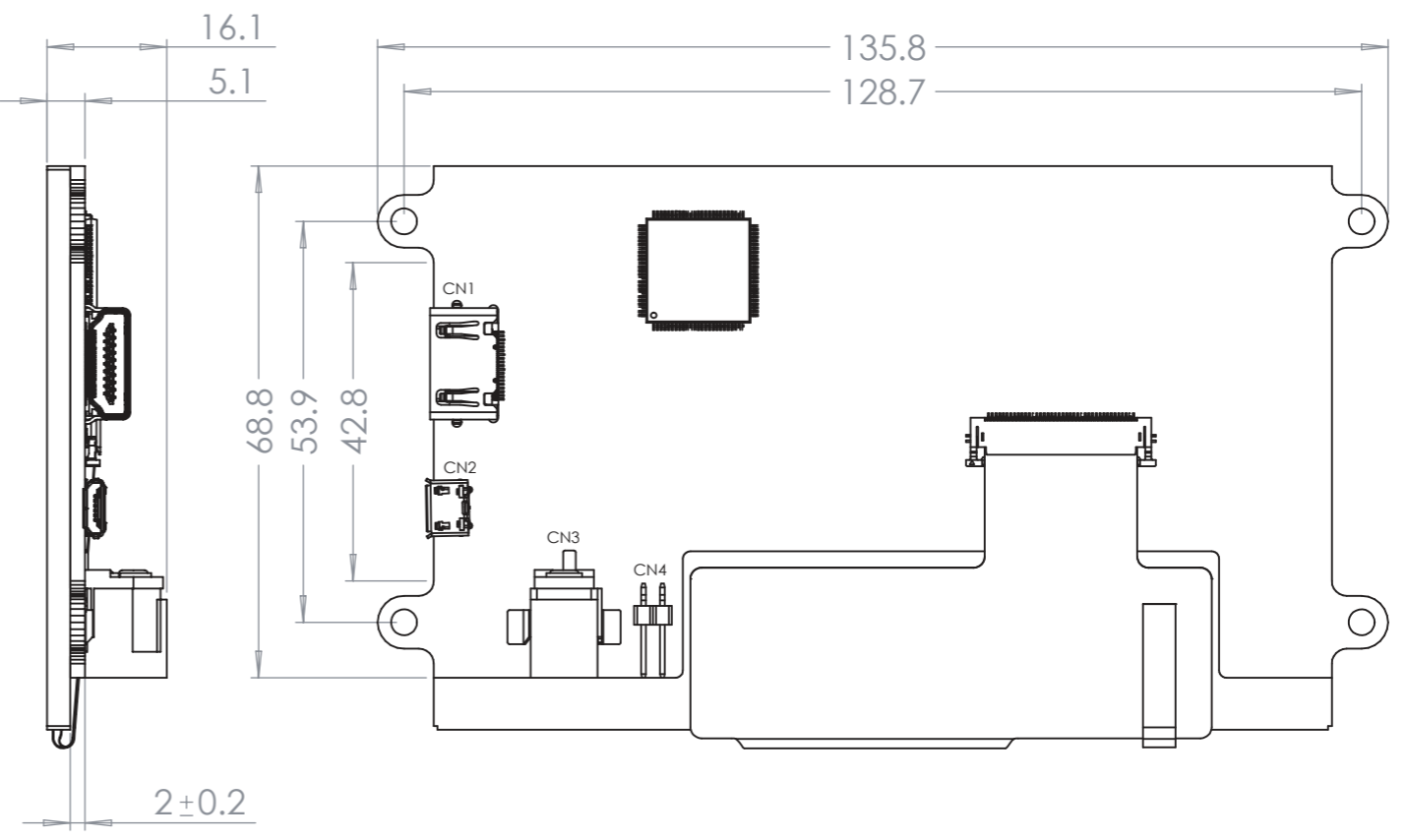
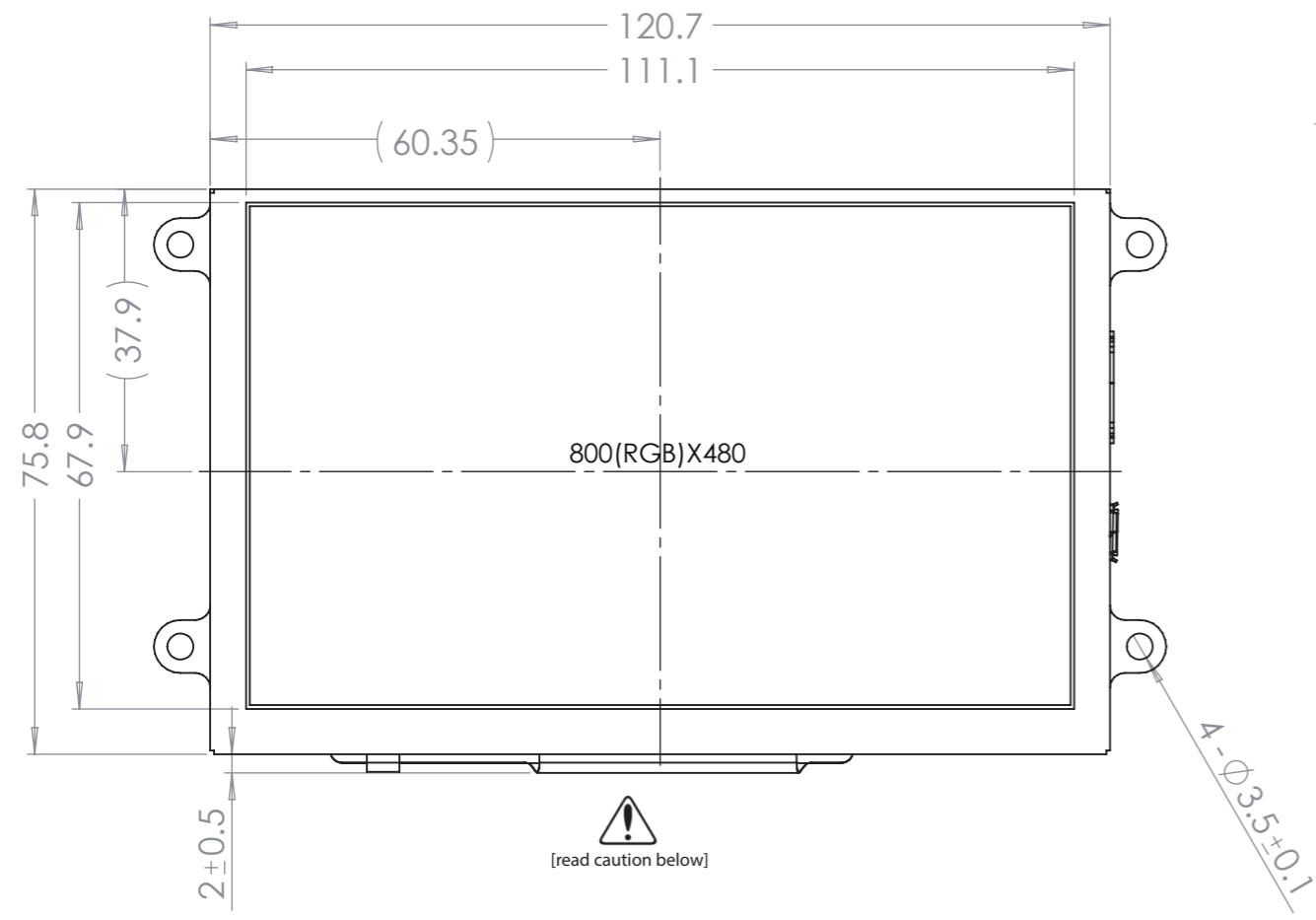

Product Description: 5.0" Premium HDMI TFT Module

1. TFT Driver IC: TFP401A
2. TFT Interface: 24-Bit RGB
3. TFT Power Requirement: 5V/1.2A
4. Optical Features: Normally White, Transmissive, Anti-Glare, 620 cd/m2

Improper handling of the FPC connection at the bottom edge of this module may cause damage resulting in display failure. Take special care when handling this area of the display module to make sure this connection is never strained nor creased.

STANDARD TOLERANCE: (UNLESS OTHERWISE SPECIFIED)		
LINEAR: ±0.3mm	DRAWING/PART NUMBER: NHD-5.0-HDMI-N-RTXL	REVISION: -
UNLESS OTHERWISE SPECIFIED: - DIMENSIONS ARE IN MILLIMETERS - THIRD ANGLE PROJECTION	DRAWN BY: Z.Palrang	APPROVED BY: Z.Palrang
	DRAWN DATE: 01/25/2022	APPROVED DATE: 01/25/2022
	DO NOT SCALE DRAWING	SHEET 1 OF 1
THIS DRAWING IS SOLELY THE PROPERTY OF NEWHAVEN DISPLAY INTERNATIONAL, INC. THE INFORMATION IT CONTAINS IS NOT TO BE DISCLOSED, REPRODUCED OR COPIED IN WHOLE OR PART WITHOUT WRITTEN APPROVAL FROM NEWHAVEN DISPLAY.		

TFP401 (DVI/HDMI Decoder)

LCD Interface

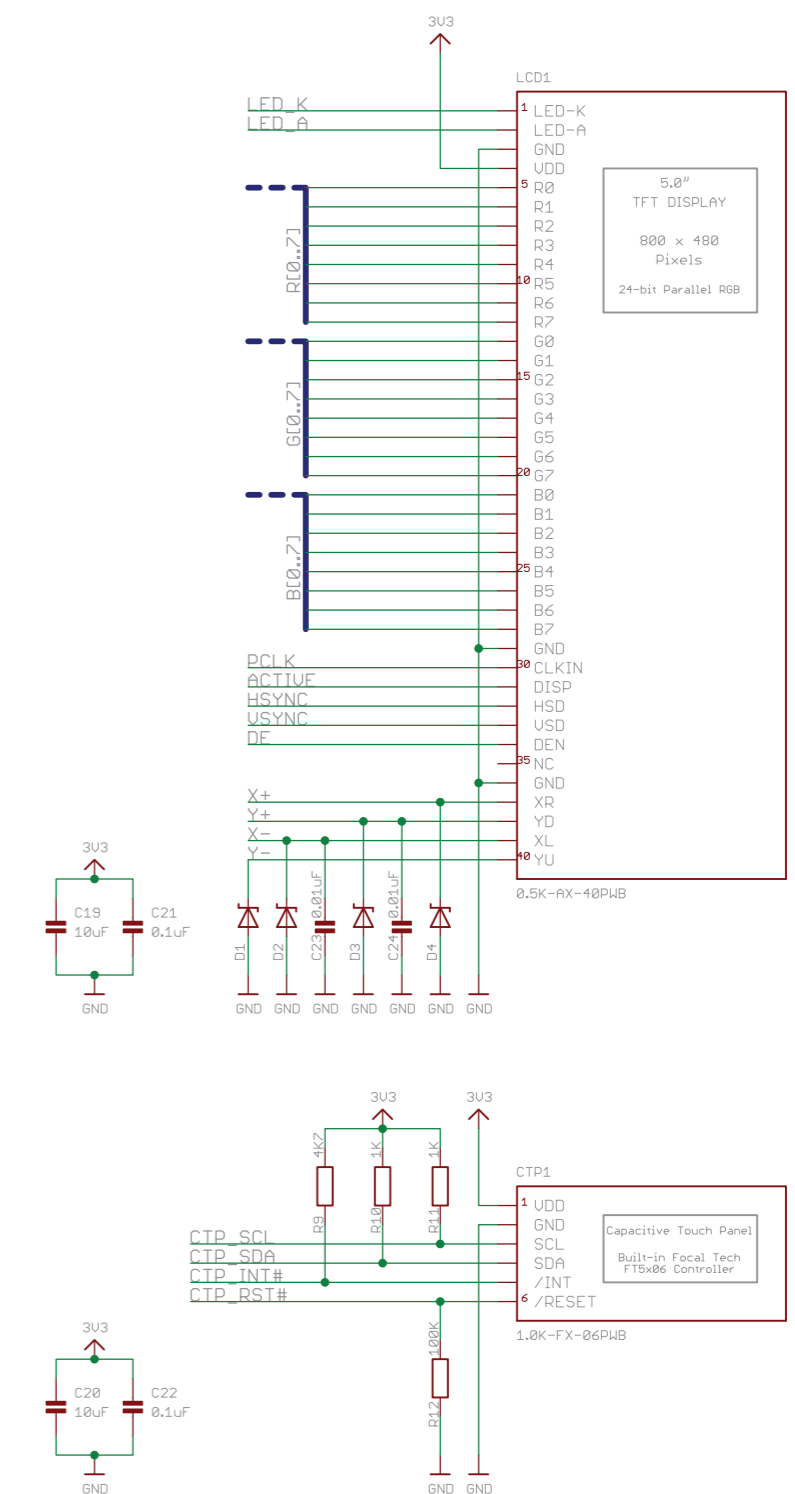
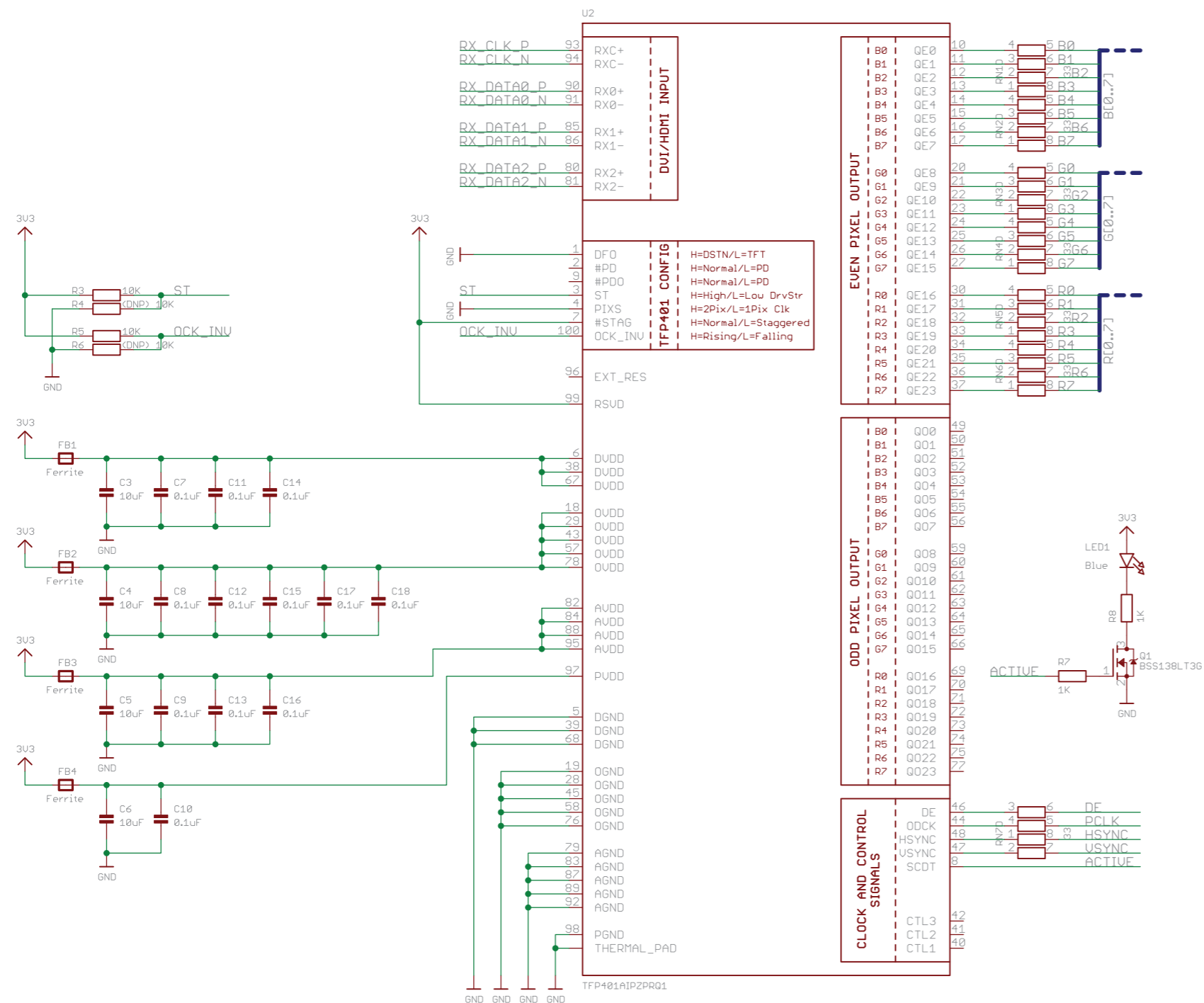

SCHEMATIC / PART NUMBER: NHD-5.0-HDMI-N		REVISION:
DRAWN BY:		SIZE:
DRAWN DATE:		SHEET:
CHECKED BY:		
CHECKED DATE:		

Released under the Creative Commons Attribution
Share-Alike 4.0 License
<http://creativecommons.org/licenses/by-sa/4.0>

Backlight

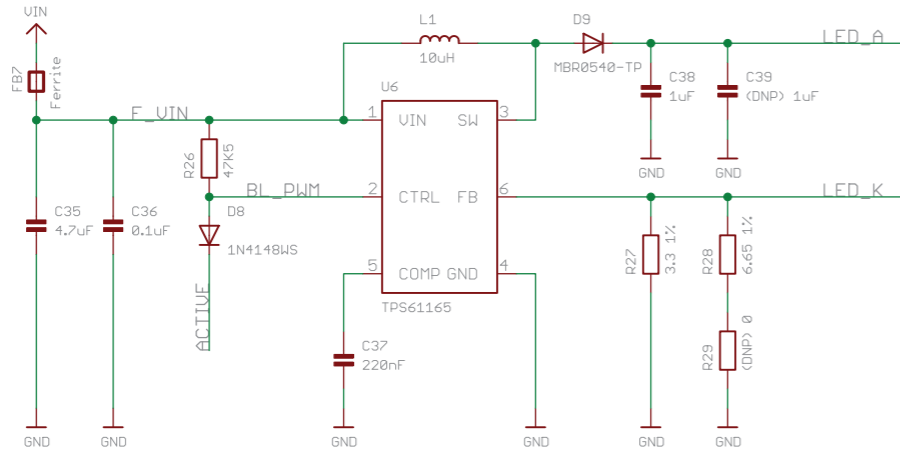

Backlight Configuration		
Current	R29	Display
(Default) ~60mA	Open	ATXL#
~90mA	Close	ASXU#, ASXN#

HDMI-A



3.3V Regulator 800mA

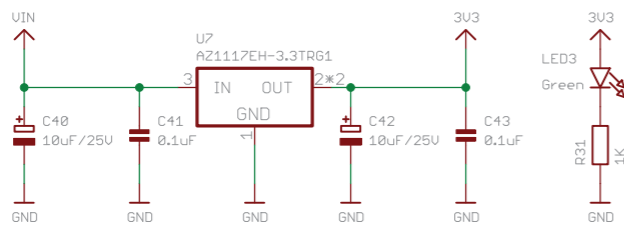

EEPROM

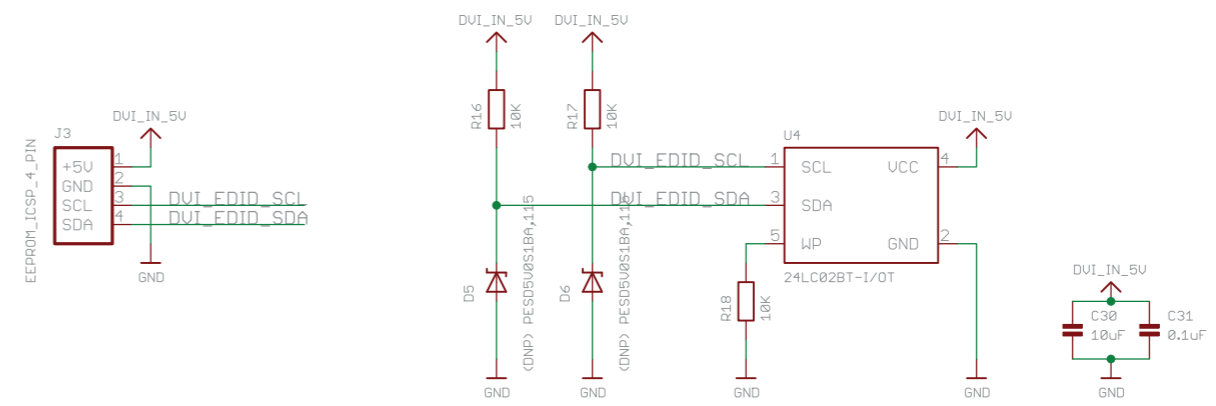

UIN / PWM

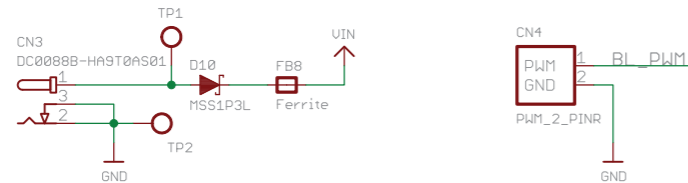

PIC18LF2550 / Capacitive Touch Screen Controller

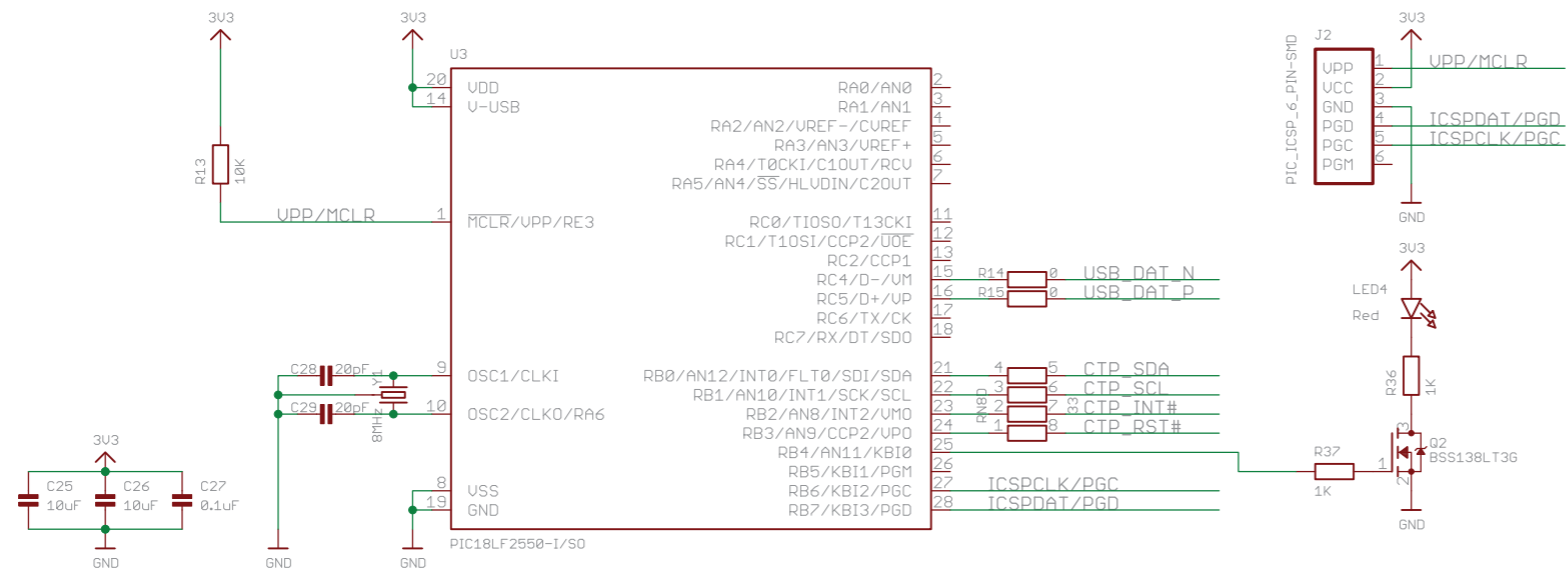

Note: The PIC18LF2550 / Capacitive Touch Screen Controller and necessary components are only populated on the CTU version.

Micro-B USB

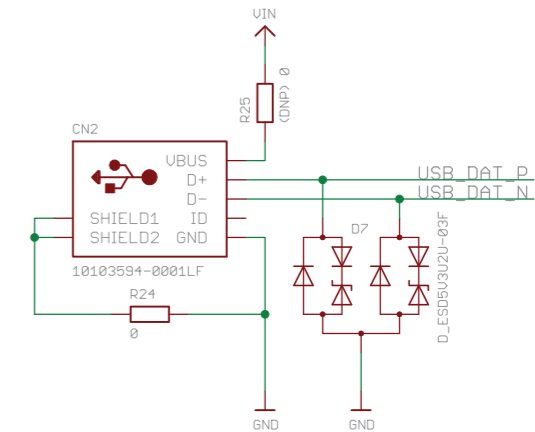

Mounting Holes 3.5mm Plated

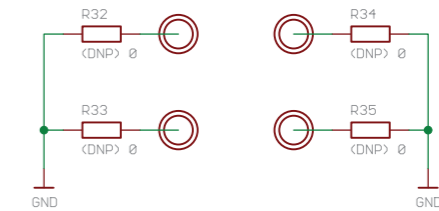

Resistive Touch Screen Controller

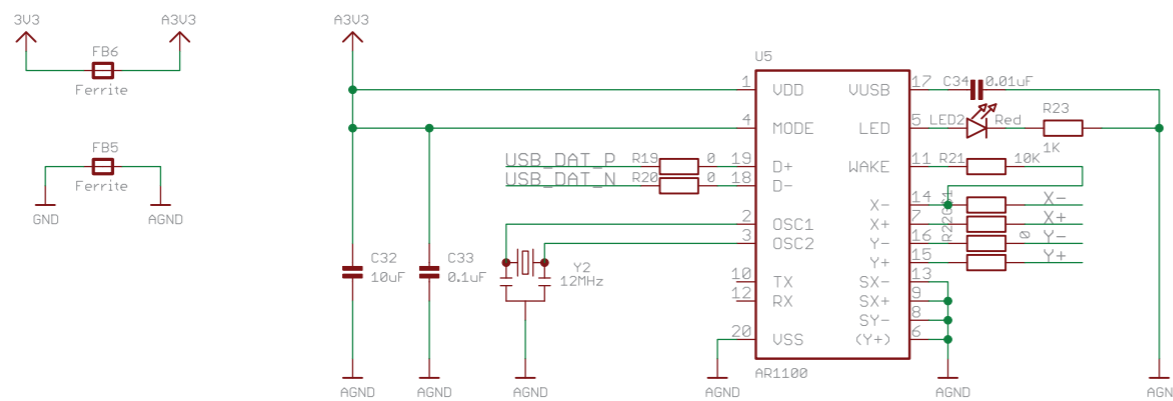

Exposed Pads to Ground TFT Bezel

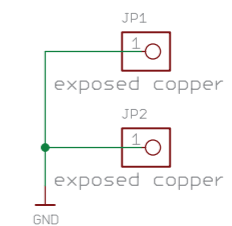

BOARD VERSIONS

RTU Version: (DNP) - C1, C20, C25, C26, C2, C22, C27, C28, C29, C39, CTP1, D1, D2, D3, D4, D5, D6, LED4, Q2, R4, R6, R13, R9, R10, R11, R36, R37, R12, R14, R15, R25, R29, R32, R33, R34, R35, RN8, U1, U3, Y1

CTU Version: (DNP) - C1, C32, C2, C33, C23, C24, C34, C39, D1, D2, D3, D4, D5, D6, FB5, FB6, LED2, R4, R6, R21, R19, R20, R25, R29, R22, R23, R32, R33, R34, R35, U1, U5, Y2

Non-Touch Version: (DNP) - C1, C20, C25, C26, C32, C2, C22, C27, C33, C23, C24, C34, C28, C29, C39, CN2, CTP1, D1, D2, D3, D4, D5, D6, D7, FB5, FB6, LED2, LED4, Q2, R4, R6, R13, R21, R9, R10, R11, R23, R36, R37, R12, R14, R15, R19, R20, R24, R25, R29, R22, R32, R33, R34, R35, RN8, U1, U3, U5, Y1, Y2

		REVISION: 1.1
SCHE MATT C /PART NUMBER: NHD-5.0-HDMI-N		SIZE: A3
DRAWN BY: P. Bartek	CHECKED BY: M. LaVine	SHEET : 3 of 3
DRAWN DATE: 06/01/17	CHECKED DATE: 06/02/17	
Released under the Creative Commons Attribution Share-Alike 4.0 License http://creativecommons.org/licenses/by-sa/4.0		

Electrical Characteristics

Item	Symbol	Condition	Min.	Typical	Max.	Unit
Operating Temperature Range	T _{OP}	Absolute Max	-20	-	+70	°C
Storage Temperature Range	T _{ST}	Absolute Max	-30	-	+80	°C
Backlight PWM Voltage	V _{PWM}	-	2.5	3.3	5.5	V
Backlight PWM Frequency	f _{PWM}	V _{PWM} = 3.3V	5	-	100	kHz
Module Supply Voltage	V _{DD}	-	5.0	-	7.0	V
Module Supply Current	I _{DD}	V _{DD} = 5V	-	1.2	1.5	A
		V _{DD} = 7V	-	0.9	1.2	A

HDMI Receiver Information

On-board Texas Instruments TFP401A Receiver. To view the full TFP401A specification, please download it by accessing the link: <http://www.ti.com/lit/ds/slids190a/slids190a.pdf>

Technical Resource

3D Model	TFT Panel Used	Display Type	Luminance Rating	Optimal Viewing Angle	Touch Panel
NHD-5.0-HDMI-N-RTXL	NHD-5.0-800480TF-ATXL#	Premium MVA	620 cd/m ²	70° all angles	No Touch

Quality Information

Test Item	Content of Test	Test Condition	Note
High Temperature storage	Endurance test applying the high storage temperature for a long time.	+80°C, 96 hrs.	2
Low Temperature storage	Endurance test applying the low storage temperature for a long time.	-30°C, 96 hrs.	1,2
High Temperature Operation	Endurance test applying the electric stress (voltage & current) and the high thermal stress for a long time.	+70°C, 96 hrs.	2
Low Temperature Operation	Endurance test applying the electric stress (voltage & current) and the low thermal stress for a long time.	-20°C, 96 hrs.	1,2
High Temperature / Humidity Operation	Endurance test applying the electric stress (voltage & current) and the high thermal with high humidity stress for a long time.	+60°C, 90% RH, 96 hrs.	1,2
Thermal Shock resistance	Endurance test applying the electric stress (voltage & current) during a cycle of low and high thermal stress.	-20°C, 30min->25°C, 5min -> 70°C, 30min = 1 Cycle 10 cycles	
Vibration test	Endurance test applying vibration to simulate transportation and use.	10-55Hz, 15mm amplitude. 60 sec in each of 3 directions X,Y,Z For 15 minutes	3
Static electricity test	Endurance test applying electric static discharge.	Air: $V_s = \pm 8KV$, Contact: $V_s = \pm 4KV$ 10 Times	

Note 1: No condensation to be observed.

Note 2: Conducted after 4 hours of storage at 25°C, 0%RH.

Note 3: Test performed on product itself, not inside a container.