

To our customers,

Old Company Name in Catalogs and Other Documents

On April 1st, 2010, NEC Electronics Corporation merged with Renesas Technology Corporation, and Renesas Electronics Corporation took over all the business of both companies. Therefore, although the old company name remains in this document, it is a valid Renesas Electronics document. We appreciate your understanding.

Renesas Electronics website: <http://www.renesas.com>

April 1st, 2010
Renesas Electronics Corporation

Issued by: Renesas Electronics Corporation (<http://www.renesas.com>)

Send any inquiries to <http://www.renesas.com/inquiry>.

Notice

1. All information included in this document is current as of the date this document is issued. Such information, however, is subject to change without any prior notice. Before purchasing or using any Renesas Electronics products listed herein, please confirm the latest product information with a Renesas Electronics sales office. Also, please pay regular and careful attention to additional and different information to be disclosed by Renesas Electronics such as that disclosed through our website.
2. Renesas Electronics does not assume any liability for infringement of patents, copyrights, or other intellectual property rights of third parties by or arising from the use of Renesas Electronics products or technical information described in this document. No license, express, implied or otherwise, is granted hereby under any patents, copyrights or other intellectual property rights of Renesas Electronics or others.
3. You should not alter, modify, copy, or otherwise misappropriate any Renesas Electronics product, whether in whole or in part.
4. Descriptions of circuits, software and other related information in this document are provided only to illustrate the operation of semiconductor products and application examples. You are fully responsible for the incorporation of these circuits, software, and information in the design of your equipment. Renesas Electronics assumes no responsibility for any losses incurred by you or third parties arising from the use of these circuits, software, or information.
5. When exporting the products or technology described in this document, you should comply with the applicable export control laws and regulations and follow the procedures required by such laws and regulations. You should not use Renesas Electronics products or the technology described in this document for any purpose relating to military applications or use by the military, including but not limited to the development of weapons of mass destruction. Renesas Electronics products and technology may not be used for or incorporated into any products or systems whose manufacture, use, or sale is prohibited under any applicable domestic or foreign laws or regulations.
6. Renesas Electronics has used reasonable care in preparing the information included in this document, but Renesas Electronics does not warrant that such information is error free. Renesas Electronics assumes no liability whatsoever for any damages incurred by you resulting from errors in or omissions from the information included herein.
7. Renesas Electronics products are classified according to the following three quality grades: "Standard", "High Quality", and "Specific". The recommended applications for each Renesas Electronics product depends on the product's quality grade, as indicated below. You must check the quality grade of each Renesas Electronics product before using it in a particular application. You may not use any Renesas Electronics product for any application categorized as "Specific" without the prior written consent of Renesas Electronics. Further, you may not use any Renesas Electronics product for any application for which it is not intended without the prior written consent of Renesas Electronics. Renesas Electronics shall not be in any way liable for any damages or losses incurred by you or third parties arising from the use of any Renesas Electronics product for an application categorized as "Specific" or for which the product is not intended where you have failed to obtain the prior written consent of Renesas Electronics. The quality grade of each Renesas Electronics product is "Standard" unless otherwise expressly specified in a Renesas Electronics data sheets or data books, etc.

"Standard": Computers; office equipment; communications equipment; test and measurement equipment; audio and visual equipment; home electronic appliances; machine tools; personal electronic equipment; and industrial robots.

"High Quality": Transportation equipment (automobiles, trains, ships, etc.); traffic control systems; anti-disaster systems; anti-crime systems; safety equipment; and medical equipment not specifically designed for life support.

"Specific": Aircraft; aerospace equipment; submersible repeaters; nuclear reactor control systems; medical equipment or systems for life support (e.g. artificial life support devices or systems), surgical implantations, or healthcare intervention (e.g. excision, etc.), and any other applications or purposes that pose a direct threat to human life.

8. You should use the Renesas Electronics products described in this document within the range specified by Renesas Electronics, especially with respect to the maximum rating, operating supply voltage range, movement power voltage range, heat radiation characteristics, installation and other product characteristics. Renesas Electronics shall have no liability for malfunctions or damages arising out of the use of Renesas Electronics products beyond such specified ranges.
9. Although Renesas Electronics endeavors to improve the quality and reliability of its products, semiconductor products have specific characteristics such as the occurrence of failure at a certain rate and malfunctions under certain use conditions. Further, Renesas Electronics products are not subject to radiation resistance design. Please be sure to implement safety measures to guard them against the possibility of physical injury, and injury or damage caused by fire in the event of the failure of a Renesas Electronics product, such as safety design for hardware and software including but not limited to redundancy, fire control and malfunction prevention, appropriate treatment for aging degradation or any other appropriate measures. Because the evaluation of microcomputer software alone is very difficult, please evaluate the safety of the final products or system manufactured by you.
10. Please contact a Renesas Electronics sales office for details as to environmental matters such as the environmental compatibility of each Renesas Electronics product. Please use Renesas Electronics products in compliance with all applicable laws and regulations that regulate the inclusion or use of controlled substances, including without limitation, the EU RoHS Directive. Renesas Electronics assumes no liability for damages or losses occurring as a result of your noncompliance with applicable laws and regulations.
11. This document may not be reproduced or duplicated, in any form, in whole or in part, without prior written consent of Renesas Electronics.
12. Please contact a Renesas Electronics sales office if you have any questions regarding the information contained in this document or Renesas Electronics products, or if you have any other inquiries.

(Note 1) "Renesas Electronics" as used in this document means Renesas Electronics Corporation and also includes its majority-owned subsidiaries.

(Note 2) "Renesas Electronics product(s)" means any product developed or manufactured by or for Renesas Electronics.

The revision list can be viewed directly by clicking the title page.

The revision list summarizes the locations of revisions and additions. Details should always be checked by referring to the relevant text.

H8/3068F-ZTAT™

Hardware Manual

Renesas 16-Bit Single-Chip Microcomputer

H8 Family/H8/300H Series

H8/3068F HD64F3068F,
HD64F3068TE

Keep safety first in your circuit designs!

1. Renesas Technology Corp. puts the maximum effort into making semiconductor products better and more reliable, but there is always the possibility that trouble may occur with them. Trouble with semiconductors may lead to personal injury, fire or property damage.
Remember to give due consideration to safety when making your circuit designs, with appropriate measures such as (i) placement of substitutive, auxiliary circuits, (ii) use of nonflammable material or (iii) prevention against any malfunction or mishap.

Notes regarding these materials

1. These materials are intended as a reference to assist our customers in the selection of the Renesas Technology Corp. product best suited to the customer's application; they do not convey any license under any intellectual property rights, or any other rights, belonging to Renesas Technology Corp. or a third party.
2. Renesas Technology Corp. assumes no responsibility for any damage, or infringement of any third-party's rights, originating in the use of any product data, diagrams, charts, programs, algorithms, or circuit application examples contained in these materials.
3. All information contained in these materials, including product data, diagrams, charts, programs and algorithms represents information on products at the time of publication of these materials, and are subject to change by Renesas Technology Corp. without notice due to product improvements or other reasons. It is therefore recommended that customers contact Renesas Technology Corp. or an authorized Renesas Technology Corp. product distributor for the latest product information before purchasing a product listed herein.
The information described here may contain technical inaccuracies or typographical errors. Renesas Technology Corp. assumes no responsibility for any damage, liability, or other loss rising from these inaccuracies or errors.
Please also pay attention to information published by Renesas Technology Corp. by various means, including the Renesas Technology Corp. Semiconductor home page (<http://www.renesas.com>).
4. When using any or all of the information contained in these materials, including product data, diagrams, charts, programs, and algorithms, please be sure to evaluate all information as a total system before making a final decision on the applicability of the information and products. Renesas Technology Corp. assumes no responsibility for any damage, liability or other loss resulting from the information contained herein.
5. Renesas Technology Corp. semiconductors are not designed or manufactured for use in a device or system that is used under circumstances in which human life is potentially at stake. Please contact Renesas Technology Corp. or an authorized Renesas Technology Corp. product distributor when considering the use of a product contained herein for any specific purposes, such as apparatus or systems for transportation, vehicular, medical, aerospace, nuclear, or undersea repeater use.
6. The prior written approval of Renesas Technology Corp. is necessary to reprint or reproduce in whole or in part these materials.
7. If these products or technologies are subject to the Japanese export control restrictions, they must be exported under a license from the Japanese government and cannot be imported into a country other than the approved destination.
Any diversion or reexport contrary to the export control laws and regulations of Japan and/or the country of destination is prohibited.
8. Please contact Renesas Technology Corp. for further details on these materials or the products contained therein.

Preface

The H8/3068F is a group of high-performance single-chip microcontrollers that integrate system supporting functions together with an H8/300H CPU core.

The H8/300H CPU has a 32-bit internal architecture with sixteen 16-bit general registers, and a concise, optimized instruction set designed for speed. It can address a 16-Mbyte linear address space.

The on-chip supporting functions include ROM, RAM, 16-bit timers, 8-bit timers, a programmable timing pattern controller (TPC), a watchdog timer (WDT), a serial communication interface (SCI), an A/D converter, a D/A converter, I/O ports, a DMA controller (DMAC), and other facilities. The three-channel SCI has been expanded to support the ISO/IEC7816-3 smart card interface. Functions have also been added to reduce power consumption in battery-powered applications: individual modules can be placed in standby, and the frequency of the system clock supplied to the chip can be divided down under software control.

The address space is divided into eight areas. The data bus width and access cycle length can be selected independently in each area, simplifying the connection of different types of memory. Seven MCU operating modes (modes 1 to 7) are provided, offering a choice of data bus width and address space size.

With these features, the H8/3068F offers easy implementation of compact, high-performance systems.

The H8/3068F has an F-ZTAT™* version with on-chip flash memory that can be programmed on-board. This version enables users to respond quickly and flexibly to changing application specifications.

This manual describes the H8/3068F hardware. For details of the instruction set, refer to the H8/300H Series Programming Manual.

Note: * F-ZTAT™ (Flexible ZTAT) is a registered trademark of Renesas Technology Corp.

Main Revisions for this Edition

Item	Page	Revision (See Manual for Details)
All	—	All references to Hitachi, Hitachi, Ltd., Hitachi Semiconductors, and other Hitachi brand names changed to Renesas Technology Corp. Designation for categories changed from “series” to “group”
19.2.1 Connecting a Crystal Resonator Table 19.1 (1) Damping Resistance Value	651	Note amended Note: A crystal resonator between 2 MHz and 25 MHz can be used. If the chip is to be operated at less than 2 MHz, the on-chip frequency divider should be used. (A crystal resonator of less than 2 MHz cannot be used.)
Section 21 Electrical Characteristics	675 to 706	“Preliminary” deleted

21.1.2 DC Characteristics Table and note amended

Table 21.2 DC Characteristics (1)

Item	Symbol	Min	Typ	Max	Unit	Test Conditions
Current dissipation*2 Normal operation	I_{CC}^{*2}	—	32 (5.0 V)	47	mA	f = 20 MHz
			37 (5.0 V)	58		f = 25 MHz
Sleep mode		—	24 (5.0 V)	38	mA	f = 20 MHz
			29 (5.0 V)	47		f = 25 MHz
Module standby mode		—	19 (5.0 V)	31	mA	f = 20 MHz
			21 (5.0 V)	37		f = 25 MHz
Standby mode*3		—	1.0	10	μ A	T_a 50°C
			—	80		50°C T_a
Flash memory programming/erasing*5		—	37	57	mA	f = 20 MHz
			42	68		f = 25 MHz

Notes: 3. The values are for $V_{RAM} \leq V_{CC} < 4.5$ V, $V_{IH} \text{ min} = V_{CC} \times 0.9$, and $V_{IL} \text{ max} = 0.3$ V.

4. $I_{CC} \text{ max. (normal operation)}$
 $= 3.0 \text{ (mA)} + 0.40 \text{ (mA/(MHz} \times \text{V))} \times V_{CC} \times f$
 $I_{CC} \text{ max. (sleep mode)}$
 $= 3.0 \text{ (mA)} + 0.32 \text{ (mA/(MHz} \times \text{V))} \times V_{CC} \times f$
 $I_{CC} \text{ max. (sleep mode + module standby mode)}$
 $= 3.0 \text{ (mA)} + 0.25 \text{ (mA/(MHz} \times \text{V))} \times V_{CC} \times f$

The Typ values for power consumption are reference values.

5. Sum of current dissipation in normal operation and current dissipation in program/erase operations.

21.1.6 Flash 690, 691 Table amended and notes added

Memory
Characteristics

Table 21.10 Flash

Memory
Characteristics

Item	Symbol	Min	Typ	Max	Unit	Notes
Programming time ^{a1} ^{a2} ^{a4}	t _P	—	10	200	ms/ 128 bytes	
Erase time ^{a1} ^{a3} ^{a5}	t _E	—	100	1200	ms/block	
Reprogramming count	N _{WEC}	100 ^{a6}	10,000 ^{a7}	—	Times	
Data retention period	t _{DRP}	10 ^{a8}	—	—	Years	

- Notes:
6. Minimum number of times at which all characteristics are guaranteed after reprogramming. (Reprogramming count from 1 to minimum value is guaranteed.)
 7. Reference characteristics at 25°C. (This is an indication that reprogramming operations can normally be performed up to this figure.)
 8. Data retention characteristics when reprogramming is performed correctly within the specification values, including the minimum data retention period.

Contents

Section 1	Overview	1
1.1	Overview	1
1.2	Block Diagram	6
1.3	Pin Description	7
1.3.1	Pin Arrangement	7
1.3.2	Pin Functions	8
1.3.3	Pin Assignments in Each Mode	13
Section 2	CPU	19
2.1	Overview	19
2.1.1	Features	19
2.1.2	Differences from H8/300 CPU	20
2.2	CPU Operating Modes	21
2.3	Address Space	22
2.4	Register Configuration	23
2.4.1	Overview	23
2.4.2	General Registers	24
2.4.3	Control Registers	25
2.4.4	Initial CPU Register Values	26
2.5	Data Formats	27
2.5.1	General Register Data Formats	27
2.5.2	Memory Data Formats	29
2.6	Instruction Set	30
2.6.1	Instruction Set Overview	30
2.6.2	Instructions and Addressing Modes	31
2.6.3	Tables of Instructions Classified by Function	32
2.6.4	Basic Instruction Formats	41
2.6.5	Notes on Use of Bit Manipulation Instructions	42
2.7	Addressing Modes and Effective Address Calculation	44
2.7.1	Addressing Modes	44
2.7.2	Effective Address Calculation	46
2.8	Processing States	50
2.8.1	Overview	50
2.8.2	Program Execution State	51
2.8.3	Exception-Handling State	51
2.8.4	Exception-Handling Sequences	53
2.8.5	Bus-Released State	54

2.8.6	Reset State	54
2.8.7	Power-Down State	55
2.9	Basic Operational Timing	56
2.9.1	Overview	56
2.9.2	On-Chip Memory Access Timing	56
2.9.3	On-Chip Supporting Module Access Timing	57
2.9.4	Access to External Address Space	58
Section 3 MCU Operating Modes		59
3.1	Overview	59
3.1.1	Operating Mode Selection	59
3.1.2	Register Configuration	60
3.2	Mode Control Register (MDCR)	61
3.3	System Control Register (SYSCR)	62
3.4	Operating Mode Descriptions	64
3.4.1	Mode 1	64
3.4.2	Mode 2	64
3.4.3	Mode 3	64
3.4.4	Mode 4	65
3.4.5	Mode 5	65
3.4.6	Mode 6	65
3.4.7	Mode 7	65
3.5	Pin Functions in Each Operating Mode	66
3.6	Memory Map in Each Operating Mode	67
3.6.1	Note on Reserved Areas	67
Section 4 Exception Handling		73
4.1	Overview	73
4.1.1	Exception Handling Types and Priority	73
4.1.2	Exception Handling Operation	73
4.1.3	Exception Vector Table	74
4.2	Reset	76
4.2.1	Overview	76
4.2.2	Reset Sequence	76
4.2.3	Interrupts after Reset	79
4.3	Interrupts	80
4.4	Trap Instruction	81
4.5	Stack Status after Exception Handling	82
4.6	Notes on Stack Usage	83

Section 5	Interrupt Controller	85
5.1	Overview.....	85
5.1.1	Features.....	85
5.1.2	Block Diagram.....	86
5.1.3	Pin Configuration.....	87
5.1.4	Register Configuration.....	87
5.2	Register Descriptions	88
5.2.1	System Control Register (SYSCR).....	88
5.2.2	Interrupt Priority Registers A and B (IPRA, IPRB).....	89
5.2.3	IRQ Status Register (ISR).....	96
5.2.4	IRQ Enable Register (IER).....	97
5.2.5	IRQ Sense Control Register (ISCR)	98
5.3	Interrupt Sources.....	99
5.3.1	External Interrupts	99
5.3.2	Internal Interrupts	100
5.3.3	Interrupt Vector Table	100
5.4	Interrupt Operation	104
5.4.1	Interrupt Handling Process	104
5.4.2	Interrupt Sequence	109
5.4.3	Interrupt Response Time.....	110
5.5	Usage Notes	111
5.5.1	Contention between Interrupt and Interrupt-Disabling Instruction.....	111
5.5.2	Instructions that Inhibit Interrupts	112
5.5.3	Interrupts during EEPMOV Instruction Execution.....	112
Section 6	Bus Controller	113
6.1	Overview.....	113
6.1.1	Features.....	113
6.1.2	Block Diagram.....	115
6.1.3	Pin Configuration.....	116
6.1.4	Register Configuration.....	117
6.2	Register Descriptions	118
6.2.1	Bus Width Control Register (ABWCR).....	118
6.2.2	Access State Control Register (ASTCR)	119
6.2.3	Wait Control Registers H and L (WCRH, WCRL).....	120
6.2.4	Bus Release Control Register (BRCR).....	124
6.2.5	Bus Control Register (BCR).....	126
6.2.6	Chip Select Control Register (CSCR).....	129
6.2.7	DRAM Control Register A (DRCRA).....	130
6.2.8	DRAM Control Register B (DRCRB).....	132

6.2.9	Refresh Timer Control/Status Register (RTMCSR)	135
6.2.10	Refresh Timer Counter (RTCNT).....	136
6.2.11	Refresh Time Constant Register (RTCOR)	137
6.2.12	Address Control Register (ADRCR)	138
6.3	Operation	139
6.3.1	Area Division.....	139
6.3.2	Bus Specifications	141
6.3.3	Memory Interfaces.....	142
6.3.4	Chip Select Signals	143
6.3.5	Address Output Method.....	144
6.4	Basic Bus Interface	146
6.4.1	Overview.....	146
6.4.2	Data Size and Data Alignment.....	146
6.4.3	Valid Strobes	147
6.4.4	Memory Areas	148
6.4.5	Basic Bus Control Signal Timing	150
6.4.6	Wait Control	157
6.5	DRAM Interface	159
6.5.1	Overview.....	159
6.5.2	DRAM Space and $\overline{\text{RAS}}$ Output Pin Settings	159
6.5.3	Address Multiplexing	160
6.5.4	Data Bus	161
6.5.5	Pins Used for DRAM Interface	162
6.5.6	Basic Timing.....	162
6.5.7	Precharge State Control	164
6.5.8	Wait Control	165
6.5.9	Byte Access Control and $\overline{\text{CAS}}$ Output Pin	166
6.5.10	Burst Operation.....	168
6.5.11	Refresh Control.....	174
6.5.12	Examples of Use.....	178
6.5.13	Usage Notes	183
6.6	Interval Timer	186
6.6.1	Operation	186
6.7	Interrupt Sources.....	192
6.8	Burst ROM Interface	192
6.8.1	Overview.....	192
6.8.2	Basic Timing.....	192
6.8.3	Wait Control	193
6.9	Idle Cycle.....	194
6.9.1	Operation	194

6.9.2	Pin States in Idle Cycle	197
6.10	Bus Arbiter.....	198
6.10.1	Operation	198
6.11	Register and Pin Input Timing	201
6.11.1	Register Write Timing	201
6.11.2	$\overline{\text{BREQ}}$ Pin Input Timing	202
Section 7 DMA Controller.....		203
7.1	Overview.....	203
7.1.1	Features.....	203
7.1.2	Block Diagram.....	204
7.1.3	Functional Overview.....	205
7.1.4	Input/Output Pins	206
7.1.5	Register Configuration.....	207
7.2	Register Descriptions (1) (Short Address Mode).....	208
7.2.1	Memory Address Registers (MAR)	208
7.2.2	I/O Address Registers (IOAR).....	209
7.2.3	Execute Transfer Count Registers (ETCR).....	210
7.2.4	Data Transfer Control Registers (DTCR)	211
7.3	Register Descriptions (2) (Full Address Mode)	214
7.3.1	Memory Address Registers (MAR)	214
7.3.2	I/O Address Registers (IOAR).....	214
7.3.3	Execute Transfer Count Registers (ETCR).....	215
7.3.4	Data Transfer Control Registers (DTCR)	217
7.4	Operation	223
7.4.1	Overview.....	223
7.4.2	I/O Mode.....	225
7.4.3	Idle Mode.....	227
7.4.4	Repeat Mode	230
7.4.5	Normal Mode.....	234
7.4.6	Block Transfer Mode	237
7.4.7	DMAC Activation.....	242
7.4.8	DMAC Bus Cycle.....	244
7.4.9	Multiple-Channel Operation	250
7.4.10	External Bus Requests, DRAM Interface, and DMAC.....	251
7.4.11	NMI Interrupts and DMAC	252
7.4.12	Aborting a DMAC Transfer.....	253
7.4.13	Exiting Full Address Mode.....	254
7.4.14	DMAC States in Reset State, Standby Modes, and Sleep Mode	255
7.5	Interrupts.....	256

7.6	Usage Notes	257
7.6.1	Note on Word Data Transfer	257
7.6.2	DMAC Self-Access	257
7.6.3	Longword Access to Memory Address Registers	257
7.6.4	Note on Full Address Mode Setup	257
7.6.5	Note on Activating DMAC by Internal Interrupts	258
7.6.6	NMI Interrupts and Block Transfer Mode	259
7.6.7	Memory and I/O Address Register Values	259
7.6.8	Bus Cycle when Transfer is Aborted	260
7.6.9	Transfer Requests by A/D Converter	261
Section 8 I/O Ports		263
8.1	Overview	263
8.2	Port 1	266
8.2.1	Overview	266
8.2.2	Register Descriptions	267
8.3	Port 2	269
8.3.1	Overview	269
8.3.2	Register Descriptions	270
8.4	Port 3	273
8.4.1	Overview	273
8.4.2	Register Descriptions	273
8.5	Port 4	275
8.5.1	Overview	275
8.5.2	Register Descriptions	276
8.6	Port 5	279
8.6.1	Overview	279
8.6.2	Register Descriptions	280
8.7	Port 6	283
8.7.1	Overview	283
8.7.2	Register Descriptions	284
8.8	Port 7	287
8.8.1	Overview	287
8.8.2	Register Description	288
8.9	Port 8	289
8.9.1	Overview	289
8.9.2	Register Descriptions	291
8.10	Port 9	295
8.10.1	Overview	295
8.10.2	Register Descriptions	296

8.11	Port A.....	300
8.11.1	Overview.....	300
8.11.2	Register Descriptions.....	302
8.12	Port B.....	312
8.12.1	Overview.....	312
8.12.2	Register Descriptions.....	314
Section 9 16-Bit Timer.....		321
9.1	Overview.....	321
9.1.1	Features.....	321
9.1.2	Block Diagrams.....	323
9.1.3	Pin Configuration.....	326
9.1.4	Register Configuration.....	327
9.2	Register Descriptions.....	328
9.2.1	Timer Start Register (TSTR).....	328
9.2.2	Timer Synchro Register (TSNC).....	329
9.2.3	Timer Mode Register (TMDR).....	331
9.2.4	Timer Interrupt Status Register A (TISR A).....	333
9.2.5	Timer Interrupt Status Register B (TISR B).....	336
9.2.6	Timer Interrupt Status Register C (TISR C).....	339
9.2.7	Timer Counters (16TCNT).....	341
9.2.8	General Registers (GRA, GRB).....	342
9.2.9	Timer Control Registers (16TCR).....	343
9.2.10	Timer I/O Control Register (TIOR).....	346
9.2.11	Timer Output Level Setting Register C (TOLR).....	348
9.3	CPU Interface.....	350
9.3.1	16-Bit Accessible Registers.....	350
9.3.2	8-Bit Accessible Registers.....	352
9.4	Operation.....	353
9.4.1	Overview.....	353
9.4.2	Basic Functions.....	354
9.4.3	Synchronization.....	361
9.4.4	PWM Mode.....	363
9.4.5	Phase Counting Mode.....	367
9.4.6	16-Bit Timer Output Timing.....	369
9.5	Interrupts.....	370
9.5.1	Setting of Status Flags.....	370
9.5.2	Timing of Clearing of Status Flags.....	372
9.5.3	Interrupt Sources.....	373
9.6	Usage Notes.....	374

Section 10	8-Bit Timers.....	387
10.1	Overview.....	387
10.1.1	Features.....	387
10.1.2	Block Diagram.....	389
10.1.3	Pin Configuration	390
10.1.4	Register Configuration.....	391
10.2	Register Descriptions.....	392
10.2.1	Timer Counters (8TCNT).....	392
10.2.2	Time Constant Registers A (TCORA).....	393
10.2.3	Time Constant Registers B (TCORB)	394
10.2.4	Timer Control Register (8TCR).....	395
10.2.5	Timer Control/Status Registers (8TCSR)	398
10.3	CPU Interface	403
10.3.1	8-Bit Registers	403
10.4	Operation	405
10.4.1	8TCNT Count Timing	405
10.4.2	Compare Match Timing.....	406
10.4.3	Input Capture Signal Timing	407
10.4.4	Timing of Status Flag Setting	408
10.4.5	Operation with Cascaded Connection.....	409
10.4.6	Input Capture Setting.....	412
10.5	Interrupt	414
10.5.1	Interrupt Sources.....	414
10.5.2	A/D Converter Activation.....	415
10.6	8-Bit Timer Application Example	415
10.7	Usage Notes	416
10.7.1	Contention between 8TCNT Write and Clear.....	416
10.7.2	Contention between 8TCNT Write and Increment	417
10.7.3	Contention between TCOR Write and Compare Match	418
10.7.4	Contention between TCOR Read and Input Capture	419
10.7.5	Contention between Counter Clearing by Input Capture and Counter Increment	420
10.7.6	Contention between TCOR Write and Input Capture	421
10.7.7	Contention between 8TCNT Byte Write and Increment in 16-Bit Count Mode (Cascaded Connection)	422
10.7.8	Contention between Compare Matches A and B	423
10.7.9	8TCNT Operation and Internal Clock Source Switchover	423
Section 11	Programmable Timing Pattern Controller (TPC)	427
11.1	Overview.....	427

11.1.1	Features.....	427
11.1.2	Block Diagram.....	428
11.1.3	TPC Pins	429
11.1.4	Registers	430
11.2	Register Descriptions.....	431
11.2.1	Port A Data Direction Register (PADDR).....	431
11.2.2	Port A Data Register (PADR).....	431
11.2.3	Port B Data Direction Register (PBDDR)	432
11.2.4	Port B Data Register (PBDR)	432
11.2.5	Next Data Register A (NDRA).....	433
11.2.6	Next Data Register B (NDRB)	435
11.2.7	Next Data Enable Register A (NDERA).....	437
11.2.8	Next Data Enable Register B (NDERB)	438
11.2.9	TPC Output Control Register (TPCR).....	439
11.2.10	TPC Output Mode Register (TPMR).....	442
11.3	Operation	444
11.3.1	Overview.....	444
11.3.2	Output Timing.....	445
11.3.3	Normal TPC Output.....	446
11.3.4	Non-Overlapping TPC Output.....	448
11.3.5	TPC Output Triggering by Input Capture	450
11.4	Usage Notes	451
11.4.1	Operation of TPC Output Pins.....	451
11.4.2	Note on Non-Overlapping Output	451
Section 12 Watchdog Timer.....		453
12.1	Overview.....	453
12.1.1	Features.....	453
12.1.2	Block Diagram.....	454
12.1.3	Register Configuration.....	454
12.2	Register Descriptions.....	455
12.2.1	Timer Counter (TCNT).....	455
12.2.2	Timer Control/Status Register (TCSR).....	456
12.2.3	Reset Control/Status Register (RSTCSR).....	458
12.2.4	Notes on Register Access	459
12.3	Operation	461
12.3.1	Watchdog Timer Operation	461
12.3.2	Interval Timer Operation	462
12.3.3	Timing of Setting of Overflow Flag (OVF).....	463
12.3.4	Timing of Setting of Watchdog Timer Reset Bit (WRST)	464

12.4	Interrupts.....	465
12.5	Usage Notes.....	465
Section 13 Serial Communication Interface.....		467
13.1	Overview.....	467
13.1.1	Features.....	467
13.1.2	Block Diagram.....	469
13.1.3	Input/Output Pins.....	470
13.1.4	Register Configuration.....	471
13.2	Register Descriptions.....	472
13.2.1	Receive Shift Register (RSR).....	472
13.2.2	Receive Data Register (RDR).....	472
13.2.3	Transmit Shift Register (TSR).....	473
13.2.4	Transmit Data Register (TDR).....	473
13.2.5	Serial Mode Register (SMR).....	474
13.2.6	Serial Control Register (SCR).....	478
13.2.7	Serial Status Register (SSR).....	483
13.2.8	Bit Rate Register (BRR).....	488
13.3	Operation.....	497
13.3.1	Overview.....	497
13.3.2	Operation in Asynchronous Mode.....	499
13.3.3	Multiprocessor Communication.....	509
13.3.4	Synchronous Operation.....	516
13.4	SCI Interrupts.....	525
13.5	Usage Notes.....	526
13.5.1	Notes on Use of SCI.....	526
Section 14 Smart Card Interface.....		533
14.1	Overview.....	533
14.1.1	Features.....	533
14.1.2	Block Diagram.....	534
14.1.3	Pin Configuration.....	535
14.1.4	Register Configuration.....	536
14.2	Register Descriptions.....	537
14.2.1	Smart Card Mode Register (SCMR).....	537
14.2.2	Serial Status Register (SSR).....	539
14.2.3	Serial Mode Register (SMR).....	540
14.2.4	Serial Control Register (SCR).....	541
14.3	Operation.....	542
14.3.1	Overview.....	542

14.3.2	Pin Connections	542
14.3.3	Data Format	544
14.3.4	Register Settings	545
14.3.5	Clock	547
14.3.6	Transmitting and Receiving Data	549
14.4	Usage Notes	557
Section 15 A/D Converter		561
15.1	Overview	561
15.1.1	Features	561
15.1.2	Block Diagram	562
15.1.3	Input Pins	563
15.1.4	Register Configuration	564
15.2	Register Descriptions	565
15.2.1	A/D Data Registers A to D (ADDRA to ADDR D)	565
15.2.2	A/D Control/Status Register (ADCSR)	566
15.2.3	A/D Control Register (ADCR)	569
15.3	CPU Interface	570
15.4	Operation	572
15.4.1	Single Mode (SCAN = 0)	572
15.4.2	Scan Mode (SCAN = 1)	574
15.4.3	Input Sampling and A/D Conversion Time	576
15.4.4	External Trigger Input Timing	578
15.5	Interrupts	579
15.6	Usage Notes	579
Section 16 D/A Converter		585
16.1	Overview	585
16.1.1	Features	585
16.1.2	Block Diagram	586
16.1.3	Input/Output Pins	586
16.1.4	Register Configuration	587
16.2	Register Descriptions	588
16.2.1	D/A Data Registers 0 and 1 (DADR0/1)	588
16.2.2	D/A Control Register (DACR)	588
16.2.3	D/A Standby Control Register (DASTCR)	590
16.3	Operation	591
16.4	D/A Output Control	592

Section 17	RAM	593
17.1	Overview.....	593
17.1.1	Block Diagram.....	594
17.1.2	Register Configuration.....	594
17.2	System Control Register (SYSCR).....	595
17.3	Operation	596
Section 18	Flash Memory	597
18.1	Overview.....	597
18.2	Features.....	598
18.2.1	Block Diagram.....	599
18.2.2	Pin Configuration	600
18.2.3	Register Configuration.....	600
18.3	Register Descriptions.....	601
18.3.1	Flash Memory Control Register 1 (FLMCR1)	601
18.3.2	Flash Memory Control Register 2 (FLMCR2)	604
18.3.3	Erase Block Register 1 (EBR1)	605
18.3.4	Erase Block Register 2 (EBR2)	606
18.3.5	RAM Control Register (RAMCR).....	607
18.4	Overview of Operation	609
18.4.1	Mode Transitions	609
18.4.2	On-Board Programming Modes.....	611
18.4.3	Flash Memory Emulation in RAM	613
18.4.4	Block Configuration	615
18.5	On-Board Programming Mode	616
18.5.1	Boot Mode	617
18.5.2	User Program Mode.....	622
18.6	Flash Memory Programming/Erasing.....	624
18.6.1	Program Mode	626
18.6.2	Program-Verify Mode	627
18.6.3	Erase Mode.....	631
18.6.4	Erase-Verify Mode	631
18.7	Flash Memory Protection.....	633
18.7.1	Hardware Protection	633
18.7.2	Software Protection	634
18.7.3	Error Protection	635
18.8	Flash Memory Emulation in RAM	637
18.9	NMI Input Disabling Conditions	640
18.10	Flash Memory PROM Mode	641
18.10.1	Socket Adapters and Memory Map	641

18.10.2	Notes on Use of PROM Mode.....	642
18.11	Flash Memory Programming and Erasing Precautions.....	643
Section 19	Clock Pulse Generator.....	649
19.1	Overview.....	649
19.1.1	Block Diagram.....	650
19.2	Oscillator Circuit.....	651
19.2.1	Connecting a Crystal Resonator.....	651
19.2.2	External Clock Input.....	653
19.3	Duty Adjustment Circuit.....	655
19.4	Prescalers.....	655
19.5	Frequency Divider.....	656
19.5.1	Register Configuration.....	656
19.5.2	Division Control Register (DIVCR).....	656
19.5.3	Usage Notes.....	657
Section 20	Power-Down State.....	659
20.1	Overview.....	659
20.2	Register Configuration.....	661
20.2.1	System Control Register (SYSCR).....	661
20.2.2	Module Standby Control Register H (MSTCRH).....	663
20.2.3	Module Standby Control Register L (MSTCRL).....	664
20.3	Sleep Mode.....	667
20.3.1	Transition to Sleep Mode.....	667
20.3.2	Exit from Sleep Mode.....	667
20.4	Software Standby Mode.....	668
20.4.1	Transition to Software Standby Mode.....	668
20.4.2	Exit from Software Standby Mode.....	668
20.4.3	Selection of Waiting Time for Exit from Software Standby Mode.....	669
20.4.4	Sample Application of Software Standby Mode.....	670
20.4.5	Note.....	670
20.5	Hardware Standby Mode.....	671
20.5.1	Transition to Hardware Standby Mode.....	671
20.5.2	Exit from Hardware Standby Mode.....	671
20.5.3	Timing for Hardware Standby Mode.....	671
20.6	Module Standby Function.....	673
20.6.1	Module Standby Timing.....	673
20.6.2	Read/Write in Module Standby.....	673
20.6.3	Usage Notes.....	673
20.7	System Clock Output Disabling Function.....	674

Section 21	Electrical Characteristics	675
21.1	Electrical Characteristics of H8/3068F-ZTAT.....	675
21.1.1	Absolute Maximum Ratings	675
21.1.2	DC Characteristics	676
21.1.3	AC Characteristics	681
21.1.4	A/D Conversion Characteristics	687
21.1.5	D/A Conversion Characteristics	689
21.1.6	Flash Memory Characteristics	690
21.2	Operational Timing.....	692
21.2.1	Clock Timing.....	692
21.2.2	Control Signal Timing	693
21.2.3	Bus Timing	694
21.2.4	DRAM Interface Bus Timing	700
21.2.5	TPC and I/O Port Timing.....	703
21.2.6	Timer Input/Output Timing	704
21.2.7	SCI Input/Output Timing.....	705
21.2.8	DMAC Timing.....	706
Appendix A	Instruction Set.....	707
A.1	Instruction List.....	707
A.2	Operation Code Maps	723
A.3	Number of States Required for Execution	726
Appendix B	Internal I/O Registers	735
B.1	Addresses (EMC = 1)	735
B.2	Addresses (EMC = 0)	746
B.3	Functions	763
Appendix C	I/O Port Block Diagrams	854
C.1	Port 1 Block Diagram	854
C.2	Port 2 Block Diagram	855
C.3	Port 3 Block Diagram	856
C.4	Port 4 Block Diagram	857
C.5	Port 5 Block Diagram	858
C.6	Port 6 Block Diagrams.....	859
C.7	Port 7 Block Diagrams.....	866
C.8	Port 8 Block Diagrams.....	867
C.9	Port 9 Block Diagrams.....	872
C.10	Port A Block Diagrams.....	878
C.11	Port B Block Diagrams	881

Appendix D	Pin States	889
D.1	Port States in Each Mode	889
D.2	Pin States at Reset.....	896
Appendix E	Timing of Transition to and Recovery from Hardware Standby Mode	899
Appendix F	Product Code Lineup.....	900
Appendix G	Package Dimensions.....	901
Appendix H	Comparison of H8/300H Series Product Specifications.....	903
H.1	Differences between H8/3068F and H8/3067 Group and H8/3062 Group, H8/3048 Group	903
H.2	Comparison of Pin Functions of 100-Pin Package Products (FP-100B, TFP-100B).....	906

Section 1 Overview

1.1 Overview

The H8/3068F is a series of microcontrollers (MCUs) that integrate system supporting functions together with an H8/300H CPU core having an original Renesas Technology architecture.

The H8/300H CPU has a 32-bit internal architecture with sixteen 16-bit general registers, and a concise, optimized instruction set designed for speed. It can address a 16-Mbyte linear address space. Its instruction set is upward-compatible at the object-code level with the H8/300 CPU, enabling easy porting of software from the H8/300 Series.

The on-chip system supporting functions include ROM, RAM, a 16-bit timer, an 8-bit timer, a programmable timing pattern controller (TPC), a watchdog timer (WDT), a serial communication interface (SCI), an A/D converter, a D/A converter, I/O ports, a direct memory access controller (DMAC), and other facilities.

The H8/3068F has 384 kbytes of ROM and 16 kbytes of RAM.

Seven MCU operating modes offer a choice of bus width and address space size. The modes (modes 1 to 7) include two single-chip modes and five expanded modes.

The H8/3068F includes an F-ZTAT™* version with on-chip flash memory that can be programmed on-board. This version enables users to respond quickly and flexibly to changing application specifications, growing production volumes, and other conditions.

Table 1.1 summarizes the features of the H8/3068F.

Note: * F-ZTAT™ (Flexible ZTAT) is a trademark of Renesas Technology Corp.

Table 1.1 Features

Feature	Description
CPU	<p>Upward-compatible with the H8/300 CPU at the object-code level General-register machine</p> <ul style="list-style-type: none"> Sixteen 16-bit general registers (also usable as sixteen 8-bit registers or eight 32-bit registers) <p>High-speed operation</p> <ul style="list-style-type: none"> Maximum clock rate: 25 MHz Add/subtract: 80 ns Multiply/divide: 560 ns <p>16-Mbyte address space</p> <p>Instruction features</p> <ul style="list-style-type: none"> 8/16/32-bit data transfer, arithmetic, and logic instructions Signed and unsigned multiply instructions (8 bits x 8 bits, 16 bits x 16 bits) Signed and unsigned divide instructions (16 bits ÷ 8 bits, 32 bits ÷ 16 bits) Bit accumulator function Bit manipulation instructions with register-indirect specification of bit positions
Memory	<p>H8/3068F</p> <ul style="list-style-type: none"> ROM: 384 kbytes RAM: 16 kbytes
Interrupt controller	<ul style="list-style-type: none"> Seven external interrupt pins: NMI, \overline{IRQ}_0 to \overline{IRQ}_5 36 internal interrupts Three selectable interrupt priority levels
Bus controller	<ul style="list-style-type: none"> Address space can be partitioned into eight areas, with independent bus specifications in each area Chip select output available for areas 0 to 7 8-bit access or 16-bit access selectable for each area Two-state or three-state access selectable for each area Selection of two wait modes Number of program wait states selectable for each area Direct connection of burst ROM Direct connection of up to 8-Mbyte DRAM (or DRAM interface can be used as interval timer) Bus arbitration function

Feature	Description
DMA controller (DMAC)	<p>Short address mode</p> <ul style="list-style-type: none"> • Maximum four channels available • Selection of I/O mode, idle mode, or repeat mode • Can be activated by compare match/input capture A interrupts from 16-bit timer channels 0 to 2, conversion-end interrupts from the A/D converter, transmit-data-empty and receive-data-full interrupts from the SCI, or external requests <p>Full address mode</p> <ul style="list-style-type: none"> • Maximum two channels available • Selection of normal mode or block transfer mode • Can be activated by compare match/input capture A interrupts from 16-bit timer channels 0 to 2, conversion-end interrupts from the A/D converter, external requests, or auto-request
16-bit timer, 3 channels	<ul style="list-style-type: none"> • Three 16-bit timer channels, capable of processing up to six pulse outputs or six pulse inputs • 16-bit timer counter (channels 0 to 2) • Two multiplexed output compare/input capture pins (channels 0 to 2) • Operation can be synchronized (channels 0 to 2) • PWM mode available (channels 0 to 2) • Phase counting mode available (channel 2) • DMAC can be activated by compare match/input capture A interrupts (channels 0 to 2)
8-bit timer, 4 channels	<ul style="list-style-type: none"> • 8-bit up-counter (external event count capability) • Two time constant registers • Two channels can be connected
Programmable timing pattern controller (TPC)	<ul style="list-style-type: none"> • Maximum 16-bit pulse output, using 16-bit timer as time base • Up to four 4-bit pulse output groups (or one 16-bit group, or two 8-bit groups) • Non-overlap mode available • Output data can be transferred by DMAC
Watchdog timer (WDT), 1 channel	<ul style="list-style-type: none"> • Reset signal can be generated by overflow • Reset signal can be output externally (not in the F-ZTAT version) • Usable as an interval timer

Feature	Description																																								
Serial communication interface (SCI), 3 channels	<ul style="list-style-type: none"> • Selection of asynchronous or synchronous mode • Full duplex: can transmit and receive simultaneously • On-chip baud-rate generator • Smart card interface functions added 																																								
A/D converter	<ul style="list-style-type: none"> • Resolution: 10 bits • Eight channels, with selection of single or scan mode • Variable analog conversion voltage range • Sample-and-hold function • A/D conversion can be started by an external trigger or 8-bit timer compare-match • DMAC can be activated by an A/D conversion end interrupt 																																								
D/A converter	<ul style="list-style-type: none"> • Resolution: 8 bits • Two channels • D/A outputs can be sustained in software standby mode 																																								
I/O ports	<ul style="list-style-type: none"> • 70 input/output pins • 9 input-only pins 																																								
Operating modes	<ul style="list-style-type: none"> • Seven MCU operating modes <table border="1"> <thead> <tr> <th>Mode</th> <th>Address Space</th> <th>Address Pins</th> <th>Initial Bus Width</th> <th>Max. Bus Width</th> </tr> </thead> <tbody> <tr> <td>Mode 1</td> <td>1 Mbyte</td> <td>A₁₉ to A₀</td> <td>8 bits</td> <td>16 bits</td> </tr> <tr> <td>Mode 2</td> <td>1 Mbyte</td> <td>A₁₉ to A₀</td> <td>16 bits</td> <td>16 bits</td> </tr> <tr> <td>Mode 3</td> <td>16 Mbytes</td> <td>A₂₃ to A₀</td> <td>8 bits</td> <td>16 bits</td> </tr> <tr> <td>Mode 4</td> <td>16 Mbytes</td> <td>A₂₃ to A₀</td> <td>16 bits</td> <td>16 bits</td> </tr> <tr> <td>Mode 5</td> <td>16 Mbytes</td> <td>A₂₃ to A₀</td> <td>8 bits</td> <td>16 bits</td> </tr> <tr> <td>Mode 6</td> <td>64 kbyte</td> <td>—</td> <td>—</td> <td>—</td> </tr> <tr> <td>Mode 7</td> <td>1 Mbyte</td> <td>—</td> <td>—</td> <td>—</td> </tr> </tbody> </table> <ul style="list-style-type: none"> • On-chip ROM is disabled in modes 1 to 4 	Mode	Address Space	Address Pins	Initial Bus Width	Max. Bus Width	Mode 1	1 Mbyte	A ₁₉ to A ₀	8 bits	16 bits	Mode 2	1 Mbyte	A ₁₉ to A ₀	16 bits	16 bits	Mode 3	16 Mbytes	A ₂₃ to A ₀	8 bits	16 bits	Mode 4	16 Mbytes	A ₂₃ to A ₀	16 bits	16 bits	Mode 5	16 Mbytes	A ₂₃ to A ₀	8 bits	16 bits	Mode 6	64 kbyte	—	—	—	Mode 7	1 Mbyte	—	—	—
Mode	Address Space	Address Pins	Initial Bus Width	Max. Bus Width																																					
Mode 1	1 Mbyte	A ₁₉ to A ₀	8 bits	16 bits																																					
Mode 2	1 Mbyte	A ₁₉ to A ₀	16 bits	16 bits																																					
Mode 3	16 Mbytes	A ₂₃ to A ₀	8 bits	16 bits																																					
Mode 4	16 Mbytes	A ₂₃ to A ₀	16 bits	16 bits																																					
Mode 5	16 Mbytes	A ₂₃ to A ₀	8 bits	16 bits																																					
Mode 6	64 kbyte	—	—	—																																					
Mode 7	1 Mbyte	—	—	—																																					
Power-down state	<ul style="list-style-type: none"> • Sleep mode • Software standby mode • Hardware standby mode • Module standby function • Programmable system clock frequency division 																																								
Other features	<ul style="list-style-type: none"> • On-chip clock pulse generator 																																								

Feature	Description		
Product lineup	Product Type	Product Code	Package
	H8/3068 F-ZTAT 5 V operation	HD64F3068F	100-pin QFP (FP-100B)
		HD64F3068TE	100-pin TQFP (TFP-100B)

1.2 Block Diagram

Figure 1.1 shows an internal block diagram.

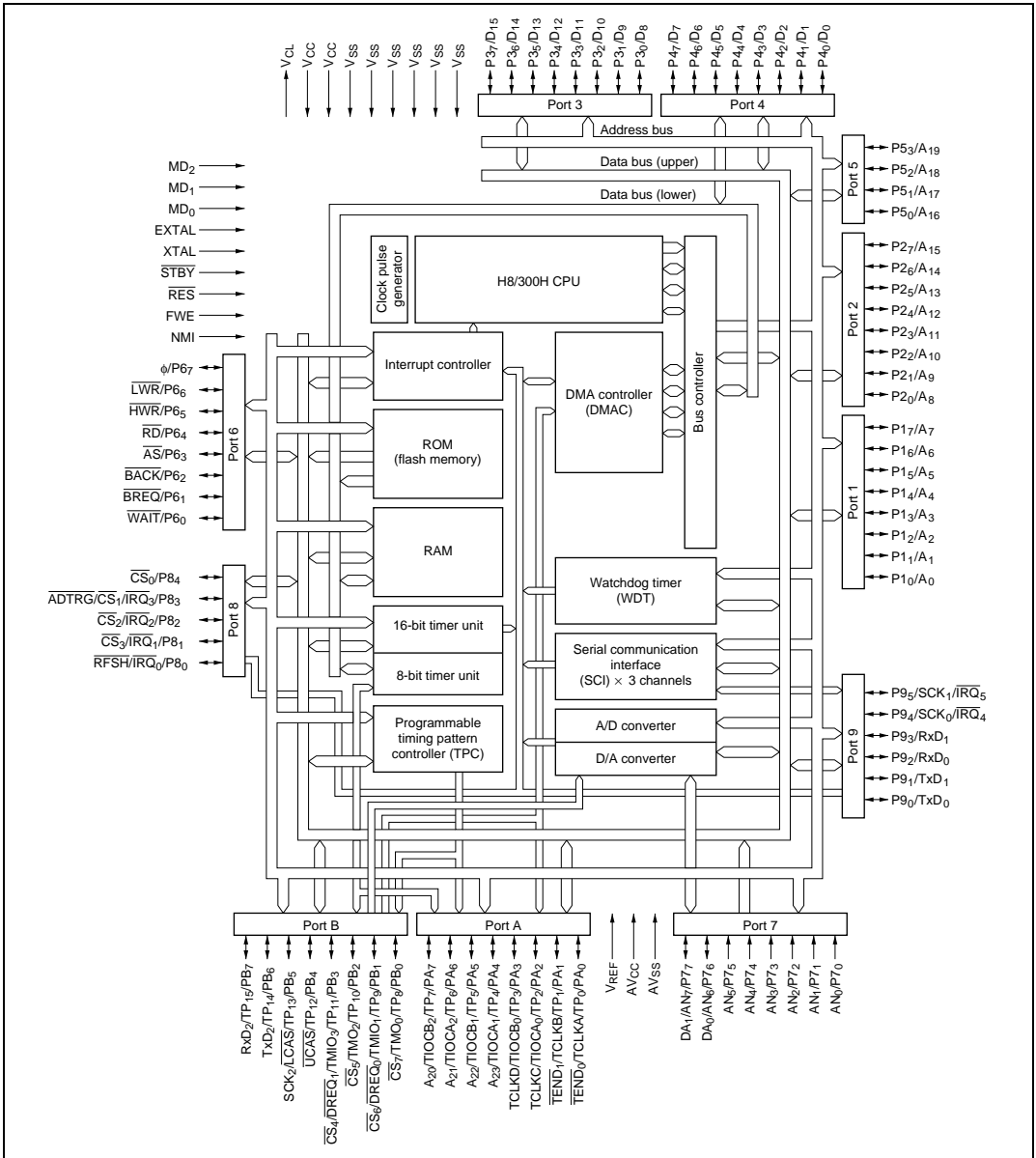

Figure 1.1 Block Diagram

1.3 Pin Description

1.3.1 Pin Arrangement

The pin arrangement of the H8/3068F FP-100B and TFP-100B packages is shown in figure 1.2.

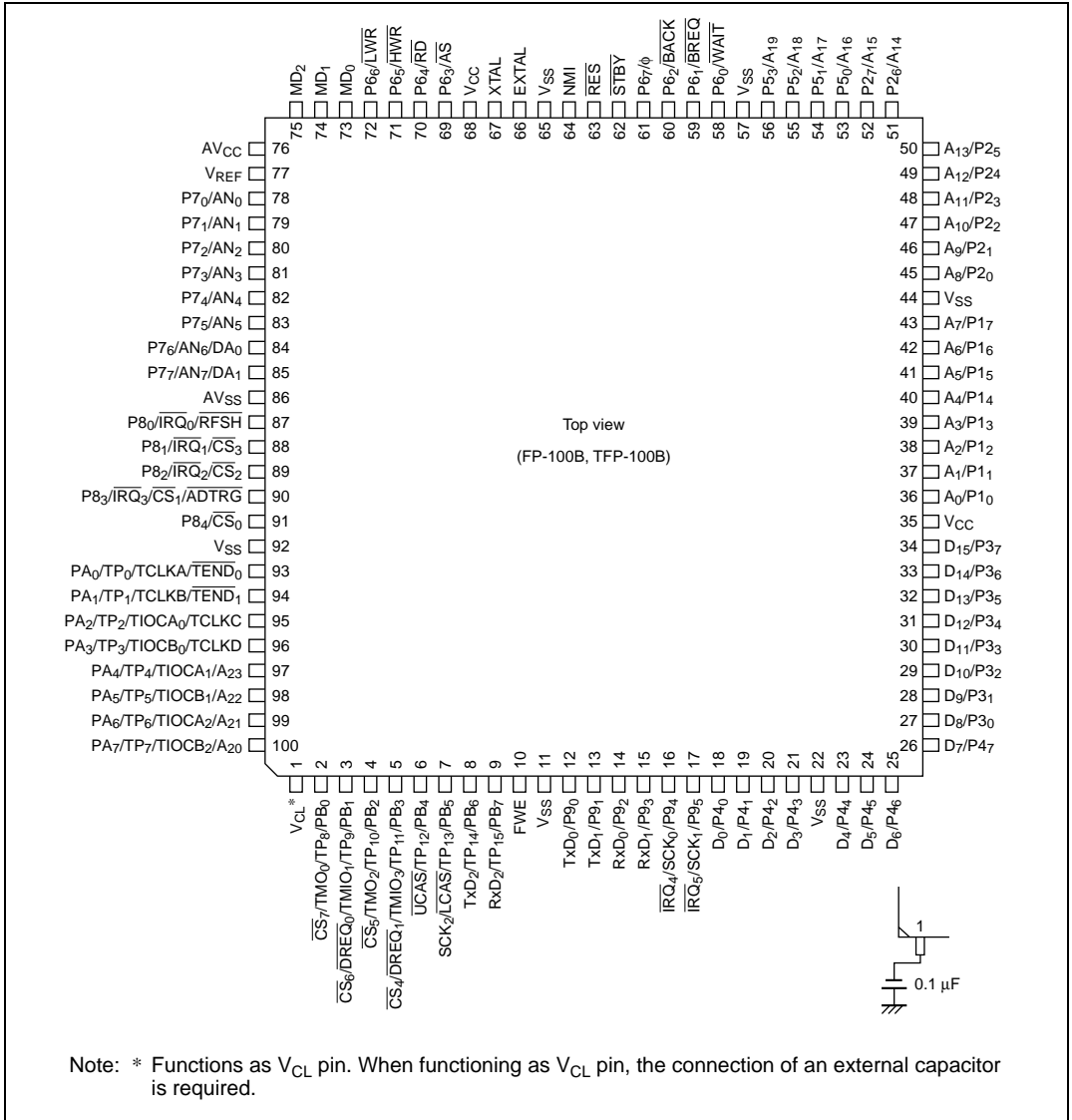
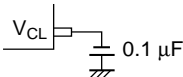

Figure 1.2 Pin Arrangement (FP-100B or TFP-100B, Top View)

1.3.2 Pin Functions

Table 1.2 summarizes the pin functions.

Table 1.2 Pin Functions

Type	Symbol	Pin No.		Name and Function			
		FP-100B	TFP-100B I/O				
Power	V_{CC}	35, 68	Input	Power: For connection to the power supply. Connect all V_{CC} pins to the system power supply.			
	V_{SS}	11, 22, 44, 57, 65, 92	Input	Ground: For connection to ground (0 V). Connect all V_{SS} pins to the 0-V system power supply.			
Clock	XTAL	67	Input	For connection to a crystal resonator. For examples of crystal resonator and external clock input, see section 19, Clock Pulse Generator.			
	EXTAL	66	Input	For connection to a crystal resonator or input of an external clock signal. For examples of crystal resonator and external clock input, see section 19, Clock Pulse Generator.			
	ϕ	61	Output	System clock: Supplies the system clock to external devices.			
Internal step-down pin	V_{CL}	1	Output	Connect an external capacitor between this pin and GND (0 V). Do not connect to V_{CC} . 			
Operating mode control	MD_2 to MD_0	75 to 73	Input	Mode 2 to mode 0: For setting the operating mode, as follows. Inputs at these pins must not be changed during operation.			
				MD_2	MD_1	MD_0	Operating Mode
				0	0	0	—
				0	0	1	Mode 1
				0	1	0	Mode 2
				0	1	1	Mode 3
				1	0	0	Mode 4
				1	0	1	Mode 5
				1	1	0	Mode 6
1	1	1	Mode 7				

Type	Symbol	Pin No.		Name and Function
		FP-100B	TFP-100B	
System control	$\overline{\text{RES}}$	63	Input	Reset input: When driven low, this pin resets the chip
	$\overline{\text{FWE}}$	10	Input	Write enable signal: Flash memory write control signal
	$\overline{\text{STBY}}$	62	Input	Standby: When driven low, this pin forces a transition to hardware standby mode
	$\overline{\text{BREQ}}$	59	Input	Bus request: Used by an external bus master to request the bus right
	$\overline{\text{BACK}}$	60	Output	Bus request acknowledge: Indicates that the bus has been granted to an external bus master
Interrupts	NMI	64	Input	Nonmaskable interrupt: Requests a nonmaskable interrupt
	$\overline{\text{IRQ}}_5$ to $\overline{\text{IRQ}}_0$	17, 16, 90 to 87	Input	Interrupt request 5 to 0: Maskable interrupt request pins
Address bus	A_{23} to A_0	97 to 100, 56 to 45, 43 to 36	Output	Address bus: Outputs address signals
Data bus	D_{15} to D_0	34 to 23, 21 to 18	Input/output	Data bus: Bidirectional data bus
Bus control	$\overline{\text{CS}}_7$ to $\overline{\text{CS}}_0$	2 to 5, 88 to 91	Output	Chip select: Select signals for areas 7 to 0
	$\overline{\text{AS}}$	69	Output	Address strobe: Goes low to indicate valid address output on the address bus
	$\overline{\text{RD}}$	70	Output	Read: Goes low to indicate reading from the external address space
	$\overline{\text{HWR}}$	71	Output	High write: Goes low to indicate writing to the external address space; indicates valid data on the upper data bus (D_{15} to D_8).
	$\overline{\text{LWR}}$	72	Output	Low write: Goes low to indicate writing to the external address space; indicates valid data on the lower data bus (D_7 to D_0).
	$\overline{\text{WAIT}}$	58	Input	Wait: Requests insertion of wait states in bus cycles during access to the external address space

Type	Symbol	Pin No.		Name and Function
		FP-100B	I/O	
DRAM interface	$\overline{\text{RFSH}}$	87	Output	Refresh: Indicates a refresh cycle
	$\overline{\text{CS}}_2$ to $\overline{\text{CS}}_5$	89, 88, 5, 4	Output	Row address strobe $\overline{\text{RAS}}$: Row address strobe signal for DRAM
	$\overline{\text{RD}}$	70	Output	Write enable $\overline{\text{WE}}$: Write enable signal for DRAM
	$\overline{\text{HWR}}$ $\overline{\text{UCAS}}$	71 6	Output	Upper column address strobe $\overline{\text{UCAS}}$: Column address strobe signal for DRAM
	$\overline{\text{LWR}}$ $\overline{\text{LCAS}}$	72 7	Output	Lower column address strobe $\overline{\text{LCAS}}$: Column address strobe signal for DRAM
DMA controller (DMAC)	$\overline{\text{DREQ}}_1$, $\overline{\text{DREQ}}_0$	5, 3	Input	DMA request 1 and 0: DMAC activation requests
	$\overline{\text{TEND}}_1$, $\overline{\text{TEND}}_0$	94, 93	Output	Transfer end 1 and 0: These signals indicate that the DMAC has ended a data transfer
16-bit timer	TCLKD to TCLKA	96 to 93	Input	Clock input D to A: External clock inputs
	TIOCA ₂ to TIOCA ₀	99, 97, 95	Input/ output	Input capture/output compare A2 to A0: GRA2 to GRA0 output compare or input capture, or PWM output
	TIOCB ₂ to TIOCB ₀	100, 98, 96	Input/ output	Input capture/output compare B2 to B0: GRB2 to GRB0 output compare or input capture, or PWM output
8-bit timer	TMO ₀ , TMO ₂	2, 4	Output	Compare match output: Compare match output pins
	TMIO ₁ , TMIO ₃	3, 5	Input/ output	Input capture input/compare match output: Input capture input or compare match output pins
	TCLKD to TCLKA	96 to 93	Input	Counter external clock input: These pins input an external clock to the counters.
Program- mable timing pattern controller (TPC)	TP ₁₅ to TP ₀	9 to 2, 100 to 93	Output	TPC output 15 to 0: Pulse output

Type	Symbol	Pin No.		I/O	Name and Function
		FP-100B	TFP-100B		
Serial communication interface (SCI)	TxD ₂ to TxD ₀	8, 13, 12		Output	Transmit data (channels 0, 1, 2): SCI data output
	RxD ₂ to RxD ₀	9, 15, 14		Input	Receive data (channels 0, 1, 2): SCI data input
	SCK ₂ to SCK ₀	7, 17, 16		Input/output	Serial clock (channels 0, 1, 2): SCI clock input/output
A/D converter	AN ₇ to AN ₀	85 to 78		Input	Analog 7 to 0: Analog input pins
	ADTRG	90		Input	A/D conversion external trigger input: External trigger input for starting A/D conversion
D/A converter	DA ₁ , DA ₀	85, 84		Output	Analog output: Analog output from the D/A converter
A/D and D/A converters	AV _{CC}	76		Input	Power supply pin for the A/D and D/A converters. Connect to the system power supply when not using the A/D and D/A converters.
	AV _{SS}	86		Input	Ground pin for the A/D and D/A converters. Connect to system ground (0 V).
	V _{REF}	77		Input	Reference voltage input pin for the A/D and D/A converters. Connect to the system power supply when not using the A/D and D/A converters.
I/O ports	P1 ₇ to P1 ₀	43 to 36		Input/output	Port 1: Eight input/output pins. The direction of each pin can be selected in the port 1 data direction register (P1DDR).
	P2 ₇ to P2 ₀	52 to 45		Input/output	Port 2: Eight input/output pins. The direction of each pin can be selected in the port 2 data direction register (P2DDR).
	P3 ₇ to P3 ₀	34 to 27		Input/output	Port 3: Eight input/output pins. The direction of each pin can be selected in the port 3 data direction register (P3DDR).
	P4 ₇ to P4 ₀	26 to 23, 21 to 18		Input/output	Port 4: Eight input/output pins. The direction of each pin can be selected in the port 4 data direction register (P4DDR).
	P5 ₃ to P5 ₀	56 to 53		Input/output	Port 5: Four input/output pins. The direction of each pin can be selected in the port 5 data direction register (P5DDR).

Type	Symbol	Pin No.		Name and Function
		FP-100B	I/O	
I/O ports	P6 ₇ to P6 ₀	61, 72 to 69, 60 to 58	Input/ output	Port 6: Eight input/output pins. The direction of each pin can be selected in the port 6 data direction register (P6DDR).
	P7 ₇ to P7 ₀	85 to 78	Input	Port 7: Eight input pins
	P8 ₄ to P8 ₀	91 to 87	Input/ output	Port 8: Five input/output pins. The direction of each pin can be selected in the port 8 data direction register (P8DDR).
	P9 ₅ to P9 ₀	17 to 12	Input/ output	Port 9: Six input/output pins. The direction of each pin can be selected in the port 9 data direction register (P9DDR).
	PA ₇ to PA ₀	100 to 93	Input/ output	Port A: Eight input/output pins. The direction of each pin can be selected in the port A data direction register (PADDR).
	PB ₇ to PB ₀	9 to 2	Input/ output	Port B: Eight input/output pins. The direction of each pin can be selected in the port B data direction register (PBDDR).

1.3.3 Pin Assignments in Each Mode

Table 1.3 lists the pin assignments in each mode.

Table 1.3 Pin Assignments in Each Mode (FP-100B or TFP-100B)

Pin No.	Pin Name						
	Mode 1	Mode 2	Mode 3	Mode 4	Mode 5	Mode 6	Mode 7
1	V_{CL}^{*1}	V_{CL}^{*1}	V_{CL}^{*1}	V_{CL}^{*1}	V_{CL}^{*1}	V_{CL}^{*1}	V_{CL}^{*1}
2	PB ₀ /TP ₈ / TMO ₀ / \overline{CS}_7	PB ₀ /TP ₈ / TMO ₀ / \overline{CS}_7	PB ₀ /TP ₈ / TMO ₀ / \overline{CS}_7	PB ₀ /TP ₈ / TMO ₀ / \overline{CS}_7	PB ₀ /TP ₈ / TMO ₀ / \overline{CS}_7	PB ₀ /TP ₈ / TMO ₀	PB ₀ /TP ₈ / TMO ₀
3	PB ₁ /TP ₉ / TMIO ₁ / \overline{DREQ}_0 / \overline{CS}_6	PB ₁ /TP ₉ / TMIO ₁ / \overline{DREQ}_0 / \overline{CS}_6	PB ₁ /TP ₉ / TMIO ₁ / \overline{DREQ}_0 / \overline{CS}_6	PB ₁ /TP ₉ / TMIO ₁ / \overline{DREQ}_0 / \overline{CS}_6	PB ₁ /TP ₉ / TMIO ₁ / \overline{DREQ}_0 / \overline{CS}_6	PB ₁ /TP ₉ / TMIO ₁ / \overline{DREQ}_0	PB ₁ /TP ₉ / TMIO ₁ / \overline{DREQ}_0
4	PB ₂ /TP ₁₀ / TMO ₂ / \overline{CS}_5	PB ₂ /TP ₁₀ / TMO ₂ / \overline{CS}_5	PB ₂ /TP ₁₀ / TMO ₂ / \overline{CS}_5	PB ₂ /TP ₁₀ / TMO ₂ / \overline{CS}_5	PB ₂ /TP ₁₀ / TMO ₂ / \overline{CS}_5	PB ₂ /TP ₁₀ / TMO ₂	PB ₂ /TP ₁₀ / TMO ₂
5	PB ₃ /TP ₁₁ / TMIO ₃ / \overline{DREQ}_1 / CS ₄	PB ₃ /TP ₁₁ / TMIO ₃ / \overline{DREQ}_1 / CS ₄	PB ₃ /TP ₁₁ / TMIO ₃ / \overline{DREQ}_1 / CS ₄	PB ₃ /TP ₁₁ / TMIO ₃ / \overline{DREQ}_1 / CS ₄	PB ₃ /TP ₁₁ / TMIO ₃ / \overline{DREQ}_1 / CS ₄	PB ₃ /TP ₁₁ / TMIO ₃ / \overline{DREQ}_1	PB ₃ /TP ₁₁ / TMIO ₃ / \overline{DREQ}_1
6	PB ₄ /TP ₁₂ / UCAS	PB ₄ /TP ₁₂ / UCAS	PB ₄ /TP ₁₂ / UCAS	PB ₄ /TP ₁₂ / UCAS	PB ₄ /TP ₁₂ / UCAS	PB ₄ /TP ₁₂	PB ₄ /TP ₁₂
7	PB ₅ /TP ₁₃ / LCAS/ SCK ₂	PB ₅ /TP ₁₃ / LCAS/ SCK ₂	PB ₅ /TP ₁₃ / LCAS/ SCK ₂	PB ₅ /TP ₁₃ / LCAS/ SCK ₂	PB ₅ /TP ₁₃ / LCAS/ SCK ₂	PB ₅ /TP ₁₃ / SCK ₂	PB ₅ /TP ₁₃ / SCK ₂
8	PB ₆ /TP ₁₄ / TxD ₂	PB ₆ /TP ₁₄ / TxD ₂	PB ₆ /TP ₁₄ / TxD ₂	PB ₆ /TP ₁₄ / TxD ₂	PB ₆ /TP ₁₄ / TxD ₂	PB ₆ /TP ₁₄ / TxD ₂	PB ₆ /TP ₁₄ / TxD ₂
9	PB ₇ /TP ₁₅ / RxD ₂	PB ₇ /TP ₁₅ / RxD ₂	PB ₇ /TP ₁₅ / RxD ₂	PB ₇ /TP ₁₅ / RxD ₂	PB ₇ /TP ₁₅ / RxD ₂	PB ₇ /TP ₁₅ / RxD ₂	PB ₇ /TP ₁₅ / RxD ₂
10	FWE	FWE	FWE	FWE	FWE	FWE	FWE
11	V _{SS}	V _{SS}	V _{SS}	V _{SS}	V _{SS}	V _{SS}	V _{SS}
12	P9 ₀ /TxD ₀	P9 ₀ /TxD ₀	P9 ₀ /TxD ₀	P9 ₀ /TxD ₀	P9 ₀ /TxD ₀	P9 ₀ /TxD ₀	P9 ₀ /TxD ₀
13	P9 ₁ /TxD ₁	P9 ₁ /TxD ₁	P9 ₁ /TxD ₁	P9 ₁ /TxD ₁	P9 ₁ /TxD ₁	P9 ₁ /TxD ₁	P9 ₁ /TxD ₁
14	P9 ₂ /RxD ₀	P9 ₂ /RxD ₀	P9 ₂ /RxD ₀	P9 ₂ /RxD ₀	P9 ₂ /RxD ₀	P9 ₂ /RxD ₀	P9 ₂ /RxD ₀
15	P9 ₃ /RxD ₁	P9 ₃ /RxD ₁	P9 ₃ /RxD ₁	P9 ₃ /RxD ₁	P9 ₃ /RxD ₁	P9 ₃ /RxD ₁	P9 ₃ /RxD ₁
16	P9 ₄ / \overline{IRQ}_4 / SCK ₀	P9 ₄ / \overline{IRQ}_4 / SCK ₀	P9 ₄ / \overline{IRQ}_4 / SCK ₀	P9 ₄ / \overline{IRQ}_4 / SCK ₀	P9 ₄ / \overline{IRQ}_4 / SCK ₀	P9 ₄ / \overline{IRQ}_4 / SCK ₀	P9 ₄ / \overline{IRQ}_4 / SCK ₀

Pin No.	Pin Name						
FP-100B TFP-100B	Mode 1	Mode 2	Mode 3	Mode 4	Mode 5	Mode 6	Mode 7
17	P9 ₅ /IRQ ₅ / SCK ₁	P9 ₅ /IRQ ₅ / SCK ₁	P9 ₅ /IRQ ₅ / SCK ₁	P9 ₅ /IRQ ₅ / SCK ₁	P9 ₅ /IRQ ₅ / SCK ₁	P9 ₅ /IRQ ₅ / SCK ₁	P9 ₅ /IRQ ₅ / SCK ₁
18	P4 ₀ /D ₀ * ²	P4 ₀ /D ₀ * ³	P4 ₀ /D ₀ * ²	P4 ₀ /D ₀ * ³	P4 ₀ /D ₀ * ²	P4 ₀	P4 ₀
19	P4 ₁ /D ₁ * ²	P4 ₁ /D ₁ * ³	P4 ₁ /D ₁ * ²	P4 ₁ /D ₁ * ³	P4 ₁ /D ₁ * ²	P4 ₁	P4 ₁
20	P4 ₂ /D ₂ * ²	P4 ₂ /D ₂ * ³	P4 ₂ /D ₂ * ²	P4 ₂ /D ₂ * ³	P4 ₂ /D ₂ * ²	P4 ₂	P4 ₂
21	P4 ₃ /D ₃ * ²	P4 ₃ /D ₃ * ³	P4 ₃ /D ₃ * ²	P4 ₃ /D ₃ * ³	P4 ₃ /D ₃ * ²	P4 ₃	P4 ₃
22	V _{SS}	V _{SS}	V _{SS}	V _{SS}	V _{SS}	V _{SS}	V _{SS}
23	P4 ₄ /D ₄ * ²	P4 ₄ /D ₄ * ³	P4 ₄ /D ₄ * ²	P4 ₄ /D ₄ * ³	P4 ₄ /D ₄ * ²	P4 ₄	P4 ₄
24	P4 ₅ /D ₅ * ²	P4 ₅ /D ₅ * ³	P4 ₅ /D ₅ * ²	P4 ₅ /D ₅ * ³	P4 ₅ /D ₅ * ²	P4 ₅	P4 ₅
25	P4 ₆ /D ₆ * ²	P4 ₆ /D ₆ * ³	P4 ₆ /D ₆ * ²	P4 ₆ /D ₆ * ³	P4 ₆ /D ₆ * ²	P4 ₆	P4 ₆
26	P4 ₇ /D ₇ * ²	P4 ₇ /D ₇ * ³	P4 ₇ /D ₇ * ²	P4 ₇ /D ₇ * ³	P4 ₇ /D ₇ * ²	P4 ₇	P4 ₇
27	D ₈	D ₈	D ₈	D ₈	D ₈	P3 ₀	P3 ₀
28	D ₉	D ₉	D ₉	D ₉	D ₉	P3 ₁	P3 ₁
29	D ₁₀	D ₁₀	D ₁₀	D ₁₀	D ₁₀	P3 ₂	P3 ₂
30	D ₁₁	D ₁₁	D ₁₁	D ₁₁	D ₁₁	P3 ₃	P3 ₃
31	D ₁₂	D ₁₂	D ₁₂	D ₁₂	D ₁₂	P3 ₄	P3 ₄
32	D ₁₃	D ₁₃	D ₁₃	D ₁₃	D ₁₃	P3 ₅	P3 ₅
33	D ₁₄	D ₁₄	D ₁₄	D ₁₄	D ₁₄	P3 ₆	P3 ₆
34	D ₁₅	D ₁₅	D ₁₅	D ₁₅	D ₁₅	P3 ₇	P3 ₇
35	V _{CC}	V _{CC}	V _{CC}	V _{CC}	V _{CC}	V _{CC}	V _{CC}
36	A ₀	A ₀	A ₀	A ₀	P1 ₀ /A ₀	P1 ₀	P1 ₀
37	A ₁	A ₁	A ₁	A ₁	P1 ₁ /A ₁	P1 ₁	P1 ₁
38	A ₂	A ₂	A ₂	A ₂	P1 ₂ /A ₂	P1 ₂	P1 ₂
39	A ₃	A ₃	A ₃	A ₃	P1 ₃ /A ₃	P1 ₃	P1 ₃
40	A ₄	A ₄	A ₄	A ₄	P1 ₄ /A ₄	P1 ₄	P1 ₄
41	A ₅	A ₅	A ₅	A ₅	P1 ₅ /A ₅	P1 ₅	P1 ₅
42	A ₆	A ₆	A ₆	A ₆	P1 ₆ /A ₆	P1 ₆	P1 ₆
43	A ₇	A ₇	A ₇	A ₇	P1 ₇ /A ₇	P1 ₇	P1 ₇
44	V _{SS}	V _{SS}	V _{SS}	V _{SS}	V _{SS}	V _{SS}	V _{SS}
45	A ₈	A ₈	A ₈	A ₈	P2 ₀ /A ₈	P2 ₀	P2 ₀
46	A ₉	A ₉	A ₉	A ₉	P2 ₁ /A ₉	P2 ₁	P2 ₁
47	A ₁₀	A ₁₀	A ₁₀	A ₁₀	P2 ₂ /A ₁₀	P2 ₂	P2 ₂

Pin No.	Pin Name						
FP-100B TFP-100B	Mode 1	Mode 2	Mode 3	Mode 4	Mode 5	Mode 6	Mode 7
48	A ₁₁	A ₁₁	A ₁₁	A ₁₁	P2 ₃ /A ₁₁	P2 ₃	P2 ₃
49	A ₁₂	A ₁₂	A ₁₂	A ₁₂	P2 ₄ /A ₁₂	P2 ₄	P2 ₄
50	A ₁₃	A ₁₃	A ₁₃	A ₁₃	P2 ₅ /A ₁₃	P2 ₅	P2 ₅
51	A ₁₄	A ₁₄	A ₁₄	A ₁₄	P2 ₆ /A ₁₄	P2 ₆	P2 ₆
52	A ₁₅	A ₁₅	A ₁₅	A ₁₅	P2 ₇ /A ₁₅	P2 ₇	P2 ₇
53	A ₁₆	A ₁₆	A ₁₆	A ₁₆	P5 ₀ /A ₁₆	P5 ₀	P5 ₀
54	A ₁₇	A ₁₇	A ₁₇	A ₁₇	P5 ₁ /A ₁₇	P5 ₁	P5 ₁
55	A ₁₈	A ₁₈	A ₁₈	A ₁₈	P5 ₂ /A ₁₈	P5 ₂	P5 ₂
56	A ₁₉	A ₁₉	A ₁₉	A ₁₉	P5 ₃ /A ₁₉	P5 ₃	P5 ₃
57	V _{SS}	V _{SS}	V _{SS}	V _{SS}	V _{SS}	V _{SS}	V _{SS}
58	P6 ₀ /WAIT	P6 ₀ /WAIT	P6 ₀ /WAIT	P6 ₀ /WAIT	P6 ₀ /WAIT	P6 ₀	P6 ₀
59	P6 ₁ /BREQ	P6 ₁ /BREQ	P6 ₁ /BREQ	P6 ₁ /BREQ	P6 ₁ /BREQ	P6 ₁	P6 ₁
60	P6 ₂ /BACK	P6 ₂ /BACK	P6 ₂ /BACK	P6 ₂ /BACK	P6 ₂ /BACK	P6 ₂	P6 ₂
61	φ	φ	φ	φ	P6 ₇ /φ	P6 ₇ /φ	P6 ₇ /φ
62	STBY	STBY	STBY	STBY	STBY	STBY	STBY
63	RES	RES	RES	RES	RES	RES	RES
64	NMI	NMI	NMI	NMI	NMI	NMI	NMI
65	V _{SS}	V _{SS}	V _{SS}	V _{SS}	V _{SS}	V _{SS}	V _{SS}
66	EXTAL	EXTAL	EXTAL	EXTAL	EXTAL	EXTAL	EXTAL
67	XTAL	XTAL	XTAL	XTAL	XTAL	XTAL	XTAL
68	V _{CC}	V _{CC}	V _{CC}	V _{CC}	V _{CC}	V _{CC}	V _{CC}
69	AS	AS	AS	AS	AS	P6 ₃	P6 ₃
70	RD	RD	RD	RD	RD	P6 ₄	P6 ₄
71	HWR	HWR	HWR	HWR	HWR	P6 ₅	P6 ₅
72	LWR	LWR	LWR	LWR	LWR	P6 ₆	P6 ₆
73	MD ₀	MD ₀	MD ₀	MD ₀	MD ₀	MD ₀	MD ₀
74	MD ₁	MD ₁	MD ₁	MD ₁	MD ₁	MD ₁	MD ₁
75	MD ₂	MD ₂	MD ₂	MD ₂	MD ₂	MD ₂	MD ₂
76	AV _{CC}	AV _{CC}	AV _{CC}	AV _{CC}	AV _{CC}	AV _{CC}	AV _{CC}
77	V _{REF}	V _{REF}	V _{REF}	V _{REF}	V _{REF}	V _{REF}	V _{REF}
78	P7 ₀ /AN ₀	P7 ₀ /AN ₀	P7 ₀ /AN ₀	P7 ₀ /AN ₀	P7 ₀ /AN ₀	P7 ₀ /AN ₀	P7 ₀ /AN ₀
79	P7 ₁ /AN ₁	P7 ₁ /AN ₁	P7 ₁ /AN ₁	P7 ₁ /AN ₁	P7 ₁ /AN ₁	P7 ₁ /AN ₁	P7 ₁ /AN ₁

Pin No.	Pin Name						
FP-100B TFP-100B	Mode 1	Mode 2	Mode 3	Mode 4	Mode 5	Mode 6	Mode 7
80	P7 ₂ /AN ₂	P7 ₂ /AN ₂	P7 ₂ /AN ₂	P7 ₂ /AN ₂	P7 ₂ /AN ₂	P7 ₂ /AN ₂	P7 ₂ /AN ₂
81	P7 ₃ /AN ₃	P7 ₃ /AN ₃	P7 ₃ /AN ₃	P7 ₃ /AN ₃	P7 ₃ /AN ₃	P7 ₃ /AN ₃	P7 ₃ /AN ₃
82	P7 ₄ /AN ₄	P7 ₄ /AN ₄	P7 ₄ /AN ₄	P7 ₄ /AN ₄	P7 ₄ /AN ₄	P7 ₄ /AN ₄	P7 ₄ /AN ₄
83	P7 ₅ /AN ₅	P7 ₅ /AN ₅	P7 ₅ /AN ₅	P7 ₅ /AN ₅	P7 ₅ /AN ₅	P7 ₅ /AN ₅	P7 ₅ /AN ₅
84	P7 ₆ /AN ₆ / DA ₀	P7 ₆ /AN ₆ / DA ₀	P7 ₆ /AN ₆ / DA ₀	P7 ₆ /AN ₆ / DA ₀	P7 ₆ /AN ₆ / DA ₀	P7 ₆ /AN ₆ / DA ₀	P7 ₆ /AN ₆ / DA ₀
85	P7 ₇ /AN ₇ / DA ₁	P7 ₇ /AN ₇ / DA ₁	P7 ₇ /AN ₇ / DA ₁	P7 ₇ /AN ₇ / DA ₁	P7 ₇ /AN ₇ / DA ₁	P7 ₇ /AN ₇ / DA ₁	P7 ₇ /AN ₇ / DA ₁
86	AV _{SS}	AV _{SS}	AV _{SS}	AV _{SS}	AV _{SS}	AV _{SS}	AV _{SS}
87	P8 ₀ /IRQ ₀ / RFSH	P8 ₀ /IRQ ₀ / RFSH	P8 ₀ /IRQ ₀ / RFSH	P8 ₀ /IRQ ₀ / RFSH	P8 ₀ /IRQ ₀ / RFSH	P8 ₀ /IRQ ₀	P8 ₀ /IRQ ₀
88	P8 ₁ /IRQ ₁ / CS ₃	P8 ₁ /IRQ ₁ / CS ₃	P8 ₁ /IRQ ₁ / CS ₃	P8 ₁ /IRQ ₁ / CS ₃	P8 ₁ /IRQ ₁ / CS ₃	P8 ₁ /IRQ ₁	P8 ₁ /IRQ ₁
89	P8 ₂ /IRQ ₂ / CS ₂	P8 ₂ /IRQ ₂ / CS ₂	P8 ₂ /IRQ ₂ / CS ₂	P8 ₂ /IRQ ₂ / CS ₂	P8 ₂ /IRQ ₂ / CS ₂	P8 ₂ /IRQ ₂	P8 ₂ /IRQ ₂
90	P8 ₃ /IRQ ₃ / CS ₁ / ADTRG	P8 ₃ /IRQ ₃ / CS ₁ / ADTRG	P8 ₃ /IRQ ₃ / CS ₁ / ADTRG	P8 ₃ /IRQ ₃ / CS ₁ / ADTRG	P8 ₃ /IRQ ₃ / CS ₁ / ADTRG	P8 ₃ /IRQ ₃ / ADTRG	P8 ₃ /IRQ ₃ / ADTRG
91	P8 ₄ /CS ₀	P8 ₄ /CS ₀	P8 ₄ /CS ₀	P8 ₄ /CS ₀	P8 ₄ /CS ₀	P8 ₄	P8 ₄
92	V _{SS}	V _{SS}	V _{SS}	V _{SS}	V _{SS}	V _{SS}	V _{SS}
93	PA ₀ /TP ₀ / TCLKA/ TEND ₀	PA ₀ /TP ₀ / TCLKA/ TEND ₀	PA ₀ /TP ₀ / TCLKA/ TEND ₀	PA ₀ /TP ₀ / TCLKA/ TEND ₀	PA ₀ /TP ₀ / TCLKA/ TEND ₀	PA ₀ /TP ₀ / TCLKA/ TEND ₀	PA ₀ /TP ₀ / TCLKA/ TEND ₀
94	PA ₁ /TP ₁ / TCLKB/ TEND ₁	PA ₁ /TP ₁ / TCLKB/ TEND ₁	PA ₁ /TP ₁ / TCLKB/ TEND ₁	PA ₁ /TP ₁ / TCLKB/ TEND ₁	PA ₁ /TP ₁ / TCLKB/ TEND ₁	PA ₁ /TP ₁ / TCLKB/ TEND ₁	PA ₁ /TP ₁ / TCLKB/ TEND ₁
95	PA ₂ /TP ₂ / TIOCA ₀ / TCLKC	PA ₂ /TP ₂ / TIOCA ₀ / TCLKC	PA ₂ /TP ₂ / TIOCA ₀ / TCLKC	PA ₂ /TP ₂ / TIOCA ₀ / TCLKC	PA ₂ /TP ₂ / TIOCA ₀ / TCLKC	PA ₂ /TP ₂ / TIOCA ₀ / TCLKC	PA ₂ /TP ₂ / TIOCA ₀ / TCLKC
96	PA ₃ /TP ₃ / TIOCB ₀ / TCLKD	PA ₃ /TP ₃ / TIOCB ₀ / TCLKD	PA ₃ /TP ₃ / TIOCB ₀ / TCLKD	PA ₃ /TP ₃ / TIOCB ₀ / TCLKD	PA ₃ /TP ₃ / TIOCB ₀ / TCLKD	PA ₃ /TP ₃ / TIOCB ₀ / TCLKD	PA ₃ /TP ₃ / TIOCB ₀ / TCLKD
97	PA ₄ /TP ₄ / TIOCA ₁	PA ₄ /TP ₄ / TIOCA ₁	PA ₄ /TP ₄ / TIOCA ₁ / A ₂₃	PA ₄ /TP ₄ / TIOCA ₁ / A ₂₃	PA ₄ /TP ₄ / TIOCA ₁ / A ₂₃	PA ₄ /TP ₄ / TIOCA ₁	PA ₄ /TP ₄ / TIOCA ₁

Pin No.	Pin Name						
FP-100B TFP-100B	Mode 1	Mode 2	Mode 3	Mode 4	Mode 5	Mode 6	Mode 7
98	PA ₅ /TP ₅ / TIOCB ₁	PA ₅ /TP ₅ / TIOCB ₁	PA ₅ /TP ₅ / TIOCB ₁ / A ₂₂	PA ₅ /TP ₅ / TIOCB ₁ / A ₂₂	PA ₅ /TP ₅ / TIOCB ₁ / A ₂₂	PA ₅ /TP ₅ / TIOCB ₁	PA ₅ /TP ₅ / TIOCB ₁
99	PA ₆ /TP ₆ / TIOCA ₂	PA ₆ /TP ₆ / TIOCA ₂	PA ₆ /TP ₆ / TIOCA ₂ / A ₂₁	PA ₆ /TP ₆ / TIOCA ₂ / A ₂₁	PA ₆ /TP ₆ / TIOCA ₂ / A ₂₁	PA ₆ /TP ₆ / TIOCA ₂	PA ₆ /TP ₆ / TIOCA ₂
100	PA ₇ /TP ₇ / TIOCB ₂	PA ₇ /TP ₇ / TIOCB ₂	A ₂₀	A ₂₀	PA ₇ /TP ₇ / TIOCB ₂ / A ₂₀	PA ₇ /TP ₇ / TIOCB ₂	PA ₇ /TP ₇ / TIOCB ₂

- Notes:
1. Functions as V_{CL} pin.
 2. In modes 1, 3, 5 the P₄₀ to P₄₇ functions of pins P₄₀/D₀ to P₄₇/D₇ are selected after a reset, but they can be changed by software.
 3. In modes 2 and 4 the D₀ to D₇ functions of pins P₄₀/D₀ to P₄₇/D₇ are selected after a reset, but they can be changed by software.

Section 2 CPU

2.1 Overview

The H8/300H CPU is a high-speed central processing unit with an internal 32-bit architecture that is upward-compatible with the H8/300 CPU. The H8/300H CPU has sixteen 16-bit general registers, can address a 16-Mbyte linear address space, and is ideal for realtime control.

2.1.1 Features

The H8/300H CPU has the following features.

- Upward compatibility with H8/300 CPU
Can execute H8/300 Series object programs
- General-register architecture
Sixteen 16-bit general registers (also usable as sixteen 8-bit registers or eight 32-bit registers)
- Sixty-two basic instructions
 - 8/16/32-bit arithmetic and logic instructions
 - Multiply and divide instructions
 - Powerful bit-manipulation instructions
- Eight addressing modes
 - Register direct [Rn]
 - Register indirect [@ERn]
 - Register indirect with displacement [@(d:16, ERn) or @(d:24, ERn)]
 - Register indirect with post-increment or pre-decrement [@ERn+ or @-ERn]
 - Absolute address [@aa:8, @aa:16, or @aa:24]
 - Immediate [#xx:8, #xx:16, or #xx:32]
 - Program-counter relative [@(d:8, PC) or @(d:16, PC)]
 - Memory indirect [@@aa:8]
- 16-Mbyte linear address space

- High-speed operation
 - All frequently-used instructions execute in two to four states
 - Maximum clock frequency: 25 MHz
 - 8/16/32-bit register-register add/subtract: 80 ns
 - 8×8 -bit register-register multiply: 560 ns
 - $16 \div 8$ -bit register-register divide: 560 ns
 - 16×16 -bit register-register multiply: 880 ns
 - $32 \div 16$ -bit register-register divide: 880 ns
- Two CPU operating modes
 - Normal mode
 - Advanced mode
- Low-power mode
 - Transition to power-down state by SLEEP instruction

2.1.2 Differences from H8/300 CPU

In comparison to the H8/300 CPU, the H8/300H has the following enhancements.

- More general registers
 - Eight 16-bit registers have been added.
- Expanded address space
 - Advanced mode supports a maximum 16-Mbyte address space.
 - Normal mode supports the same 64-kbyte address space as the H8/300 CPU.
- Enhanced addressing
 - The addressing modes have been enhanced to make effective use of the 16-Mbyte address space.
- Enhanced instructions
 - Data transfer, arithmetic, and logic instructions can operate on 32-bit data.
 - Signed multiply/divide instructions and other instructions have been added.

2.2 CPU Operating Modes

The H8/300H CPU has two operating modes: normal and advanced. Normal mode supports a maximum 64-kbyte address space. Advanced mode supports up to 16 Mbytes.

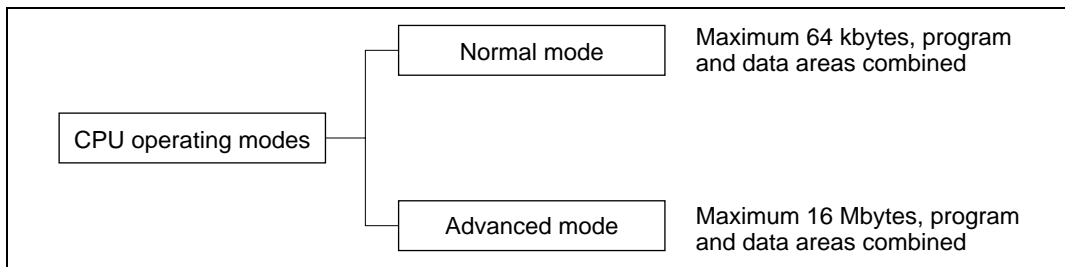

Figure 2.1 CPU Operating Modes

2.3 Address Space

Figure 2.2 shows a simple memory map for the H8/3068F. The H8/300H CPU can address a linear address space with a maximum size of 64 kbytes in normal mode, and 16 Mbytes in advanced mode. For further details see section 3.6, Memory Map in Each Operating Mode.

The 1-Mbyte operating modes use 20-bit addressing. The upper 4 bits of effective addresses are ignored.

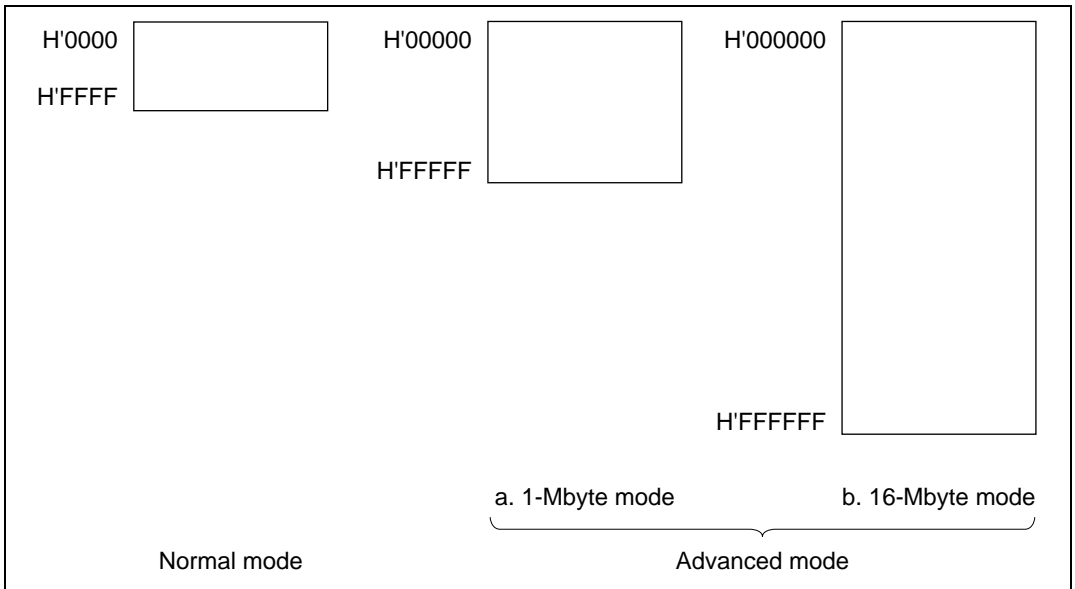

Figure 2.2 Memory Map

2.4 Register Configuration

2.4.1 Overview

The H8/300H CPU has the internal registers shown in figure 2.3. There are two types of registers: general registers and control registers.

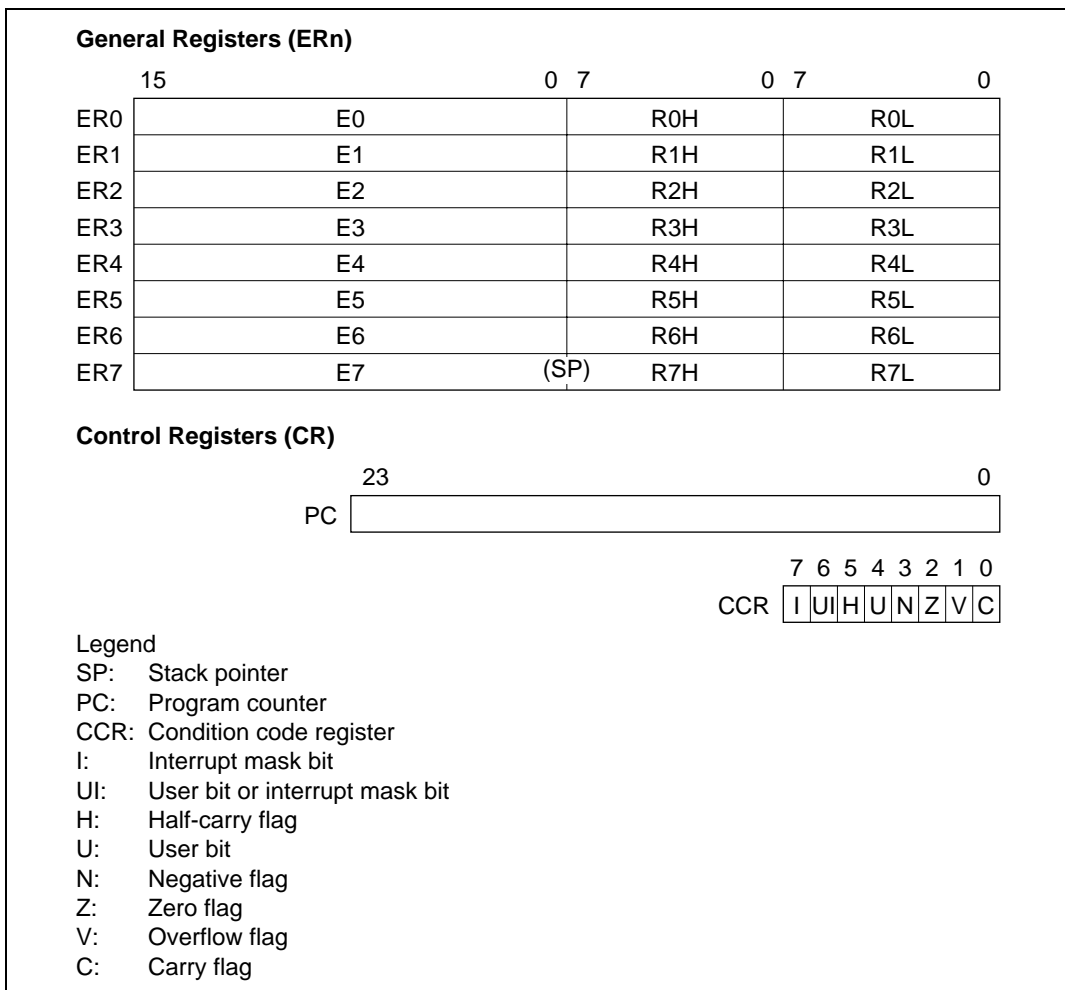

Figure 2.3 CPU Registers

2.4.2 General Registers

The H8/300H CPU has eight 32-bit general registers. These general registers are all functionally alike and can be used without distinction between data registers and address registers. When a general register is used as a data register, it can be accessed as a 32-bit, 16-bit, or 8-bit register. When the general registers are used as 32-bit registers or as address registers, they are designated by the letters ER (ER0 to ER7).

The ER registers divide into 16-bit general registers designated by the letters E (E0 to E7) and R (R0 to R7). These registers are functionally equivalent, providing a maximum sixteen 16-bit registers. The E registers (E0 to E7) are also referred to as extended registers.

The R registers divide into 8-bit general registers designated by the letters RH (R0H to R7H) and RL (R0L to R7L). These registers are functionally equivalent, providing a maximum sixteen 8-bit registers.

Figure 2.4 illustrates the usage of the general registers. The usage of each register can be selected independently.

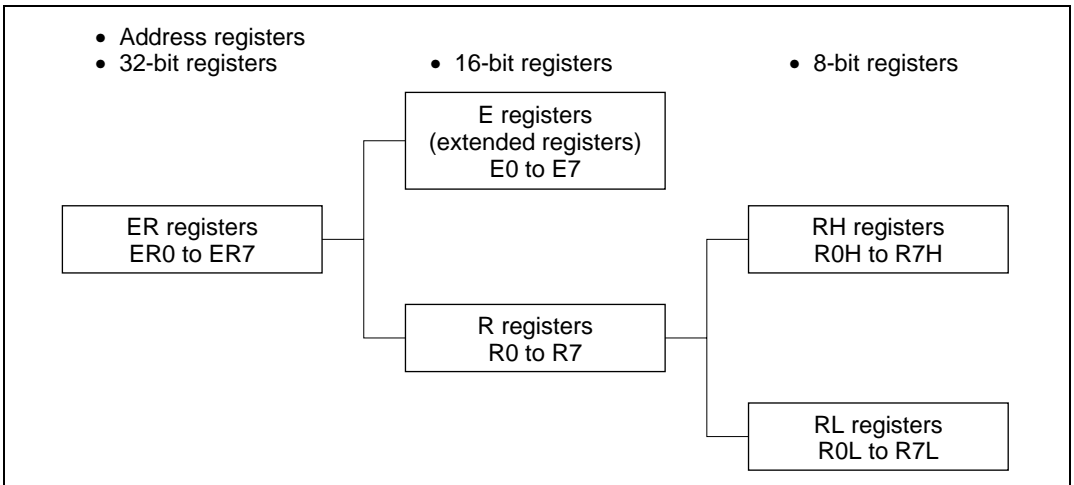

Figure 2.4 Usage of General Registers

General register ER7 has the function of stack pointer (SP) in addition to its general-register function, and is used implicitly in exception handling and subroutine calls. Figure 2.5 shows the stack.

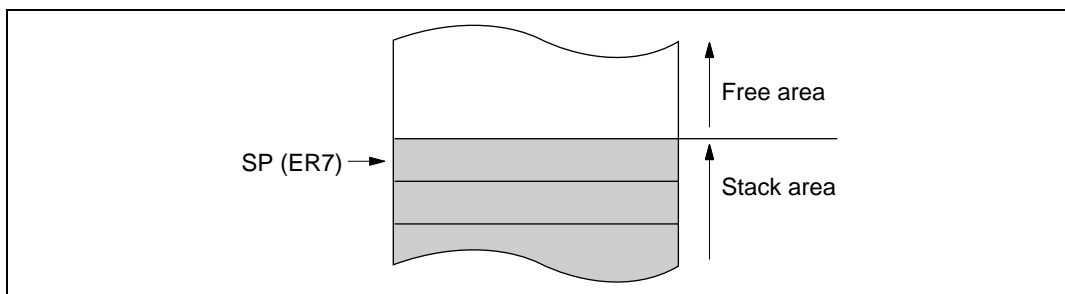

Figure 2.5 Stack

2.4.3 Control Registers

The control registers are the 24-bit program counter (PC) and the 8-bit condition code register (CCR).

Program Counter (PC): This 24-bit counter indicates the address of the next instruction the CPU will execute. The length of all CPU instructions is 2 bytes (one word), so the least significant PC bit is ignored. When an instruction is fetched, the least significant PC bit is regarded as 0.

Condition Code Register (CCR): This 8-bit register contains internal CPU status information, including the interrupt mask bit (I) and half-carry (H), negative (N), zero (Z), overflow (V), and carry (C) flags.

Bit 7—Interrupt Mask Bit (I): Masks interrupts other than NMI when set to 1. NMI is accepted regardless of the I bit setting. The I bit is set to 1 at the start of an exception-handling sequence.

Bit 6—User Bit or Interrupt Mask Bit (UI): Can be written and read by software using the LDC, STC, ANDC, ORC, and XORC instructions. This bit can also be used as an interrupt mask bit. For details see section 5, Interrupt Controller.

Bit 5—Half-Carry Flag (H): When the ADD.B, ADDX.B, SUB.B, SUBX.B, CMP.B, or NEG.B instruction is executed, this flag is set to 1 if there is a carry or borrow at bit 3, and cleared to 0 otherwise. When the ADD.W, SUB.W, CMP.W, or NEG.W instruction is executed, the H flag is set to 1 if there is a carry or borrow at bit 11, and cleared to 0 otherwise. When the ADD.L, SUB.L, CMP.L, or NEG.L instruction is executed, the H flag is set to 1 if there is a carry or borrow at bit 27, and cleared to 0 otherwise.

Bit 4—User Bit (U): Can be written and read by software using the LDC, STC, ANDC, ORC, and XORC instructions.

Bit 3—Negative Flag (N): Stores the value of the most significant bit of data, regarded as the sign bit.

Bit 2—Zero Flag (Z): Set to 1 to indicate zero data, and cleared to 0 to indicate non-zero data.

Bit 1—Overflow Flag (V): Set to 1 when an arithmetic overflow occurs, and cleared to 0 at other times.

Bit 0—Carry Flag (C): Set to 1 when a carry is generated by execution of an operation, and cleared to 0 otherwise. Used by:

- Add instructions, to indicate a carry
- Subtract instructions, to indicate a borrow
- Shift and rotate instructions

The carry flag is also used as a bit accumulator by bit manipulation instructions.

Some instructions leave flag bits unchanged. Operations can be performed on CCR by the LDC, STC, ANDC, ORC, and XORC instructions. The N, Z, V, and C flags are used by conditional branch (Bcc) instructions.

For the action of each instruction on the flag bits, see appendix A.1, Instruction List. For the I and UI bits, see section 5, Interrupt Controller.

2.4.4 Initial CPU Register Values

In reset exception handling, PC is initialized to a value loaded from the vector table, and the I bit in CCR is set to 1. The other CCR bits and the general registers are not initialized. In particular, the initial value of the stack pointer (ER7) is also undefined. The stack pointer (ER7) must therefore be initialized by an MOV.L instruction executed immediately after a reset.

2.5 Data Formats

The H8/300H CPU can process 1-bit, 4-bit (BCD), 8-bit (byte), 16-bit (word), and 32-bit (longword) data. Bit-manipulation instructions operate on 1-bit data by accessing bit n ($n = 0, 1, 2, \dots, 7$) of byte operand data. The DAA and DAS decimal-adjust instructions treat byte data as two digits of 4-bit BCD data.

2.5.1 General Register Data Formats

Figures 2.6 and 2.7 show the data formats in general registers.

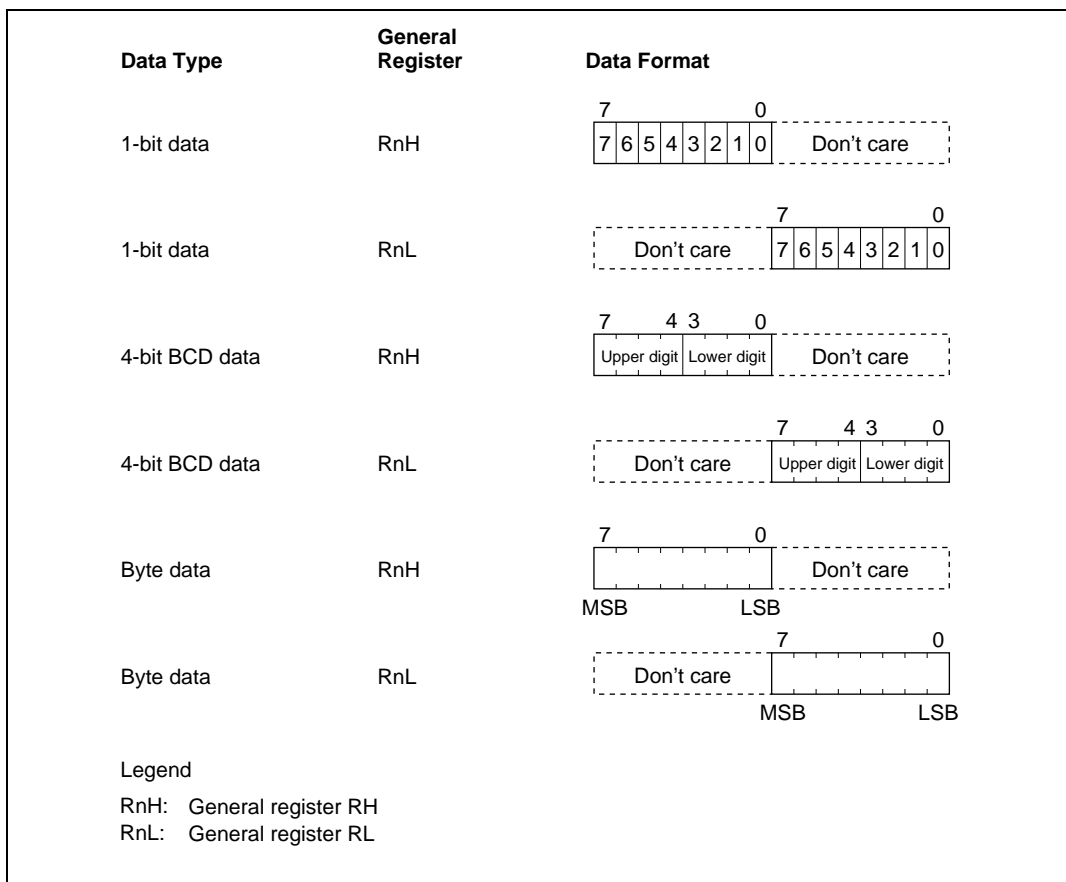
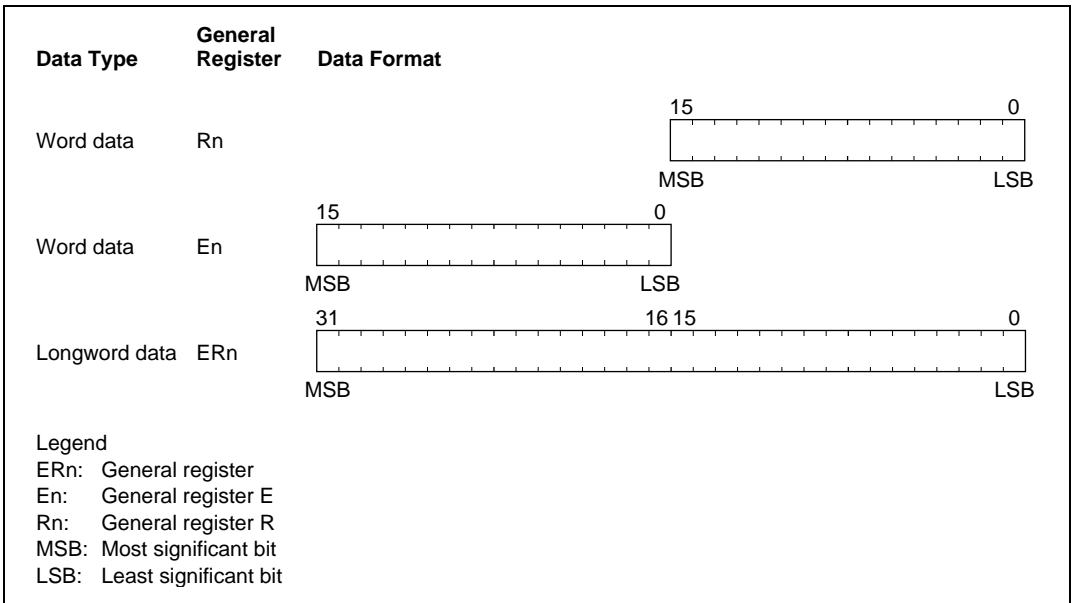

Figure 2.6 General Register Data Formats

**Figure 2.7 General Register Data Formats**

2.5.2 Memory Data Formats

Figure 2.8 shows the data formats on memory. The H8/300H CPU can access word data and longword data on memory, but word or longword data must begin at an even address. If an attempt is made to access word or longword data at an odd address, no address error occurs but the least significant bit of the address is regarded as 0, so the access starts at the preceding address. This also applies to instruction fetches.

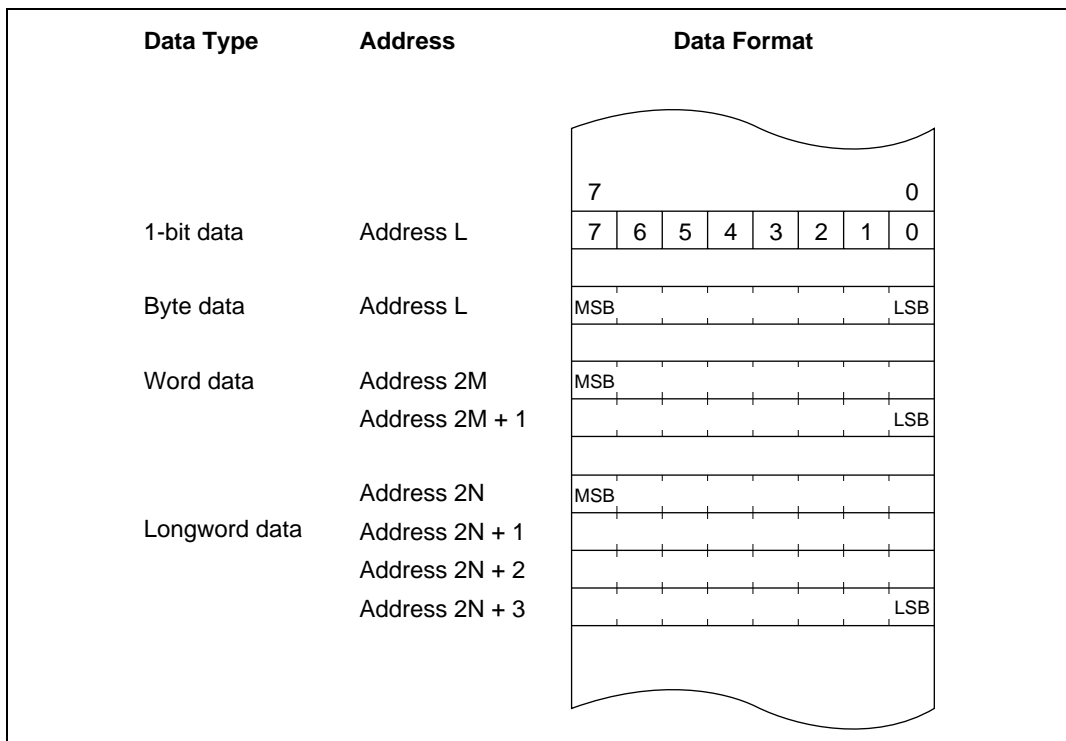

Figure 2.8 Memory Data Formats

When ER7 (SP) is used as an address register to access the stack, the operand size should be word size or longword size.

2.6 Instruction Set

2.6.1 Instruction Set Overview

The H8/300H CPU has 62 types of instructions, which are classified in table 2.1.

Table 2.1 Instruction Classification

Function	Instruction	Types
Data transfer	MOV, PUSH* ¹ , POP* ¹ , MOVTPE* ² , MOVFPE* ²	3
Arithmetic operations	ADD, SUB, ADDX, SUBX, INC, DEC, ADDS, SUBS, DAA, DAS, MULXU, MULXS, DIVXU, DIVXS, CMP, NEG, EXTS, EXTU	18
Logic operations	AND, OR, XOR, NOT	4
Shift operations	SHAL, SHAR, SHLL, SHLR, ROTL, ROTR, ROTXL, ROTXR	8
Bit manipulation	BSET, BCLR, BNOT, BTST, BAND, BIAN, BOR, BIOR, BXOR, BIXOR, BLD, BILD, BST, BIST	14
Branch	Bcc* ³ , JMP, BSR, JSR, RTS	5
System control	TRAPA, RTE, SLEEP, LDC, STC, ANDC, ORC, XORC, NOP	9
Block data transfer	EPMOV	1

Total 62 types

- Notes:
1. POP.W Rn is identical to MOV.W @SP+, Rn.
 PUSH.W Rn is identical to MOV.W Rn, @-SP.
 POP.L ERn is identical to MOV.L @SP+, Rn.
 PUSH.L ERn is identical to MOV.L Rn, @-SP.
 2. Not available in the H8/3068F.
 3. Bcc is a generic branching instruction.

2.6.2 Instructions and Addressing Modes

Table 2.2 indicates the instructions available in the H8/300H CPU.

Table 2.2 Instructions and Addressing Modes

Function	Instruction	#xx	Rn	Addressing Modes										
				@ERn	@(d:16, ERn)	@(d:24, ERn)	@ERn+/@-ERn	@aa:8	@aa:16	@aa:24	@(d:8, PC)	@(d:16, PC)	@@aa:8	—
Data transfer	MOV	BWL	BWL	BWL	BWL	BWL	BWL	B	BWL	BWL	—	—	—	—
	POP, PUSH	—	—	—	—	—	—	—	—	—	—	—	—	WL
	MOVFP, MOVTP	—	—	—	—	—	—	—	—	—	—	—	—	—
Arithmetic operations	ADD, CMP	BWL	BWL	—	—	—	—	—	—	—	—	—	—	—
	SUB	WL	BWL	—	—	—	—	—	—	—	—	—	—	—
	ADDX, SUBX	B	B	—	—	—	—	—	—	—	—	—	—	—
	ADDS, SUBS	—	L	—	—	—	—	—	—	—	—	—	—	—
	INC, DEC	—	BWL	—	—	—	—	—	—	—	—	—	—	—
	DAA, DAS	—	B	—	—	—	—	—	—	—	—	—	—	—
	MULXU, MULXS, DIVXU, DIVXS	—	BW	—	—	—	—	—	—	—	—	—	—	—
	NEG	—	BWL	—	—	—	—	—	—	—	—	—	—	—
	EXTU, EXTS	—	WL	—	—	—	—	—	—	—	—	—	—	—
Logic operations	AND, OR, XOR	—	BWL	—	—	—	—	—	—	—	—	—	—	—
	NOT	—	BWL	—	—	—	—	—	—	—	—	—	—	—
Shift instructions	—	BWL	—	—	—	—	—	—	—	—	—	—	—	
Bit manipulation	—	B	B	—	—	—	B	—	—	—	—	—	—	
Branch	Bcc, BSR	—	—	—	—	—	—	—	—	—	—	—	—	—
	JMP, JSR	—	—	○	—	—	—	—	—	—	○	○	—	—
	RTS	—	—	—	—	—	—	—	—	○	—	—	○	—
System control	TRAPA	—	—	—	—	—	—	—	—	—	—	—	—	○
	RTE	—	—	—	—	—	—	—	—	—	—	—	—	○
	SLEEP	—	—	—	—	—	—	—	—	—	—	—	—	○
	LDC	B	B	W	W	W	W	—	W	W	—	—	—	○
	STC	—	B	W	W	W	W	—	W	W	—	—	—	—
	ANDC, ORC, XORC	B	—	—	—	—	—	—	—	—	—	—	—	—
	NOP	—	—	—	—	—	—	—	—	—	—	—	—	○
Block data transfer	—	—	—	—	—	—	—	—	—	—	—	—	—	BW

2.6.3 Tables of Instructions Classified by Function

Tables 2.3 to 2.10 summarize the instructions in each functional category. The operation notation used in these tables is defined next.

Operation Notation

Rd	General register (destination)*
Rs	General register (source)*
Rn	General register*
ERn	General register (32-bit register or address register)
(EAd)	Destination operand
(EAs)	Source operand
CCR	Condition code register
N	N (negative) flag of CCR
Z	Z (zero) flag of CCR
V	V (overflow) flag of CCR
C	C (carry) flag of CCR
PC	Program counter
SP	Stack pointer
#IMM	Immediate data
disp	Displacement
+	Addition
−	Subtraction
×	Multiplication
÷	Division
^	AND logical
∨	OR logical
⊕	Exclusive OR logical
→	Move
¬	NOT (logical complement)
:3/:8/:16/:24	3-, 8-, 16-, or 24-bit length

Note: *General registers include 8-bit registers (R0H to R7H, R0L to R7L), 16-bit registers (R0 to R7, E0 to E7), and 32-bit data or address registers (ER0 to ER7).

Table 2.3 Data Transfer Instructions

Instruction	Size*	Function
MOV	B/W/L	(EAs) → Rd, Rs → (EAd) Moves data between two general registers or between a general register and memory, or moves immediate data to a general register.
MOVFPE	B	(EAs) → Rd Cannot be used in this LSI.
MOVTPE	B	Rs → (EAs) Cannot be used in this LSI.
POP	W/L	@SP+ → Rn Pops a general register from the stack. POP.W Rn is identical to MOV.W @SP+, Rn. Similarly, POP.L ERn is identical to MOV.L @SP+, ERn.
PUSH	W/L	Rn → @-SP Pushes a general register onto the stack. PUSH.W Rn is identical to MOV.W Rn, @-SP. Similarly, PUSH.L ERn is identical to MOV.L ERn, @-SP.

Note: *Size refers to the operand size.

B: Byte

W: Word

L: Longword

Table 2.4 Arithmetic Operation Instructions

Instruction	Size*	Function
ADD,SUB	B/W/L	$Rd \pm Rs \rightarrow Rd$, $Rd \pm \#IMM \rightarrow Rd$ Performs addition or subtraction on data in two general registers, or on immediate data and data in a general register. (Immediate byte data cannot be subtracted from data in a general register. Use the SUBX or ADD instruction.)
ADDX, SUBX	B	$Rd \pm Rs \pm C \rightarrow Rd$, $Rd \pm \#IMM \pm C \rightarrow Rd$ Performs addition or subtraction with carry or borrow on data in two general registers, or on immediate data and data in a general register.
INC, DEC	B/W/L	$Rd \pm 1 \rightarrow Rd$, $Rd \pm 2 \rightarrow Rd$ Increments or decrements a general register by 1 or 2. (Byte operands can be incremented or decremented by 1 only.)
ADDS, SUBS	L	$Rd \pm 1 \rightarrow Rd$, $Rd \pm 2 \rightarrow Rd$, $Rd \pm 4 \rightarrow Rd$ Adds or subtracts the value 1, 2, or 4 to or from data in a 32-bit register.
DAA, DAS	B	Rd decimal adjust $\rightarrow Rd$ Decimal-adjusts an addition or subtraction result in a general register by referring to CCR to produce 4-bit BCD data.
MULXU	B/W	$Rd \times Rs \rightarrow Rd$ Performs unsigned multiplication on data in two general registers: either 8 bits \times 8 bits \rightarrow 16 bits or 16 bits \times 16 bits \rightarrow 32 bits.
MULXS	B/W	$Rd \times Rs \rightarrow Rd$ Performs signed multiplication on data in two general registers: either 8 bits \times 8 bits \rightarrow 16 bits or 16 bits \times 16 bits \rightarrow 32 bits.
DIVXU	B/W	$Rd \div Rs \rightarrow Rd$ Performs unsigned division on data in two general registers: either 16 bits \div 8 bits \rightarrow 8-bit quotient and 8-bit remainder or 32 bits \div 16 bits \rightarrow 16-bit quotient and 16-bit remainder
DIVXS	B/W	$Rd \div Rs \rightarrow Rd$ Performs signed division on data in two general registers: either 16 bits \div 8 bits \rightarrow 8-bit quotient and 8-bit remainder, or 32 bits \div 16 bits \rightarrow 16-bit quotient and 16-bit remainder
CMP	B/W/L	$Rd - Rs$, $Rd - \#IMM$ Compares data in a general register with data in another general register or with immediate data, and sets CCR according to the result.
NEG	B/W/L	$0 - Rd \rightarrow Rd$ Takes the two's complement (arithmetic complement) of data in a general register.

Instruction	Size*	Function
EXTS	W/L	Rd (sign extension) → Rd Extends byte data in the lower 8 bits of a 16-bit register to word data, or extends word data in the lower 16 bits of a 32-bit register to longword data, by extending the sign bit.
EXTU	W/L	Rd (zero extension) → Rd Extends byte data in the lower 8 bits of a 16-bit register to word data, or extends word data in the lower 16 bits of a 32-bit register to longword data, by padding with zeros.

Note: * Size refers to the operand size.

B: Byte

W: Word

L: Longword

Table 2.5 Logic Operation Instructions

Instruction	Size*	Function
AND	B/W/L	$Rd \wedge Rs \rightarrow Rd$, $Rd \wedge \#IMM \rightarrow Rd$ Performs a logical AND operation on a general register and another general register or immediate data.
OR	B/W/L	$Rd \vee Rs \rightarrow Rd$, $Rd \vee \#IMM \rightarrow Rd$ Performs a logical OR operation on a general register and another general register or immediate data.
XOR	B/W/L	$Rd \oplus Rs \rightarrow Rd$, $Rd \oplus \#IMM \rightarrow Rd$ Performs a logical exclusive OR operation on a general register and another general register or immediate data.
NOT	B/W/L	$\neg Rd \rightarrow Rd$ Takes the one's complement (logical complement) of general register contents.

Note: * Size refers to the operand size.

B: Byte

W: Word

L: Longword

Table 2.6 Shift Instructions

Instruction	Size*	Function
SHAL, SHAR	B/W/L	Rd (shift) → Rd Performs an arithmetic shift on general register contents.
SHLL, SHLR	B/W/L	Rd (shift) → Rd Performs a logical shift on general register contents.
ROTL, ROTR	B/W/L	Rd (rotate) → Rd Rotates general register contents.
ROTXL, ROTXR	B/W/L	Rd (rotate) → Rd Rotates general register contents, including the carry bit.

Note: * Size refers to the operand size.

B: Byte

W: Word

L: Longword

Table 2.7 Bit Manipulation Instructions

Instruction	Size*	Function
BSET	B	$1 \rightarrow \langle \text{bit-No.} \rangle \text{ of } \langle \text{EAd} \rangle$ Sets a specified bit in a general register or memory operand to 1. The bit number is specified by 3-bit immediate data or the lower 3 bits of a general register.
BCLR	B	$0 \rightarrow \langle \text{bit-No.} \rangle \text{ of } \langle \text{EAd} \rangle$ Clears a specified bit in a general register or memory operand to 0. The bit number is specified by 3-bit immediate data or the lower 3 bits of a general register.
BNOT	B	$\neg \langle \text{bit-No.} \rangle \text{ of } \langle \text{EAd} \rangle \rightarrow \langle \text{bit-No.} \rangle \text{ of } \langle \text{EAd} \rangle$ Inverts a specified bit in a general register or memory operand. The bit number is specified by 3-bit immediate data or the lower 3 bits of a general register.
BTST	B	$\neg \langle \text{bit-No.} \rangle \text{ of } \langle \text{EAd} \rangle \rightarrow Z$ Tests a specified bit in a general register or memory operand and sets or clears the Z flag accordingly. The bit number is specified by 3-bit immediate data or the lower 3 bits of a general register.
BAND	B	$C \wedge \langle \text{bit-No.} \rangle \text{ of } \langle \text{EAd} \rangle \rightarrow C$ ANDs the carry flag with a specified bit in a general register or memory operand and stores the result in the carry flag.
BIAND	B	$C \wedge [\neg \langle \text{bit-No.} \rangle \text{ of } \langle \text{EAd} \rangle] \rightarrow C$ ANDs the carry flag with the inverse of a specified bit in a general register or memory operand and stores the result in the carry flag. The bit number is specified by 3-bit immediate data.
BOR	B	$C \vee \langle \text{bit-No.} \rangle \text{ of } \langle \text{EAd} \rangle \rightarrow C$ ORs the carry flag with a specified bit in a general register or memory operand and stores the result in the carry flag.
BIOR	B	$C \vee [\neg \langle \text{bit-No.} \rangle \text{ of } \langle \text{EAd} \rangle] \rightarrow C$ ORs the carry flag with the inverse of a specified bit in a general register or memory operand and stores the result in the carry flag. The bit number is specified by 3-bit immediate data.
BXOR	B	$C \oplus \langle \text{bit-No.} \rangle \text{ of } \langle \text{EAd} \rangle \rightarrow C$ Exclusive-ORs the carry flag with a specified bit in a general register or memory operand and stores the result in the carry flag.

Instruction	Size*	Function
BIXOR	B	$C \oplus [\neg (\text{<bit-No.> of <EAd>})] \rightarrow C$ Exclusive-ORs the carry flag with the inverse of a specified bit in a general register or memory operand and stores the result in the carry flag. The bit number is specified by 3-bit immediate data.
BLD	B	$(\text{<bit-No.> of <EAd>}) \rightarrow C$ Transfers a specified bit in a general register or memory operand to the carry flag.
BILD	B	$\neg (\text{<bit-No.> of <EAd>}) \rightarrow C$ Transfers the inverse of a specified bit in a general register or memory operand to the carry flag. The bit number is specified by 3-bit immediate data.
BST	B	$C \rightarrow (\text{<bit-No.> of <EAd>})$ Transfers the carry flag value to a specified bit in a general register or memory operand.
BIST	B	$C \rightarrow \neg (\text{<bit-No.> of <EAd>})$ Transfers the inverse of the carry flag value to a specified bit in a general register or memory operand. The bit number is specified by 3-bit immediate data.

Note: * Size refers to the operand size.

B: Byte

Table 2.8 Branching Instructions

Instruction	Size	Function																																																			
Bcc	—	Branches to a specified address if address specified condition is met. The branching conditions are listed below.																																																			
		<table border="1"> <thead> <tr> <th>Mnemonic</th> <th>Description</th> <th>Condition</th> </tr> </thead> <tbody> <tr> <td>BRA (BT)</td> <td>Always (true)</td> <td>Always</td> </tr> <tr> <td>BRN (BF)</td> <td>Never (false)</td> <td>Never</td> </tr> <tr> <td>BHI</td> <td>High</td> <td>$C \vee Z = 0$</td> </tr> <tr> <td>BLS</td> <td>Low or same</td> <td>$C \vee Z = 1$</td> </tr> <tr> <td>Bcc (BHS)</td> <td>Carry clear (high or same)</td> <td>$C = 0$</td> </tr> <tr> <td>BCS (BLO)</td> <td>Carry set (low)</td> <td>$C = 1$</td> </tr> <tr> <td>BNE</td> <td>Not equal</td> <td>$Z = 0$</td> </tr> <tr> <td>BEQ</td> <td>Equal</td> <td>$Z = 1$</td> </tr> <tr> <td>BVC</td> <td>Overflow clear</td> <td>$V = 0$</td> </tr> <tr> <td>BVS</td> <td>Overflow set</td> <td>$V = 1$</td> </tr> <tr> <td>BPL</td> <td>Plus</td> <td>$N = 0$</td> </tr> <tr> <td>BMI</td> <td>Minus</td> <td>$N = 1$</td> </tr> <tr> <td>BGE</td> <td>Greater or equal</td> <td>$N \oplus V = 0$</td> </tr> <tr> <td>BLT</td> <td>Less than</td> <td>$N \oplus V = 1$</td> </tr> <tr> <td>BGT</td> <td>Greater than</td> <td>$Z \vee (N \oplus V) = 0$</td> </tr> <tr> <td>BLE</td> <td>Less or equal</td> <td>$Z \vee (N \oplus V) = 1$</td> </tr> </tbody> </table>	Mnemonic	Description	Condition	BRA (BT)	Always (true)	Always	BRN (BF)	Never (false)	Never	BHI	High	$C \vee Z = 0$	BLS	Low or same	$C \vee Z = 1$	Bcc (BHS)	Carry clear (high or same)	$C = 0$	BCS (BLO)	Carry set (low)	$C = 1$	BNE	Not equal	$Z = 0$	BEQ	Equal	$Z = 1$	BVC	Overflow clear	$V = 0$	BVS	Overflow set	$V = 1$	BPL	Plus	$N = 0$	BMI	Minus	$N = 1$	BGE	Greater or equal	$N \oplus V = 0$	BLT	Less than	$N \oplus V = 1$	BGT	Greater than	$Z \vee (N \oplus V) = 0$	BLE	Less or equal	$Z \vee (N \oplus V) = 1$
Mnemonic	Description	Condition																																																			
BRA (BT)	Always (true)	Always																																																			
BRN (BF)	Never (false)	Never																																																			
BHI	High	$C \vee Z = 0$																																																			
BLS	Low or same	$C \vee Z = 1$																																																			
Bcc (BHS)	Carry clear (high or same)	$C = 0$																																																			
BCS (BLO)	Carry set (low)	$C = 1$																																																			
BNE	Not equal	$Z = 0$																																																			
BEQ	Equal	$Z = 1$																																																			
BVC	Overflow clear	$V = 0$																																																			
BVS	Overflow set	$V = 1$																																																			
BPL	Plus	$N = 0$																																																			
BMI	Minus	$N = 1$																																																			
BGE	Greater or equal	$N \oplus V = 0$																																																			
BLT	Less than	$N \oplus V = 1$																																																			
BGT	Greater than	$Z \vee (N \oplus V) = 0$																																																			
BLE	Less or equal	$Z \vee (N \oplus V) = 1$																																																			
JMP	—	Branches unconditionally to a specified address																																																			
BSR	—	Branches to a subroutine at a specified address																																																			
JSR	—	Branches to a subroutine at a specified address																																																			
RTS	—	Returns from a subroutine																																																			

Table 2.9 System Control Instructions

Instruction	Size*	Function
TRAPA	—	Starts trap-instruction exception handling
RTE	—	Returns from an exception-handling routine
SLEEP	—	Causes a transition to the power-down state
LDC	B/W	(EAs) → CCR Moves the source operand contents to the condition code register. The condition code register size is one byte, but in transfer from memory, data is read by word access.
STC	B/W	CCR → (EAd) Transfers the CCR contents to a destination location. The condition code register size is one byte, but in transfer to memory, data is written by word access.
ANDC	B	CCR ∧ #IMM → CCR Logically ANDs the condition code register with immediate data.
ORC	B	CCR ∨ #IMM → CCR Logically ORs the condition code register with immediate data.
XORC	B	CCR ⊕ #IMM → CCR Logically exclusive-ORs the condition code register with immediate data.
NOP	—	PC + 2 → PC Only increments the program counter.

Note: * Size refers to the operand size.

B: Byte

W: Word

Table 2.10 Block Transfer Instruction

Instruction	Size	Function
EEMOV.B	—	if R4L ≠ 0 then repeat @ER5+ → @ER6+, R4L – 1 → R4L until R4L = 0 else next;
EEMOV.W	—	if R4 ≠ 0 then repeat @ER5+ → @ER6+, R4 – 1 → R4 until R4 = 0 else next; Block transfer instruction. This instruction transfers the number of data bytes specified by R4L or R4, starting from the address indicated by ER5, to the location starting at the address indicated by ER6. At the end of the transfer, the next instruction is executed.

2.6.4 Basic Instruction Formats

The H8/300H instructions consist of 2-byte (1-word) units. An instruction consists of an operation field (OP field), a register field (r field), an effective address extension (EA field), and a condition field (cc).

Operation Field: Indicates the function of the instruction, the addressing mode, and the operation to be carried out on the operand. The operation field always includes the first 4 bits of the instruction. Some instructions have two operation fields.

Register Field: Specifies a general register. Address registers are specified by 3 bits, data registers by 3 bits or 4 bits. Some instructions have two register fields. Some have no register field.

Effective Address Extension: Eight, 16, or 32 bits specifying immediate data, an absolute address, or a displacement. A 24-bit address or displacement is treated as 32-bit data in which the first 8 bits are 0 (H'00).

Condition Field: Specifies the branching condition of Bcc instructions.

Figure 2.9 shows examples of instruction formats.

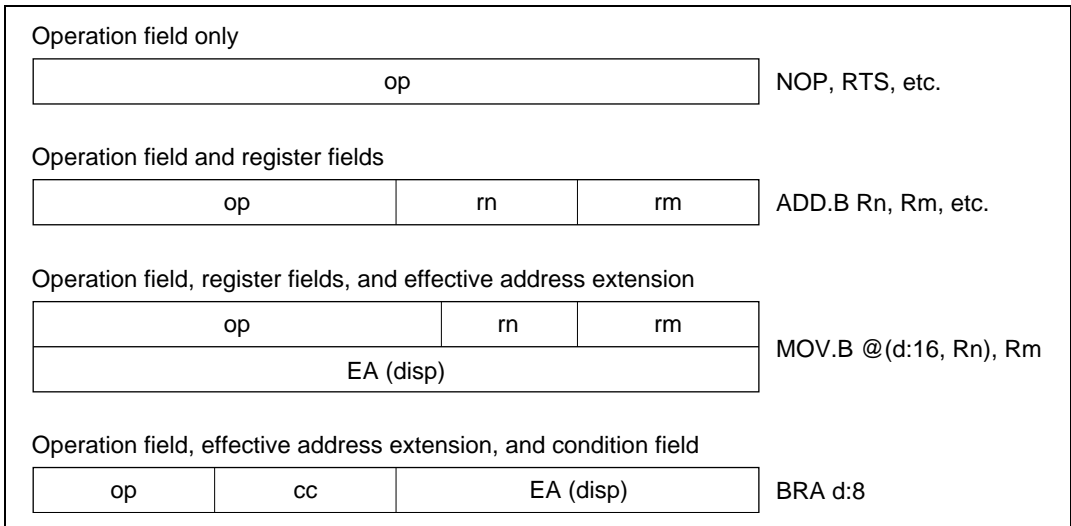

Figure 2.9 Instruction Formats

2.6.5 Notes on Use of Bit Manipulation Instructions

The BSET, BCLR, BNOT, BST, and BIST instructions read a byte of data, modify a bit in the byte, then write the byte back. Care is required when these instructions are used to access registers with write-only bits, or to access ports.

Step		Description
1	Read	Read one data byte at the specified address
2	Modify	Modify one bit in the data byte
3	Write	Write the modified data byte back to the specified address

Example 1: BCLR is executed to clear bit 0 in the port 4 data direction register (P4DDR) under the following conditions.

P4₇, P4₆: Input pins
P4₅ – P4₀: Output pins

The intended purpose of this BCLR instruction is to switch P4₀ from output to input.

Before Execution of BCLR Instruction

	P4 ₇	P4 ₆	P4 ₅	P4 ₄	P4 ₃	P4 ₂	P4 ₁	P4 ₀
Input/output	Input	Input	Output	Output	Output	Output	Output	Output
DDR	0	0	1	1	1	1	1	1

Execution of BCLR Instruction

BCLR #0, @P4DDR ;Clear bit 0 in data direction register

After Execution of BCLR Instruction

	P4 ₇	P4 ₆	P4 ₅	P4 ₄	P4 ₃	P4 ₂	P4 ₁	P4 ₀
Input/output	Output	Output	Output	Output	Output	Output	Output	Input
DDR	1	1	1	1	1	1	1	0

Explanation: To execute the BCLR instruction, the CPU begins by reading P4DDR. Since P4DDR is a write-only register, it is read as H'FF, even though its true value is H'3F.

Next the CPU clears bit 0 of the read data, changing the value to H'FE.

Finally, the CPU writes this value (H'FE) back to P4DDR to complete the BCLR instruction.

As a result, P4₀DDR is cleared to 0, making P4₀ an input pin. In addition, P4₇DDR and P4₆DDR are set to 1, making P4₇ and P4₆ output pins.

The BCLR instruction can be used to clear flags in the on-chip registers to 0. In an interrupt-handling routine, for example, if it is known that the flag is set to 1, it is not necessary to read the flag ahead of time.

2.7 Addressing Modes and Effective Address Calculation

2.7.1 Addressing Modes

The H8/300H CPU supports the eight addressing modes listed in table 2.11. Each instruction uses a subset of these addressing modes. Arithmetic and logic instructions can use the register direct and immediate modes. Data transfer instructions can use all addressing modes except program-counter relative and memory indirect. Bit manipulation instructions use register direct, register indirect, or absolute (@aa:8) addressing mode to specify an operand, and register direct (BSET, BCLR, BNOT, and BTST instructions) or immediate (3-bit) addressing mode to specify a bit number in the operand.

Table 2.11 Addressing Modes

No.	Addressing Mode	Symbol
1	Register direct	Rn
2	Register indirect	@ERn
3	Register indirect with displacement	@(d:16, ERn)/@(d:24, ERn)
4	Register indirect with post-increment Register indirect with pre-decrement	@ERn+ @-ERn
5	Absolute address	@aa:8/@aa:16/@aa:24
6	Immediate	#xx:8/#xx:16/#xx:32
7	Program-counter relative	@(d:8, PC)/@(d:16, PC)
8	Memory indirect	@@aa:8

1 Register Direct—Rn: The register field of the instruction code specifies an 8-, 16-, or 32-bit register containing the operand. R0H to R7H and R0L to R7L can be specified as 8-bit registers. R0 to R7 and E0 to E7 can be specified as 16-bit registers. ER0 to ER7 can be specified as 32-bit registers.

2 Register Indirect—@ERn: The register field of the instruction code specifies an address register (ERn), the lower 24 bits of which contain the address of the operand.

3 Register Indirect with Displacement—@(d:16, ERn) or @(d:24, ERn): A 16-bit or 24-bit displacement contained in the instruction code is added to the contents of an address register (ERn) specified by the register field of the instruction, and the lower 24 bits of the sum specify the address of a memory operand. A 16-bit displacement is sign-extended when added.

4 Register Indirect with Post-Increment or Pre-Decrement—@ERn+ or @-ERn:

- Register indirect with post-increment—@ERn+
The register field of the instruction code specifies an address register (ERn) the lower 24 bits of which contain the address of a memory operand. After the operand is accessed, 1, 2, or 4 is added to the address register contents (32 bits) and the sum is stored in the address register. The value added is 1 for byte access, 2 for word access, or 4 for longword access. For word or longword access, the register value should be even.
- Register indirect with pre-decrement—@-ERn
The value 1, 2, or 4 is subtracted from an address register (ERn) specified by the register field in the instruction code, and the lower 24 bits of the result become the address of a memory operand. The result is also stored in the address register. The value subtracted is 1 for byte access, 2 for word access, or 4 for longword access. For word or longword access, the resulting register value should be even.

5 Absolute Address—@aa:8, @aa:16, or @aa:24: The instruction code contains the absolute address of a memory operand. The absolute address may be 8 bits long (@aa:8), 16 bits long (@aa:16), or 24 bits long (@aa:24). For an 8-bit absolute address, the upper 16 bits are all assumed to be 1 (H'FFFF). For a 16-bit absolute address the upper 8 bits are a sign extension. A 24-bit absolute address can access the entire address space. Table 2.12 indicates the accessible address ranges.

Table 2.12 Absolute Address Access Ranges

Absolute Address	1-Mbyte Modes	16-Mbyte Modes
8 bits (@aa:8)	H'FFF00 to H'FFFFF (1048320 to 1048575)	H'FFFF00 to H'FFFFFF (16776960 to 16777215)
16 bits (@aa:16)	H'00000 to H'07FFF, H'F8000 to H'FFFFF (0 to 32767, 1015808 to 1048575)	H'000000 to H'007FFF, H'FF8000 to H'FFFFFF (0 to 32767, 16744448 to 16777215)
24 bits (@aa:24)	H'00000 to H'FFFFF (0 to 1048575)	H'000000 to H'FFFFFF (0 to 16777215)

6 Immediate—#xx:8, #xx:16, or #xx:32: The instruction code contains 8-bit (#xx:8), 16-bit (#xx:16), or 32-bit (#xx:32) immediate data as an operand.

The instruction codes of the ADDS, SUBS, INC, and DEC instructions contain immediate data implicitly. The instruction codes of some bit manipulation instructions contain 3-bit immediate data specifying a bit number. The TRAPA instruction code contains 2-bit immediate data specifying a vector address.

7 Program-Counter Relative—@(d:8, PC) or @(d:16, PC): This mode is used in the Bcc and BSR instructions. An 8-bit or 16-bit displacement contained in the instruction code is sign-extended to 24 bits and added to the 24-bit PC contents to generate a 24-bit branch address. The PC value to which the displacement is added is the address of the first byte of the next instruction, so the possible branching range is -126 to $+128$ bytes (-63 to $+64$ words) or -32766 to $+32768$ bytes (-16383 to $+16384$ words) from the branch instruction. The resulting value should be an even number.

8 Memory Indirect—@@aa:8: This mode can be used by the JMP and JSR instructions. The instruction code contains an 8-bit absolute address specifying a memory operand. This memory operand contains a branch address. The memory operand is accessed by longword access. The first byte of the memory operand is ignored, generating a 24-bit branch address. See figure 2.10. The upper bits of the 8-bit absolute address are assumed to be 0 (H'0000), so the address range is 0 to 255 (H'000000 to H'0000FF). Note that the first part of this range is also the exception vector area. For further details see section 5, Interrupt Controller.

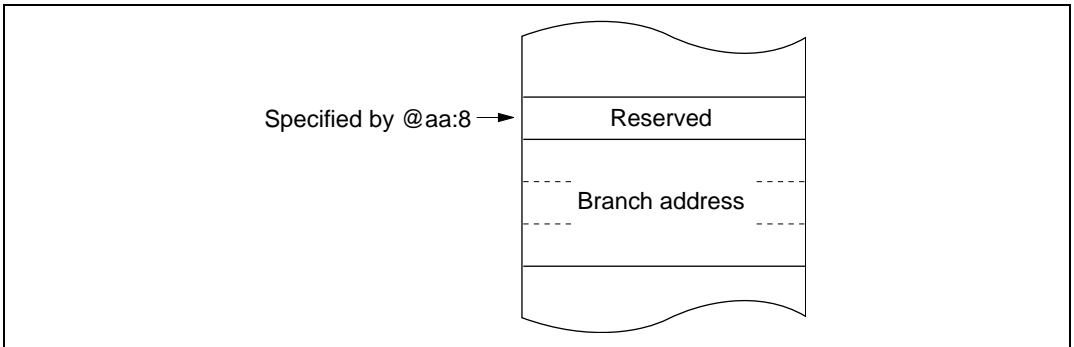

Figure 2.10 Memory-Indirect Branch Address Specification

When a word-size or longword-size memory operand is specified, or when a branch address is specified, if the specified memory address is odd, the least significant bit is regarded as 0. The accessed data or instruction code therefore begins at the preceding address. See section 2.5.2, Memory Data Formats.

2.7.2 Effective Address Calculation

Table 2.13 explains how an effective address is calculated in each addressing mode. In the 1-Mbyte operating modes the upper 4 bits of the calculated address are ignored in order to generate a 20-bit effective address.

Table 2.13 Effective Address Calculation

No.	Addressing Mode and Instruction Format	Effective Address Calculation	Effective Address													
1	Register direct (Rn) <div style="border: 1px solid black; padding: 2px; display: inline-block; margin: 5px;"> <table style="border-collapse: collapse;"> <tr> <td style="border: 1px solid black; padding: 2px;">op</td> <td style="border: 1px solid black; padding: 2px;">rm</td> <td style="border: 1px solid black; padding: 2px;">m</td> </tr> </table> </div>	op	rm	m	Operand is general register contents	<div style="border: 1px solid black; padding: 2px; display: inline-block; margin: 5px;"> <table style="border-collapse: collapse;"> <tr> <td style="border: 1px solid black; padding: 2px;">31</td> <td style="border: 1px solid black; padding: 2px;">General register contents</td> <td style="border: 1px solid black; padding: 2px;">0</td> </tr> </table> </div> <div style="border: 1px solid black; padding: 2px; display: inline-block; margin: 5px;"> <table style="border-collapse: collapse;"> <tr> <td style="border: 1px solid black; padding: 2px;">23</td> <td style="border: 1px solid black; padding: 2px;">Effective Address</td> <td style="border: 1px solid black; padding: 2px;">0</td> </tr> </table> </div>	31	General register contents	0	23	Effective Address	0				
op	rm	m														
31	General register contents	0														
23	Effective Address	0														
2	Register indirect with displacement <div style="border: 1px solid black; padding: 2px; display: inline-block; margin: 5px;"> <table style="border-collapse: collapse;"> <tr> <td style="border: 1px solid black; padding: 2px;">op</td> <td style="border: 1px solid black; padding: 2px;">r</td> </tr> </table> </div>	op	r	<div style="border: 1px solid black; padding: 2px; display: inline-block; margin: 5px;"> <table style="border-collapse: collapse;"> <tr> <td style="border: 1px solid black; padding: 2px;">31</td> <td style="border: 1px solid black; padding: 2px;">General register contents</td> <td style="border: 1px solid black; padding: 2px;">0</td> </tr> </table> </div> <div style="border: 1px solid black; padding: 2px; display: inline-block; margin: 5px;"> <table style="border-collapse: collapse;"> <tr> <td style="border: 1px solid black; padding: 2px;">31</td> <td style="border: 1px solid black; padding: 2px;">General register contents</td> <td style="border: 1px solid black; padding: 2px;">0</td> </tr> <tr> <td style="border: 1px solid black; padding: 2px;">23</td> <td style="border: 1px solid black; padding: 2px;">Sign extension</td> <td style="border: 1px solid black; padding: 2px;">disp</td> </tr> </table> </div> <div style="border: 1px solid black; padding: 2px; display: inline-block; margin: 5px;"> <table style="border-collapse: collapse;"> <tr> <td style="border: 1px solid black; padding: 2px;">23</td> <td style="border: 1px solid black; padding: 2px;">Effective Address</td> <td style="border: 1px solid black; padding: 2px;">0</td> </tr> </table> </div>	31	General register contents	0	31	General register contents	0	23	Sign extension	disp	23	Effective Address	0
op	r															
31	General register contents	0														
31	General register contents	0														
23	Sign extension	disp														
23	Effective Address	0														
3	Register indirect with displacement @d:16, ERn)/@(d:24, ERn) <div style="border: 1px solid black; padding: 2px; display: inline-block; margin: 5px;"> <table style="border-collapse: collapse;"> <tr> <td style="border: 1px solid black; padding: 2px;">op</td> <td style="border: 1px solid black; padding: 2px;">r</td> </tr> </table> </div>	op	r	<div style="border: 1px solid black; padding: 2px; display: inline-block; margin: 5px;"> <table style="border-collapse: collapse;"> <tr> <td style="border: 1px solid black; padding: 2px;">31</td> <td style="border: 1px solid black; padding: 2px;">General register contents</td> <td style="border: 1px solid black; padding: 2px;">0</td> </tr> </table> </div> <div style="border: 1px solid black; padding: 2px; display: inline-block; margin: 5px;"> <table style="border-collapse: collapse;"> <tr> <td style="border: 1px solid black; padding: 2px;">31</td> <td style="border: 1px solid black; padding: 2px;">General register contents</td> <td style="border: 1px solid black; padding: 2px;">0</td> </tr> <tr> <td style="border: 1px solid black; padding: 2px;">23</td> <td style="border: 1px solid black; padding: 2px;">Sign extension</td> <td style="border: 1px solid black; padding: 2px;">disp</td> </tr> </table> </div> <div style="border: 1px solid black; padding: 2px; display: inline-block; margin: 5px;"> <table style="border-collapse: collapse;"> <tr> <td style="border: 1px solid black; padding: 2px;">23</td> <td style="border: 1px solid black; padding: 2px;">Effective Address</td> <td style="border: 1px solid black; padding: 2px;">0</td> </tr> </table> </div>	31	General register contents	0	31	General register contents	0	23	Sign extension	disp	23	Effective Address	0
op	r															
31	General register contents	0														
31	General register contents	0														
23	Sign extension	disp														
23	Effective Address	0														
4	Register indirect with post-increment or pre-decrement Register indirect with post-increment @ERn+ <div style="border: 1px solid black; padding: 2px; display: inline-block; margin: 5px;"> <table style="border-collapse: collapse;"> <tr> <td style="border: 1px solid black; padding: 2px;">op</td> <td style="border: 1px solid black; padding: 2px;">r</td> </tr> </table> </div>	op	r	<div style="border: 1px solid black; padding: 2px; display: inline-block; margin: 5px;"> <table style="border-collapse: collapse;"> <tr> <td style="border: 1px solid black; padding: 2px;">31</td> <td style="border: 1px solid black; padding: 2px;">General register contents</td> <td style="border: 1px solid black; padding: 2px;">0</td> </tr> </table> </div> <div style="border: 1px solid black; padding: 2px; display: inline-block; margin: 5px;"> <table style="border-collapse: collapse;"> <tr> <td style="border: 1px solid black; padding: 2px;">23</td> <td style="border: 1px solid black; padding: 2px;">General register contents</td> <td style="border: 1px solid black; padding: 2px;">0</td> </tr> <tr> <td style="border: 1px solid black; padding: 2px;">23</td> <td style="border: 1px solid black; padding: 2px;">Sign extension</td> <td style="border: 1px solid black; padding: 2px;">1, 2, or 4</td> </tr> </table> </div> <div style="border: 1px solid black; padding: 2px; display: inline-block; margin: 5px;"> <table style="border-collapse: collapse;"> <tr> <td style="border: 1px solid black; padding: 2px;">23</td> <td style="border: 1px solid black; padding: 2px;">Effective Address</td> <td style="border: 1px solid black; padding: 2px;">0</td> </tr> </table> </div>	31	General register contents	0	23	General register contents	0	23	Sign extension	1, 2, or 4	23	Effective Address	0
op	r															
31	General register contents	0														
23	General register contents	0														
23	Sign extension	1, 2, or 4														
23	Effective Address	0														
	Register indirect with pre-decrement @-ERn <div style="border: 1px solid black; padding: 2px; display: inline-block; margin: 5px;"> <table style="border-collapse: collapse;"> <tr> <td style="border: 1px solid black; padding: 2px;">op</td> <td style="border: 1px solid black; padding: 2px;">r</td> </tr> </table> </div>	op	r	<div style="border: 1px solid black; padding: 2px; display: inline-block; margin: 5px;"> <table style="border-collapse: collapse;"> <tr> <td style="border: 1px solid black; padding: 2px;">31</td> <td style="border: 1px solid black; padding: 2px;">General register contents</td> <td style="border: 1px solid black; padding: 2px;">0</td> </tr> </table> </div> <div style="border: 1px solid black; padding: 2px; display: inline-block; margin: 5px;"> <table style="border-collapse: collapse;"> <tr> <td style="border: 1px solid black; padding: 2px;">23</td> <td style="border: 1px solid black; padding: 2px;">General register contents</td> <td style="border: 1px solid black; padding: 2px;">0</td> </tr> <tr> <td style="border: 1px solid black; padding: 2px;">23</td> <td style="border: 1px solid black; padding: 2px;">Sign extension</td> <td style="border: 1px solid black; padding: 2px;">1, 2, or 4</td> </tr> </table> </div> <div style="border: 1px solid black; padding: 2px; display: inline-block; margin: 5px;"> <table style="border-collapse: collapse;"> <tr> <td style="border: 1px solid black; padding: 2px;">23</td> <td style="border: 1px solid black; padding: 2px;">Effective Address</td> <td style="border: 1px solid black; padding: 2px;">0</td> </tr> </table> </div>	31	General register contents	0	23	General register contents	0	23	Sign extension	1, 2, or 4	23	Effective Address	0
op	r															
31	General register contents	0														
23	General register contents	0														
23	Sign extension	1, 2, or 4														
23	Effective Address	0														

1 for a byte operand,
2 for a word operand,
4 for a longword operand

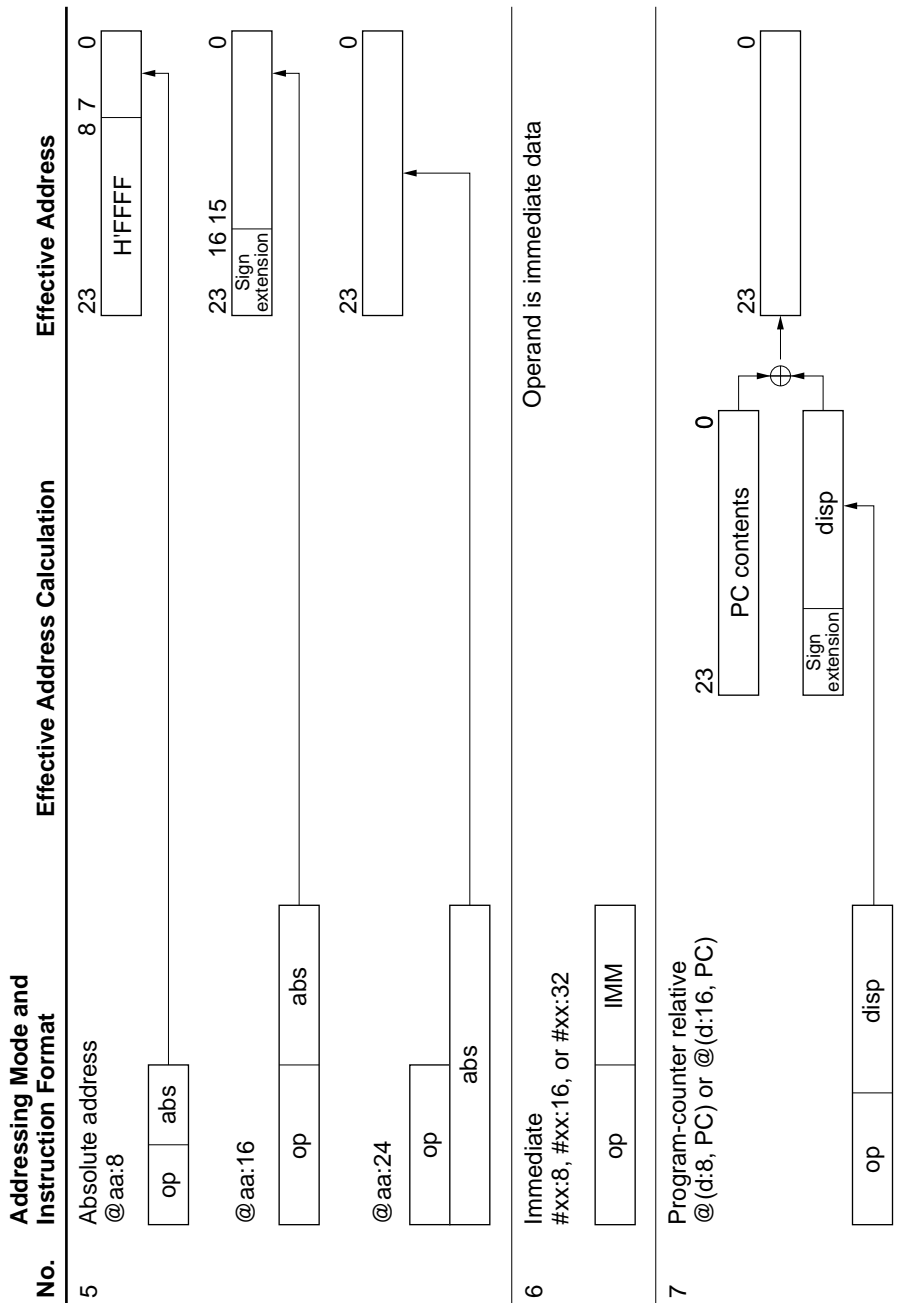

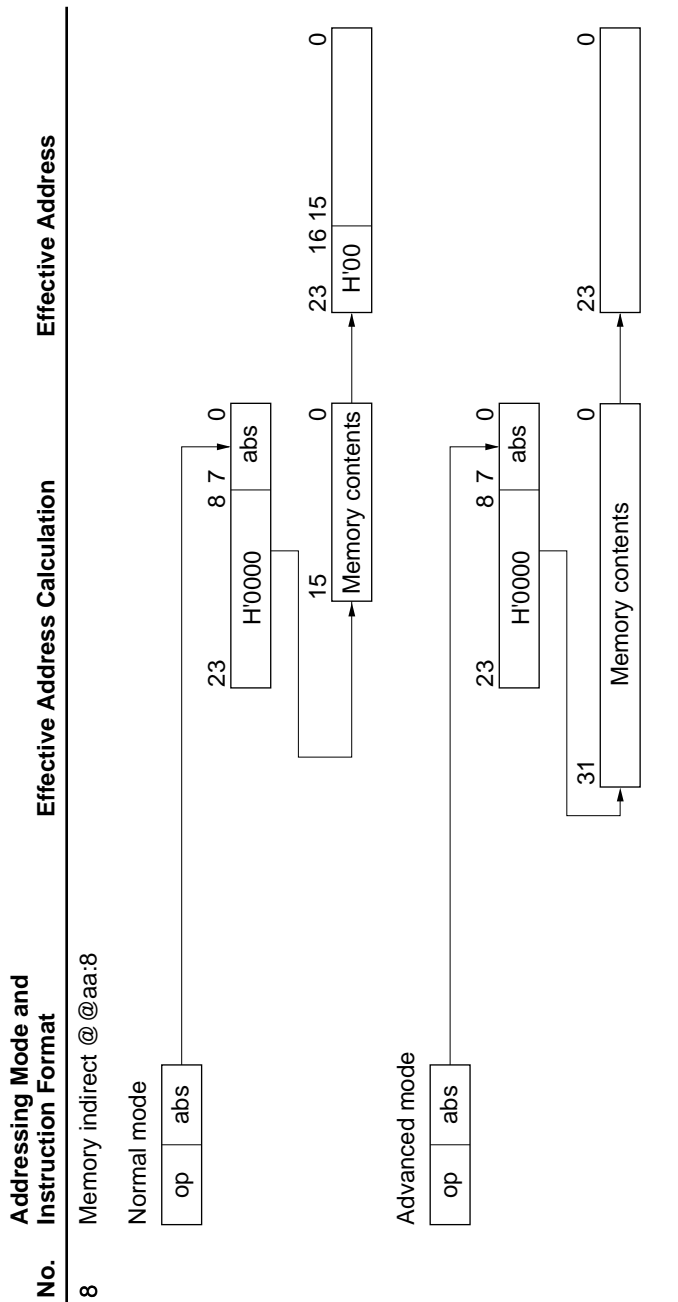

Legend

r, rm, rn: Register field
 op: Operation field
 disp: Displacement
 IMM: Immediate data
 abs: Absolute address

2.8 Processing States

2.8.1 Overview

The H8/300H CPU has five processing states: the program execution state, exception-handling state, power-down state, reset state, and bus-released state. The power-down state includes sleep mode, software standby mode, and hardware standby mode. Figure 2.11 classifies the processing states. Figure 2.13 indicates the state transitions.

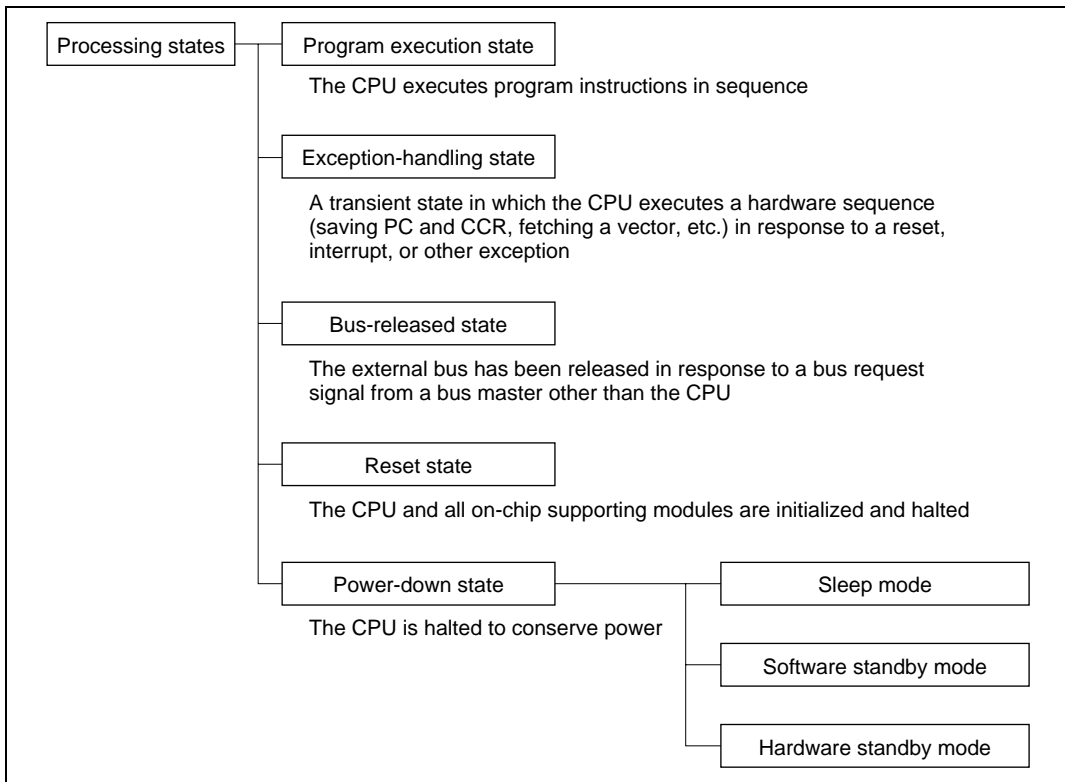

Figure 2.11 Processing States

2.8.2 Program Execution State

In this state the CPU executes program instructions in normal sequence.

2.8.3 Exception-Handling State

The exception-handling state is a transient state that occurs when the CPU alters the normal program flow due to a reset, interrupt, or trap instruction. The CPU fetches a starting address from the exception vector table and branches to that address. In interrupt and trap exception handling the CPU references the stack pointer (ER7) and saves the program counter and condition code register.

Types of Exception Handling and Their Priority: Exception handling is performed for resets, interrupts, and trap instructions. Table 2.14 indicates the types of exception handling and their priority. Trap instruction exceptions are accepted at all times in the program execution state.

Table 2.14 Exception Handling Types and Priority

Priority	Type of Exception	Detection Timing	Start of Exception Handling
High  Low	Reset	Synchronized with clock	Exception handling starts immediately when RES changes from low to high
	Interrupt	End of instruction execution or end of exception handling*	When an interrupt is requested, exception handling starts at the end of the current instruction or current exception-handling sequence
	Trap instruction	When TRAPA instruction is executed	Exception handling starts when a trap (TRAPA) instruction is executed

Note: * Interrupts are not detected at the end of the ANDC, ORC, XORC, and LDC instructions, or immediately after reset exception handling.

Figure 2.12 classifies the exception sources. For further details about exception sources, vector numbers, and vector addresses, see section 4, Exception Handling, and section 5, Interrupt Controller.

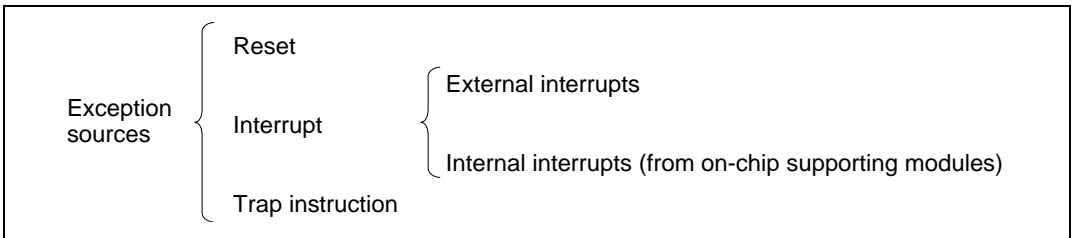

Figure 2.12 Classification of Exception Sources

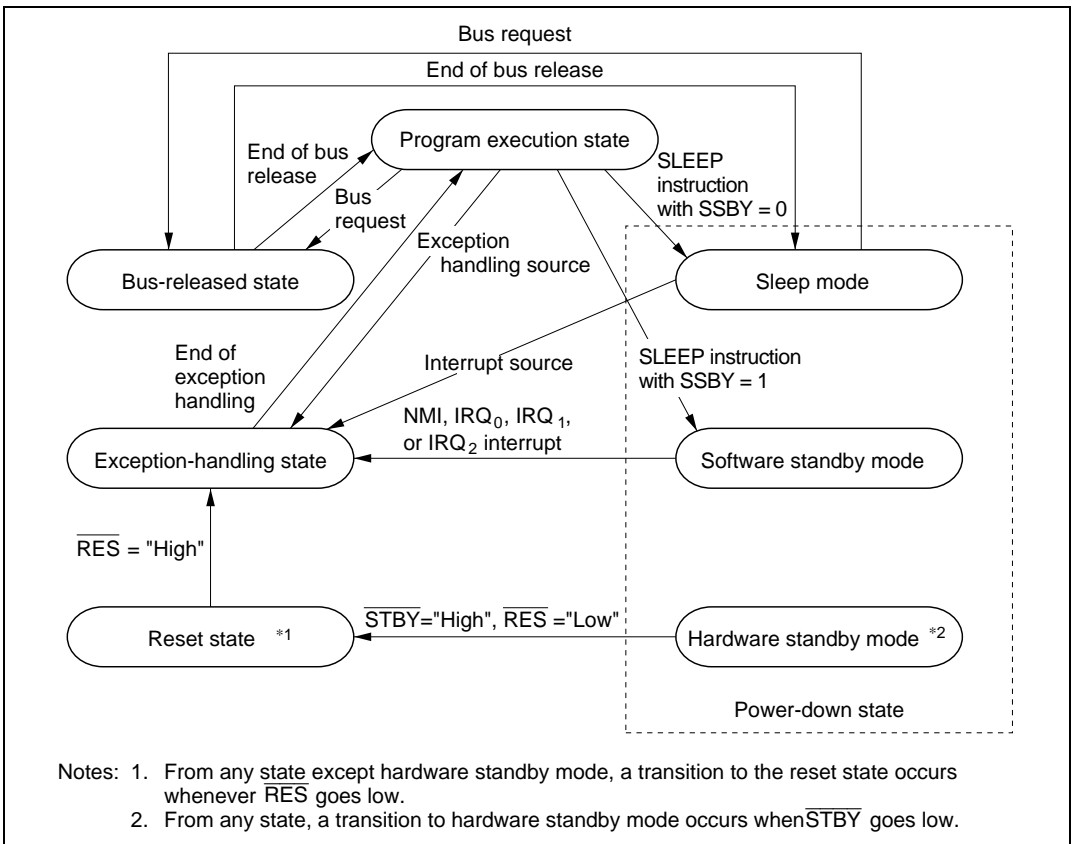

Figure 2.13 State Transitions

2.8.4 Exception-Handling Sequences

Reset Exception Handling: Reset exception handling has the highest priority. The reset state is entered when the $\overline{\text{RES}}$ signal goes low. Reset exception handling starts after that, when $\overline{\text{RES}}$ changes from low to high. When reset exception handling starts the CPU fetches a start address from the exception vector table and starts program execution from that address. All interrupts, including NMI, are disabled during the reset exception-handling sequence and immediately after it ends.

Interrupt Exception Handling and Trap Instruction Exception Handling: When these exception-handling sequences begin, the CPU references the stack pointer (ER7) and pushes the program counter and condition code register on the stack. Next, if the UE bit in the system control register (SYSCR) is set to 1, the CPU sets the I bit in the condition code register to 1. If the UE bit is cleared to 0, the CPU sets both the I bit and the UI bit in the condition code register to 1. Then the CPU fetches a start address from the exception vector table and execution branches to that address.

Figure 2.14 shows the stack after the exception-handling sequence.

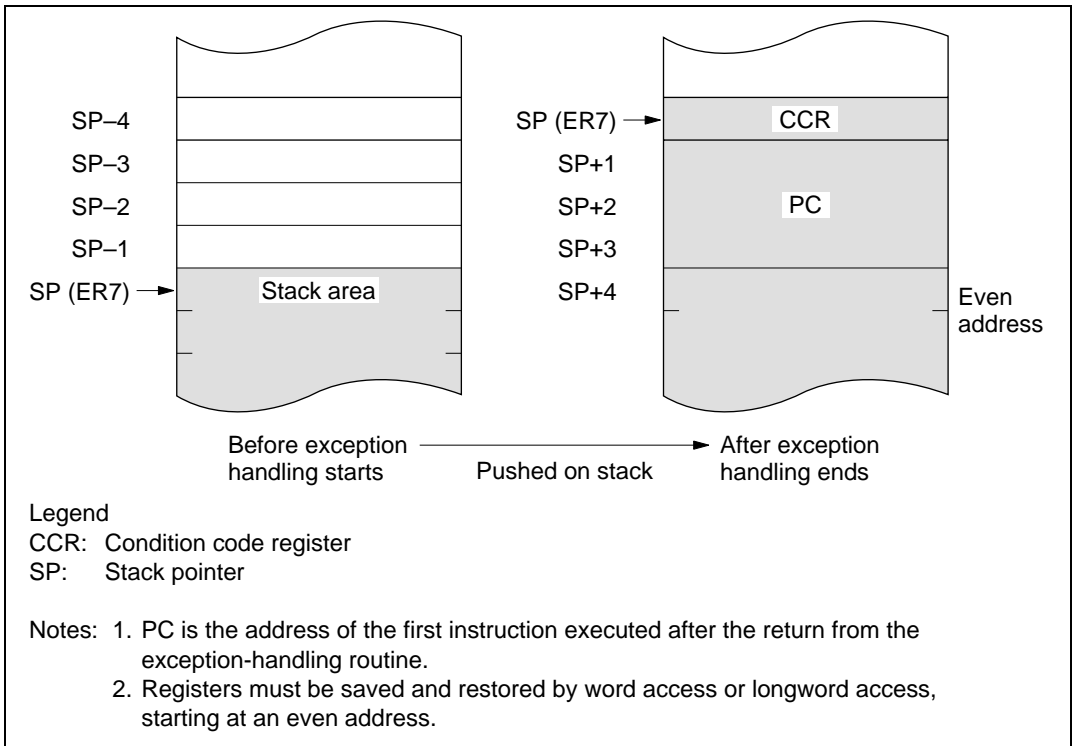

Figure 2.14 Stack Structure after Exception Handling

2.8.5 Bus-Released State

In this state the bus is released to a bus master other than the CPU, in response to a bus request. The bus masters other than the CPU are the DMA controller, the DRAM interface, and an external bus master. While the bus is released, the CPU halts except for internal operations. Interrupt requests are not accepted. For details see section 6.10, Bus Arbiter.

2.8.6 Reset State

When the $\overline{\text{RES}}$ input goes low all current processing stops and the CPU enters the reset state. The I bit in the condition code register is set to 1 by a reset. All interrupts are masked in the reset state. Reset exception handling starts when the $\overline{\text{RES}}$ signal changes from low to high.

The reset state can also be entered by a watchdog timer overflow. For details see section 12, Watchdog Timer.

2.8.7 Power-Down State

In the power-down state the CPU stops operating to conserve power. There are three modes: sleep mode, software standby mode, and hardware standby mode.

Sleep Mode: A transition to sleep mode is made if the SLEEP instruction is executed while the SSBY bit is cleared to 0 in the system control register (SYSCR). CPU operations stop immediately after execution of the SLEEP instruction, but the contents of CPU registers are retained.

Software Standby Mode: A transition to software standby mode is made if the SLEEP instruction is executed while the SSBY bit is set to 1 in SYSCR. The CPU and clock halt and all on-chip supporting modules stop operating. The on-chip supporting modules are reset, but as long as a specified voltage is supplied the contents of CPU registers and on-chip RAM are retained. The I/O ports also remain in their existing states.

Hardware Standby Mode: A transition to hardware standby mode is made when the $\overline{\text{STBY}}$ input goes low. As in software standby mode, the CPU and all clocks halt and the on-chip supporting modules are reset, but as long as a specified voltage is supplied, on-chip RAM contents are retained.

For further information see section 20, Power-Down State.

2.9 Basic Operational Timing

2.9.1 Overview

The H8/300H CPU operates according to the system clock (ϕ). The interval from one rise of the system clock to the next rise is referred to as a “state.” A memory cycle or bus cycle consists of two or three states. The CPU uses different methods to access on-chip memory, the on-chip supporting modules, and the external address space. Access to the external address space can be controlled by the bus controller.

2.9.2 On-Chip Memory Access Timing

On-chip memory is accessed in two states. The data bus is 16 bits wide, permitting both byte and word access. Figure 2.15 shows the on-chip memory access cycle. Figure 2.16 indicates the pin states.

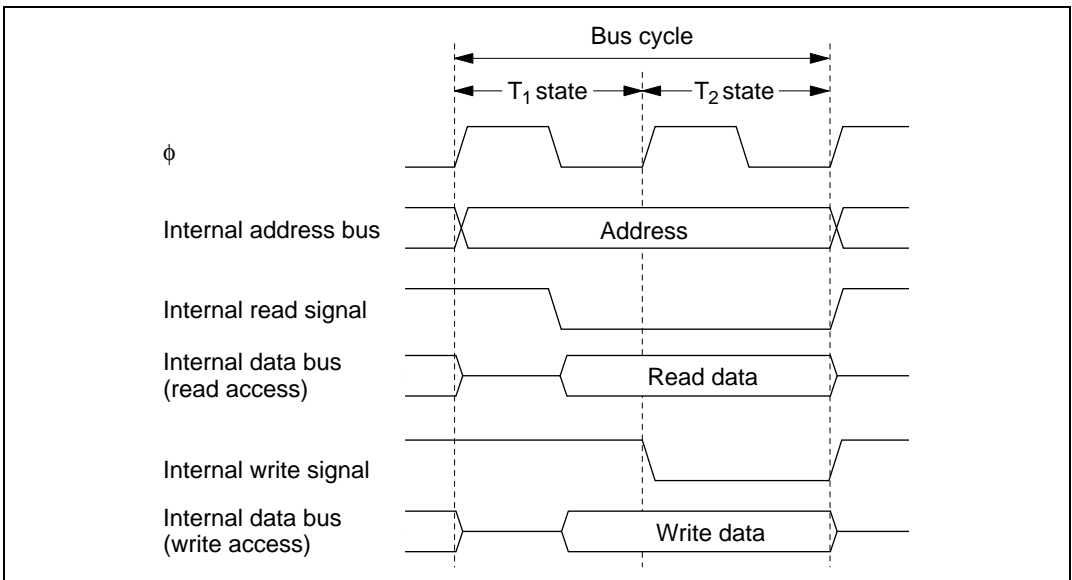

Figure 2.15 On-Chip Memory Access Cycle

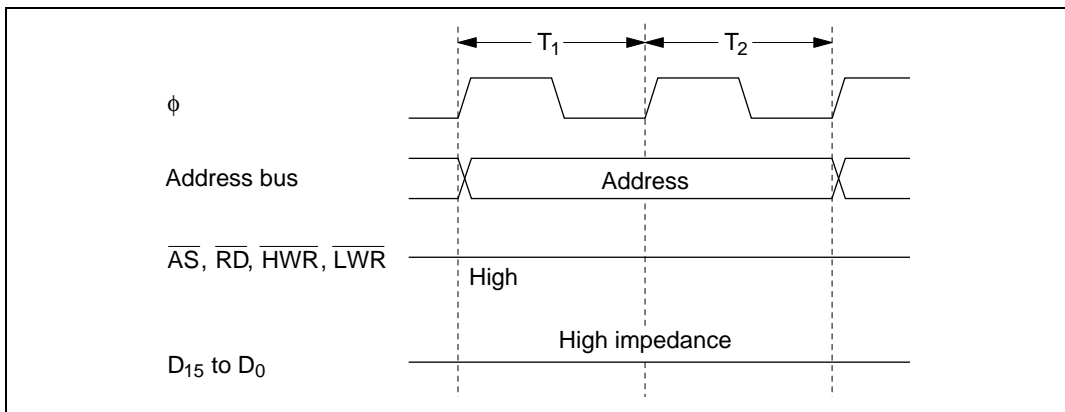

Figure 2.16 Pin States during On-Chip Memory Access

2.9.3 On-Chip Supporting Module Access Timing

The on-chip supporting modules are accessed in three states. The data bus is 8 or 16 bits wide, depending on the internal I/O register being accessed. Figure 2.17 shows the on-chip supporting module access timing. Figure 2.18 indicates the pin states.

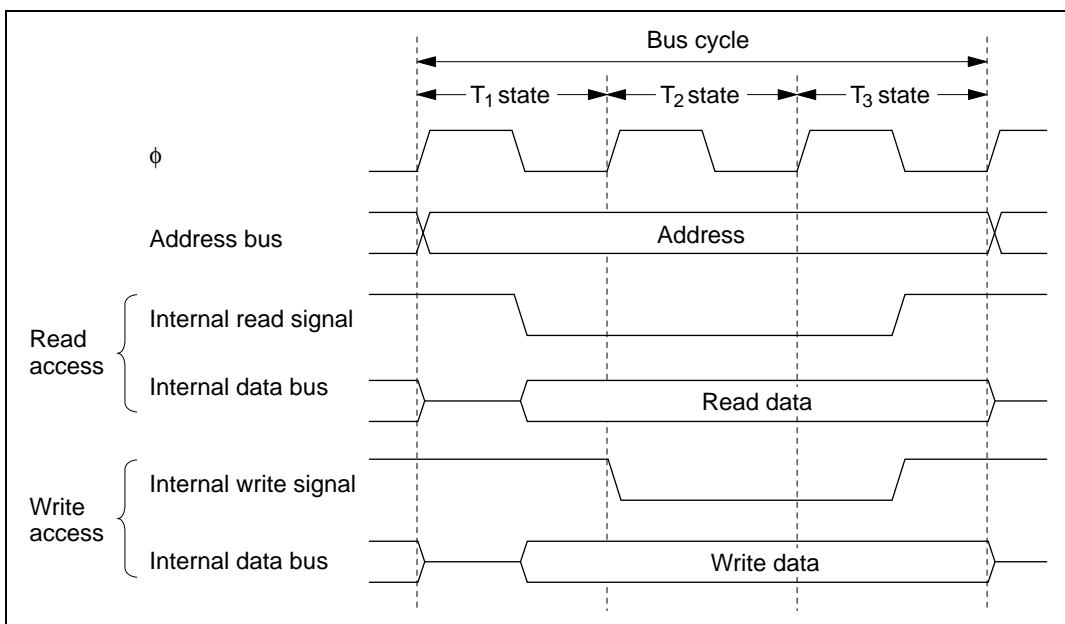

Figure 2.17 Access Cycle for On-Chip Supporting Modules

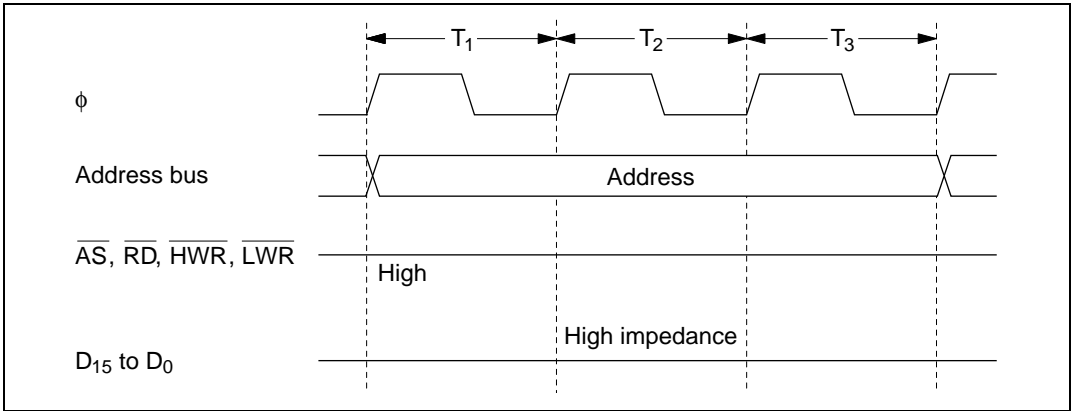

Figure 2.18 Pin States during Access to On-Chip Supporting Modules

2.9.4 Access to External Address Space

The external address space is divided into eight areas (areas 0 to 7). Bus-controller settings determine whether each area is accessed via an 8-bit or 16-bit bus, and whether it is accessed in two or three states. For details see section 6, Bus Controller.

Section 3 MCU Operating Modes

3.1 Overview

3.1.1 Operating Mode Selection

The H8/3068F has seven operating modes (modes 1 to 7) that are selected by the mode pins (MD₂ to MD₀) as indicated in table 3.1. The input at these pins determines the size of the address space and the initial bus mode.

Table 3.1 Operating Mode Selection

Operating Mode	Mode Pins			Address Space	Description		
	MD ₂	MD ₁	MD ₀		Initial Bus Mode* ¹	On-Chip ROM	On-Chip RAM
—	0	0	0	—	—	—	—
Mode 1	0	0	1	Expanded mode	8 bits	Disabled	Enabled* ²
Mode 2	0	1	0	Expanded mode	16 bits	Disabled	Enabled* ²
Mode 3	0	1	1	Expanded mode	8 bits	Disabled	Enabled* ²
Mode 4	1	0	0	Expanded mode	16 bits	Disabled	Enabled* ²
Mode 5	1	0	1	Expanded mode	8 bits	Enabled	Enabled* ²
Mode 6	1	1	0	Single-chip normal mode	—	Enabled	Enabled
Mode 7	1	1	1	Single-chip advanced mode	—	Enabled	Enabled

Notes: 1. In modes 1 to 5, an 8-bit or 16-bit data bus can be selected on a per-area basis by settings made in the area bus width control register (ABWCR). For details see section 6, Bus Controller.

2. If the RAME bit in SYSCR is cleared to 0, these addresses become external addresses.

For the address space size there are three choices: 64 kbytes, 1 Mbyte, or 16 Mbyte. The external data bus is either 8 or 16 bits wide depending on ABWCR settings. If 8-bit access is selected for all areas, 8-bit bus mode is used. For details see section 6, Bus Controller.

Modes 1 to 4 are externally expanded modes that enable access to external memory and peripheral devices and disable access to the on-chip ROM. Modes 1 and 2 support a maximum address space of 1 Mbyte. Modes 3 and 4 support a maximum address space of 16 Mbytes.

Mode 5 is an externally expanded mode that enables access to external memory and peripheral devices and also enables access to the on-chip ROM. Mode 5 supports a maximum address space of 16 Mbytes.

Modes 6 and 7 are single-chip modes that operate using the on-chip ROM, RAM, and registers, and makes all I/O ports available. Mode 6 supports a maximum address space of 64 kbytes. Mode 7 supports a maximum address space of 1 Mbyte.

The H8/3068F can be used only in modes 1 to 7. The inputs at the mode pins must select one of these seven modes. The inputs at the mode pins must not be changed during operation.

3.1.2 Register Configuration

The H8/3068F has a mode control register (MDCR) that indicates the inputs at the mode pins (MD_2 to MD_0), and a system control register (SYSCR). Table 3.2 summarizes these registers.

Table 3.2 Registers

Address*	Name	Abbreviation	R/W	Initial Value
H'EE011	Mode control register	MDCR	R	Undetermined
H'EE012	System control register	SYSCR	R/W	H'09

Note: * Lower 20 bits of the address in advanced mode.

3.2 Mode Control Register (MDCR)

MDCR is an 8-bit read-only register that indicates the current operating mode of the H8/3068F.

Bit	7	6	5	4	3	2	1	0
	—	—	—	—	—	MDS2	MDS1	MDS0
Initial value	1	1	0	0	0	—*	—*	—*
Read/Write	—	—	—	—	—	R	R	R

Reserved bits
Reserved bits
Mode select 2 to 0
Bits indicating the current operating mode

Note: * Determined by pins MD₂ to MD₀.

Bits 7 and 6—Reserved: These bits can not be modified and are always read as 1.

Bits 5 to 3—Reserved: These bits can not be modified and are always read as 0.

Bits 2 to 0—Mode Select 2 to 0 (MDS2 to MDS0): These bits indicate the logic levels at pins MD₂ to MD₀ (the current operating mode). MDS2 to MDS0 correspond to MD₂ to MD₀. MDS2 to MDS0 are read-only bits. The mode pin (MD₂ to MD₀) levels are latched into these bits when MDCR is read.

3.3 System Control Register (SYSCR)

SYSCR is an 8-bit register that controls the operation of the H8/3068F.

Bit	7	6	5	4	3	2	1	0
	SSBY	STS2	STS1	STS0	UE	NMIEG	SSOE	RAME
Initial value	0	0	0	0	1	0	0	1
Read/Write	R/W	R/W	R/W	R/W	R/W	R/W	R/W	R/W

RAM enable
Enables or disables on-chip RAM

Software standby output port enable
Selects the output state of the address bus and bus control signals in software standby mode

NMI edge select
Selects the valid edge of the NMI input

User bit enable
Selects whether to use the UI bit in CCR as a user bit or an interrupt mask bit

Standby timer select 2 to 0
These bits select the waiting time at recovery from software standby mode

Software standby
Enables transition to software standby mode

Bit 7—Software Standby (SSBY): Enables transition to software standby mode. (For further information about software standby mode see section 20, Power-Down State.)

When software standby mode is exited by an external interrupt, this bit remains set to 1. To clear this bit, write 0.

Bit 7

SSBY Description

0	SLEEP instruction causes transition to sleep mode	(Initial value)
1	SLEEP instruction causes transition to software standby mode	

Bits 6 to 4—Standby Timer Select 2 to 0 (STS2 to STS0): These bits select the length of time the CPU and on-chip supporting modules wait for the internal clock oscillator to settle when software standby mode is exited by an external interrupt.

When using a crystal oscillator, set these bits so that the waiting time will be at least 7 ms at the system clock rate.

For further information about waiting time selection, see section 20.4.3, Selection of Waiting Time for Exit from Software Standby Mode.

Bit 6 STS2	Bit 5 STS1	Bit 4 STS0	Description
0	0	0	Waiting time = 8,192 states (Initial value)
0	0	1	Waiting time = 16,384 states
0	1	0	Waiting time = 32,768 states
0	1	1	Waiting time = 65,536 states
1	0	0	Waiting time = 131,072 states
1	0	1	Waiting time = 262,144 states
1	1	0	Waiting time = 1,024 states
1	1	1	Illegal setting

Bit 3—User Bit Enable (UE): Selects whether to use the UI bit in the condition code register as a user bit or an interrupt mask bit.

Bit 3 UE	Description
0	UI bit in CCR is used as an interrupt mask bit
1	UI bit in CCR is used as a user bit (Initial value)

Bit 2—NMI Edge Select (NMIEG): Selects the valid edge of the NMI input.

Bit 2 NMIEG	Description
0	An interrupt is requested at the falling edge of NMI (Initial value)
1	An interrupt is requested at the rising edge of NMI

Bit 1—Software Standby Output Port Enable (SSOE): Specifies whether the address bus and bus control signals (\overline{CS}_0 to \overline{CS}_7 , \overline{AS} , \overline{RD} , \overline{HWR} , \overline{LWR} , \overline{UCAS} , \overline{LCAS} , and \overline{RFSH}) are kept as outputs or fixed high, or placed in the high-impedance state in software standby mode.

Bit 1

SSOE	Description
0	In software standby mode, the address bus and bus control signals are all high-impedance (Initial value)
1	In software standby mode, the address bus retains its output state and bus control signals are fixed high

Bit 0—RAM Enable (RAME): Enables or disables the on-chip RAM. The RAME bit is initialized by the rising edge of the \overline{RES} signal. It is not initialized in software standby mode.

Bit 0

RAME	Description
0	On-chip RAM is disabled
1	On-chip RAM is enabled (Initial value)

3.4 Operating Mode Descriptions

3.4.1 Mode 1

Ports 1, 2, and 5 function as address pins A_{19} to A_0 , permitting access to a maximum 1-Mbyte address space. The initial bus mode after a reset is 8 bits, with 8-bit access to all areas. If at least one area is designated for 16-bit access in ABWCR, the bus mode switches to 16 bits.

3.4.2 Mode 2

Ports 1, 2, and 5 function as address pins A_{19} to A_0 , permitting access to a maximum 1-Mbyte address space. The initial bus mode after a reset is 16 bits, with 16-bit access to all areas. If all areas are designated for 8-bit access in ABWCR, the bus mode switches to 8 bits.

3.4.3 Mode 3

Ports 1, 2, and 5 and part of port A function as address pins A_{23} to A_0 , permitting access to a maximum 16-Mbyte address space. The initial bus mode after a reset is 8 bits, with 8-bit access to all areas. If at least one area is designated for 16-bit access in ABWCR, the bus mode switches to

16 bits. A_{23} to A_{21} are valid when 0 is written in bits 7 to 5 of the bus release control register (BRCR). (In this mode A_{20} is always used for address output.)

3.4.4 Mode 4

Ports 1, 2, and 5 and part of port A function as address pins A_{23} to A_0 , permitting access to a maximum 16-Mbyte address space. The initial bus mode after a reset is 16 bits, with 16-bit access to all areas. If all areas are designated for 8-bit access in ABWCR, the bus mode switches to 8 bits. A_{23} to A_{21} are valid when 0 is written in bits 7 to 5 of BRCR. (In this mode A_{20} is always used for address output.)

3.4.5 Mode 5

Ports 1, 2, and 5 and part of port A can function as address pins A_{23} to A_0 , permitting access to a maximum 16-Mbyte address space, but following a reset they are input ports. To use ports 1, 2, and 5 as an address bus, the corresponding bits in their data direction registers (P1DDR, P2DDR, and P5DDR) must be set to 1. For A_{23} to A_{20} output, write 0 in bits 7 to 4 of BRCR. The initial bus mode after a reset is 8 bits, with 8-bit access to all areas. If at least one area is designated for 16-bit access in ABWCR, the bus mode switches to 16 bits.

3.4.6 Mode 6

This mode operates using the on-chip ROM, RAM, and registers. All I/O ports are available. Mode 6 supports a maximum address space of 64 kbytes.

3.4.7 Mode 7

This mode operates using the on-chip ROM, RAM, and registers. All I/O ports are available. Mode 7 supports a 1-Mbyte address space.

3.5 Pin Functions in Each Operating Mode

The pin functions of ports 1 to 5 and port A vary depending on the operating mode. Table 3.3 indicates their functions in each operating mode.

Table 3.3 Pin Functions in Each Mode

Port	Mode 1	Mode 2	Mode 3	Mode 4	Mode 5	Mode 6	Mode 7
Port 1	A ₇ to A ₀	A ₇ to A ₀	A ₇ to A ₀	A ₇ to A ₀	P ₁₇ to P ₁₀ * ²	P ₁₇ to P ₁₀	P ₁₇ to P ₁₀
Port 2	A ₁₅ to A ₈	A ₁₅ to A ₈	A ₁₅ to A ₈	A ₁₅ to A ₈	P ₂₇ to P ₂₀ * ²	P ₂₇ to P ₂₀	P ₂₇ to P ₂₀
Port 3	D ₁₅ to D ₈	D ₁₅ to D ₈	D ₁₅ to D ₈	D ₁₅ to D ₈	D ₁₅ to D ₈	P ₃₇ to P ₃₀	P ₃₇ to P ₃₀
Port 4	P ₄₇ to P ₄₀ * ¹	D ₇ to D ₀ * ¹	P ₄₇ to P ₄₀ * ¹	D ₇ to D ₀ * ¹	P ₄₇ to P ₄₀ * ¹	P ₄₇ to P ₄₀	P ₄₇ to P ₄₀
Port 5	A ₁₉ to A ₁₆	A ₁₉ to A ₁₆	A ₁₉ to A ₁₆	A ₁₉ to A ₁₆	P ₅₃ to P ₅₀ * ²	P ₅₃ to P ₅₀	P ₅₃ to P ₅₀
Port A	PA ₇ to PA ₄	PA ₇ to PA ₄	PA ₆ to PA ₄ , A ₂₀ * ³	PA ₆ to PA ₄ , A ₂₀ * ³	PA ₇ to PA ₄ * ⁴	PA ₇ to PA ₄	PA ₇ to PA ₄

- Notes:
1. Initial state. The bus mode can be switched by settings in ABWCR. These pins function as P₄₇ to P₄₀ in 8-bit bus mode, and as D₇ to D₀ in 16-bit bus mode.
 2. Initial state. These pins become address output pins when the corresponding bits in the data direction registers (P1DDR, P2DDR, P5DDR) are set to 1.
 3. Initial state. A₂₀ is always an address output pin. PA₆ to PA₄ are switched over to A₂₃ to A₂₁ output by writing 0 in bits 7 to 5 of BRCR.
 4. Initial state. PA₇ to PA₄ are switched over to A₂₃ to A₂₀ output by writing 0 in bits 7 to 4 of BRCR.

3.6 Memory Map in Each Operating Mode

Figure 3.1 to 3.2 show a memory maps of the H8/3068F. The address space is divided into eight areas.

The EMC bit in BCR can be read and written to select either of the two memory maps. For details, see section 6.2.5, Bus Control Register (BCR).

The initial bus mode differs between modes 1 and 2, and also between modes 3 and 4.

The address locations of the on-chip RAM and on-chip registers differ between the 64-kbyte mode (mode 6), the 1-Mbyte modes (modes 1, 2, and 7), and the 16-Mbyte modes (modes 3, 4, and 5). The address range specifiable by the CPU in the 8- and 16-bit absolute addressing modes (@aa:8 and @aa:16) also differs.

3.6.1 Note on Reserved Areas

The H8/3068F memory map includes reserved areas to which read/write access is prohibited. Note that normal operation is not guaranteed if the following reserved areas are accessed.

The reserved area in the internal I/O register space.

The H8/3068F internal I/O register space includes a reserved area to which access is prohibited. For details see Appendix B, Internal I/O Registers.

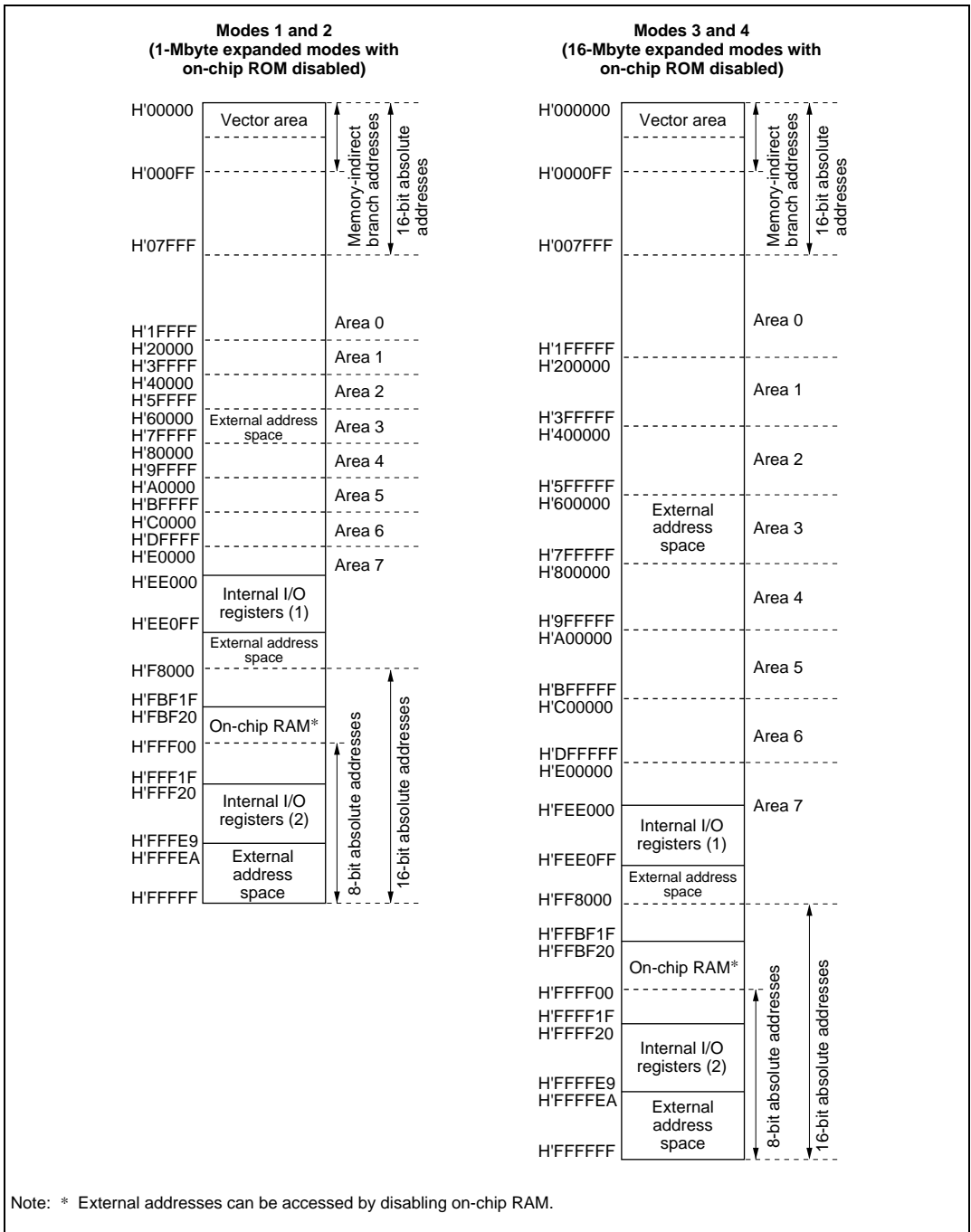

Figure 3.1(1) H8/3068F Memory Map in Each Operating Mode

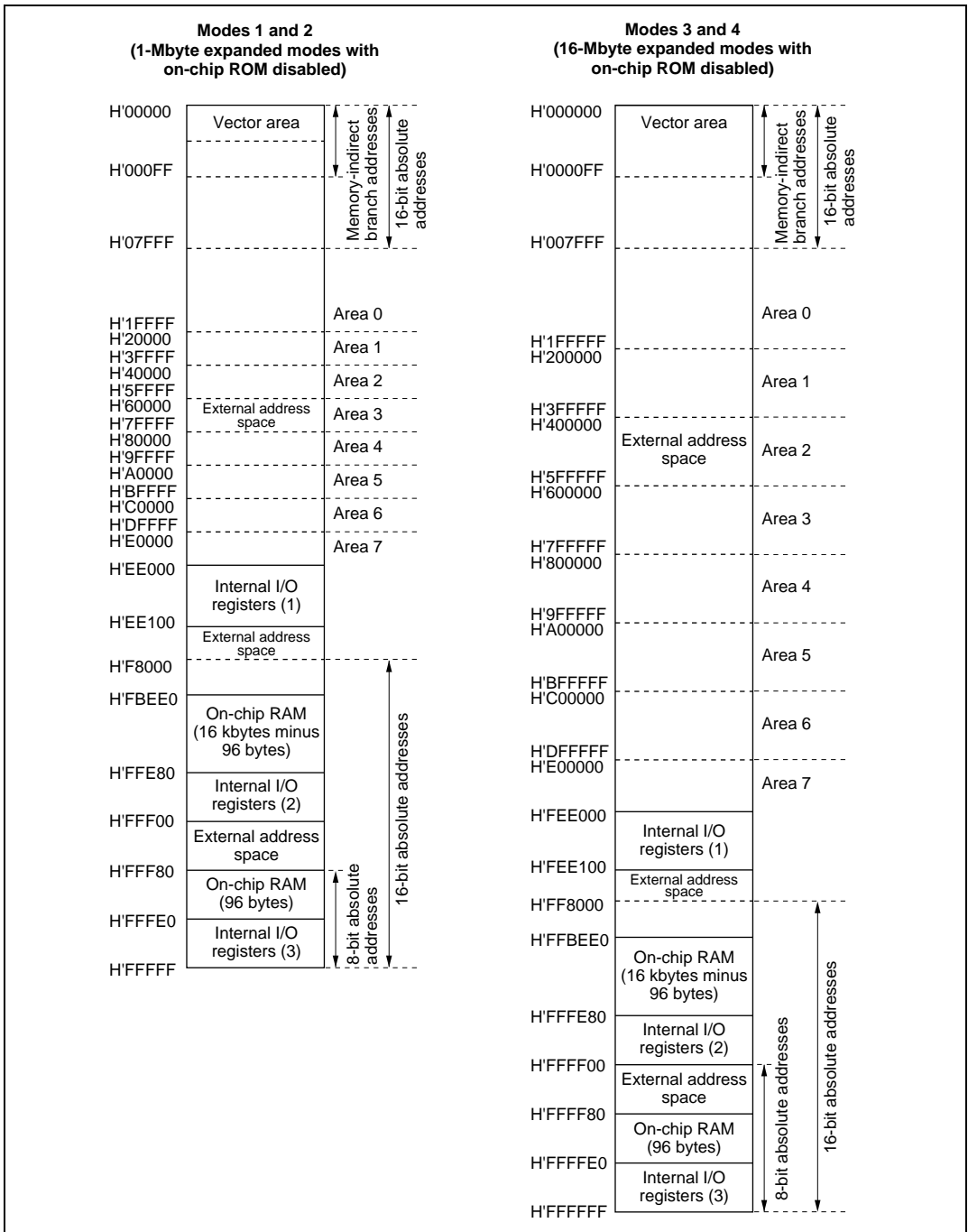

Figure 3.2(1) H8/3068F Memory Map in Each Operating Mode (EMC = 0)

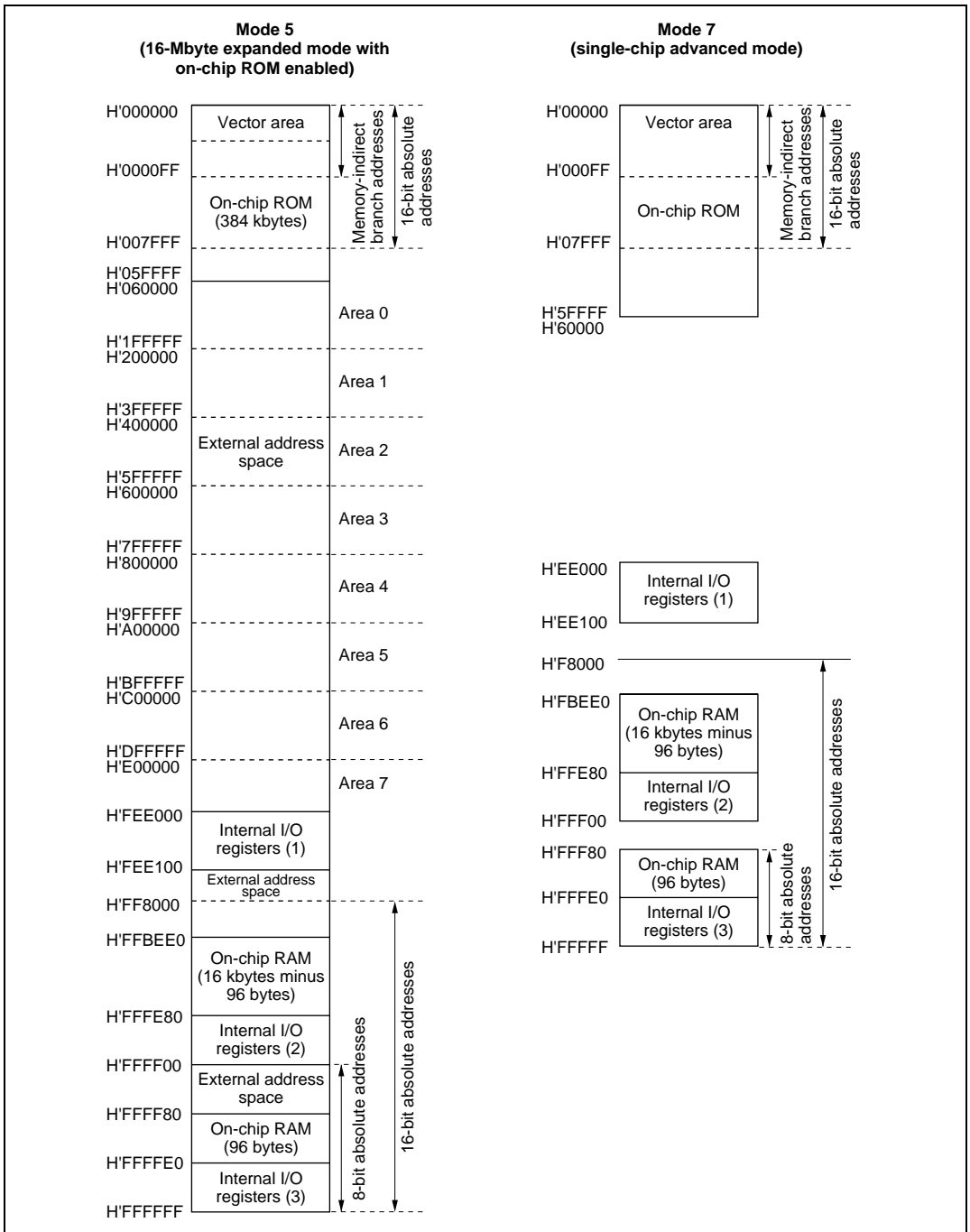

Figure 3.2(2) H8/3068F Memory Map in Each Operating Mode (EMC = 0)

Section 4 Exception Handling

4.1 Overview

4.1.1 Exception Handling Types and Priority

As table 4.1 indicates, exception handling may be caused by a reset, trap instruction, or interrupt. Exception handling is prioritized as shown in table 4.1. If two or more exceptions occur simultaneously, they are accepted and processed in priority order. Trap instruction exceptions are accepted at all times in the program execution state.

Table 4.1 Exception Types and Priority

Priority	Exception Type	Start of Exception Handling
High	Reset	Starts immediately after a low-to-high transition at the $\overline{\text{RES}}$ pin
↑	Interrupt	Interrupt requests are handled when execution of the current instruction or handling of the current exception is completed
Low	Trap instruction (TRAPA)	Started by execution of a trap instruction (TRAPA)

4.1.2 Exception Handling Operation

Exceptions originate from various sources. Trap instructions and interrupts are handled as follows.

1. The program counter (PC) and condition code register (CCR) are pushed onto the stack.
2. The CCR interrupt mask bit is set to 1.
3. A vector address corresponding to the exception source is generated, and program execution starts from that address.

For a reset exception, steps 2 and 3 above are carried out.

4.1.3 Exception Vector Table

The exception sources are classified as shown in figure 4.1. Different vectors are assigned to different exception sources. Table 4.2 lists the exception sources and their vector addresses.

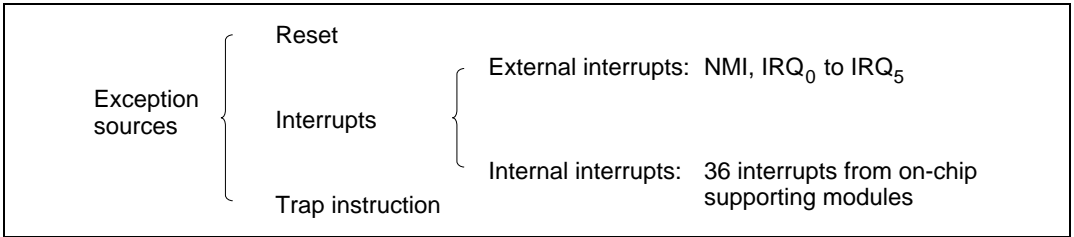

Figure 4.1 Exception Sources

Table 4.2 Exception Vector Table

Exception Source	Vector Number	Vector Address* ¹	
		Advanced Mode	Normal Mode
Reset	0	H'0000 to H'0003	H'0000 to H'0001
Reserved for system use	1	H'0004 to H'0007	H'0002 to H'0003
	2	H'0008 to H'000B	H'0004 to H'0005
	3	H'000C to H'000F	H'0006 to H'0007
	4	H'0010 to H'0013	H'0008 to H'0009
	5	H'0014 to H'0017	H'000A to H'000B
	6	H'0018 to H'001B	H'000C to H'000D
External interrupt (NMI)	7	H'001C to H'001F	H'000E to H'000F
Trap instruction (4 sources)	8	H'0020 to H'0023	H'0010 to H'0011
	9	H'0024 to H'0027	H'0012 to H'0013
	10	H'0028 to H'002B	H'0014 to H'0015
	11	H'002C to H'002F	H'0016 to H'0017
External interrupt IRQ ₀	12	H'0030 to H'0033	H'0018 to H'0019
External interrupt IRQ ₁	13	H'0034 to H'0037	H'001A to H'001B
External interrupt IRQ ₂	14	H'0038 to H'003B	H'001C to H'001D
External interrupt IRQ ₃	15	H'003C to H'003F	H'001E to H'001F
External interrupt IRQ ₄	16	H'0040 to H'0043	H'0020 to H'0021
External interrupt IRQ ₅	17	H'0044 to H'0047	H'0022 to H'0023
Reserved for system use	18	H'0048 to H'004B	H'0024 to H'0025
	19	H'004C to H'004F	H'0026 to H'0027
Internal interrupts* ²	20	H'0050 to H'0053	H'0028 to H'0029
	to	to	to
	63	H'00FC to H'00FF	H'007E to H'007F

Notes: 1. Lower 16 bits of the address.

2. For the internal interrupt vectors, see section 5.3.3, Interrupt Vector Table.

4.2 Reset

4.2.1 Overview

A reset is the highest-priority exception. When the $\overline{\text{RES}}$ pin goes low, all processing halts and the chip enters the reset state. A reset initializes the internal state of the CPU and the registers of the on-chip supporting modules. Reset exception handling begins when the $\overline{\text{RES}}$ pin changes from low to high.

The chip can also be reset by overflow of the watchdog timer. For details see section 12, Watchdog Timer.

4.2.2 Reset Sequence

The chip enters the reset state when the $\overline{\text{RES}}$ pin goes low.

To ensure that the chip is reset, hold the $\overline{\text{RES}}$ pin low for at least 20 ms at power-up. To reset the chip during operation, hold the $\overline{\text{RES}}$ pin low for at least 10 system clock (ϕ) cycles. When the flash memory and flash memory R versions are used, the $\overline{\text{RES}}$ pin must be held low for at least 20 system clock cycles. See appendix D.2, Pin States at Reset, for the states of the pins in the reset state.

When the $\overline{\text{RES}}$ pin goes high after being held low for the necessary time, the chip starts reset exception handling as follows.

- The internal state of the CPU and the registers of the on-chip supporting modules are initialized, and the I bit is set to 1 in CCR.
- The contents of the reset vector address (H'0000 to H'0003 in advanced mode, H'0000 to H'0001 in normal mode) are read, and program execution starts from the address indicated in the vector address.

Figure 4.2 shows the reset sequence in modes 1 and 3. Figure 4.3 shows the reset sequence in modes 2 and 4. Figure 4.4 shows the reset sequence in mode 6.

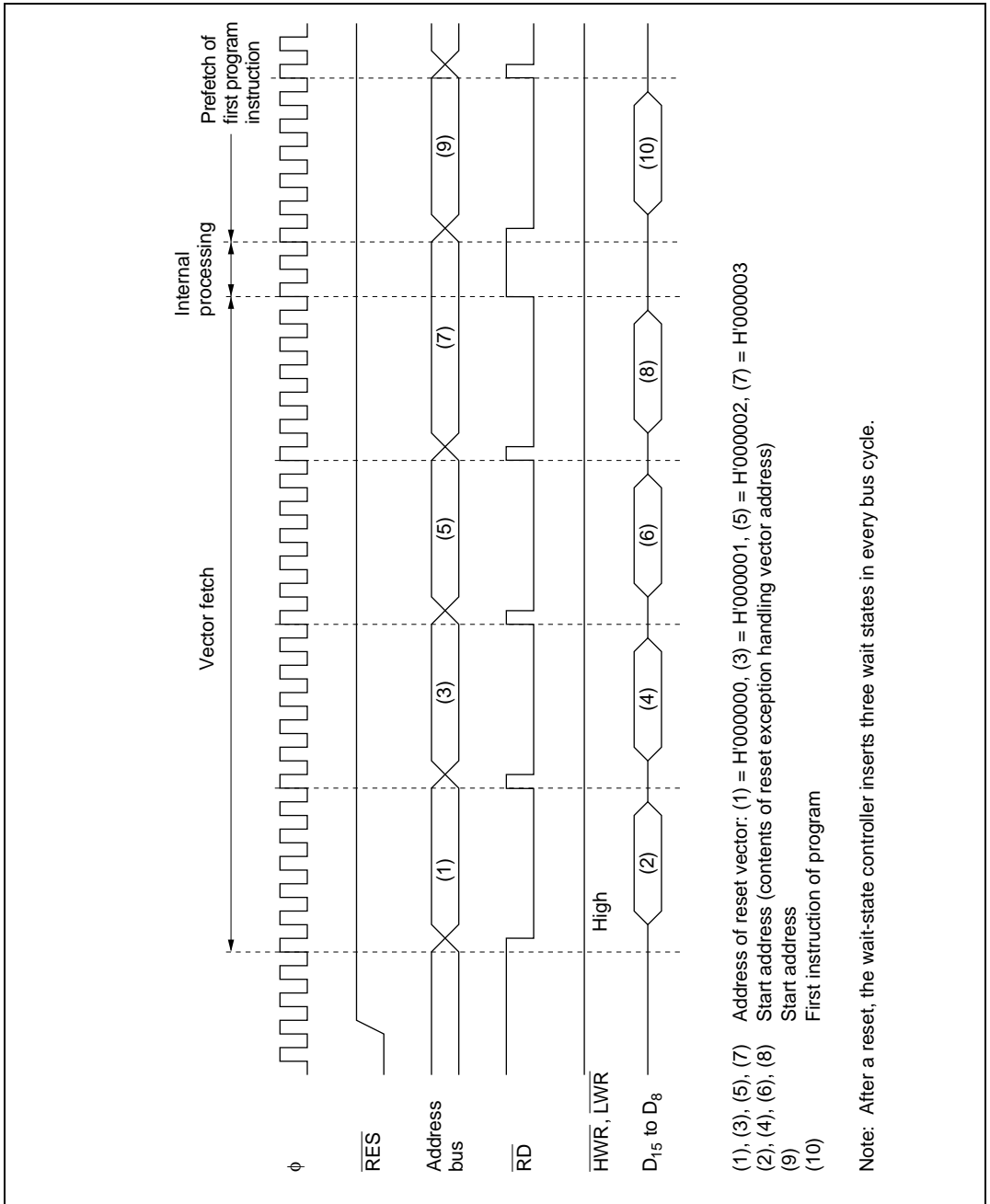

Figure 4.2 Reset Sequence (Modes 1 and 3)

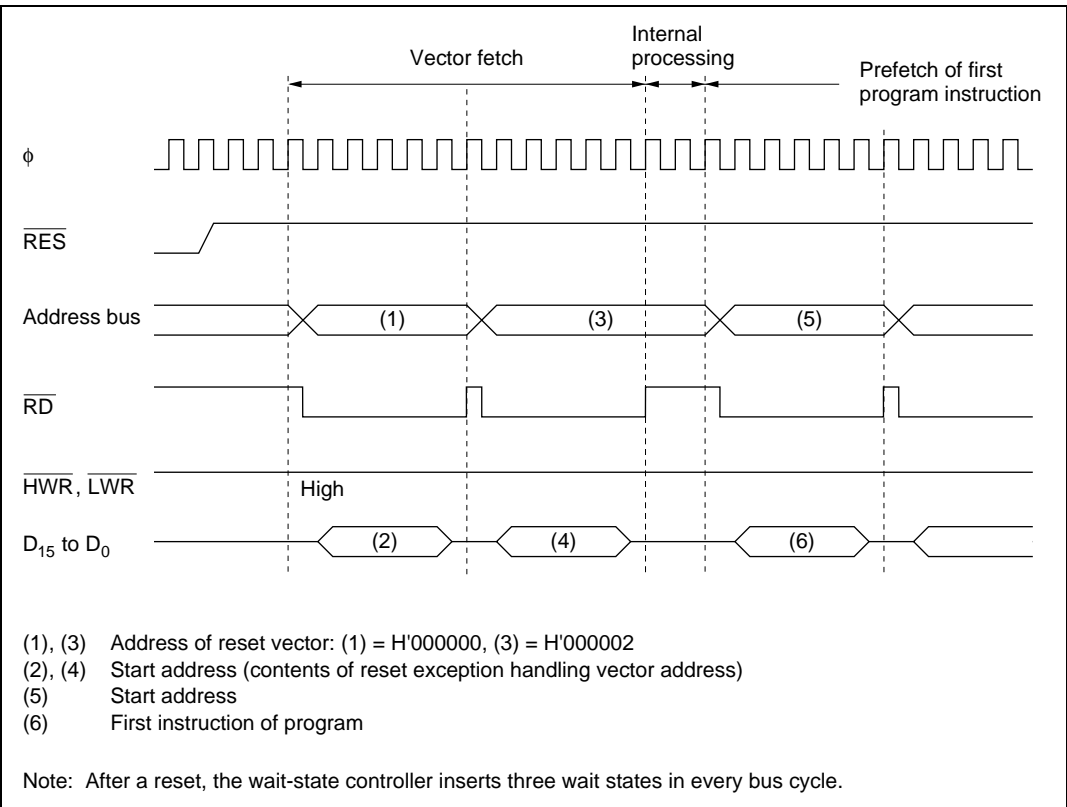

Figure 4.3 Reset Sequence (Modes 2 and 4)

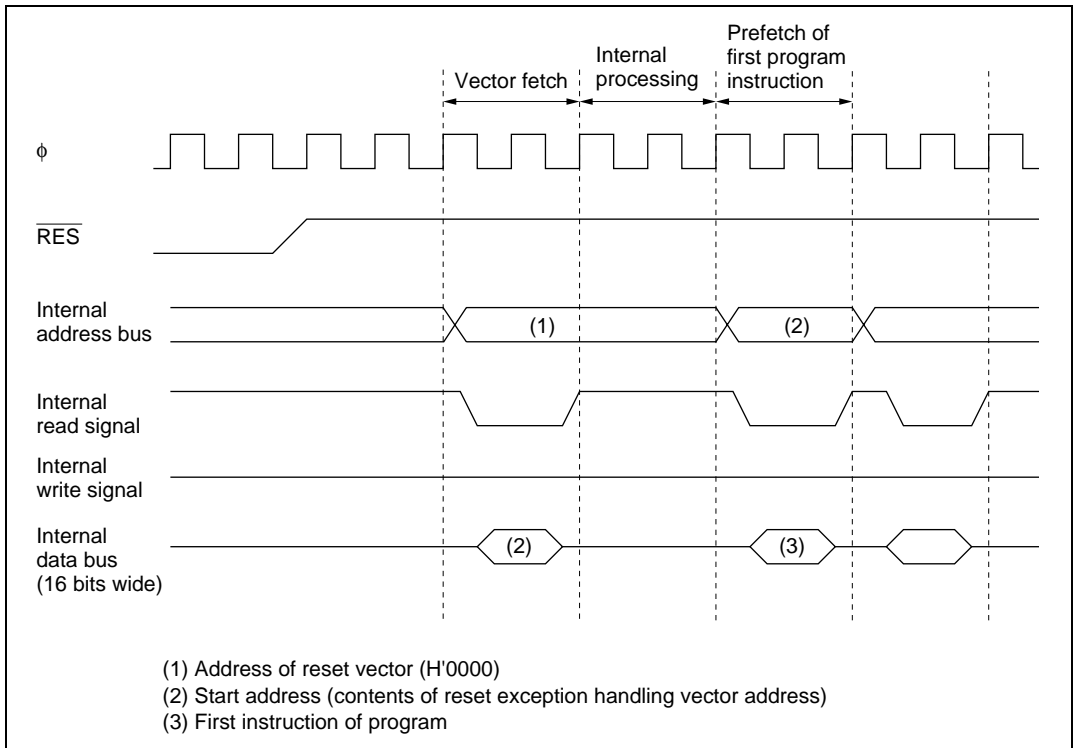

Figure 4.4 Reset Sequence (Mode 6)

4.2.3 Interrupts after Reset

If an interrupt is accepted after a reset but before the stack pointer (SP) is initialized, PC and CCR will not be saved correctly, leading to a program crash. To prevent this, all interrupt requests, including NMI, are disabled immediately after a reset. The first instruction of the program is always executed immediately after the reset state ends. This instruction should initialize the stack pointer (example: `MOV.L #xx:32, SP`).

4.3 Interrupts

Interrupt exception handling can be requested by seven external sources (NMI, IRQ₀ to IRQ₅), and 36 internal sources in the on-chip supporting modules. Figure 4.5 classifies the interrupt sources and indicates the number of interrupts of each type.

The on-chip supporting modules that can request interrupts are the watchdog timer (WDT), DRAM interface, 16-bit timer, 8-bit timer, DMA controller (DMAC), serial communication interface (SCI), and A/D converter. Each interrupt source has a separate vector address.

NMI is the highest-priority interrupt and is always accepted*. Interrupts are controlled by the interrupt controller. The interrupt controller can assign interrupts other than NMI to two priority levels, and arbitrate between simultaneous interrupts. Interrupt priorities are assigned in interrupt priority registers A and B (IPRA and IPRB) in the interrupt controller.

Note: * In the flash memory and flash memory R versions, NMI input is sometimes disabled. For details see section 18.9, NMI Input Disable Conditions.

For details on interrupts see section 5, Interrupt Controller.

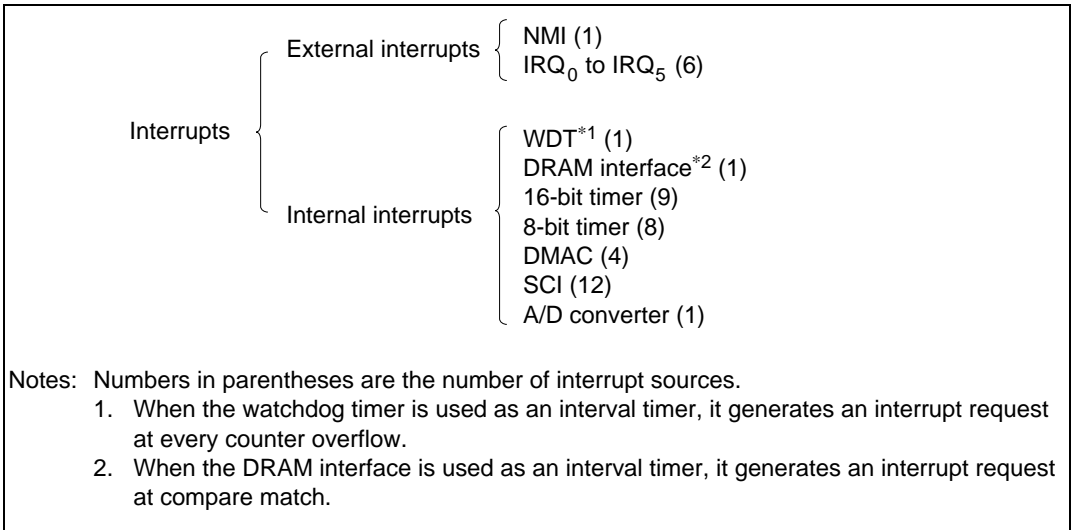

Figure 4.5 Interrupt Sources and Number of Interrupts

4.4 Trap Instruction

Trap instruction exception handling starts when a TRAPA instruction is executed. If the UE bit is set to 1 in the system control register (SYSCR), the exception handling sequence sets the I bit to 1 in CCR. If the UE bit is 0, the I and UI bits are both set to 1. The TRAPA instruction fetches a start address from a vector table entry corresponding to a vector number from 0 to 3, which is specified in the instruction code.

4.5 Stack Status after Exception Handling

Figure 4.6 shows the stack after completion of trap instruction exception handling and interrupt exception handling.

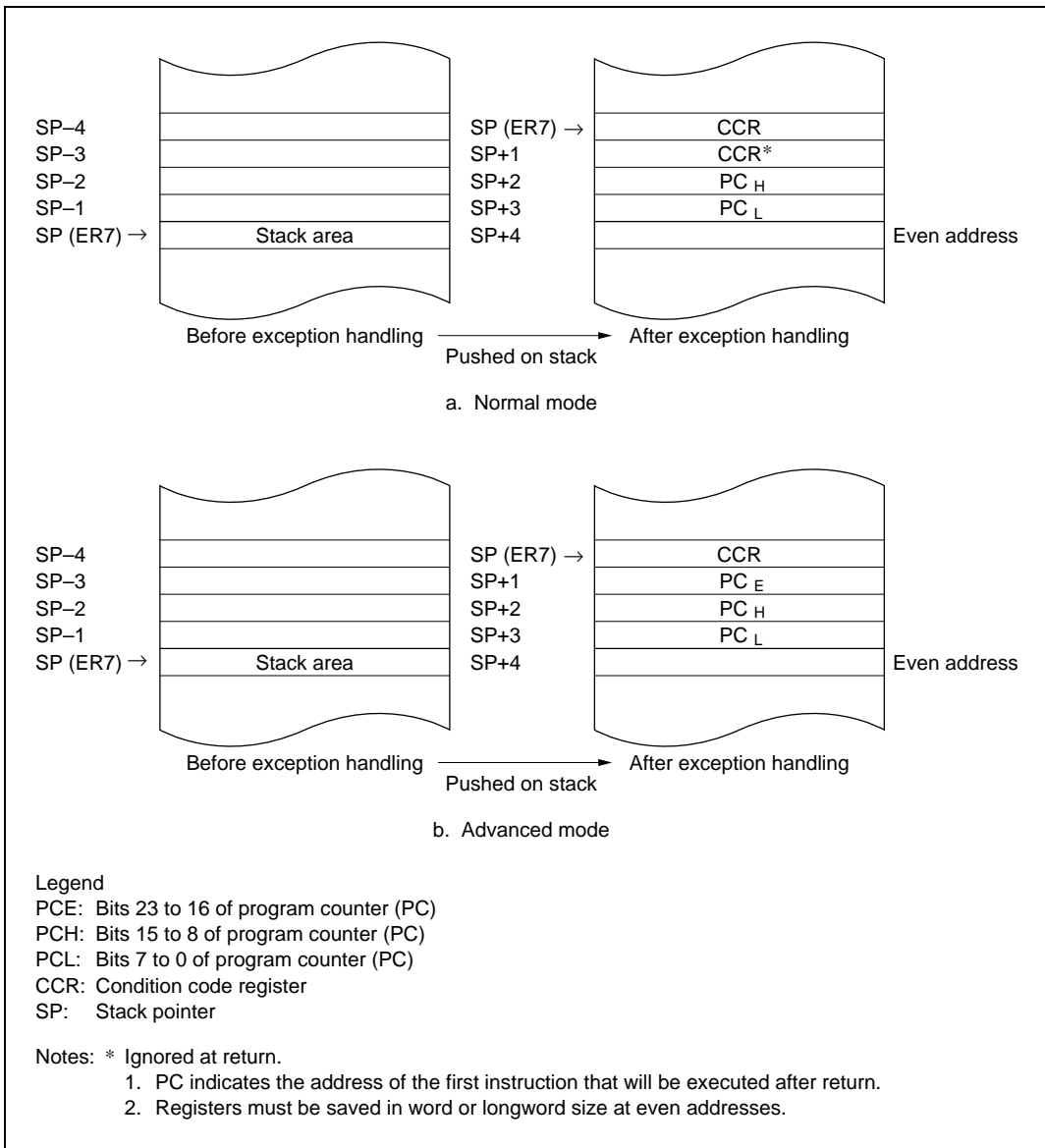

Figure 4.6 Stack after Completion of Exception Handling

4.6 Notes on Stack Usage

When accessing word data or longword data, the H8/3068F regards the lowest address bit as 0. The stack should always be accessed by word access or longword access, and the value of the stack pointer (SP, ER7) should always be kept even.

Use the following instructions to save registers:

PUSH.W Rn (or MOV.W Rn, @-SP)

PUSH.L ERn (or MOV.L ERn, @-SP)

Use the following instructions to restore registers:

POP.W Rn (or MOV.W @SP+, Rn)

POP.L ERn (or MOV.L @SP+, ERn)

Setting SP to an odd value may lead to a malfunction. Figure 4.7 shows an example of what happens when the SP value is odd.

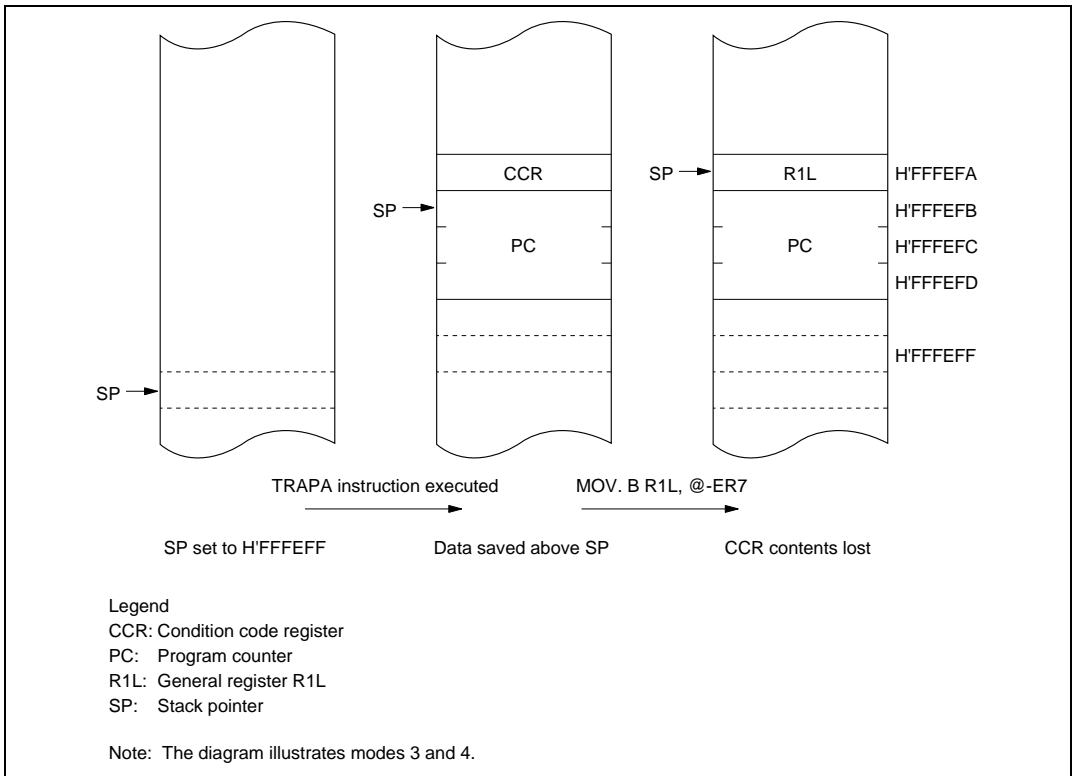

Figure 4.7 Operation when SP Value is Odd

Section 5 Interrupt Controller

5.1 Overview

5.1.1 Features

The interrupt controller has the following features:

- Interrupt priority registers (IPRs) for setting interrupt priorities
- Interrupts other than NMI can be assigned to two priority levels on a module-by-module basis in interrupt priority registers A and B (IPRA and IPRB).
- Three-level masking by the I and UI bits in the CPU condition code register (CCR)
- Seven external interrupt pins

NMI has the highest priority and is always accepted*; either the rising or falling edge can be selected. For each of IRQ₀ to IRQ₅, sensing of the falling edge or level sensing can be selected independently.

Note: * In the flash memory and flash memory R versions, NMI input is sometimes disabled. For details see section 18.9, NMI Input Disable Conditions.

5.1.2 Block Diagram

Figure 5.1 shows a block diagram of the interrupt controller.

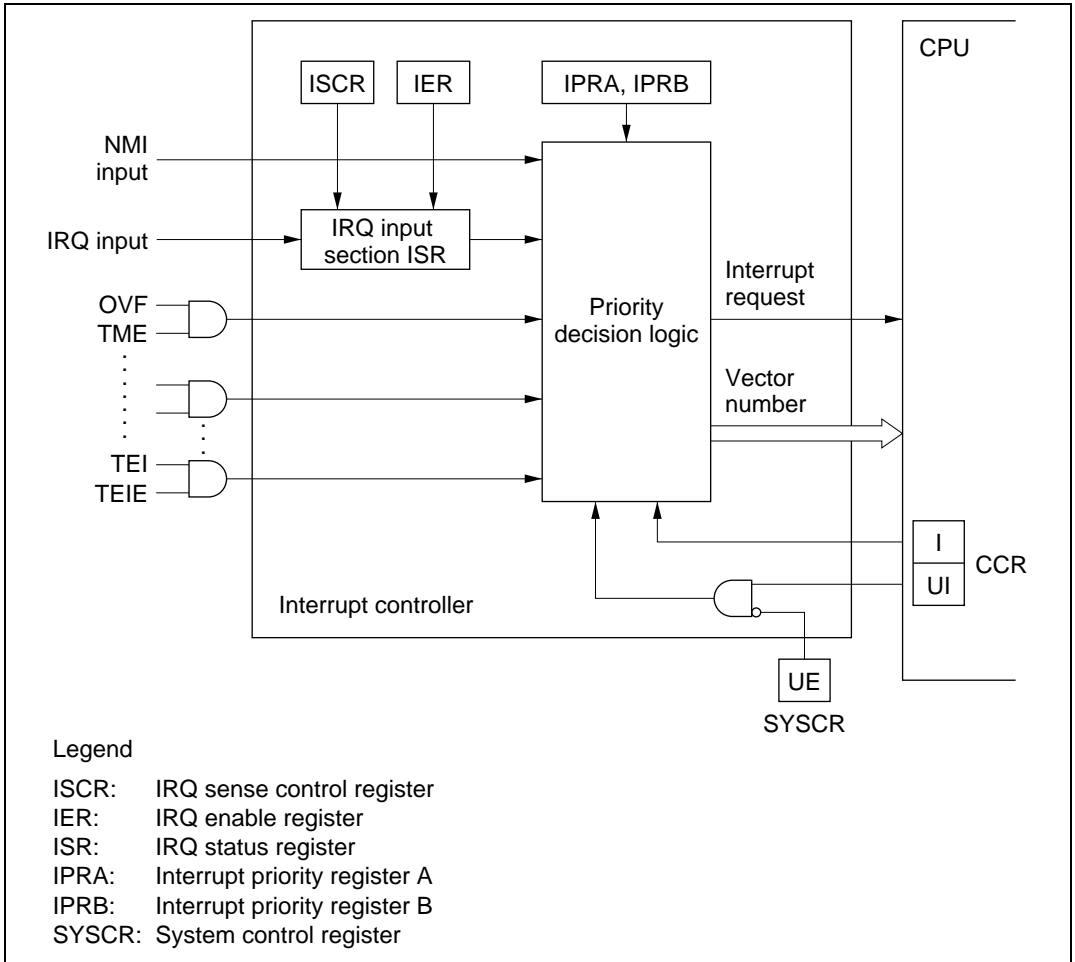

Figure 5.1 Interrupt Controller Block Diagram

5.1.3 Pin Configuration

Table 5.1 lists the interrupt pins.

Table 5.1 Interrupt Pins

Name	Abbreviation	I/O	Function
Nonmaskable interrupt	NMI	Input	Nonmaskable interrupt*, rising edge or falling edge selectable
External interrupt request 5 to 0	\overline{IRQ}_5 to \overline{IRQ}_0	Input	Maskable interrupts, falling edge or level sensing selectable

Note: *NMI input is sometimes disabled. For details see 18.9, NMI Input Disabling Conditions.

5.1.4 Register Configuration

Table 5.2 lists the registers of the interrupt controller.

Table 5.2 Interrupt Controller Registers

Address* ¹	Name	Abbreviation	R/W	Initial Value
H'EE012	System control register	SYSCR	R/W	H'09
H'EE014	IRQ sense control register	ISCR	R/W	H'00
H'EE015	IRQ enable register	IER	R/W	H'00
H'EE016	IRQ status register	ISR	R/(W)* ²	H'00
H'EE018	Interrupt priority register A	IPRA	R/W	H'00
H'EE019	Interrupt priority register B	IPRB	R/W	H'00

Notes: 1. Lower 20 bits of the address in advanced mode.
2. Only 0 can be written, to clear flags.

5.2 Register Descriptions

5.2.1 System Control Register (SYSCR)

SYSCR is an 8-bit readable/writable register that controls software standby mode, selects the action of the UI bit in CCR, selects the NMI edge, and enables or disables the on-chip RAM.

Only bits 3 and 2 are described here. For the other bits, see section 3.3, System Control Register (SYSCR).

SYSCR is initialized to H'09 by a reset and in hardware standby mode. It is not initialized in software standby mode.

Bit	7	6	5	4	3	2	1	0
	SSBY	STS2	STS1	STS0	UE	NMIEG	SSOE	RAME
Initial value	0	0	0	0	1	0	0	1
Read/Write	R/W	R/W	R/W	R/W	R/W	R/W	R/W	R/W

<p>Software standby</p>	<p>Standby timer select 2 to 0</p>	<p>User bit enable Selects whether to use the UI bit in CCR as a user bit or interrupt mask bit</p>	<p>NMI edge select Selects the NMI input edge</p>	<p>Software standby output port enable</p>	<p>RAM enable</p>
--------------------------------	---	--	--	---	--------------------------

Bit 3—User Bit Enable (UE): Selects whether to use the UI bit in CCR as a user bit or an interrupt mask bit.

Bit 3 UE	Description	
0	UI bit in CCR is used as interrupt mask bit	
1	UI bit in CCR is used as user bit	(Initial value)

Bit 2—NMI Edge Select (NMIEG): Selects the NMI input edge.

Bit 2 NMIEG	Description	
0	Interrupt is requested at falling edge of NMI input	(Initial value)
1	Interrupt is requested at rising edge of NMI input	

5.2.2 Interrupt Priority Registers A and B (IPRA, IPRB)

IPRA and IPRB are 8-bit readable/writable registers that control interrupt priority.

Interrupt Priority Register A (IPRA): IPRA is an 8-bit readable/writable register in which interrupt priority levels can be set.

Bit	7	6	5	4	3	2	1	0
	IPRA7	IPRA6	IPRA5	IPRA4	IPRA3	IPRA2	IPRA1	IPRA0
Initial value	0	0	0	0	0	0	0	0
Read/Write	R/W	R/W	R/W	R/W	R/W	R/W	R/W	R/W

Priority level A0
Selects the priority level of 16-bit timer channel 2 interrupt requests

Priority level A1
Selects the priority level of 16-bit timer channel 1 interrupt requests

Priority level A2
Selects the priority level of 16-bit timer channel 0 interrupt requests

Priority level A3
Selects the priority level of WDT, DRAM interface, and A/D converter interrupt requests

Priority level A4
Selects the priority level of IRQ₄ and IRQ₅ interrupt requests

Priority level A5
Selects the priority level of IRQ₂ and IRQ₃ interrupt requests

Priority level A6
Selects the priority level of IRQ₁ interrupt requests

Priority level A7
Selects the priority level of IRQ₀ interrupt requests

Priority level A0
Selects the priority level of 16-bit timer channel 2 interrupt requests

Priority level A1
Selects the priority level of 16-bit timer channel 1 interrupt requests

Priority level A2
Selects the priority level of 16-bit timer channel 0 interrupt requests

Priority level A3
Selects the priority level of WDT, DRAM interface, and A/D converter interrupt requests

Priority level A4
Selects the priority level of IRQ₄ and IRQ₅ interrupt requests

Priority level A5
Selects the priority level of IRQ₂ and IRQ₃ interrupt requests

Priority level A6
Selects the priority level of IRQ₁ interrupt requests

Priority level A7
Selects the priority level of IRQ₀ interrupt requests

IPRA is initialized to H'00 by a reset and in hardware standby mode.

Bit 7—Priority Level A7 (IPRA7): Selects the priority level of IRQ₀ interrupt requests.

Bit 7 IPRA7	Description
0	IRQ ₀ interrupt requests have priority level 0 (low priority) (Initial value)
1	IRQ ₀ interrupt requests have priority level 1 (high priority)

Bit 6—Priority Level A6 (IPRA6): Selects the priority level of IRQ₁ interrupt requests.

Bit 6 IPRA6	Description
0	IRQ ₁ interrupt requests have priority level 0 (low priority) (Initial value)
1	IRQ ₁ interrupt requests have priority level 1 (high priority)

Bit 5—Priority Level A5 (IPRA5): Selects the priority level of IRQ₂ and IRQ₃ interrupt requests.

Bit 5 IPRA5	Description
0	IRQ ₂ and IRQ ₃ interrupt requests have priority level 0 (low priority) (Initial value)
1	IRQ ₂ and IRQ ₃ interrupt requests have priority level 1 (high priority)

Bit 4—Priority Level A4 (IPRA4): Selects the priority level of IRQ₄ and IRQ₅ interrupt requests.

Bit 4 IPRA4	Description
0	IRQ ₄ and IRQ ₅ interrupt requests have priority level 0 (low priority) (Initial value)
1	IRQ ₄ and IRQ ₅ interrupt requests have priority level 1 (high priority)

Bit 3—Priority Level A3 (IPRA3): Selects the priority level of WDT, DRAM interface, and A/D converter interrupt requests.

Bit 3 IPRA3	Description
0	WDT, DRAM interface, and A/D converter interrupt requests have priority level 0 (low priority) (Initial value)
1	WDT, DRAM interface, and A/D converter interrupt requests have priority level 1 (high priority)

Bit 2—Priority Level A2 (IPRA2): Selects the priority level of 16-bit timer channel 0 interrupt requests.

Bit 2 IPRA2	Description
0	16-bit timer channel 0 interrupt requests have priority level 0 (low priority)(Initial value)
1	16-bit timer channel 0 interrupt requests have priority level 1 (high priority)

Bit 1—Priority Level A1 (IPRA1): Selects the priority level of 16-bit timer channel 1 interrupt requests.

Bit 1 IPRA1	Description
0	16-bit timer channel 1 interrupt requests have priority level 0 (low priority)(Initial value)
1	16-bit timer channel 1 interrupt requests have priority level 1 (high priority)

Bit 0—Priority Level A0 (IPRA0): Selects the priority level of 16-bit timer channel 2 interrupt requests.

Bit 0 IPRA0	Description
0	16-bit timer channel 2 interrupt requests have priority level 0 (low priority)(Initial value)
1	16-bit timer channel 2 interrupt requests have priority level 1 (high priority)

Interrupt Priority Register B (IPRB): IPRB is an 8-bit readable/writable register in which interrupt priority levels can be set.

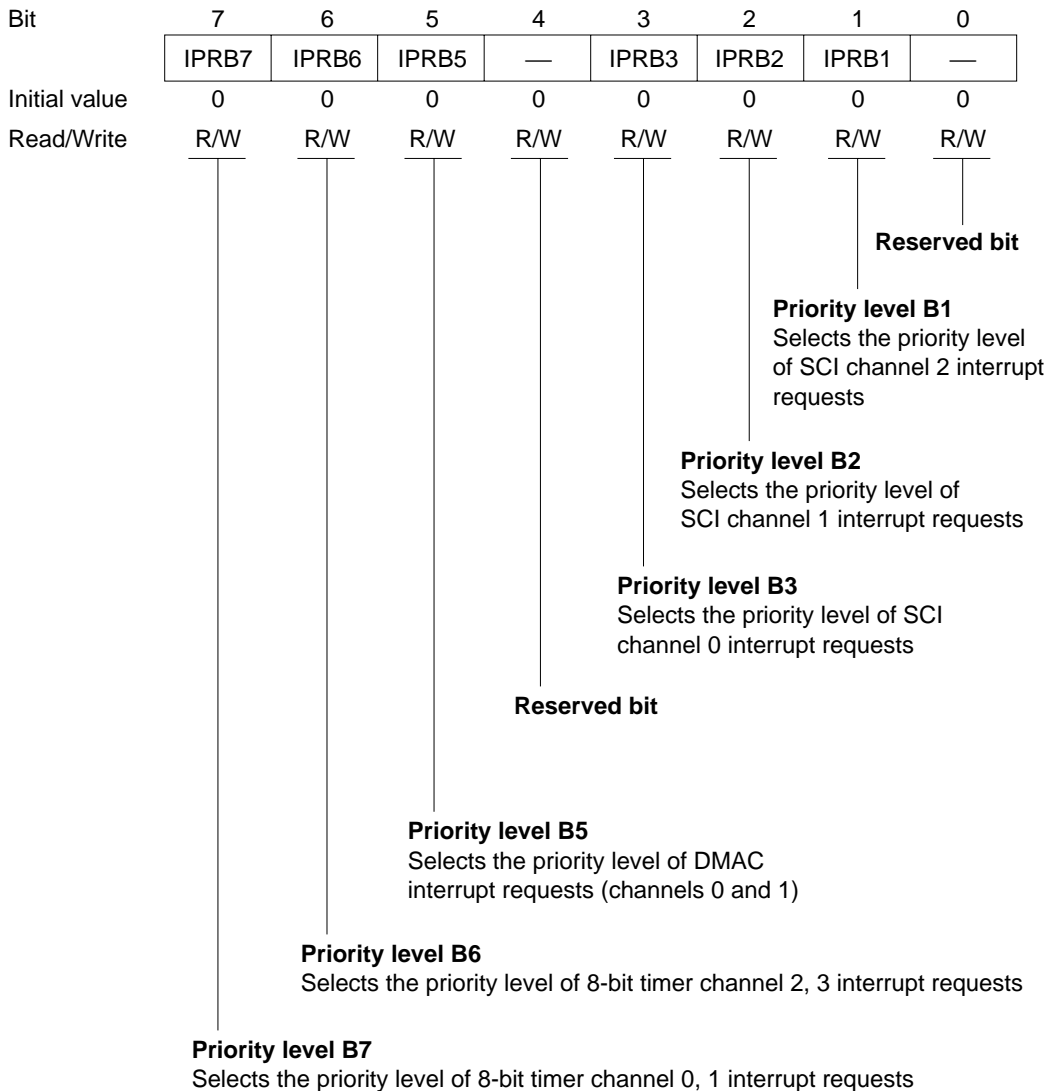

IPRB is initialized to H'00 by a reset and in hardware standby mode.

Bit 7—Priority Level B7 (IPRB7): Selects the priority level of 8-bit timer channel 0, 1 interrupt requests.

Bit 7 IPRB7	Description
0	8-bit timer channel 0, 1 interrupt requests have priority level 0 (low priority)(Initial value)
1	8-bit timer channel 0, 1 interrupt requests have priority level 1 (high priority)

Bit 6—Priority Level B6 (IPRB6): Selects the priority level of 8-bit timer channel 2, 3 interrupt requests.

Bit 6 IPRB6	Description
0	8-bit timer channel 2, 3 interrupt requests have priority level 0 (low priority)(Initial value)
1	8-bit timer channel 2, 3 interrupt requests have priority level 1 (high priority)

Bit 5—Priority Level B5 (IPRB5): Selects the priority level of DMAC interrupt requests (channels 0 and 1).

Bit 5 IPRB5	Description
0	DMAC interrupt requests (channels 0 and 1) have priority level 0 (low priority) (Initial value)
1	DMAC interrupt requests (channels 0 and 1) have priority level 1 (high priority)

Bit 4—Reserved: This bit can be written and read, but it does not affect interrupt priority.

Bit 3—Priority Level B3 (IPRB3): Selects the priority level of SCI channel 0 interrupt requests.

Bit 3 IPRB3	Description
0	SCI0 interrupt requests have priority level 0 (low priority) (Initial value)
1	SCI0 interrupt requests have priority level 1 (high priority)

Bit 2—Priority Level B2 (IPRB2): Selects the priority level of SCI channel 1 interrupt requests.

Bit 2

IPRB2	Description
0	SCI1 interrupt requests have priority level 0 (low priority) (Initial value)
1	SCI1 interrupt requests have priority level 1 (high priority)

Bit 1—Priority Level B1 (IPRB1): Selects the priority level of SCI channel 2 interrupt requests.

Bit 1

IPRB1	Description
0	SCI channel 2 interrupt requests have priority level 0 (low priority) (Initial value)
1	SCI channel 2 interrupt requests have priority level 1 (high priority)

Bit 0—Reserved: This bit can be written and read, but it does not affect interrupt priority.

5.2.3 IRQ Status Register (ISR)

ISR is an 8-bit readable/writable register that indicates the status of IRQ₀ to IRQ₅ interrupt requests.

Bit	7	6	5	4	3	2	1	0
	—	—	IRQ5F	IRQ4F	IRQ3F	IRQ2F	IRQ1F	IRQ0F
Initial value	0	0	0	0	0	0	0	0
Read/Write	—	—	R/(W)*	R/(W)*	R/(W)*	R/(W)*	R/(W)*	R/(W)*

Reserved bits
IRQ₅ to IRQ₀ flags
These bits indicate IRQ₅ to IRQ₀ interrupt request status

Note: * Only 0 can be written, to clear flags.

ISR is initialized to H'00 by a reset and in hardware standby mode.

Bits 7 and 6—Reserved: These bits can not be modified and are always read as 0.

Bits 5 to 0—IRQ₅ to IRQ₀ Flags (IRQ5F to IRQ0F): These bits indicate the status of IRQ₅ to IRQ₀ interrupt requests.

Bits 5 to 0

IRQ5F to IRQ0F Description

0	[Clearing conditions] 0 is written in IRQ _n F after reading the IRQ _n F flag when IRQ _n F = 1. IRQ _n SC = 0, $\overline{\text{IRQ}}_n$ input is high, and interrupt exception handling is carried out. IRQ _n SC = 1 and IRQ _n interrupt exception handling is carried out.	(Initial value)
1	[Setting conditions] IRQ _n SC = 0 and $\overline{\text{IRQ}}_n$ input is low. IRQ _n SC = 1 and $\overline{\text{IRQ}}_n$ input changes from high to low.	

Note: n = 5 to 0

5.2.4 IRQ Enable Register (IER)

IER is an 8-bit readable/writable register that enables or disables IRQ₅ to IRQ₀ interrupt requests.

Bit	7	6	5	4	3	2	1	0
	—	—	IRQ5E	IRQ4E	IRQ3E	IRQ2E	IRQ1E	IRQ0E
Initial value	0	0	0	0	0	0	0	0
Read/Write	R/W	R/W	R/W	R/W	R/W	R/W	R/W	R/W

Reserved bits
IRQ₅ to IRQ₀ enable
 These bits enable or disable IRQ₅ to IRQ₀ interrupts

IER is initialized to H'00 by a reset and in hardware standby mode.

Bits 7 and 6—Reserved: These bits can be written and read, but they do not enable or disable interrupts.

Bits 5 to 0—IRQ₅ to IRQ₀ Enable (IRQ5E to IRQ0E): These bits enable or disable IRQ₅ to IRQ₀ interrupts.

Bits 5 to 0

IRQ5E to IRQ0E Description

0	IRQ ₅ to IRQ ₀ interrupts are disabled	(Initial value)
1	IRQ ₅ to IRQ ₀ interrupts are enabled	

5.2.5 IRQ Sense Control Register (ISCR)

ISCR is an 8-bit readable/writable register that selects level sensing or falling-edge sensing of the inputs at pins $\overline{\text{IRQ}}_5$ to $\overline{\text{IRQ}}_0$.

Bit	7	6	5	4	3	2	1	0
	—	—	IRQ5SC	IRQ4SC	IRQ3SC	IRQ2SC	IRQ1SC	IRQ0SC
Initial value	0	0	0	0	0	0	0	0
Read/Write	R/W	R/W	R/W	R/W	R/W	R/W	R/W	R/W

Reserved bits

IRQ₅ to IRQ₀ sense control

These bits select level sensing or falling-edge sensing for IRQ₅ to IRQ₀ interrupts

ISCR is initialized to H'00 by a reset and in hardware standby mode.

Bits 7 and 6—Reserved: These bits can be written and read, but they do not select level or falling-edge sensing.

Bits 5 to 0—IRQ₅ to IRQ₀ Sense Control (IRQ5SC to IRQ0SC): These bits select whether interrupts IRQ₅ to IRQ₀ are requested by level sensing of pins $\overline{\text{IRQ}}_5$ to $\overline{\text{IRQ}}_0$, or by falling-edge sensing.

Bits 5 to 0

IRQ5SC to IRQ0SC Description

0	Interrupts are requested when $\overline{\text{IRQ}}_5$ to $\overline{\text{IRQ}}_0$ inputs are low (Initial value)
1	Interrupts are requested by falling-edge input at $\overline{\text{IRQ}}_5$ to $\overline{\text{IRQ}}_0$

5.3 Interrupt Sources

The interrupt sources include external interrupts (NMI, IRQ₀ to IRQ₅) and 36 internal interrupts.

5.3.1 External Interrupts

There are seven external interrupts: NMI, and IRQ₀ to IRQ₅. Of these, NMI, IRQ₀, IRQ₁, and IRQ₂ can be used to exit software standby mode.

NMI: NMI is the highest-priority interrupt and is always accepted, regardless of the states of the I and UI bits in CCR*. The NMIEG bit in SYSCR selects whether an interrupt is requested by the rising or falling edge of the input at the NMI pin. NMI interrupt exception handling has vector number 7.

Note: * NMI input is sometimes disabled. For details see section 18.9, NMI Input Disabling Conditions.

IRQ₀ to IRQ₅ Interrupts: These interrupts are requested by input signals at pins $\overline{\text{IRQ}}_0$ to $\overline{\text{IRQ}}_5$. The IRQ₀ to IRQ₅ interrupts have the following features.

- ISCR settings can select whether an interrupt is requested by the low level of the input at pins $\overline{\text{IRQ}}_0$ to $\overline{\text{IRQ}}_5$, or by the falling edge.
- IER settings can enable or disable the IRQ₀ to IRQ₅ interrupts. Interrupt priority levels can be assigned by four bits in IPRA (IPRA7 to IPRA4).
- The status of IRQ₀ to IRQ₅ interrupt requests is indicated in ISR. The ISR flags can be cleared to 0 by software.

Figure 5.2 shows a block diagram of interrupts IRQ₀ to IRQ₅.

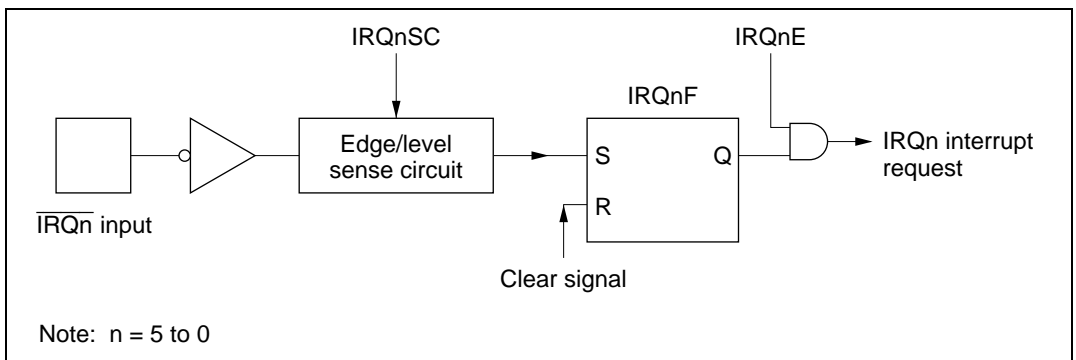

Figure 5.2 Block Diagram of Interrupts IRQ₀ to IRQ₅

Figure 5.3 shows the timing of the setting of the interrupt flags (IRQnF).

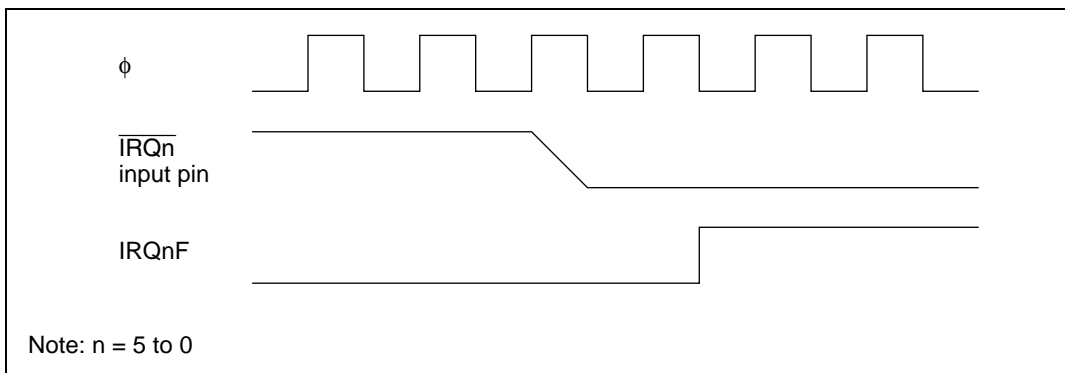

Figure 5.3 Timing of Setting of IRQnF

Interrupts IRQ₀ to IRQ₅ have vector numbers 12 to 17. These interrupts are detected regardless of whether the corresponding pin is set for input or output. When using a pin for external interrupt input, clear its DDR bit to 0 and do not use the pin for chip select output, refresh output, SCI input/output, or A/D external trigger input.

5.3.2 Internal Interrupts

Thirty-Six internal interrupts are requested from the on-chip supporting modules.

- Each on-chip supporting module has status flags for indicating interrupt status, and enable bits for enabling or disabling interrupts.
- Interrupt priority levels can be assigned in IPRA and IPRB.
- 16-bit timer, SCI, and A/D converter interrupt requests can activate the DMAC, in which case no interrupt request is sent to the interrupt controller, and the I and UI bits are disregarded.

5.3.3 Interrupt Vector Table

Table 5.3 lists the interrupt sources, their vector addresses, and their default priority order. In the default priority order, smaller vector numbers have higher priority. The priority of interrupts other than NMI can be changed in IPRA and IPRB. The priority order after a reset is the default order shown in table 5.3.

Table 5.3 Interrupt Sources, Vector Addresses, and Priority

Interrupt Source	Origin	Vector Number	Vector Address*		IPR	Priority	
			Advanced Mode	Normal Mode			
NMI	External pins	7	H'001C to H'001F	H'000E to H'000F	—	High	
IRQ ₀		12	H'0030 to H'0033	H'0018 to H'0019	IPRA7	↑	
IRQ ₁		13	H'0034 to H'0037	H'001A to H'001B	IPRA6		
IRQ ₂		14	H'0038 to H'003B	H'001C to H'001D	IPRA5		
IRQ ₃		15	H'003C to H'003F	H'001E to H'001F			
IRQ ₄		16	H'0040 to H'0043	H'0020 to H'0021	IPRA4		
IRQ ₅	17	H'0044 to H'0047	H'0022 to H'0023				
Reserved	—	18	H'0048 to H'004B	H'0024 to H'0025			
		19	H'004C to H'004F	H'0026 to H'0027			
WOVI (interval timer)	Watchdog timer	20	H'0050 to H'0053	H'0028 to H'0029	IPRA3		↓
CMI (compare match)	DRAM interface	21	H'0054 to H'0057	H'002A to H'002B			
Reserved	—	22	H'0058 to H'005B	H'002C to H'002D			
ADI (A/D end)	A/D	23	H'005C to H'005F	H'002E to H'002F			
IMIA0 (compare match/ input capture A0)	16-bit timer channel 0	24	H'0060 to H'0063	H'0030 to H'0031	IPRA2		
IMIB0 (compare match/ input capture B0)		25	H'0064 to H'0067	H'0032 to H'0033			
OVI0 (overflow 0)		26	H'0068 to H'006B	H'0034 to H'0035			
Reserved	—	27	H'006C to H'006F	H'0036 to H'0037			
IMIA1 (compare match/ inputcapture A1)	16-bit timer channel 1	28	H'0070 to H'0073	H'0038 to H'0039	IPRA1		
IMIB1 (compare match/ input capture B1)		29	H'0074 to H'0077	H'003A to H'003B			
OVI1 (overflow 1)		30	H'0078 to H'007B	H'003C to H'003D			
Reserved	—	31	H'007C to H'007F	H'003E to H'003F		Low	

Note: * Lower 16 bits of the address.

Interrupt Source	Origin	Vector Number	Vector Address*		IPR	Priority
			Advanced Mode	Normal Mode		
IMIA2 (compare match/ input capture A2)	16-bit timer channel 2	32	H'0080 to H'0083	H'0040 to H'0041	IPRA0	High ↑
IMIB2 (compare match/ input capture B2)		33	H'0084 to H'0087	H'0042 to H'0043		
OVI2 (overflow 2)		34	H'0088 to H'008B	H'0044 to H'0045		
Reserved	—	35	H'008C to H'008F	H'0046 to H'0047		
CMIA0 (compare match A0)	8-bit timer channel 0/1	36	H'0090 to H'0093	H'0048 to H'0049	IPRB7	↓ Low
CMIB0 (compare match B0)		37	H'0094 to H'0097	H'004A to H'004B		
CMIA1/CMIB1 (compare match A1/B1)		38	H'0098 to H'009B	H'004C to H'004D		
TOVI0/TOV11 (overflow 0/1)		39	H'009C to H'009F	H'004E to H'004F		
CMIA2 (compare match A2)	8-bit timer channel 2/3	40	H'00A0 to H'00A3	H'0050 to H'0051	IPRB6	
CMIB2 (compare match B2)		41	H'00A4 to H'00A7	H'0052 to H'0053		
CMIA3/CMIB3 (compare match A3/B3)		42	H'00A8 to H'00AB	H'0054 to H'0055		
TOVI2/TOVI3 (overflow 2/3)		43	H'00AC to H'00AF	H'0056 to H'0057		
DEND0A	DMAC	44	H'00B0 to H'00B3	H'0058 to H'0059	IPRB5	
DEND0B		45	H'00B4 to H'00B7	H'005A to H'005B		
DEND1A		46	H'00B8 to H'00BB	H'005C to H'005D		
DEND1B		47	H'00BC to H'00BF	H'005E to H'005F		
Reserved	—	48	H'00C0 to H'00C3	H'0060 to H'0061	—	
		49	H'00C4 to H'00C7	H'0062 to H'0063		
		50	H'00C8 to H'00CB	H'0064 to H'0065		
		51	H'00CC to H'00CF	H'0066 to H'0067		

Note: * Lower 16 bits of the address.

Interrupt Source	Origin	Vector Number	Vector Address*		IPR	Priority
			Advanced Mode	Normal Mode		
ERI0 (receive error 0)	SCI channel 0	52	H'00D0 to H'00D3	H'0068 to H'0069	IPRB3	High ↑
RXI0 (receive data full 0)		53	H'00D4 to H'00D7	H'006A to H'006B		
TXI0 (transmit data empty 0)		54	H'00D8 to H'00DB	H'006C to H'006D		
TEI0 (transmit end 0)		55	H'00DC to H'00DF	H'006E to H'006F		
ERI1 (receive error 1)	SCI channel 1	56	H'00E0 to H'00E3	H'0070 to H'0071	IPRB2	↓
RXI1 (receive data full 1)		57	H'00E4 to H'00E7	H'0072 to H'0073		
TXI1 (transmit data empty 1)		58	H'00E8 to H'00EB	H'0074 to H'0075		
TEI1 (transmit end 1)		59	H'00EC to H'00EF	H'0076 to H'0077		
ERI2 (receive error 2)	SCI channel 2	60	H'00F0 to H'00F3	H'0078 to H'0079	IPRB1	Low ↓
RXI2 (receive data full 2)		61	H'00F4 to H'00F7	H'007A to H'007B		
TXI2 (transmit data empty 2)		62	H'00F8 to H'00FB	H'007C to H'007D		
TEI2 (transmit end 2)		63	H'00FC to H'00FF	H'007E to H'007F		

Note: * Lower 16 bits of the address.

5.4 Interrupt Operation

5.4.1 Interrupt Handling Process

The H8/3068F handles interrupts differently depending on the setting of the UE bit. When UE = 1, interrupts are controlled by the I bit. When UE = 0, interrupts are controlled by the I and UI bits. Table 5.4 indicates how interrupts are handled for all setting combinations of the UE, I, and UI bits.

NMI interrupts are always accepted except in the reset and hardware standby states*. IRQ interrupts and interrupts from the on-chip supporting modules have their own enable bits. Interrupt requests are ignored when the enable bits are cleared to 0.

Note: * NMI input is sometimes disabled. For details see section 18.9, NMI Input Disabling Conditions.

Table 5.4 UE, I, and UI Bit Settings and Interrupt Handling

SYSCR	CCR		Description
	I	UI	
1	0	—	All interrupts are accepted. Interrupts with priority level 1 have higher priority.
	1	—	No interrupts are accepted except NMI.
0	0	—	All interrupts are accepted. Interrupts with priority level 1 have higher priority.
	1	0	NMI and interrupts with priority level 1 are accepted.
	1	1	No interrupts are accepted except NMI.

UE = 1: Interrupts IRQ₀ to IRQ₅ and interrupts from the on-chip supporting modules can all be masked by the I bit in the CPU's CCR. Interrupts are masked when the I bit is set to 1, and unmasked when the I bit is cleared to 0. Interrupts with priority level 1 have higher priority. Figure 5.4 is a flowchart showing how interrupts are accepted when UE = 1.

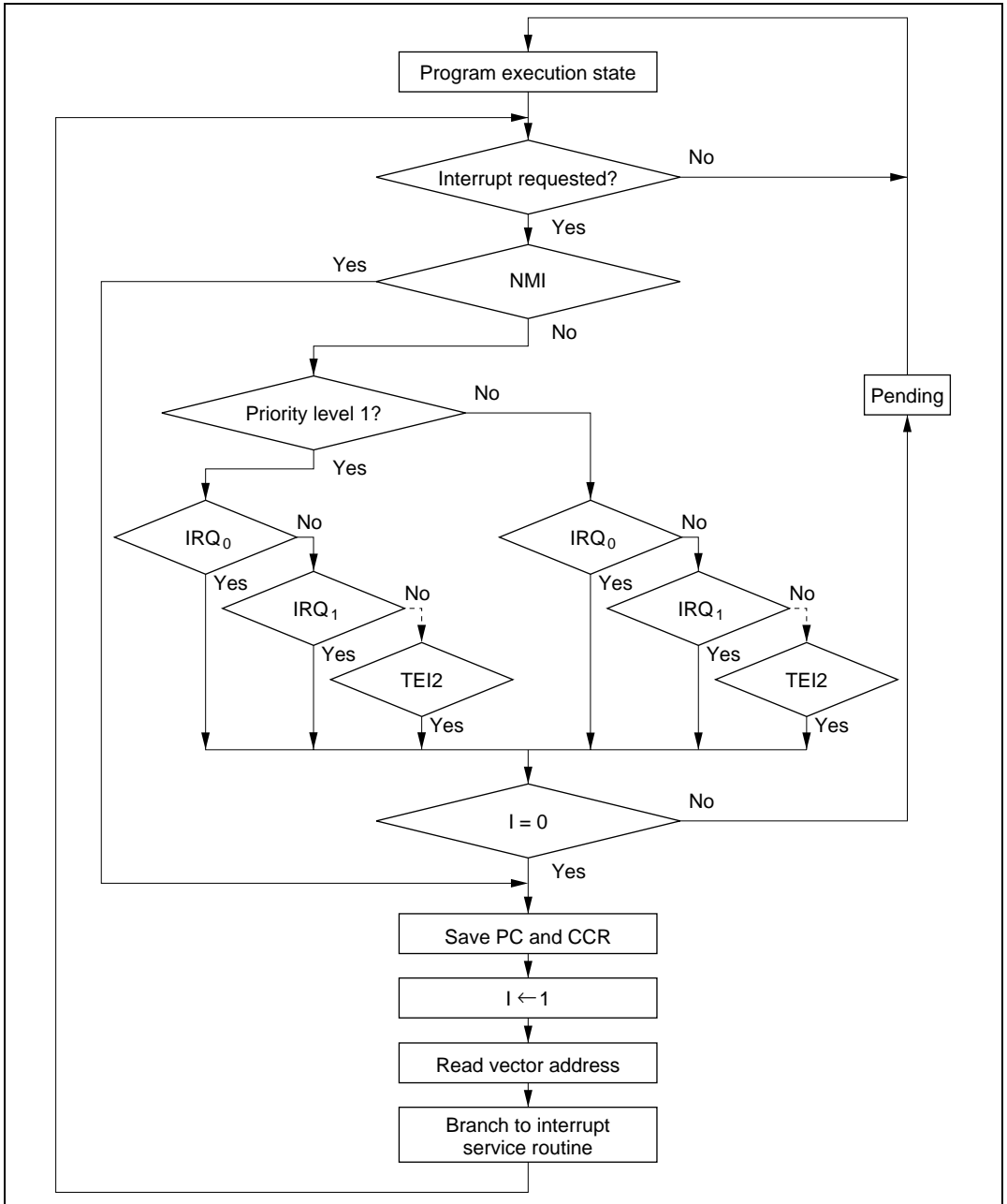

Figure 5.4 Process Up to Interrupt Acceptance when UE = 1

- If an interrupt condition occurs and the corresponding interrupt enable bit is set to 1, an interrupt request is sent to the interrupt controller.
- When the interrupt controller receives one or more interrupt requests, it selects the highest-priority request, following the IPR interrupt priority settings, and holds other requests pending. If two or more interrupts with the same IPR setting are requested simultaneously, the interrupt controller follows the priority order shown in table 5.3.
- The interrupt controller checks the I bit. If the I bit is cleared to 0, the selected interrupt request is accepted. If the I bit is set to 1, only NMI is accepted; other interrupt requests are held pending.
- When an interrupt request is accepted, interrupt exception handling starts after execution of the current instruction has been completed.
- In interrupt exception handling, PC and CCR are saved to the stack area. The PC value that is saved indicates the address of the first instruction that will be executed after the return from the interrupt service routine.
- Next the I bit is set to 1 in CCR, masking all interrupts except NMI.
- The vector address of the accepted interrupt is generated, and the interrupt service routine starts executing from the address indicated by the contents of the vector address.

UE = 0: The I and UI bits in the CPU's CCR and the IPR bits enable three-level masking of IRQ₀ to IRQ₅ interrupts and interrupts from the on-chip supporting modules.

- Interrupt requests with priority level 0 are masked when the I bit is set to 1, and are unmasked when the I bit is cleared to 0.
- Interrupt requests with priority level 1 are masked when the I and UI bits are both set to 1, and are unmasked when either the I bit or the UI bit is cleared to 0.

For example, if the interrupt enable bits of all interrupt requests are set to 1, IPRA is set to H'20, and IPRB is set to H'00 (giving IRQ₂ and IRQ₃ interrupt requests priority over other interrupts), interrupts are masked as follows:

- a. If I = 0, all interrupts are unmasked (priority order: NMI > IRQ₂ > IRQ₃ > IRQ₀ ...).
- b. If I = 1 and UI = 0, only NMI, IRQ₂, and IRQ₃ are unmasked.
- c. If I = 1 and UI = 1, all interrupts are masked except NMI.

Figure 5.5 shows the transitions among the above states.

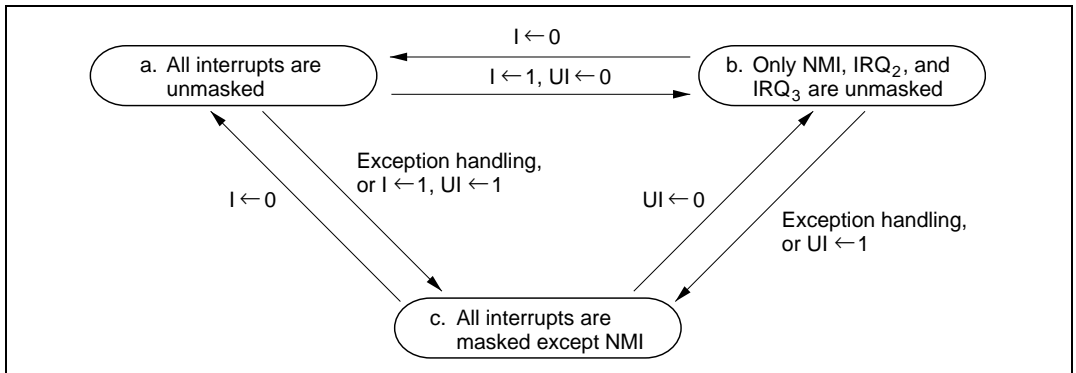

Figure 5.5 Interrupt Masking State Transitions (Example)

Figure 5.6 is a flowchart showing how interrupts are accepted when UE = 0.

- If an interrupt condition occurs and the corresponding interrupt enable bit is set to 1, an interrupt request is sent to the interrupt controller.
- When the interrupt controller receives one or more interrupt requests, it selects the highest-priority request, following the IPR interrupt priority settings, and holds other requests pending. If two or more interrupts with the same IPR setting are requested simultaneously, the interrupt controller follows the priority order shown in table 5.3.
- The interrupt controller checks the I bit. If the I bit is cleared to 0, the selected interrupt request is accepted regardless of its IPR setting, and regardless of the UI bit. If the I bit is set to 1 and the UI bit is cleared to 0, only NMI and interrupts with priority level 1 are accepted; interrupt requests with priority level 0 are held pending. If the I bit and UI bit are both set to 1, only NMI is accepted; all other interrupt requests are held pending.
- When an interrupt request is accepted, interrupt exception handling starts after execution of the current instruction has been completed.
- In interrupt exception handling, PC and CCR are saved to the stack area. The PC value that is saved indicates the address of the first instruction that will be executed after the return from the interrupt service routine.
- The I and UI bits are set to 1 in CCR, masking all interrupts except NMI.
- The vector address of the accepted interrupt is generated, and the interrupt service routine starts executing from the address indicated by the contents of the vector address.

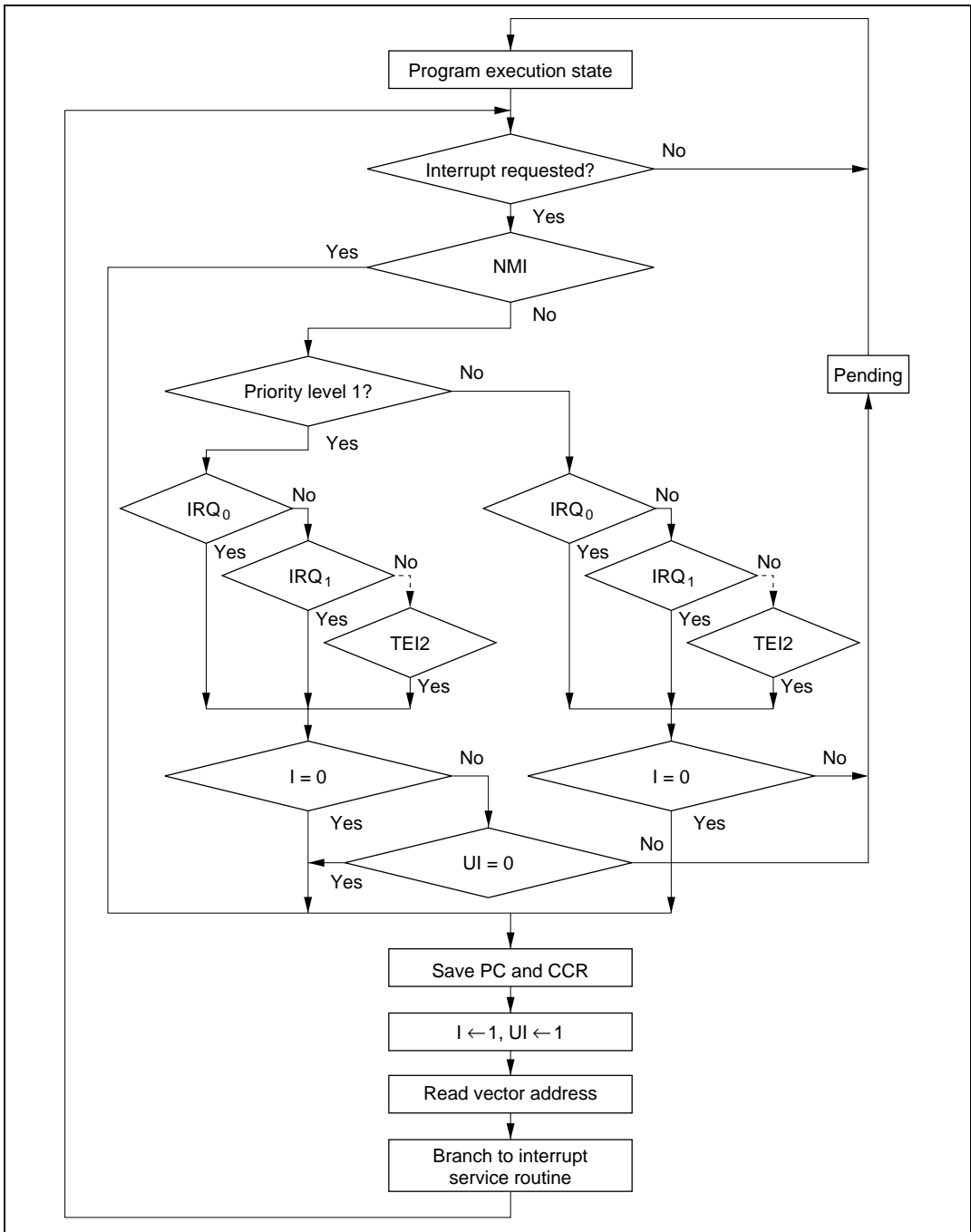

Figure 5.6 Process Up to Interrupt Acceptance when UE = 0

5.4.2 Interrupt Sequence

Figure 5.7 shows the interrupt sequence in mode 2 when the program code and stack are in an external memory area accessed in two states via a 16-bit bus.

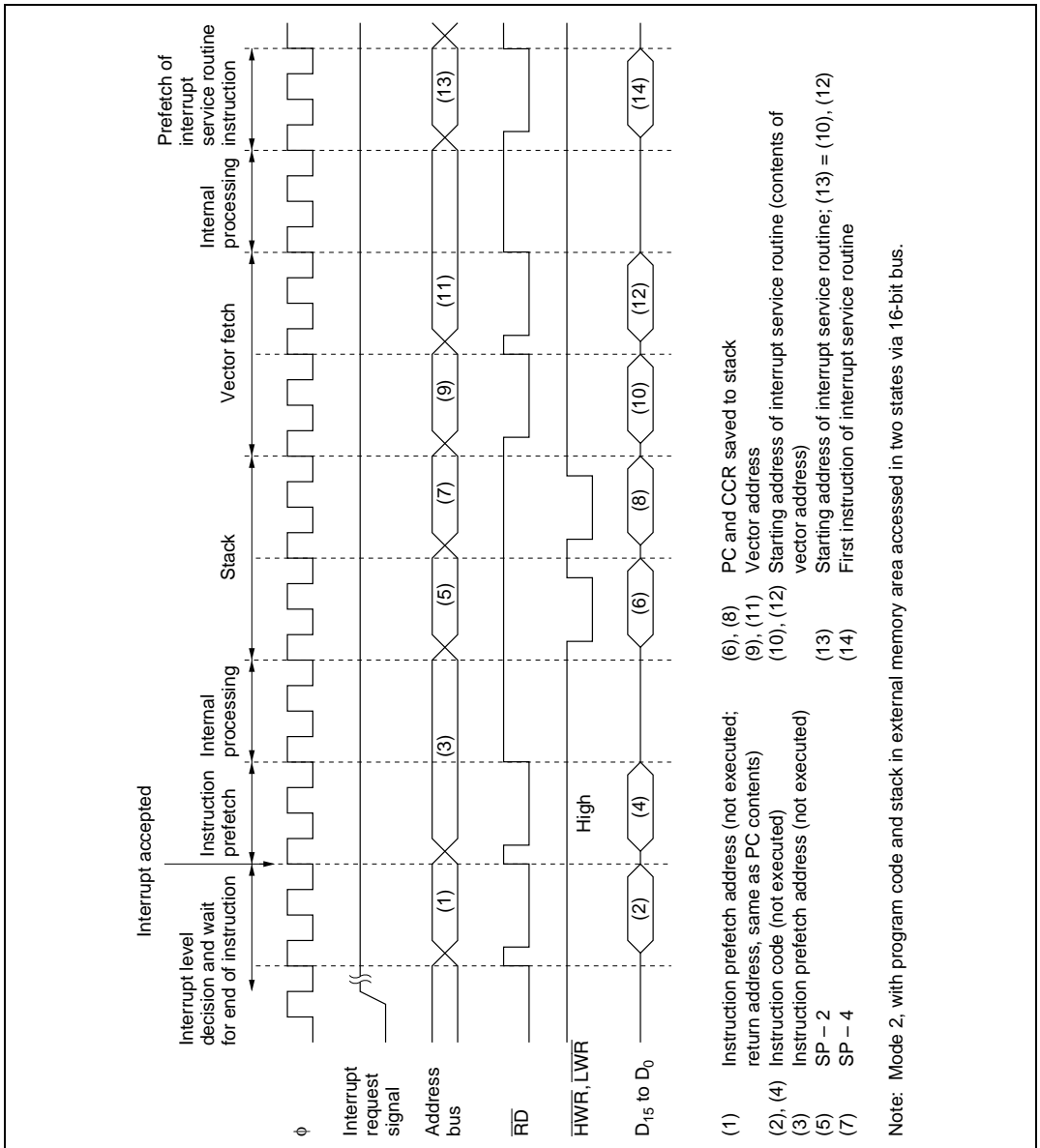

Figure 5.7 Interrupt Sequence

5.4.3 Interrupt Response Time

Table 5.5 indicates the interrupt response time from the occurrence of an interrupt request until the first instruction of the interrupt service routine is executed.

Table 5.5 Interrupt Response Time

No.	Item	On-Chip Memory	External Memory			
			8-Bit Bus		16-Bit Bus	
			2 States	3 States	2 States	3 States
1	Interrupt priority decision	2* ¹	2* ¹	2* ¹	2* ¹	2* ¹
2	Maximum number of states until end of current instruction	1 to 23* ⁵	1 to 27* ⁵	1 to 41* ^{4,*6}	1 to 23* ⁵	1 to 25* ^{4,*5}
3	Saving PC and CCR to stack	4	8	12* ⁴	4	6* ⁴
4	Vector fetch	4	8	12* ⁴	4	6* ⁴
5	Instruction prefetch* ²	4	8	12* ⁴	4	6* ⁴
6	Internal processing* ³	4	4	4	4	4
Total		19 to 41	31 to 57	43 to 83	19 to 41	25 to 49

Notes: 1. 1 state for internal interrupts.

2. Prefetch after the interrupt is accepted and prefetch of the first instruction in the interrupt service routine.

3. Internal processing after the interrupt is accepted and internal processing after vector fetch.

4. The number of states increases if wait states are inserted in external memory access.

5. Example for DIVXS.W Rs,ERd and MULXS.W Rs,ERd

6. Example for MOV.L @(d:24,ERs),ERd and MOV.L ERs,@(d:24,ERd)

5.5 Usage Notes

5.5.1 Contention between Interrupt and Interrupt-Disabling Instruction

When an instruction clears an interrupt enable bit to 0 to disable the interrupt, the interrupt is not disabled until after execution of the instruction is completed. If an interrupt occurs while a BCLR, MOV, or other instruction is being executed to clear its interrupt enable bit to 0, at the instant when execution of the instruction ends the interrupt is still enabled, so its interrupt exception handling is carried out. If a higher-priority interrupt is also requested, however, interrupt exception handling for the higher-priority interrupt is carried out, and the lower-priority interrupt is ignored. This also applies to the clearing of an interrupt flag to 0.

Figure 5.8 shows an example in which an IMIEA bit is cleared to 0 in the 16-bit timer's TISRA register.

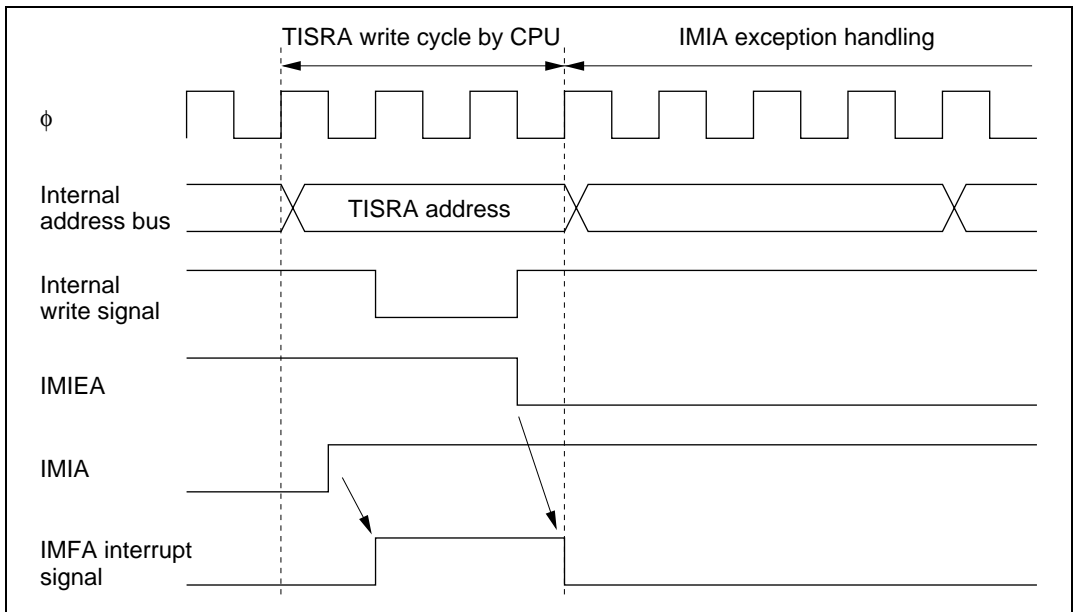

Figure 5.8 Contention between Interrupt and Interrupt-Disabling Instruction

This type of contention will not occur if the interrupt is masked when the interrupt enable bit or flag is cleared to 0.

5.5.2 Instructions that Inhibit Interrupts

The LDC, ANDC, ORC, and XORC instructions inhibit interrupts. When an interrupt occurs, after determining the interrupt priority, the interrupt controller requests a CPU interrupt. If the CPU is currently executing one of these interrupt-inhibiting instructions, however, when the instruction is completed the CPU always continues by executing the next instruction.

5.5.3 Interrupts during EEPMOV Instruction Execution

The EEPMOV.B and EEPMOV.W instructions differ in their reaction to interrupt requests.

When the EEPMOV.B instruction is executing a transfer, no interrupts are accepted until the transfer is completed, not even NMI.

When the EEPMOV.W instruction is executing a transfer, interrupt requests other than NMI are not accepted until the transfer is completed. If NMI is requested, NMI exception handling starts at a transfer cycle boundary. The PC value saved on the stack is the address of the next instruction. Programs should be coded as follows to allow for NMI interrupts during EEPMOV.W execution:

```
L1: EEPMOV.W  
    MOV.W R4,R4  
    BNE L1
```

Section 6 Bus Controller

6.1 Overview

The H8/3068F has an on-chip bus controller (BSC) that manages the external address space divided into eight areas. The bus specifications, such as bus width and number of access states, can be set independently for each area, enabling multiple memories to be connected easily.

The bus controller also has a bus arbitration function that controls the operation of the internal bus masters—the CPU, DMA controller (DMAC), and DRAM interface and can release the bus to an external device.

6.1.1 Features

The features of the bus controller are listed below.

- Manages external address space in area units
 - Manages the external space as eight areas (0 to 7) of 128 kbytes in 1M-byte modes, or 2 Mbytes in 16-Mbyte modes
 - Bus specifications can be set independently for each area
 - DRAM/burst ROM interfaces can be set
- Basic bus interface
 - Chip select (\overline{CS}_0 to \overline{CS}_7) can be output for areas 0 to 7
 - 8-bit access or 16-bit access can be selected for each area
 - Two-state access or three-state access can be selected for each area
 - Program wait states can be inserted for each area
 - Pin wait insertion capability is provided
- DRAM interface
 - DRAM interface can be set for areas 2 to 5
 - Row address/column address multiplexed output (8/9/10 bits)
 - 2-CAS byte access mode
 - Burst operation (fast page mode)
 - T_P cycle insertion to secure RAS precharging time
 - Choice of CAS-before-RAS refreshing or self-refreshing
- Burst ROM interface
 - Burst ROM interface can be set for area 0
 - Selection of two- or three-state burst access

- Idle cycle insertion
 - An idle cycle can be inserted in case of an external read cycle between different areas
 - An idle cycle can be inserted when an external read cycle is immediately followed by an external write cycle
- Bus arbitration function
 - A built-in bus arbiter grants the bus right to the CPU, DMAC, DRAM interface, or an external bus master
- Other features
 - Refresh counter (refresh timer) can be used as interval timer
 - Choice of two address update modes

6.1.2 Block Diagram

Figure 6.1 shows a block diagram of the bus controller.

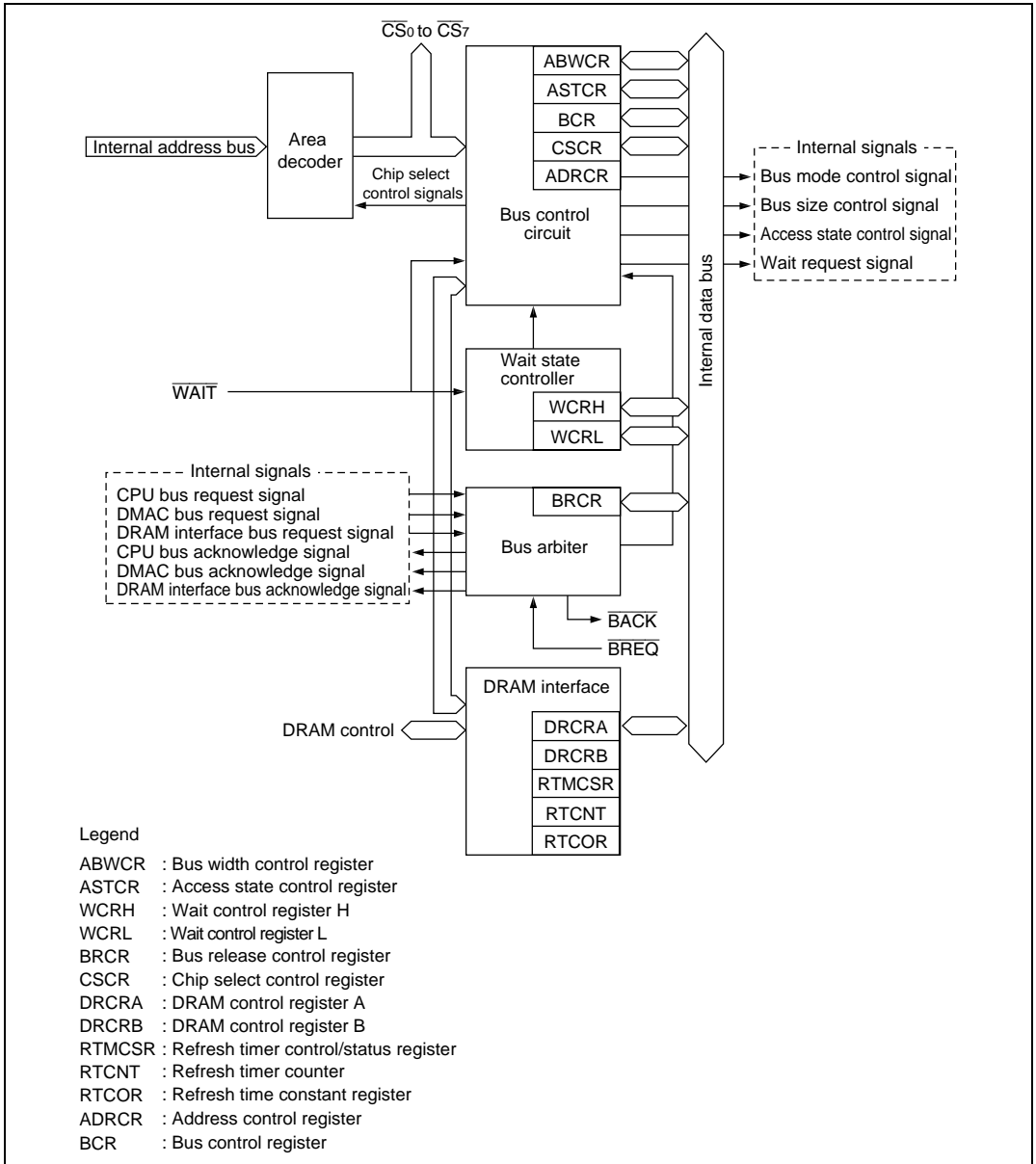

Figure 6.1 Block Diagram of Bus Controller

6.1.3 Pin Configuration

Table 6.1 summarizes the input/output pins of the bus controller.

Table 6.1 Bus Controller Pins

Name	Abbreviation	I/O	Function
Chip select 0 to 7	\overline{CS}_0 to \overline{CS}_7	Output	Strobe signals selecting areas 0 to 7
Address strobe	\overline{AS}	Output	Strobe signal indicating valid address output on the address bus
Read	\overline{RD}	Output	Strobe signal indicating reading from the external address space
High write	\overline{HWR}	Output	Strobe signal indicating writing to the external address space, with valid data on the upper data bus (D ₁₅ to D ₈)
Low write	\overline{LWR}	Output	Strobe signal indicating writing to the external address space, with valid data on the lower data bus (D ₇ to D ₀)
Wait	\overline{WAIT}	Input	Wait request signal for access to external three-state access areas
Bus request	\overline{BREQ}	Input	Request signal for releasing the bus to an external device
Bus acknowledge	\overline{BACK}	Output	Acknowledge signal indicating release of the bus to an external device

6.1.4 Register Configuration

Table 6.2 summarizes the bus controller's registers.

Table 6.2 Bus Controller Registers

Address* ¹	Name	Abbreviation	R/W	Initial Value
H'EE020	Bus width control register	ABWCR	R/W	H'FF* ²
H'EE021	Access state control register	ASTCR	R/W	H'FF
H'EE022	Wait control register H	WCRH	R/W	H'FF
H'EE023	Wait control register L	WCRL	R/W	H'FF
H'EE013	Bus release control register	BRCR	R/W	H'FE* ³
H'EE01F	Chip select control register	CSCR	R/W	H'0F
H'EE01E	Address control register	ADRCR	R/W	H'FF
H'EE024	Bus control register	BCR	R/W	H'C6
H'EE026	DRAM control register A	DRCRA	R/W	H'10
H'EE027	DRAM control register B	DRCRB	R/W	H'08
H'EE028	Refresh timer control/status register	RTMCSR	R(W)* ⁴	H'07
H'EE029	Refresh timer counter	RTCNT	R/W	H'00
H'EE02A	Refresh time constant register	RTCOR	R/W	H'FF

Notes: 1. Lower 20 bits of the address in advanced mode.

2. In modes 2 and 4, the initial value is H'00.

3. In modes 3 and 4, the initial value is H'EE.

4. For Bit 7, only 0 can be written to clear the flag.

6.2 Register Descriptions

6.2.1 Bus Width Control Register (ABWCR)

ABWCR is an 8-bit readable/writable register that selects 8-bit or 16-bit access for each area.

Bit		7	6	5	4	3	2	1	0
		ABW7	ABW6	ABW5	ABW4	ABW3	ABW2	ABW1	ABW0
Modes 1, 3, 5, 6, and 7	Initial value	1	1	1	1	1	1	1	1
	Read/Write	R/W	R/W	R/W	R/W	R/W	R/W	R/W	R/W
Modes 2 and 4	Initial value	0	0	0	0	0	0	0	0
	Read/Write	R/W	R/W	R/W	R/W	R/W	R/W	R/W	R/W

When ABWCR contains H'FF (selecting 8-bit access for all areas), the chip operates in 8-bit bus mode: the upper data bus (D_{15} to D_8) is valid, and port 4 is an input/output port. When at least one bit is cleared to 0 in ABWCR, the chip operates in 16-bit bus mode with a 16-bit data bus (D_{15} to D_0). In modes 1, 3, 5, 6, and 7, ABWCR is initialized to H'FF by a reset and in hardware standby mode. In modes 2 and 4, ABWCR is initialized to H'00 by a reset and in hardware standby mode. It is not initialized in software standby mode.

Bits 7 to 0—Area 7 to 0 Bus Width Control (ABW7 to ABW0): These bits select 8-bit access or 16-bit access for the corresponding areas.

Bits 7 to 0

ABW7 to ABW0 Description

ABW7 to ABW0	Description
0	Areas 7 to 0 are 16-bit access areas
1	Areas 7 to 0 are 8-bit access areas

ABWCR specifies the data bus width of external memory areas. The data bus width of on-chip memory and registers is fixed, and does not depend on ABWCR settings. These settings are therefore meaningless in the single-chip modes (modes 6 and 7).

6.2.2 Access State Control Register (ASTCR)

ASTCR is an 8-bit readable/writable register that selects whether each area is accessed in two states or three states.

Bit	7	6	5	4	3	2	1	0
	AST7	AST6	AST5	AST4	AST3	AST2	AST1	AST0
Initial value	1	1	1	1	1	1	1	1
Read/Write	R/W	R/W	R/W	R/W	R/W	R/W	R/W	R/W

Bits selecting number of states for access to each area

ASTCR is initialized to H'FF by a reset and in hardware standby mode. It is not initialized in software standby mode.

Bits 7 to 0—Area 7 to 0 Access State Control (AST7 to AST0): These bits select whether the corresponding area is accessed in two or three states.

Bits 7 to 0

AST7 to AST0	Description
0	Areas 7 to 0 are accessed in two states
1	Areas 7 to 0 are accessed in three states (Initial value)

ASTCR specifies the number of states in which external areas are accessed. On-chip memory and registers are accessed in a fixed number of states that does not depend on ASTCR settings. These settings are therefore meaningless in the single-chip modes (modes 6 and 7).

When the corresponding area is designated as DRAM space by bits DRAS2 to DRAS0 in DRAM control register A (DRCRA), the number of access states does not depend on the AST bit setting. When an AST bit is cleared to 0, programmable wait insertion is not performed.

6.2.3 Wait Control Registers H and L (WCRH, WCRL)

WCRH and WCRL are 8-bit readable/writable registers that select the number of program wait states for each area.

On-chip memory and registers are accessed in a fixed number of states that does not depend on WCRH/WCRL settings.

WCRH and WCRL are initialized to H'FF by a reset and in hardware standby mode. They are not initialized in software standby mode.

WCRH

Bit	7	6	5	4	3	2	1	0
	W71	W70	W61	W60	W51	W50	W41	W40
Initial value	1	1	1	1	1	1	1	1
Read/Write	R/W	R/W	R/W	R/W	R/W	R/W	R/W	R/W

Bits 7 and 6—Area 7 Wait Control 1 and 0 (W71, W70): These bits select the number of program wait states when area 7 in external space is accessed while the AST7 bit in ASTCR is set to 1.

Bit 7 W71	Bit 6 W70	Description
0	0	Program wait not inserted when external space area 7 is accessed
	1	1 program wait state inserted when external space area 7 is accessed
1	0	2 program wait states inserted when external space area 7 is accessed
	1	3 program wait states inserted when external space area 7 is accessed (Initial value)

Bits 5 and 4—Area 6 Wait Control 1 and 0 (W61, W60): These bits select the number of program wait states when area 6 in external space is accessed while the AST6 bit in ASTCR is set to 1.

Bit 5 W61	Bit 4 W60	Description
0	0	Program wait not inserted when external space area 6 is accessed
	1	1 program wait state inserted when external space area 6 is accessed
1	0	2 program wait states inserted when external space area 6 is accessed
	1	3 program wait states inserted when external space area 6 is accessed (Initial value)

Bits 3 and 2—Area 5 Wait Control 1 and 0 (W51, W50): These bits select the number of program wait states when area 5 in external space is accessed while the AST5 bit in ASTCR is set to 1.

Bit 3 W51	Bit 2 W50	Description
0	0	Program wait not inserted when external space area 5 is accessed
	1	1 program wait state inserted when external space area 5 is accessed
1	0	2 program wait states inserted when external space area 5 is accessed
	1	3 program wait states inserted when external space area 5 is accessed (Initial value)

Bits 1 and 0—Area 4 Wait Control 1 and 0 (W41, W40): These bits select the number of program wait states when area 4 in external space is accessed while the AST4 bit in ASTCR is set to 1.

Bit 1 W41	Bit 0 W40	Description
0	0	Program wait not inserted when external space area 4 is accessed
	1	1 program wait state inserted when external space area 4 is accessed
1	0	2 program wait states inserted when external space area 4 is accessed
	1	3 program wait states inserted when external space area 4 is accessed (Initial value)

WCRL

Bit	7	6	5	4	3	2	1	0
	W31	W30	W21	W20	W11	W10	W01	W00
Initial value	1	1	1	1	1	1	1	1
Read/Write	R/W	R/W	R/W	R/W	R/W	R/W	R/W	R/W

Bits 7 and 6—Area 3 Wait Control 1 and 0 (W31, W30): These bits select the number of program wait states when area 3 in external space is accessed while the AST3 bit in ASTCR is set to 1.

Bit 7 W31	Bit 6 W30	Description
0	0	Program wait not inserted when external space area 3 is accessed
	1	1 program wait state inserted when external space area 3 is accessed
1	0	2 program wait states inserted when external space area 3 is accessed
	1	3 program wait states inserted when external space area 3 is accessed (Initial value)

Bits 5 and 4—Area 2 Wait Control 1 and 0 (W21, W20): These bits select the number of program wait states when area 2 in external space is accessed while the AST2 bit in ASTCR is set to 1.

Bit 5 W21	Bit 4 W20	Description
0	0	Program wait not inserted when external space area 2 is accessed
	1	1 program wait state inserted when external space area 2 is accessed
1	0	2 program wait states inserted when external space area 2 is accessed
	1	3 program wait states inserted when external space area 2 is accessed (Initial value)

Bits 3 and 2—Area 1 Wait Control 1 and 0 (W11, W10): These bits select the number of program wait states when area 1 in external space is accessed while the AST1 bit in ASTCR is set to 1.

Bit 3 W11	Bit 2 W10	Description
0	0	Program wait not inserted when external space area 1 is accessed
	1	1 program wait state inserted when external space area 1 is accessed
1	0	2 program wait states inserted when external space area 1 is accessed
	1	3 program wait states inserted when external space area 1 is accessed (Initial value)

Bits 1 and 0—Area 0 Wait Control 1 and 0 (W01, W00): These bits select the number of program wait states when area 0 in external space is accessed while the AST0 bit in ASTCR is set to 1.

Bit 1 W01	Bit 0 W00	Description
0	0	Program wait not inserted when external space area 0 is accessed
	1	1 program wait state inserted when external space area 0 is accessed
1	0	2 program wait states inserted when external space area 0 is accessed
	1	3 program wait states inserted when external space area 0 is accessed (Initial value)

6.2.4 Bus Release Control Register (BRCR)

BRCR is an 8-bit readable/writable register that enables address output on bus lines A_{23} to A_{20} and enables or disables release of the bus to an external device.

Bit								
	7	6	5	4	3	2	1	0
	A23E	A22E	A21E	A20E	—	—	—	BRLE
Modes 1, 2, 6, and 7	Initial value	1	1	1	1	1	1	0
	Read/Write	—	—	—	—	—	—	R/W
Modes 3 and 4	Initial value	1	1	0	1	1	1	0
	Read/Write	R/W	R/W	R/W	—	—	—	R/W
Mode 5	Initial value	1	1	1	1	1	1	0
	Read/Write	R/W	R/W	R/W	R/W	—	—	R/W

Address 23 to 20 enable These bits enable PA_7 to PA_4 to be used for A_{23} to A_{20} address output				Reserved bits			Bus release enable Enables or disables release of the bus to an external device	

BRCR is initialized to H'FE in modes 1, 2, 5, 6, and 7, and to H'EE in modes 3 and 4, by a reset and in hardware standby mode. It is not initialized in software standby mode.

Bit 7—Address 23 Enable (A23E): Enables PA_4 to be used as the A_{23} address output pin. Writing 0 in this bit enables A_{23} output from PA_4 . In modes other than 3, 4, and 5, this bit cannot be modified and PA_4 has its ordinary port functions.

Bit 7 A23E	Description
0	PA_4 is the A_{23} address output pin
1	PA_4 is an input/output pin (Initial value)

Bit 6—Address 22 Enable (A22E): Enables PA₅ to be used as the A₂₂ address output pin. Writing 0 in this bit enables A₂₂ output from PA₅. In modes other than 3, 4, and 5, this bit cannot be modified and PA₅ has its ordinary port functions.

Bit 6 A22E	Description
0	PA ₅ is the A ₂₂ address output pin
1	PA ₅ is an input/output pin (Initial value)

Bit 5—Address 21 Enable (A21E): Enables PA₆ to be used as the A₂₁ address output pin. Writing 0 in this bit enables A₂₁ output from PA₆. In modes other than 3, 4, and 5, this bit cannot be modified and PA₆ has its ordinary port functions.

Bit 5 A21E	Description
0	PA ₆ is the A ₂₁ address output pin
1	PA ₆ is an input/output pin (Initial value)

Bit 4—Address 20 Enable (A20E): Enables PA₇ to be used as the A₂₀ address output pin. Writing 0 in this bit enables A₂₀ output from PA₇. This bit can only be modified in mode 5.

Bit 4 A20E	Description
0	PA ₇ is the A ₂₀ address output pin (Initial value when in mode 3 or 4)
1	PA ₇ is an input/output pin (Initial value when in mode 1, 2, 5, 6, or 7)

Bits 3 to 1—Reserved: These bits cannot be modified and are always read as 1.

Bit 0—Bus Release Enable (BRLE): Enables or disables release of the bus to an external device.

Bit 0 BRLE	Description
0	The bus cannot be released to an external device BRE \overline{Q} and B $\overline{A}C\overline{K}$ can be used as input/output pins (Initial value)
1	The bus can be released to an external device

6.2.5 Bus Control Register (BCR)

Bit	7	6	5	4	3	2	1	0
	ICIS1	ICIS0	BROME	BRSTS1	BRSTS0	EMC	RDEA	WAITE
Initial value	1	1	0	0	0	1	1	0
Read/Write	R/W	R/W	R/W	R/W	R/W	R/W	R/W	R/W

BCR is an 8-bit readable/writable register that enables or disables idle cycle insertion, selects the address map, selects the area division unit, and enables or disables $\overline{\text{WAIT}}$ pin input.

BCR is initialized to H'C6 by a reset and in hardware standby mode. It is not initialized in software standby mode.

Bit 7—Idle Cycle Insertion 1 (ICIS1): Selects whether one idle cycle state is to be inserted between bus cycles in case of consecutive external read cycles for different areas.

Bit 7

ICIS1	Description
0	No idle cycle inserted in case of consecutive external read cycles for different areas
1	Idle cycle inserted in case of consecutive external read cycles for different areas (Initial value)

Bit 6—Idle Cycle Insertion 0 (ICIS0): Selects whether one idle cycle state is to be inserted between bus cycles in case of consecutive external read and write cycles.

Bit 6

ICIS0	Description
0	No idle cycle inserted in case of consecutive external read and write cycles
1	Idle cycle inserted in case of consecutive external read and write cycles (Initial value)

Bit 5—Burst ROM Enable (BROME): Selects whether area 0 is a burst ROM interface area.

Bit 5

BROME	Description
0	Area 0 is a basic bus interface area (Initial value)
1	Area 0 is a burst ROM interface area

Bit 4—Burst Cycle Select 1 (BRSTS1): Selects the number of burst cycle states for the burst ROM interface.

Bit 4 BRSTS1	Description
0	Burst access cycle comprises 2 states (Initial value)
1	Burst access cycle comprises 3 states

Bit 3—Burst Cycle Select 0 (BRSTS0): Selects the number of words that can be accessed in a burst ROM interface burst access.

Bit 3 BRSTS0	Description
0	Max. 4 words in burst access (burst access on match of address bits above A3) (Initial value)
1	Max. 8 words in burst access (burst access on match of address bits above A4)

Bit 2—Expansion Memory Map Control (EMC): Selects either of the two memory maps.

Bit 2 EMC	Description
0	Selects the memory map shown in figure 3.2: see section 3.6, Memory Map in Each Operating Mode
1	Selects the memory map shown in figure 3.1: see section 3.6, Memory Map in Each Operating Mode (Initial value)

When EMC is cleared to 0, addresses of some internal I/O registers are moved. For details, refer to appendix B.2, Address List (when EMC = 0).

This bit is invalid in mode 6. In mode 6 and when the RDEA bit is 0, EMC must not be cleared to 0.

Bit 1—Area Division Unit Select (RDEA): Selects the memory map area division units. This bit is valid in modes 3, 4, and 5, and is invalid in modes 1, 2, 6, and 7.

When the EMC bit is 0, RDEA must not be cleared to 0.

Bit 1

RDEA	Description								
0	Area divisions are as follows: <table style="margin-left: 40px; border: none;"> <tr> <td>Area 0: 2 Mbytes</td> <td>Area 4: 1.93 Mbytes</td> </tr> <tr> <td>Area 1: 2 Mbytes</td> <td>Area 5: 4 kbytes</td> </tr> <tr> <td>Area 2: 8 Mbytes</td> <td>Area 6: 23.75 kbytes</td> </tr> <tr> <td>Area 3: 2 Mbytes</td> <td>Area 7: 22 bytes</td> </tr> </table>	Area 0: 2 Mbytes	Area 4: 1.93 Mbytes	Area 1: 2 Mbytes	Area 5: 4 kbytes	Area 2: 8 Mbytes	Area 6: 23.75 kbytes	Area 3: 2 Mbytes	Area 7: 22 bytes
Area 0: 2 Mbytes	Area 4: 1.93 Mbytes								
Area 1: 2 Mbytes	Area 5: 4 kbytes								
Area 2: 8 Mbytes	Area 6: 23.75 kbytes								
Area 3: 2 Mbytes	Area 7: 22 bytes								
1	Areas 0 to 7 are the same size (2 Mbytes) (Initial value)								

Bit 0—WAIT Pin Enable (WAITE): Enables or disables wait insertion by means of the $\overline{\text{WAIT}}$ pin.

Bit 0

WAITE	Description
0	$\overline{\text{WAIT}}$ pin wait input is disabled, and the $\overline{\text{WAIT}}$ pin can be used as an input/output port (Initial value)
1	$\overline{\text{WAIT}}$ pin wait input is enabled

6.2.6 Chip Select Control Register (CSCR)

CSCR is an 8-bit readable/writable register that enables or disables output of chip select signals (\overline{CS}_7 to \overline{CS}_4).

If output of a chip select signal is enabled by a setting in this register, the corresponding pin functions as a chip select signal (\overline{CS}_7 to \overline{CS}_4) output regardless of any other settings. CSCR cannot be modified in single-chip mode.

Bit	7	6	5	4	3	2	1	0
	CS7E	CS6E	CS5E	CS4E	—	—	—	—
Initial value	0	0	0	0	1	1	1	1
Read/Write	R/W	R/W	R/W	R/W	—	—	—	—

Chip select 7 to 4 enable
These bits enable or disable
chip select signal output
Reserved bits

CSCR is initialized to H'0F by a reset and in hardware standby mode. It is not initialized in software standby mode.

Bits 7 to 4—Chip Select 7 to 4 Enable (CS7E to CS4E): These bits enable or disable output of the corresponding chip select signal.

Bit n CSnE	Description
0	Output of chip select signal \overline{CS}_n is disabled (Initial value)
1	Output of chip select signal \overline{CS}_n is enabled

Note: n = 7 to 4

Bits 3 to 0—Reserved: These bits cannot be modified and are always read as 1.

6.2.7 DRAM Control Register A (DRCRA)

Bit	7	6	5	4	3	2	1	0
	DRAS2	DRAS1	DRAS0	—	BE	RDM	SRFMD	RFSHE
Initial value	0	0	0	1	0	0	0	0
Read/Write	R/W	R/W	R/W	—	R/W	R/W	R/W	R/W

DRCRA is an 8-bit readable/writable register that selects the areas that have a DRAM interface function, and the access mode, and enables or disables self-refreshing and refresh pin output.

DRCRA is initialized to H'10 by a reset and in hardware standby mode. It is not initialized in software standby mode.

Bits 7 to 5—DRAM Area Select (DRAS2 to DRAS0): These bits select which of areas 2 to 5 are to function as DRAM interface areas (DRAM space) in expanded mode, and at the same time select the $\overline{\text{RAS}}$ output pin corresponding to each DRAM space.

			Description			
Bit 7 DRAS2	Bit 6 DRAS1	Bit 5 DRAS0	Area 5	Area 4	Area 3	Area 2
0	0	0	Normal	Normal	Normal	Normal
		1	Normal	Normal	Normal	DRAM space ($\overline{\text{CS}}_2$)
	1	0	Normal	Normal	DRAM space ($\overline{\text{CS}}_3$)	DRAM space ($\overline{\text{CS}}_2$)
		1	Normal	Normal	DRAM space ($\overline{\text{CS}}_2$)*	DRAM space ($\overline{\text{CS}}_2$)*
1	0	0	Normal	DRAM space ($\overline{\text{CS}}_4$)	DRAM space ($\overline{\text{CS}}_3$)	DRAM space ($\overline{\text{CS}}_2$)
		1	DRAM space ($\overline{\text{CS}}_5$)	DRAM space ($\overline{\text{CS}}_4$)	DRAM space ($\overline{\text{CS}}_3$)	DRAM space ($\overline{\text{CS}}_2$)
	1	0	DRAM space ($\overline{\text{CS}}_4$)*	DRAM space ($\overline{\text{CS}}_4$)*	DRAM space ($\overline{\text{CS}}_2$)*	DRAM space ($\overline{\text{CS}}_2$)*
		1	DRAM space ($\overline{\text{CS}}_2$)*	DRAM space ($\overline{\text{CS}}_2$)*	DRAM space ($\overline{\text{CS}}_2$)*	DRAM space ($\overline{\text{CS}}_2$)*

Note: * A single $\overline{\text{CS}}_n$ pin serves as a common $\overline{\text{RAS}}$ output pin for a number of areas. Unused $\overline{\text{CS}}_n$ pins can be used as input/output ports.

When any of bits DRAS2 to DRAS0 is set to 1 in expanded mode, it is not possible to write to DRCRB, RTMCSR, RTCNT, or RTCOR. However, 0 can be written to the CMF flag in RTMCSR to clear the flag.

When an arbitrary value has been set in DRAS2 to DRAS0, a write of a different value other than 000 must not be performed.

Bit 4—Reserved: This bit cannot be modified and is always read as 1.

Bit 3—Burst Access Enable (BE): Enables or disables burst access to DRAM space. DRAM space burst access is performed in fast page mode.

Bit 3

BE	Description	
0	Burst disabled (always full access)	(Initial value)
1	DRAM space access performed in fast page mode	

Bit 2—RAS Down Mode (RDM): Selects whether to wait for the next DRAM access with the $\overline{\text{RAS}}$ signal held low (RAS down mode), or to drive the RAS signal high again (RAS up mode), when burst access is enabled for DRAM space (BE = 1), and access to DRAM is interrupted.

Caution is required when the $\overline{\text{HWR}}$ and $\overline{\text{LWR}}$ are used as the $\overline{\text{UCAS}}$ and $\overline{\text{LCAS}}$ output pins. For details, see RAS Down Mode and RAS Up Mode in section 6.5.10, Burst Operation.

Bit 2

RDM	Description	
0	DRAM interface: RAS up mode selected	(Initial value)
1	DRAM interface: RAS down mode selected	

Bit 1—Self-Refresh Mode (SRFMD): Specifies DRAM self-refreshing in software standby mode.

When any of areas 2 to 5 is designated as DRAM space, DRAM self-refreshing is possible when a transition is made to software standby mode after the SRFMD bit has been set to 1.

The normal access state is restored when software standby mode is exited, regardless of the SRFMD setting.

Bit 1 SRFMD	Description
0	DRAM self-refreshing disabled in software standby mode (Initial value)
1	DRAM self-refreshing enabled in software standby mode

Bit 0—Refresh Pin Enable (RFSHE): Enables or disables $\overline{\text{RFSH}}$ pin refresh signal output. If areas 2 to 5 are not designated as DRAM space, this bit should not be set to 1.

Bit 0 RFSHE	Description
0	$\overline{\text{RFSH}}$ pin refresh signal output disabled (Initial value) ($\overline{\text{RFSH}}$ pin can be used as input/output port)
1	$\overline{\text{RFSH}}$ pin refresh signal output enabled

6.2.8 DRAM Control Register B (DRCRB)

Bit	7	6	5	4	3	2	1	0
	MXC1	MXC0	CSEL	RCYCE	—	TPC	RCW	RLW
Initial value	0	0	0	0	1	0	0	0
Read/Write	R/W	R/W	R/W	R/W	—	R/W	R/W	R/W

DRCRB is an 8-bit readable/writable register that selects the number of address multiplex column address bits for the DRAM interface, the column address strobe output pin, enabling or disabling of refresh cycle insertion, the number of precharge cycles, enabling or disabling of wait state insertion between $\overline{\text{RAS}}$ and $\overline{\text{CAS}}$, and enabling or disabling of wait state insertion in refresh cycles.

DRCRB is initialized to H'08 by a reset and in hardware standby mode. It is not initialized in software standby mode.

The settings in this register are invalid when bits DRAS2 to DRAS0 in DRCRA are all 0.

Bits 7 and 6—Multiplex Control 1 and 0 (MXC1, MXC0): These bits select the row address/column address multiplexing method used on the DRAM interface. In burst operation, the row address used for comparison is determined by the setting of these bits and the bus width of the relevant area set in ABWCR.

Bit 7 MXC1	Bit 6 MXC0	Description		
0	0	Column address: 8 bits		
		Compared address:		
		Modes 1, 2	8-bit access space A ₁₉ to A ₈	
			16-bit access space A ₁₉ to A ₉	
	1	Modes 3, 4, 5	8-bit access space A ₂₃ to A ₈	
			16-bit access space A ₂₃ to A ₉	
		1	Column address: 9 bits	Compared address:
				Modes 1, 2
	16-bit access space A ₁₉ to A ₁₀			
Modes 3, 4, 5	8-bit access space A ₂₃ to A ₉			
	16-bit access space A ₂₃ to A ₁₀			
1	0	Column address: 10 bits		
		Compared address:		
		Modes 1, 2	8-bit access space A ₁₉ to A ₁₀	
			16-bit access space A ₁₉ to A ₁₁	
	1	Modes 3, 4, 5	8-bit access space A ₂₃ to A ₁₀	
			16-bit access space A ₂₃ to A ₁₁	
		1	Illegal setting	

Bit 5—CAS Output Pin Select (CSEL): Selects the \overline{UCAS} and \overline{LCAS} output pins when areas 2 to 5 are designated as DRAM space.

Bit 5 CSEL	Description
0	PB4 and PB5 selected as \overline{UCAS} and \overline{LCAS} output pins (Initial value)
1	\overline{HWR} and \overline{LWR} selected as \overline{UCAS} and \overline{LCAS} output pins

Bit 4—Refresh Cycle Enable (RCYCE): Enables or disables CAS-before-RAS refresh cycle insertion. When none of areas 2 to 5 has been designated as DRAM space, refresh cycles are not inserted regardless of the setting of this bit.

Bit 4

RCYCE	Description	
0	Refresh cycles disabled	(Initial value)
1	DRAM refresh cycles enabled	

Bit 3—Reserved: This bit cannot be modified and is always read as 1.

Bit 2—TP Cycle Control (TPC): Selects whether a 1-state or two-state precharge cycle (TP) is to be used for DRAM read/write cycles and CAS-before-RAS refresh cycles.

The setting of this bit does not affect the self-refresh function.

Bit 2

TPC	Description	
0	1-state precharge cycle inserted	(Initial value)
1	2-state precharge cycle inserted	

Bit 1— $\overline{\text{RAS-CAS}}$ Wait (RCW): Controls wait state (T_{rw}) insertion between T_r and T_{c1} in DRAM read/write cycles. The setting of this bit does not affect refresh cycles.

Bit 1

RCW	Description	
0	Wait state (T_{rw}) insertion disabled	(Initial value)
1	One wait state (T_{rw}) inserted	

Bit 0—Refresh Cycle Wait Control (RLW): Controls wait state (T_{RW}) insertion for CAS-before-RAS refresh cycles. The setting of this bit does not affect DRAM read/write cycles.

Bit 0

RLW	Description	
0	Wait state (T_{RW}) insertion disabled	(Initial value)
1	One wait state (T_{RW}) inserted	

6.2.9 Refresh Timer Control/Status Register (RTMCSR)

Bit	7	6	5	4	3	2	1	0
	CMF	CMIE	CKS2	CKS1	CKS0	—	—	—
Initial value	0	0	0	0	0	1	1	1
Read/Write	R(W)*	R/W	R/W	R/W	R/W	—	—	—

RTMCSR is an 8-bit readable/writable register that selects the refresh timer counter clock. When the refresh timer is used as an interval timer, RTMCSR also enables or disables interrupt requests. Bits 7 and 6 of RTMCSR are initialized to 0 by a reset and in the standby modes. Bits 5 to 3 are initialized to 0 by a reset and in hardware standby mode; they are not initialized in software standby mode.

Note: * Only 0 can be written to clear the flag.

Bit 7—Compare Match Flag (CMF): Status flag that indicates a match between the values of RTCNT and RTCOR.

Bit 7

CMF	Description
0	Clearing conditions When the chip is reset and in standby mode Read CMF when CMF = 1, then write 0 in CMF (Initial value)
1	Setting condition When RTCNT = RTCOR

Bit 6—Compare Match Interrupt Enable (CMIE): Enables or disables the CMI interrupt requested when the CMF flag is set to 1 in RTMCSR. The CMIE bit is always cleared to 0 when any of areas 2 to 5 is designated as DRAM space.

Bit 6

CMIE	Description
0	The CMI interrupt requested by CMF is disabled (Initial value)
1	The CMI interrupt requested by CMF is enabled

Bits 5 to 3—Refresh Counter Clock Select (CKS2 to CKS0): These bits select the clock to be input to RTCNT from among 7 clocks obtained by dividing the system clock (ϕ). When the input clock is selected with bits CKS2 to CKS0, RTCNT begins counting up.

Bit 5 CKS2	Bit 4 CKS1	Bit 3 CKS0	Description	(Initial value)
0	0	0	Count operation halted	
		1	$\phi/2$ used as counter clock	
	1	0	$\phi/8$ used as counter clock	
		1	$\phi/32$ used as counter clock	
1	0	0	$\phi/128$ used as counter clock	
		1	$\phi/512$ used as counter clock	
	1	0	$\phi/2048$ used as counter clock	
		1	$\phi/4096$ used as counter clock	

Bits 2 to 0—Reserved: These bits cannot be modified and are always read as 1.

6.2.10 Refresh Timer Counter (RTCNT)

Bit	7	6	5	4	3	2	1	0
Initial value	0	0	0	0	0	0	0	0
Read/Write	R/W	R/W	R/W	R/W	R/W	R/W	R/W	R/W

RTCNT is an 8-bit readable/writable up-counter.

RTCNT is incremented by an internal clock selected by bits CKS2 to CKS0 in RTMCSR. When RTCNT matches RTCOR (compare match), the CMF flag in RTMCSR is set to 1 and RTCNT is cleared to H'00. If the RCYCE bit in DRCRB is set to 1 at this time, a refresh cycle is started. Also, if the CMIE bit in RTMCSR is set to 1, a compare match interrupt (CMI) is generated.

RTCNT is initialized to H'00 by a reset and in standby mode.

6.2.11 Refresh Time Constant Register (RTCOR)

Bit	7	6	5	4	3	2	1	0
Initial value	1	1	1	1	1	1	1	1
Read/Write	R/W	R/W	R/W	R/W	R/W	R/W	R/W	R/W

RTCOR is an 8-bit readable/writable register that determines the interval at which RTCNT is cleared.

RTCOR and RTCNT are constantly compared. When their values match, the CMF flag is set to 1 in RTMCSR, and RTCNT is simultaneously cleared to H'00.

RTCOR is initialized to H'FF by a reset and in hardware standby mode. It is not initialized in software standby mode.

Note: Only byte access can be used on this register.

6.2.12 Address Control Register (ADRCR)

ADRCR is an 8-bit readable/writable register that selects either address update mode 1 or address update mode 2 as the address output method.

Bit	7	6	5	4	3	2	1	0
	—	—	—	—	—	—	—	ADRCTL
Initial value	1	1	1	1	1	1	1	1
R/W	—	—	—	—	—	—	—	R/W

Reserved bits
Address control
Selects address update mode 1 or address update mode 2

ADRCR is initialized to H'FF by a reset and in hardware standby mode. It is not initialized in software standby mode.

Bits 7 to 2—Reserved: These bits cannot be modified and are always read as 1.

Bit 1—Reserved: This bit is always read as 1. Do not write 0 to this bit.

Bit 0—Address Control (ADRCTL): Selects the address output method.

Bit 0

ADRCTL	Description
0	Address update mode 2 is selected
1	Address update mode 1 is selected (Initial value)

6.3 Operation

6.3.1 Area Division

The external address space is divided into areas 0 to 7. Each area has a size of 128 kbytes in the 1-Mbyte modes, or 2-Mbytes in the 16-Mbyte modes. Figure 6.2 shows a general view of the memory map.

H' 00000	Area 0 (128 kbytes)	H' 000000	Area 0 (2 Mbytes)
H' 1FFFF		H' 1FFFFFF	
H' 20000	Area 1 (128 kbytes)	H' 200000	Area 1 (2 Mbytes)
H' 3FFFF		H' 3FFFFFF	
H' 40000	Area 2 (128 kbytes)	H' 400000	Area 2 (2 Mbytes)
H' 5FFFF		H' 5FFFFFF	
H' 60000	Area 3 (128 kbytes)	H' 600000	Area 3 (2 Mbytes)
H' 7FFFF		H' 7FFFFFF	
H' 80000	Area 4 (128 kbytes)	H' 800000	Area 4 (2 Mbytes)
H' 9FFFF		H' 9FFFFFF	
H' A0000	Area 5 (128 kbytes)	H' A00000	Area 5 (2 Mbytes)
H' BFFFF		H' BFFFFFF	
H' C0000	Area 6 (128 kbytes)	H' C00000	Area 6 (2 Mbytes)
H' DFFFF		H' DFFFFFF	
H' E0000	Area 7 (128 kbytes)	H' E00000	Area 7 (2 Mbytes)
H' FFFFF		H' FFFFFFF	
(a) 1-Mbyte modes (modes 1, and 2)		(b) 16-Mbyte modes (modes 3, 4, and 5)	

Figure 6.2 Access Area Map for Each Operating Mode

Chip select signals (\overline{CS}_0 to \overline{CS}_7) can be output for areas 0 to 7. The bus specifications for each area are selected in ABWCR, ASTCR, WCRH, and WCRL.

In 16-Mbyte mode, the area division units can be selected with the RDEA bit in BCR.

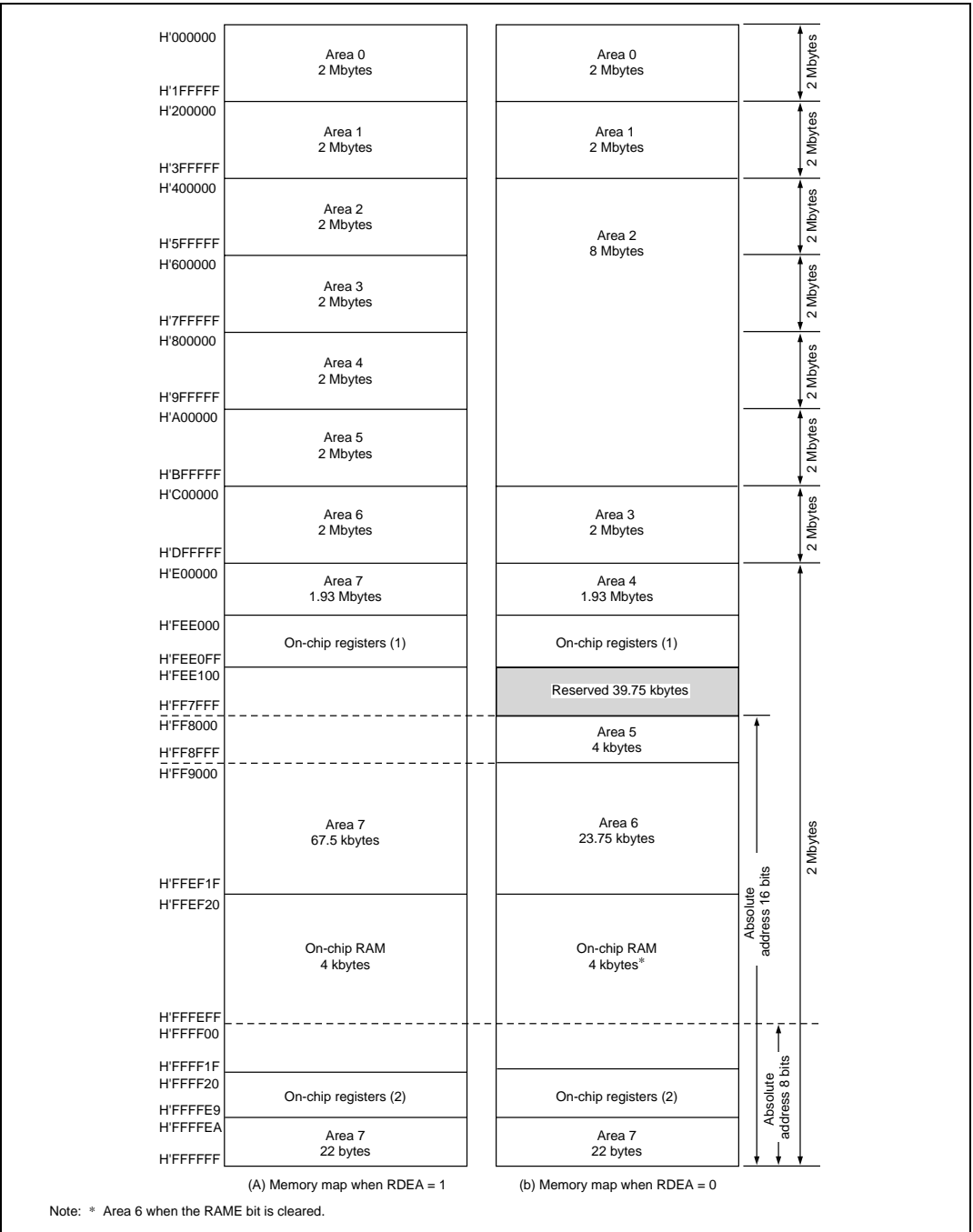

Figure 6.3 Memory Map in 16-Mbyte Mode

6.3.2 Bus Specifications

The external space bus specifications consist of three elements: (1) bus width, (2) number of access states, and (3) number of program wait states.

The bus width and number of access states for on-chip memory and registers are fixed, and are not affected by the bus controller.

Bus Width: A bus width of 8 or 16 bits can be selected with ABWCR. An area for which an 8-bit bus is selected functions as an 8-bit access space, and an area for which a 16-bit bus is selected functions as a 16-bit access space.

If all areas are designated for 8-bit access, 8-bit bus mode is set; if any area is designated for 16-bit access, 16-bit bus mode is set.

Number of Access States: Two or three access states can be selected with ASTCR. An area for which two-state access is selected functions as a two-state access space, and an area for which three-state access is selected functions as a three-state access space.

DRAM space is accessed in four states regardless of the ASTCR settings.

When two-state access space is designated, wait insertion is disabled.

Number of Program Wait States: When three-state access space is designated in ASTCR, the number of program wait states to be inserted automatically is selected with WCRH and WCRL. From 0 to 3 program wait states can be selected.

When ASTCR is cleared to 0 for DRAM space, a program wait (T_{c1} - T_{c2} wait) is not inserted. Also, no program wait is inserted in burst ROM space burst cycles.

Table 6.3 shows the bus specifications for each basic bus interface area.

Table 6.3 Bus Specifications for Each Area (Basic Bus Interface)

ABWCR	ASTCR	WCRH/WCRL		Bus Specifications (Basic Bus Interface)		
ABWn	ASTn	Wn1	Wn0	Bus Width	Access States	Program Wait States
0	0	—	—	16	2	0
	1	0	0		3	0
			1		1	
			1		0	2
		1	3			
1	0	—	—	8	2	0
	1	0	0		3	0
			1		1	
			1		0	2
		1	3			

Note: n = 7 to 0

6.3.3 Memory Interfaces

The H8/3068F memory interfaces comprise a basic bus interface that allows direct connection of ROM, SRAM, and so on; a DRAM interface that allows direct connection of DRAM; and a burst ROM interface that allows direct connection of burst ROM. The interface can be selected independently for each area.

An area for which the basic bus interface is designated functions as normal space, an area for which the DRAM interface is designated functions as DRAM space, and area 0 for which the burst ROM interface is designated functions as burst ROM space.

6.3.4 Chip Select Signals

For each of areas 0 to 7, the H8/3068F can output a chip select signal (\overline{CS}_0 to \overline{CS}_7) that goes low when the corresponding area is selected in expanded mode. Figure 6.4 shows the output timing of a \overline{CS}_n signal.

Output of \overline{CS}_0 to \overline{CS}_3 : Output of \overline{CS}_0 to \overline{CS}_3 is enabled or disabled in the data direction register (DDR) of the corresponding port.

In the expanded modes with on-chip ROM disabled, a reset leaves pin \overline{CS}_0 in the output state and pins \overline{CS}_1 to \overline{CS}_3 in the input state. To output chip select signals \overline{CS}_1 to \overline{CS}_3 , the corresponding DDR bits must be set to 1. In the expanded modes with on-chip ROM enabled, a reset leaves pins \overline{CS}_0 to \overline{CS}_3 in the input state. To output chip select signals \overline{CS}_0 to \overline{CS}_3 , the corresponding DDR bits must be set to 1. For details, see section 8, I/O Ports.

Output of \overline{CS}_4 to \overline{CS}_7 : Output of \overline{CS}_4 to \overline{CS}_7 is enabled or disabled in the chip select control register (CSCR). A reset leaves pins \overline{CS}_4 to \overline{CS}_7 in the input state. To output chip select signals \overline{CS}_4 to \overline{CS}_7 , the corresponding CSCR bits must be set to 1. For details, see section 8, I/O Ports.

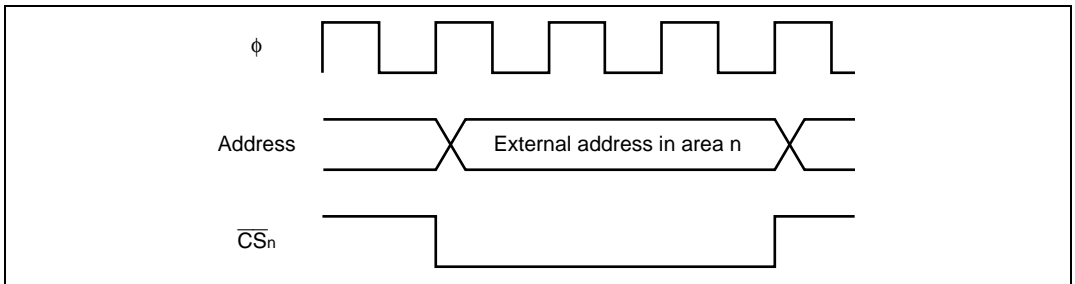

Figure 6.4 \overline{CS}_n Signal Output Timing (n = 0 to 7)

When the on-chip ROM, on-chip RAM, and on-chip registers are accessed, \overline{CS}_0 to \overline{CS}_7 remain high. The \overline{CS}_n signals are decoded from the address signals. They can be used as chip select signals for SRAM and other devices.

6.3.5 Address Output Method

The H8/3068F provides a choice of two address update methods: either the same method as in the previous H8/300H Series (address update mode 1), or a method in which address update is restricted to external space accesses or self-refresh cycles (address update mode 2).

Figure 6.5 shows examples of address output in these two update modes.

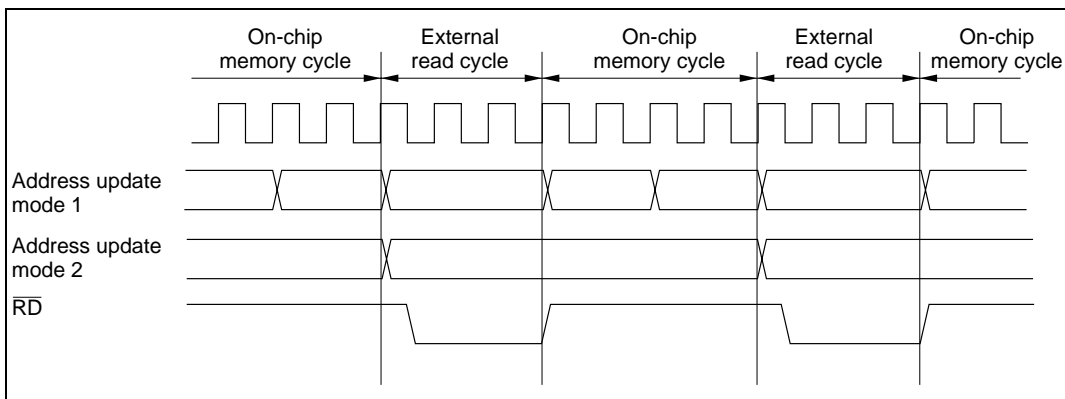

**Figure 6.5 Sample Address Output in Each Address Update Mode
(Basic Bus Interface, 3-State Space)**

Address Update Mode 1: Address update mode 1 is compatible with the previous H8/300H Series. Addresses are always updated between bus cycles.

Address Update Mode 2: In address update mode 2, address updating is performed only in external space accesses or self-refresh cycles. In this mode, the address can be retained between an external space read cycle and an instruction fetch cycle (on-chip memory) by placing the program in on-chip memory. Address update mode 2 is therefore useful when connecting a device that requires address hold time with respect to the rise of the \overline{RD} strobe.

Switching between address update modes 1 and 2 is performed by means of the ADRCTL bit in ADRCR. The initial value of ADRCR is the address update mode 1 setting, providing compatibility with the previous H8/300H Series.

Cautions: When using address update modes, the following points should be noted.

- When address update mode 2 is selected, the address in an internal space (on-chip memory or internal I/O) access cycle is not output externally.
- In order to secure address holding with respect to the rise of \overline{RD} , when address update mode 2 is used an external space read access must be completed within a single access cycle. For example, in a word access to 8-bit access space, the bus cycle is split into two as shown in figure 6.6., and so there is not a single access cycle. In this case, address holding is not guaranteed at the rise of \overline{RD} between the first (even address) and second (odd address) access cycles (area inside the ellipse in the figure).

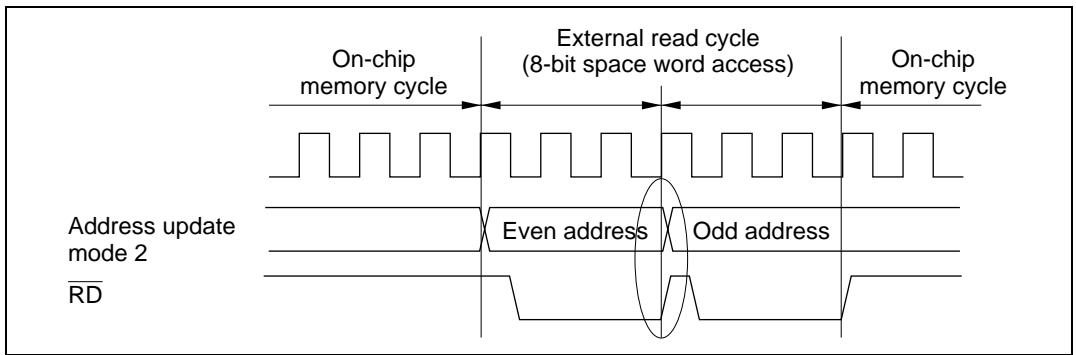

Figure 6.6 Example of Consecutive External Space Accesses in Address Update Mode 2

- When address update mode 2 is selected, in a DRAM space CAS-before-RAS (CBR) refresh cycle the previous address is retained (the area 2 start address is not output).

6.4 Basic Bus Interface

6.4.1 Overview

The basic bus interface enables direct connection of ROM, SRAM, and so on.

The bus specifications can be selected with ABWCR, ASTCR, WCRH, and WCRL (see table 6.3).

6.4.2 Data Size and Data Alignment

Data sizes for the CPU and other internal bus masters are byte, word, and longword. The bus controller has a data alignment function, and when accessing external space, controls whether the upper data bus (D_{15} to D_8) or lower data bus (D_7 to D_0) is used according to the bus specifications for the area being accessed (8-bit access area or 16-bit access area) and the data size.

8-Bit Access Areas: Figure 6.7 illustrates data alignment control for 8-bit access space. With 8-bit access space, the upper data bus (D_{15} to D_8) is always used for accesses. The amount of data that can be accessed at one time is one byte: a word access is performed as two byte accesses, and a longword access, as four byte accesses.

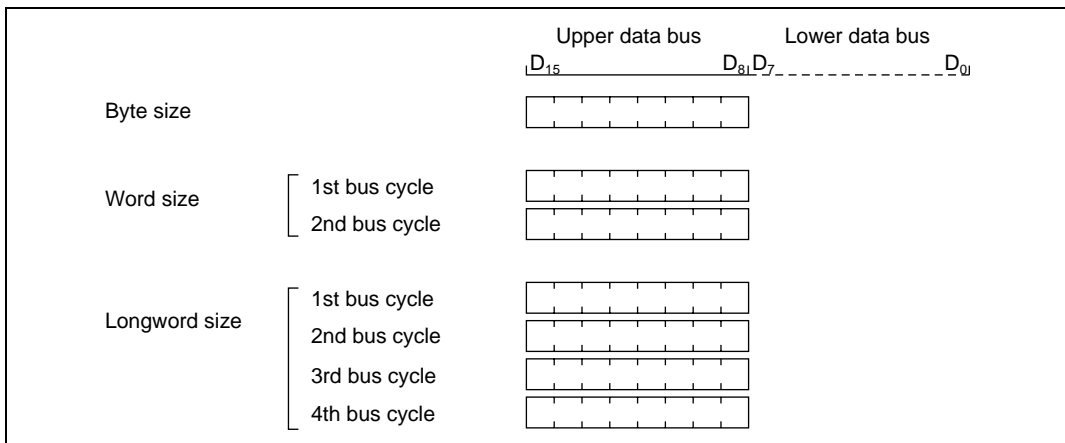

Figure 6.7 Access Sizes and Data Alignment Control (8-Bit Access Area)

16-Bit Access Areas: Figure 6.8 illustrates data alignment control for 16-bit access areas. With 16-bit access areas, the upper data bus (D_{15} to D_8) and lower data bus (D_7 to D_0) are used for accesses. The amount of data that can be accessed at one time is one byte or one word, and a longword access is executed as two word accesses.

In byte access, whether the upper or lower data bus is used is determined by whether the address is even or odd. The upper data bus is used for an even address, and the lower data bus for an odd address.

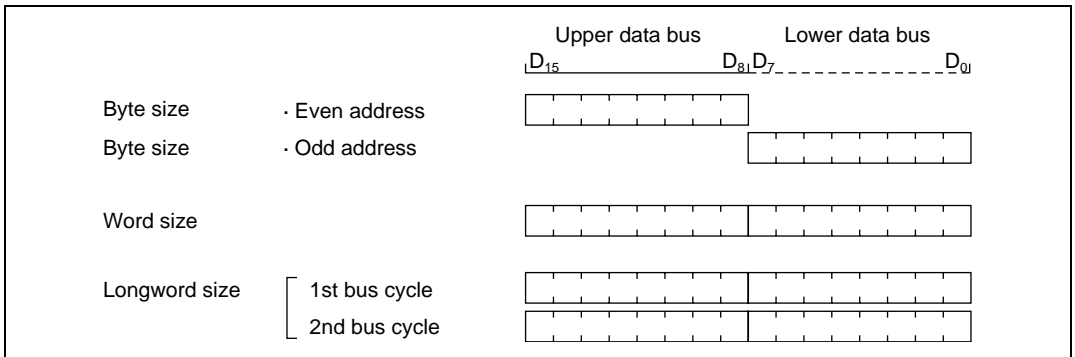

Figure 6.8 Access Sizes and Data Alignment Control (16-Bit Access Area)

6.4.3 Valid Strobes

Table 6.4 shows the data buses used, and the valid strobes, for the access spaces.

In a read, the \overline{RD} signal is valid for both the upper and the lower half of the data bus.

In a write, the \overline{HWR} signal is valid for the upper half of the data bus, and the \overline{LWR} signal for the lower half.

Table 6.4 Data Buses Used and Valid Strobes

Area	Access Size	Read/Write	Address	Valid Strobe	Upper Data Bus	Lower Data Bus
					(D ₁₅ to D ₈)	(D ₇ to D ₀)
8-bit access area	Byte	Read	—	\overline{RD}	Valid	Invalid
		Write	—	\overline{HWR}		Undetermined data
16-bit access area	Byte	Read	Even	\overline{RD}	Valid	Invalid
			Odd		Invalid	Valid
	Write	Even	\overline{HWR}	Valid	Undetermined data	
		Odd	\overline{LWR}	Undetermined data	Valid	
Word	Read	—	\overline{RD}	Valid	Valid	
	Write	—	$\overline{HWR}, \overline{LWR}$	Valid	Valid	

Notes: 1. Undetermined data means that unpredictable data is output.
 2. Invalid means that the bus is in the input state and the input is ignored.

6.4.4 Memory Areas

The initial state of each area is basic bus interface, three-state access space. The initial bus width is selected according to the operating mode. The bus specifications described here cover basic items only, and the following sections should be referred to for further details: 6.4, Basic Bus Interface, 6.5, DRAM Interface, 6.8, Burst ROM Interface.

Area 0: Area 0 includes on-chip ROM, and in ROM-disabled expansion mode, all of area 0 is external space. In ROM-enabled expansion mode, the space excluding on-chip ROM is external space.

When area 0 external space is accessed, the \overline{CS}_0 signal can be output.

Either basic bus interface or burst ROM interface can be selected for area 0.

The size of area 0 is 128 kbytes in modes 1 and 2, and 2 Mbytes in modes 3, 4, and 5.

Areas 1 and 6: In external expansion mode, areas 1 and 6 are entirely external space.

When area 1 and 6 external space is accessed, the \overline{CS}_1 and \overline{CS}_6 pin signals respectively can be output.

Only the basic bus interface can be used for areas 1 and 6.

The size of areas 1 and 6 is 128 kbytes in modes 1 and 2, and 2 Mbytes in modes 3, 4, and 5.

Areas 2 to 5: In external expansion mode, areas 2 to 5 are entirely external space.

When area 2 to 5 external space is accessed, signals \overline{CS}_2 to \overline{CS}_5 can be output.

Basic bus interface or DRAM interface can be selected for areas 2 to 5. With the DRAM interface, signals \overline{CS}_2 to \overline{CS}_5 are used as \overline{RAS} signals.

The size of areas 2 to 5 is 128 kbytes in modes 1 and 2, and 2 Mbytes in modes 3, 4, and 5.

Area 7: Area 7 includes the on-chip RAM and registers. In external expansion mode, the space excluding the on-chip RAM and registers is external space. The on-chip RAM is enabled when the RAME bit in the system control register (SYSCR) is set to 1; when the RAME bit is cleared to 0, the on-chip RAM is disabled and the corresponding space becomes external space .

When area 7 external space is accessed, the \overline{CS}_7 signal can be output.

Only the basic bus interface can be used for the area 7 memory interface.

The size of area 7 is 128 kbytes in modes 1 and 2, and 2 Mbytes in modes 3, 4, and 5.

6.4.5 Basic Bus Control Signal Timing

8-Bit, Three-State-Access Areas

Figure 6.9 shows the timing of bus control signals for an 8-bit, three-state-access area. The upper data bus (D_{15} to D_8) is used in accesses to these areas. The \overline{LWR} pin is always high. Wait states can be inserted.

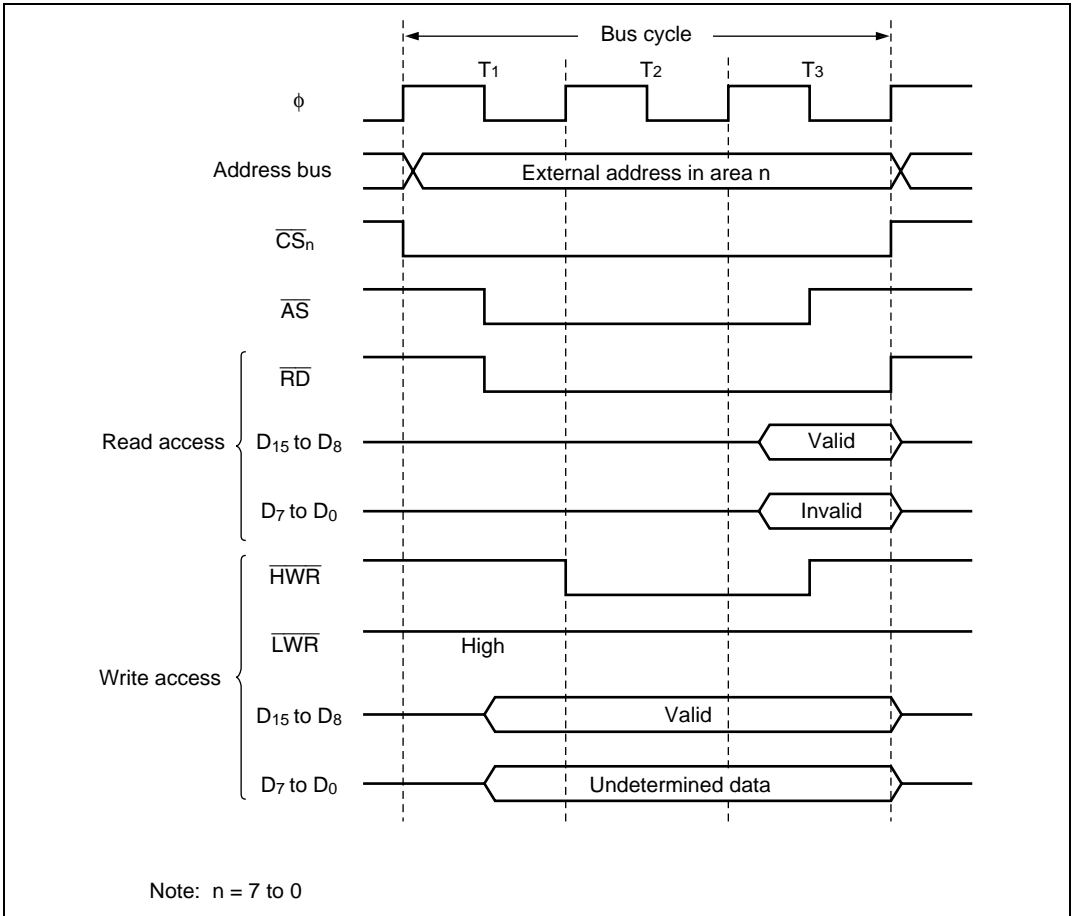

Figure 6.9 Bus Control Signal Timing for 8-Bit, Three-State-Access Area

8-Bit, Two-State-Access Areas

Figure 6.10 shows the timing of bus control signals for an 8-bit, two-state-access area. The upper data bus (D_{15} to D_8) is used in accesses to these areas. The \overline{LWR} pin is always high. Wait states cannot be inserted.

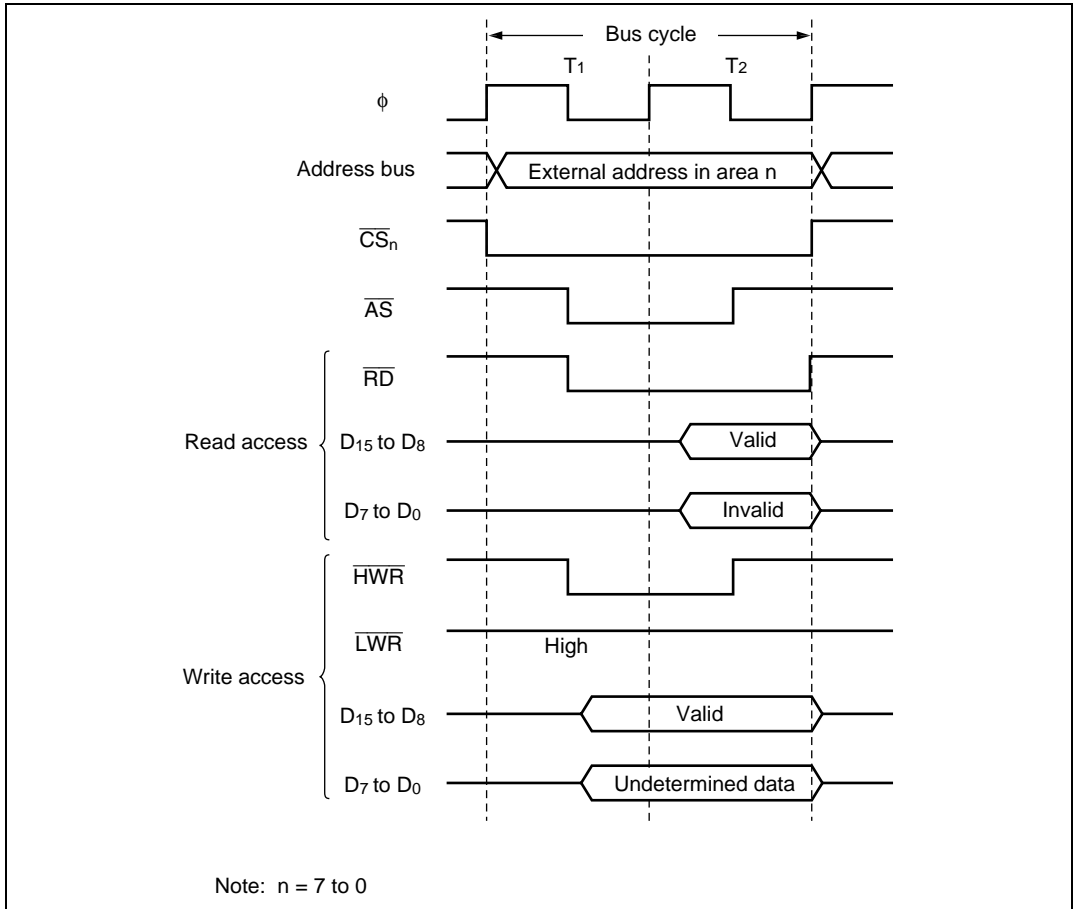
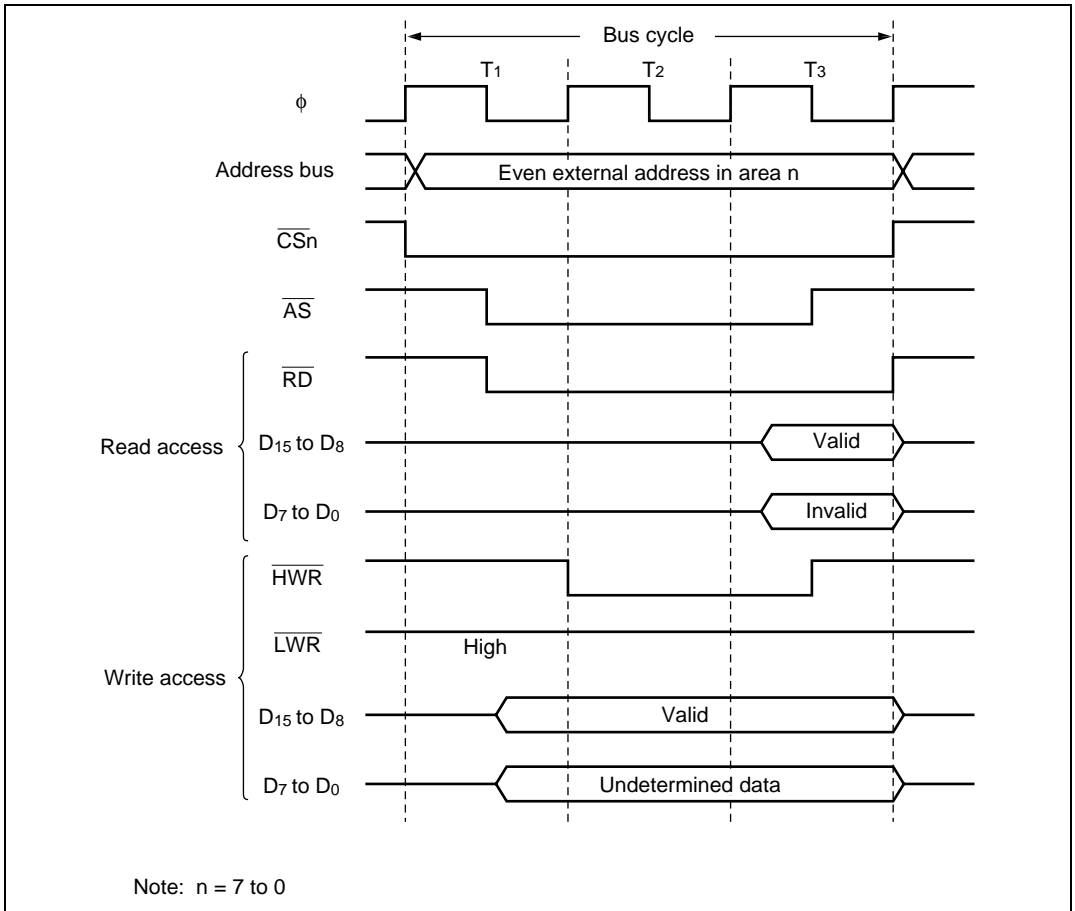

Figure 6.10 Bus Control Signal Timing for 8-Bit, Two-State-Access Area

16-Bit, Three-State-Access Areas

Figures 6.11 to 6.13 show the timing of bus control signals for a 16-bit, three-state-access area. In these areas, the upper data bus (D_{15} to D_8) is used in accesses to even addresses and the lower data bus (D_7 to D_0) in accesses to odd addresses. Wait states can be inserted.



**Figure 6.11 Bus Control Signal Timing for 16-Bit, Three-State-Access Area (1)
(Byte Access to Even Address)**

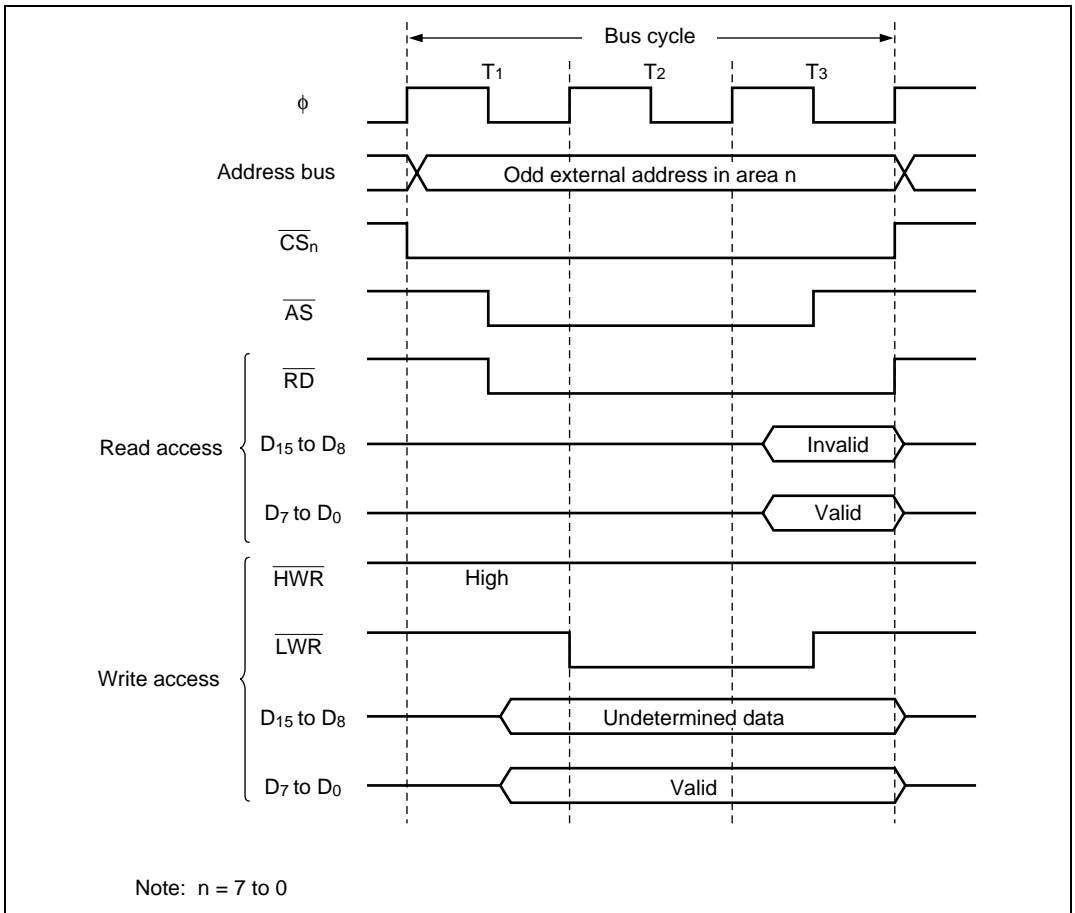

**Figure 6.12 Bus Control Signal Timing for 16-Bit, Three-State-Access Area (2)
(Byte Access to Odd Address)**

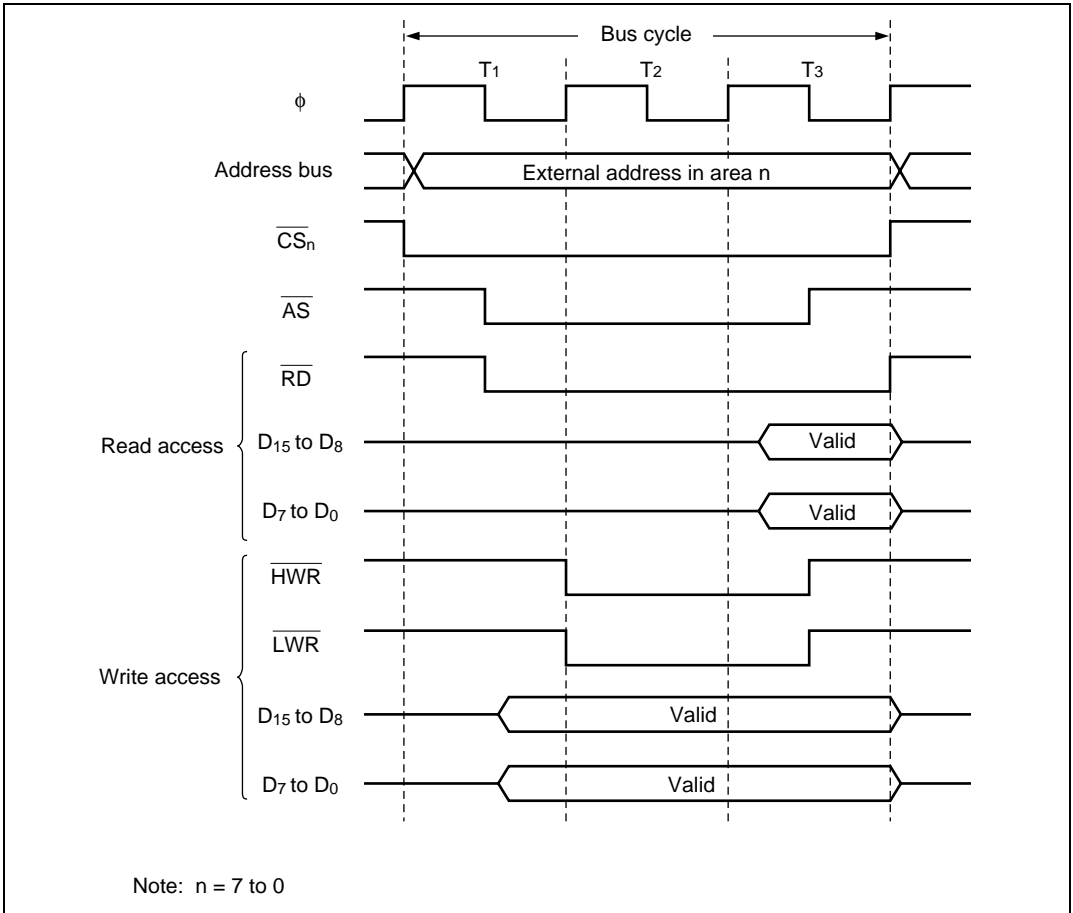

Figure 6.13 Bus Control Signal Timing for 16-Bit, Three-State-Access Area (3) (Word Access)

16-Bit, Two-State-Access Areas: Figures 6.14 to 6.16 show the timing of bus control signals for a 16-bit, two-state-access area. In these areas, the upper data bus (D_{15} to D_8) is used in accesses to even addresses and the lower data bus (D_7 to D_0) in accesses to odd addresses. Wait states cannot be inserted.

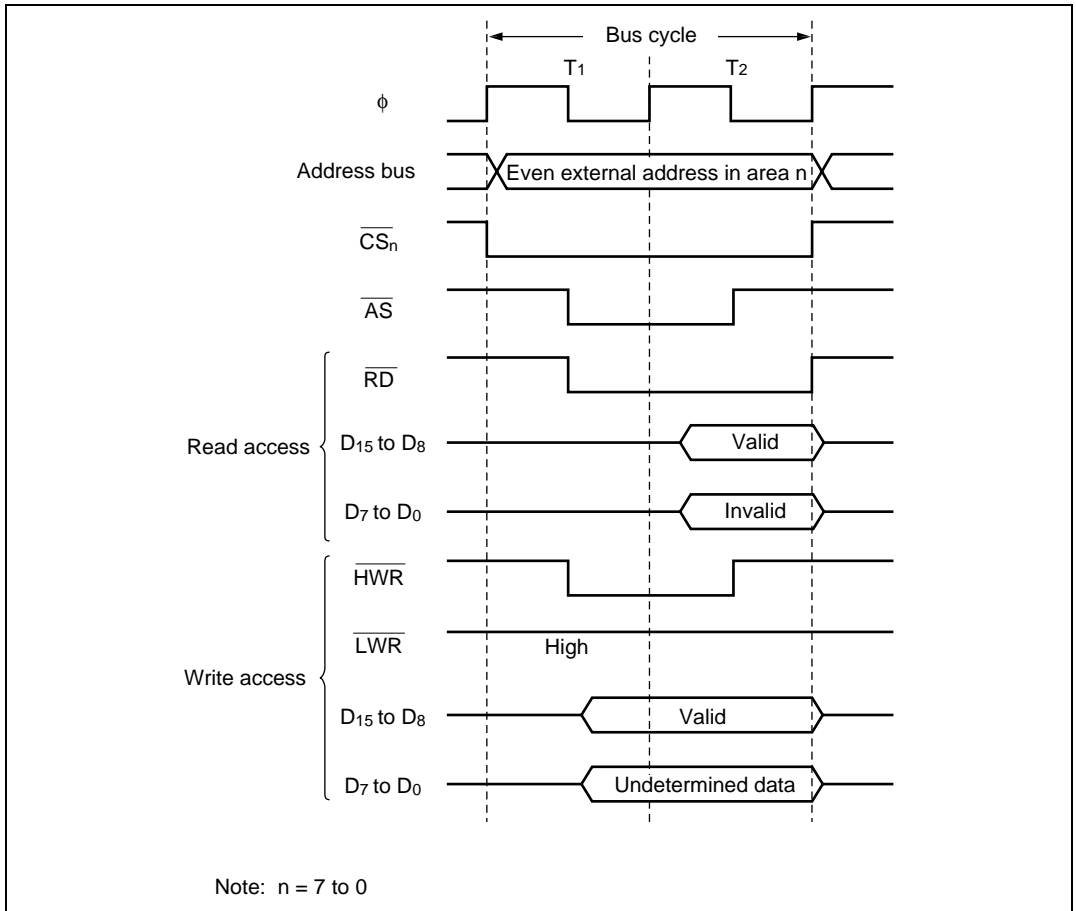
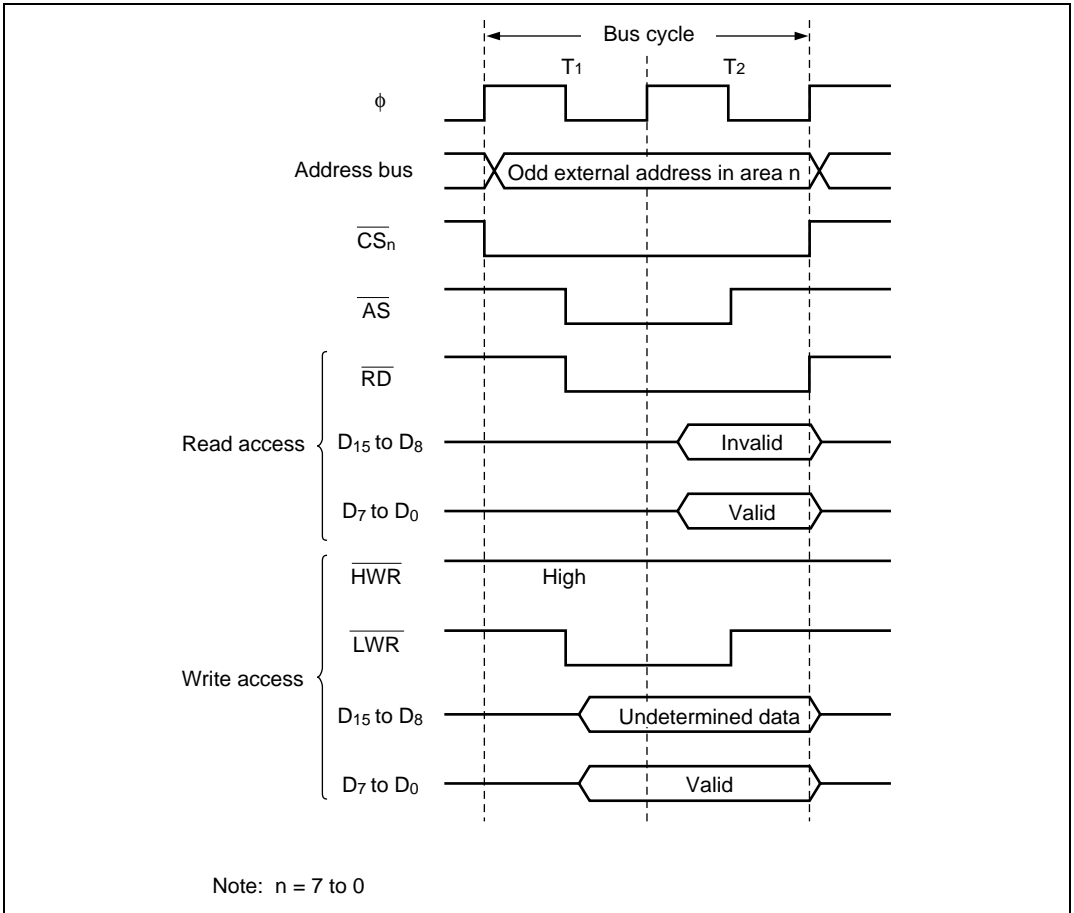

Figure 6.14 Bus Control Signal Timing for 16-Bit, Two-State-Access Area (1)
(Byte Access to Even Address)



**Figure 6.15 Bus Control Signal Timing for 16-Bit, Two-State-Access Area (2)
(Byte Access to Odd Address)**

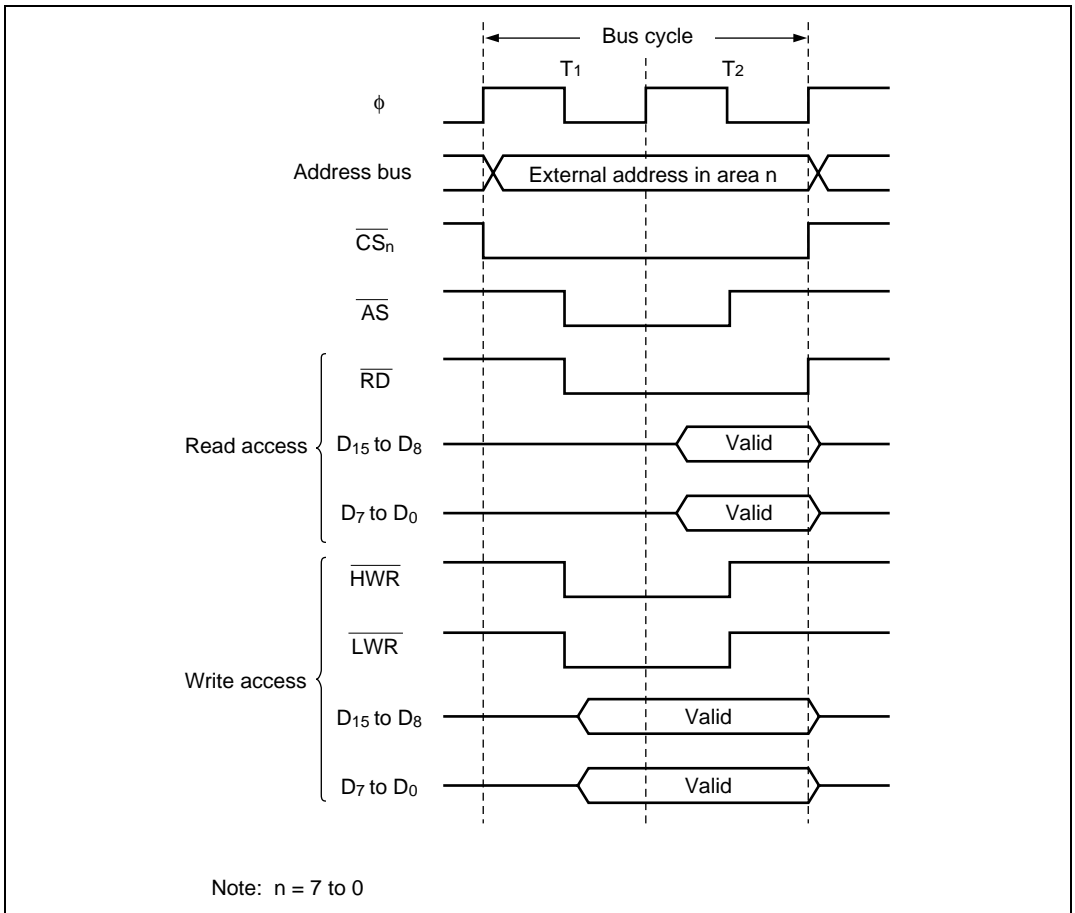

Figure 6.16 Bus Control Signal Timing for 16-Bit, Two-State-Access Area (3) (Word Access)

6.4.6 Wait Control

When accessing external space, the H8/3068F can extend the bus cycle by inserting one or more wait states (T_w). There are two ways of inserting wait states: (1) program wait insertion and (2) pin wait insertion using the \overline{WAIT} pin.

Program Wait Insertion: From 0 to 3 wait states can be inserted automatically between the T_2 state and T_3 state on an individual area basis in three-state access space, according to the settings of WCRH and WCRL.

Pin Wait Insertion: Setting the WAITE bit in BCR to 1 enables wait insertion by means of the $\overline{\text{WAIT}}$ pin. When external space is accessed in this state, a program wait is first inserted. If the $\overline{\text{WAIT}}$ pin is low at the falling edge of ϕ in the last T_2 or T_w state, another T_w state is inserted. If the $\overline{\text{WAIT}}$ pin is held low, T_w states are inserted until it goes high.

This is useful when inserting four or more T_w states, or when changing the number of T_w states for different external devices.

The WAITE bit setting applies to all areas. Pin waits cannot be inserted in DRAM space.

Figure 6.17 shows an example of the timing for insertion of one program wait state in 3-state space.

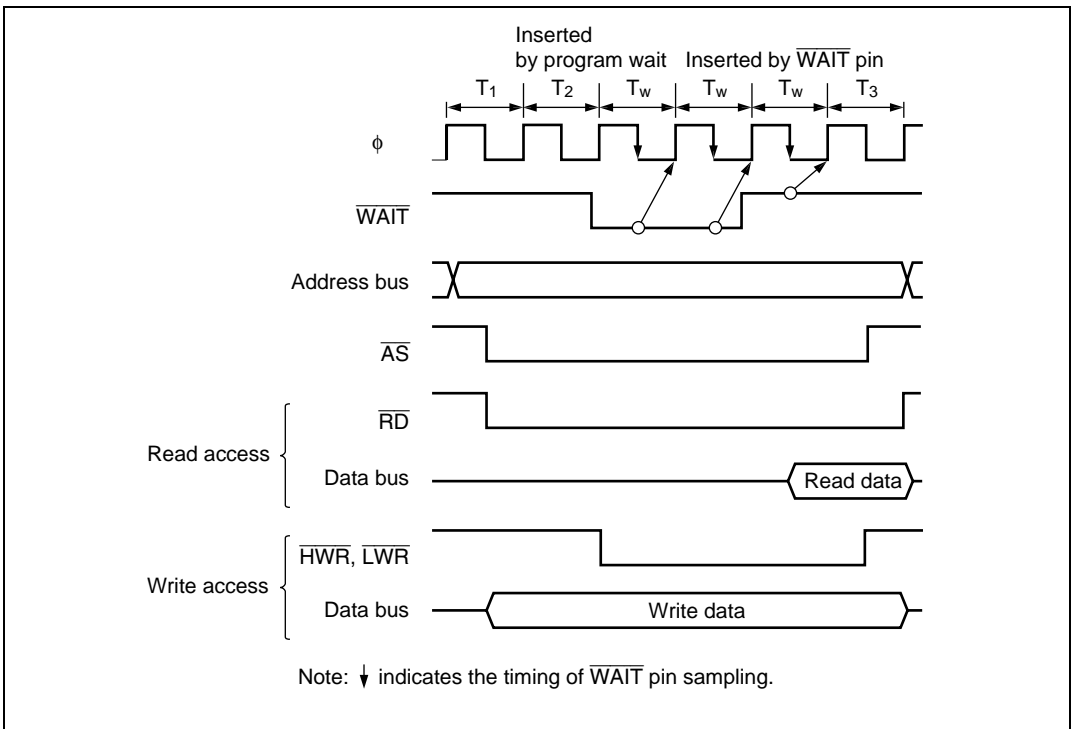

Figure 6.17 Example of Wait State Insertion Timing

6.5 DRAM Interface

6.5.1 Overview

The H8/3068F is provided with a DRAM interface with functions for DRAM control signal (\overline{RAS} , \overline{UCAS} , \overline{LCAS} , \overline{WE}) output, address multiplexing, and refreshing, that direct connection of DRAM. In the expanded modes, external address space areas 2 to 5 can be designated as DRAM space accessed via the DRAM interface. A data bus width of 8 or 16 bits can be selected for DRAM space by means of a setting in ABWCR. When a 16-bit data bus width is selected, CAS is used for byte access control. In the case of $\times 16$ -bit organization DRAM, therefore, the 2-CAS type can be connected. A fast page mode is supported in addition to the normal read and write access modes.

6.5.2 DRAM Space and \overline{RAS} Output Pin Settings

Designation of areas 2 to 5 as DRAM space, and selection of the \overline{RAS} output pin for each area designated as DRAM space, is performed by setting bits in DRCRA. Table 6.5 shows the correspondence between the settings of bits DRAS2 to DRAS0 and the selected DRAM space and \overline{RAS} output pin.

When an arbitrary value has been set in DRAS2 to DRAS0, a write of a different value other than 000 must not be performed.

Table 6.5 Settings of Bits DRAS2 to DRAS0 and Corresponding DRAM Space ($\overline{\text{RAS}}$ Output Pin)

DRAS2	DRAS1	DRAS0	Area 5	Area 4	Area 3	Area 2
0	0	0	Normal space	Normal space	Normal space	Normal space
		1	Normal space	Normal space	Normal space	DRAM space ($\overline{\text{CS}}_2$)
	1	0	Normal space	Normal space	DRAM space ($\overline{\text{CS}}_3$)	DRAM space ($\overline{\text{CS}}_2$)
		1	Normal space	Normal space	DRAM space ($\overline{\text{CS}}_2$)*	DRAM space ($\overline{\text{CS}}_2$)*
1	0	0	Normal space	DRAM space ($\overline{\text{CS}}_4$)	DRAM space ($\overline{\text{CS}}_3$)	DRAM space ($\overline{\text{CS}}_2$)
		1	DRAM space ($\overline{\text{CS}}_5$)	DRAM space ($\overline{\text{CS}}_4$)	DRAM space ($\overline{\text{CS}}_3$)	DRAM space ($\overline{\text{CS}}_2$)
	1	0	DRAM space ($\overline{\text{CS}}_4$)*	DRAM space ($\overline{\text{CS}}_4$)*	DRAM space ($\overline{\text{CS}}_2$)*	DRAM space ($\overline{\text{CS}}_2$)*
		1	DRAM space ($\overline{\text{CS}}_2$)*	DRAM space ($\overline{\text{CS}}_2$)*	DRAM space ($\overline{\text{CS}}_2$)*	DRAM space ($\overline{\text{CS}}_2$)*

Note: * A single $\overline{\text{CS}}_n$ pin serves as a common $\overline{\text{RAS}}$ output pin for a number of areas. Unused $\overline{\text{CS}}_n$ pins can be used as input/output ports.

6.5.3 Address Multiplexing

When DRAM space is accessed, the row address and column address are multiplexed. The address multiplexing method is selected with bits MXC1 and MXC0 in DRCRB according to the number of bits in the DRAM column address. Table 6.6 shows the correspondence between the settings of MXC1 and MXC0 and the address multiplexing method.

Table 6.6 Settings of Bits MXC1 and MXC0 and Address Multiplexing Method

	DRCRB		Column Address	Address Pins															
	MXC1	MXC0	Bits	A ₂₃ to A ₁₃	A ₁₂	A ₁₁	A ₁₀	A ₉	A ₈	A ₇	A ₆	A ₅	A ₄	A ₃	A ₂	A ₁	A ₀		
Row address	0	0	8 bits	A ₂₃ to A ₁₃	A ₁₂	A ₁₁	A ₁₀	A ₉	A ₈	A ₇	A ₆	A ₅	A ₄	A ₃	A ₂	A ₁	A ₀		
		1	9 bits	A ₂₃ to A ₁₃	A ₁₂	A ₂₀ * A ₁₉	A ₁₈	A ₁₇	A ₁₆	A ₁₅	A ₁₄	A ₁₃	A ₁₂	A ₁₁	A ₁₀	A ₉			
	1	0	10 bits	A ₂₃ to A ₁₃	A ₁₂	A ₁₁	A ₂₀ * A ₁₉	A ₁₈	A ₁₇	A ₁₆	A ₁₅	A ₁₄	A ₁₃	A ₁₂	A ₁₁	A ₁₀	A ₉		
		1	Illegal setting	—	—	—	—	—	—	—	—	—	—	—	—	—	—	—	
Column address	—	—	—	A ₂₃ to A ₁₃	A ₁₂	A ₁₁	A ₁₀	A ₉	A ₈	A ₇	A ₆	A ₅	A ₄	A ₃	A ₂	A ₁	A ₀		

Note: * Row address bit A₂₀ is not multiplexed in 1-Mbyte mode.

6.5.4 Data Bus

If the bit in ABWCR corresponding to an area designated as DRAM space is set to 1, that area is designated as 8-bit DRAM space; if the bit is cleared to 0, the area is designated as 16-bit DRAM space. In 16-bit DRAM space, × 16-bit organization DRAM can be connected directly.

In 8-bit DRAM space the upper half of the data bus, D₁₅ to D₈, is enabled, while in 16-bit DRAM space both the upper and lower halves of the data bus, D₁₅ to D₀, are enabled.

Access sizes and data alignment are the same as for the basic bus interface: see section 6.4.2, Data Size and Data Alignment.

6.5.5 Pins Used for DRAM Interface

Table 6.7 shows the pins used for DRAM interfacing and their functions.

Table 6.7 DRAM Interface Pins

Pin	With DRAM Designated	Name	I/O	Function
PB4	\overline{UCAS}	Upper column address strobe	Output	Upper column address strobe for DRAM space access (when CSEL = 0 in DRCRB)
PB5	\overline{LCAS}	Lower column address strobe	Output	Lower column address strobe for DRAM space access (when CSEL = 0 in DRCRB)
\overline{HWR}	\overline{UCAS}	Upper column address strobe	Output	Upper column address strobe for DRAM space access (when CSEL = 1 in DRCRB)
\overline{LWR}	\overline{LCAS}	Lower column address strobe	Output	Lower column address strobe for DRAM space access (when CSEL = 1 in DRCRB)
\overline{CS}_2	\overline{RAS}_2	Row address strobe 2	Output	Row address strobe for DRAM space access
\overline{CS}_3	\overline{RAS}_3	Row address strobe 3	Output	Row address strobe for DRAM space access
\overline{CS}_4	\overline{RAS}_4	Row address strobe 4	Output	Row address strobe for DRAM space access
\overline{CS}_5	\overline{RAS}_5	Row address strobe 5	Output	Row address strobe for DRAM space access
\overline{RD}	\overline{WE}	Write enable	Output	Write enable for DRAM space write access*
P80	\overline{RFSH}	Refresh	Output	Goes low in refresh cycle
A ₁₂ to A ₀	A ₁₂ to A ₀	Address	Output	Row address/column address multiplexed output
D ₁₅ to D ₀	D ₁₅ to D ₀	Data	I/O	Data input/output pins

Note: * Fixed high in a read access.

6.5.6 Basic Timing

Figure 6.18 shows the basic access timing for DRAM space. The basic DRAM access timing is four states: one precharge cycle (T_p) state, one row address output cycle (T_r) state, and two column address output cycle (T_{c1} , T_{c2}) states. Unlike the basic bus interface, the corresponding bits in ASTCR control only enabling or disabling of wait insertion between T_{c1} and T_{c2} , and do not affect the number of access states. When the corresponding bit in ASTCR is cleared to 0, wait states cannot be inserted between T_{c1} and T_{c2} in the DRAM access cycle.

If a DRAM read/write cycle is followed by an access cycle for an external area other than DRAM space when \overline{HWR} and \overline{LWR} are selected as the \overline{UCAS} and \overline{LCAS} output pins, an idle cycle (T_i) is inserted unconditionally immediately after the DRAM access cycle. See section 6.9, Idle Cycle, for details.

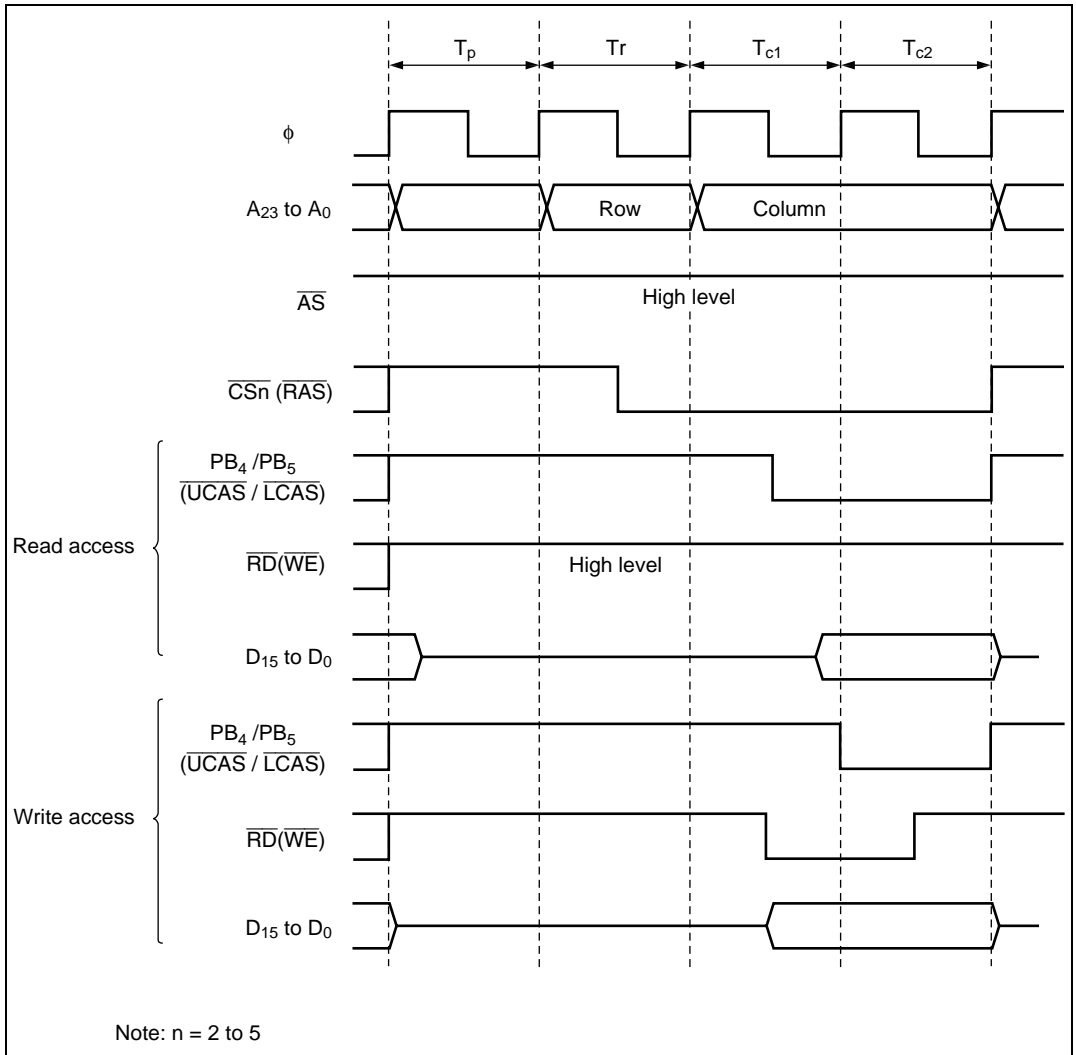

Figure 6.18 Basic Access Timing (CSEL = 0 in DRCRB)

6.5.7 Precharge State Control

In the H8/3068F, provision is made for the DRAM RAS precharge time by always inserting one RAS precharge state (T_p) when DRAM space is accessed. This can be changed to two T_p states by setting the TPC bit to 1 in DRCRB. The optimum number of T_p cycles should be set according to the DRAM connected and the operating frequency of the H8/3068F chip. Figure 6.19 shows the timing when two T_p states are inserted.

When the TCP bit is set to 1, two T_p states are also used for CAS-before-RAS refresh cycles.

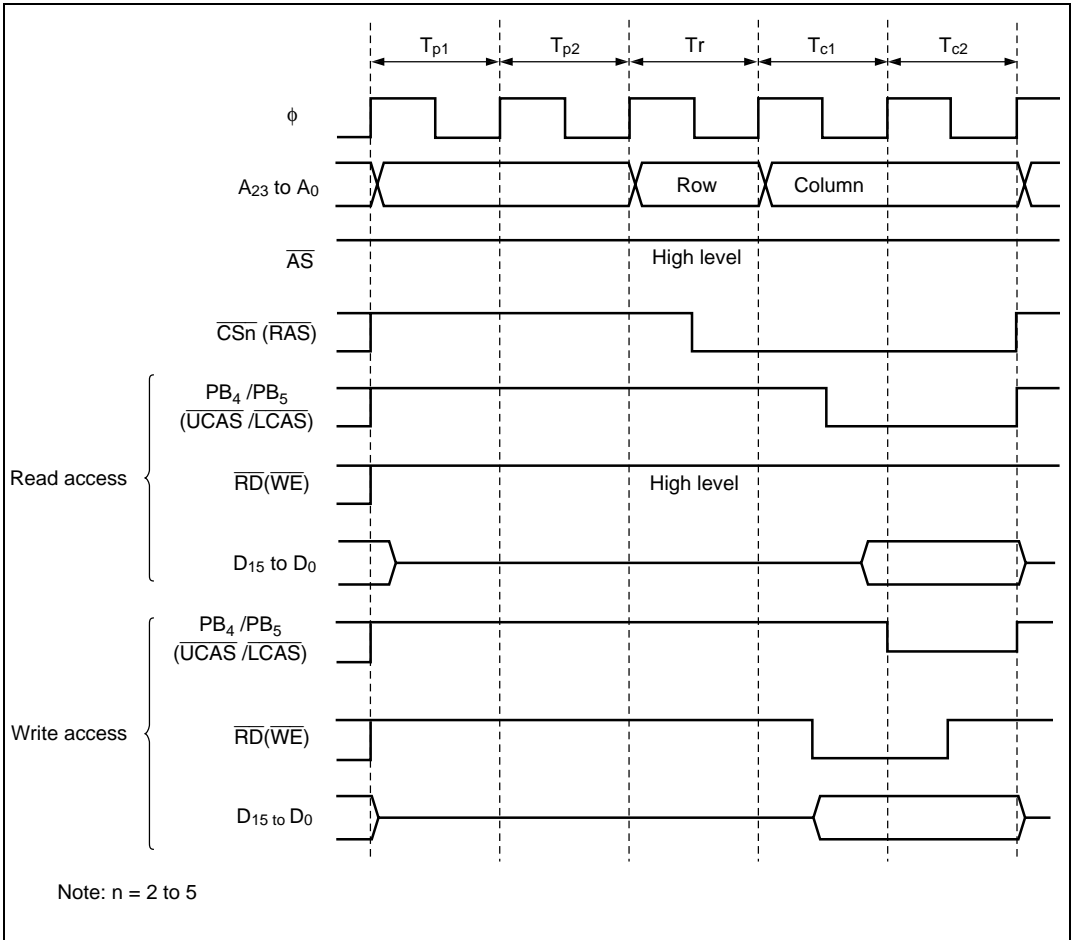

Figure 6.19 Timing with Two Precharge States (CSEL = 0 in DRCRB)

6.5.8 Wait Control

In a DRAM access cycle, wait states can be inserted (1) between the T_r state and T_{c1} state, and (2) between the T_{c1} state and T_{c2} state.

Insertion of T_{rw} Wait State between T_r and T_{c1} : One T_{rw} state can be inserted between T_r and T_{c1} by setting the RCW bit to 1 in DRCRB.

Insertion of T_w Wait State(s) between T_{c1} and T_{c2} : When the bit in ASTCR corresponding to an area designated as DRAM space is set to 1, from 0 to 3 wait states can be inserted between the T_{c1} state and T_{c2} state by means of settings in WCRH and WCRL.

Figure 6.20 shows an example of the timing for wait state insertion.

The settings of the RCW bit in DRCRB and of ASTCR, WCRH, and WCRL do not affect refresh cycles. Wait states cannot be inserted in a DRAM space access cycle by means of the $\overline{\text{WAIT}}$ pin.

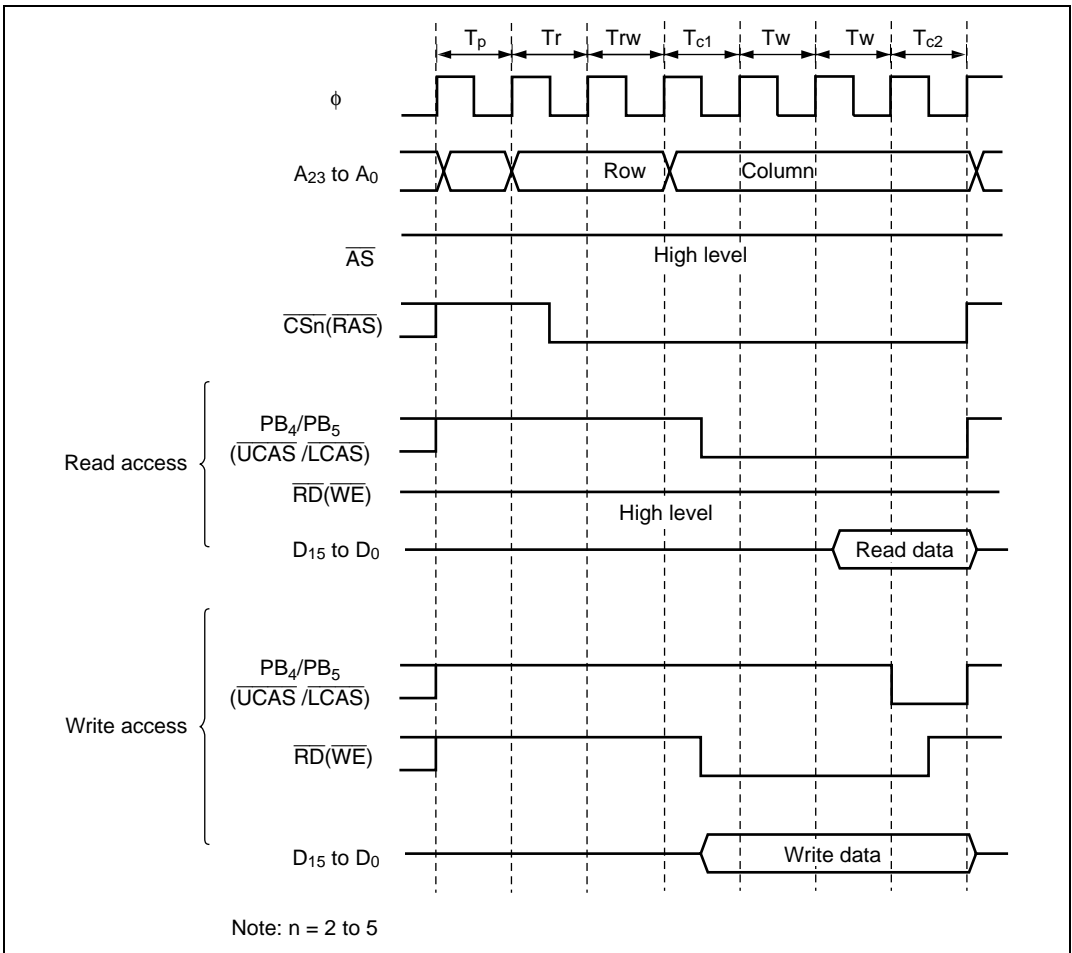

Figure 6.20 Example of Wait State Insertion Timing (CSEL = 0)

6.5.9 Byte Access Control and \overline{CAS} Output Pin

When an access is made to DRAM space designated as a 16-bit-access area in ABWCR, column address strobes (\overline{UCAS} and \overline{LCAS}) corresponding to the upper and lower halves of the external data bus are output. In the case of $\times 16$ -bit organization DRAM, the 2-CAS type can be connected.

Either PB4 and PB5, or \overline{HWR} and \overline{LWR} , can be used as the \overline{UCAS} and \overline{LCAS} output pins, the selection being made with the CSEL bit in DRCRB. Table 6.8 shows the CSEL bit settings and corresponding output pin selections.

When an access is made to DRAM space designated as an 8-bit-access area in ABWCR, only \overline{UCAS} is output. When the entire DRAM space is designated as 8-bit-access space and $CSEL = 0$, PB_5 can be used as an input/output port.

Note that \overline{RAS} down mode cannot be used when a device other than DRAM is connected to external space and \overline{HWR} and \overline{LWR} are used as write strobes. In this case, also, an idle cycle (T_i) is always inserted when an external access to other than DRAM space occurs after a DRAM space access. For details, see section 6.9, Idle Cycle.

Table 6.8 CSEL Settings and \overline{UCAS} and \overline{LCAS} Output Pins

CSEL	\overline{UCAS}	\overline{LCAS}
0	PB_4	PB_5
1	\overline{HWR}	\overline{LWR}

Figure 6.21 shows the control timing.

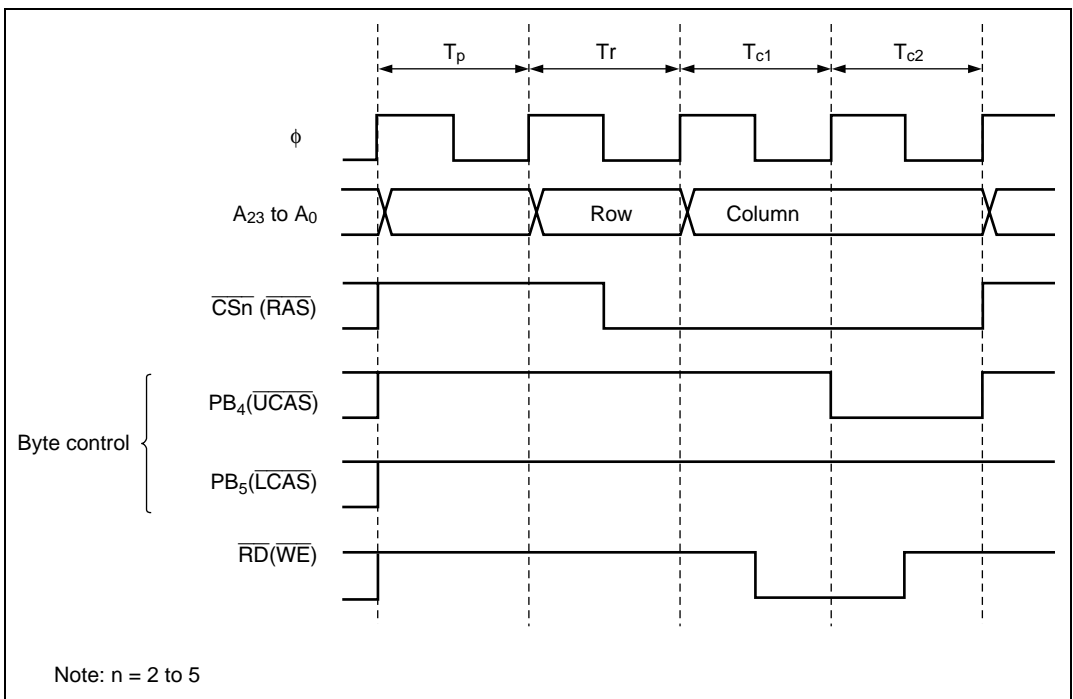

Figure 6.21 Control Timing (Upper-Byte Write Access When $CSEL = 0$)

6.5.10 Burst Operation

With DRAM, in addition to full access (normal access) in which data is accessed by outputting a row address for each access, a fast page mode is also provided which can be used when making a number of consecutive accesses to the same row address. This mode enables fast (burst) access of data by simply changing the column address after the row address has been output. Burst access can be selected by setting the BE bit to 1 in DRCRA.

Burst Access (Fast Page Mode) Operation Timing: Figure 6.22 shows the operation timing for burst access. When there are consecutive access cycles for DRAM space, the column address and $\overline{\text{CAS}}$ signal output cycles (two states) continue as long as the row address is the same for consecutive access cycles. In burst access, too, the bus cycle can be extended by inserting wait states between T_{c1} and T_{c2} . The wait state insertion method and timing are the same as for full access: see section 6.5.8, Wait Control, for details.

The row address used for the comparison is determined by the bus width of the relevant area set in bits MXC1 and MXC0 in BRRCRB, and in ABWCR. Table 6.9 shows the compared row addresses corresponding to the various settings of bits MXC1 and MXC0, and ABWCR.

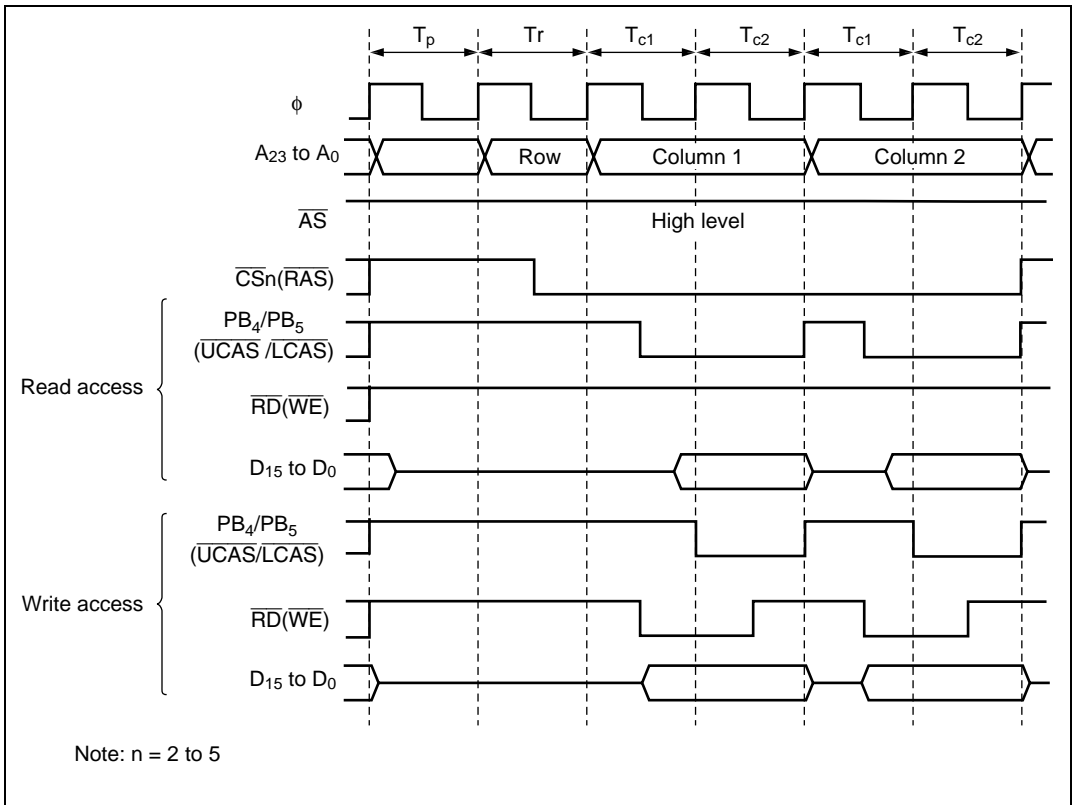

Figure 6.22 Operation Timing in Fast Page Mode

Table 6.9 Correspondence between Settings of MXC1 and MXC0 Bits and ABWCR, and Row Address Compared in Burst Access

Operating Mode	DRCRB		ABWCR		Compared Row Address
	MXC1	MXC0	ABWn	Bus Width	
Modes 1 and 2 (1-Mbyte)	0	0	0	16 bits	A19 to A9
			1	8 bits	A19 to A8
	1	0	0	16 bits	A19 to A10
			1	8 bits	A19 to A9
	1	0	0	16 bits	A19 to A11
			1	8 bits	A19 to A10
1	—	—	—	Illegal setting	
Modes 3, 4, and 5 (16-Mbyte)	0	0	0	16 bits	A23 to A9
			1	8 bits	A23 to A8
	1	0	0	16 bits	A23 to A10
			1	8 bits	A23 to A9
	1	0	0	16 bits	A23 to A11
			1	8 bits	A23 to A10
1	—	—	—	Illegal setting	

Note: n = 2 to 5

RAS Down Mode and RAS Up Mode: With DRAM provided with fast page mode, as long as accesses are to the same row address, burst operation can be continued without interruption even if accesses are not consecutive by holding the $\overline{\text{RAS}}$ signal low.

- RAS Down Mode

To select RAS down mode, set the BE and RDM bits to 1 in DRCRA. If access to DRAM space is interrupted and another space is accessed, the $\overline{\text{RAS}}$ signal is held low during the access to the other space, and burst access is performed if the row address of the next DRAM space access is the same as the row address of the previous DRAM space access. Figure 6.23 shows an example of the timing in RAS down mode.

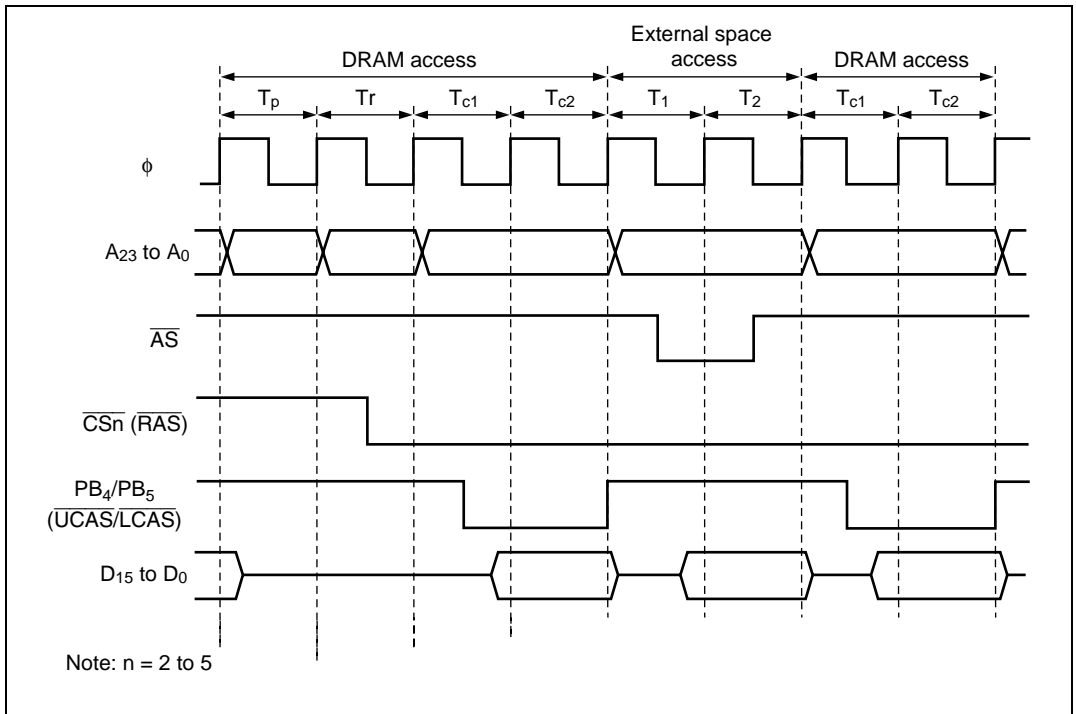

Figure 6.23 Example of Operation Timing in RAS Down Mode (CSEL = 0)

When RAS down mode is selected, the conditions for an asserted \overline{RASn} signal to return to the high level are as shown below. The timing in these cases is shown in figure 6.24.

- When DRAM space with a different row address is accessed
- Immediately before a CAS-before-RAS refresh cycle
- When the BE bit or RDM bit is cleared to 0 in DRCRA
- Immediately before release of the external bus

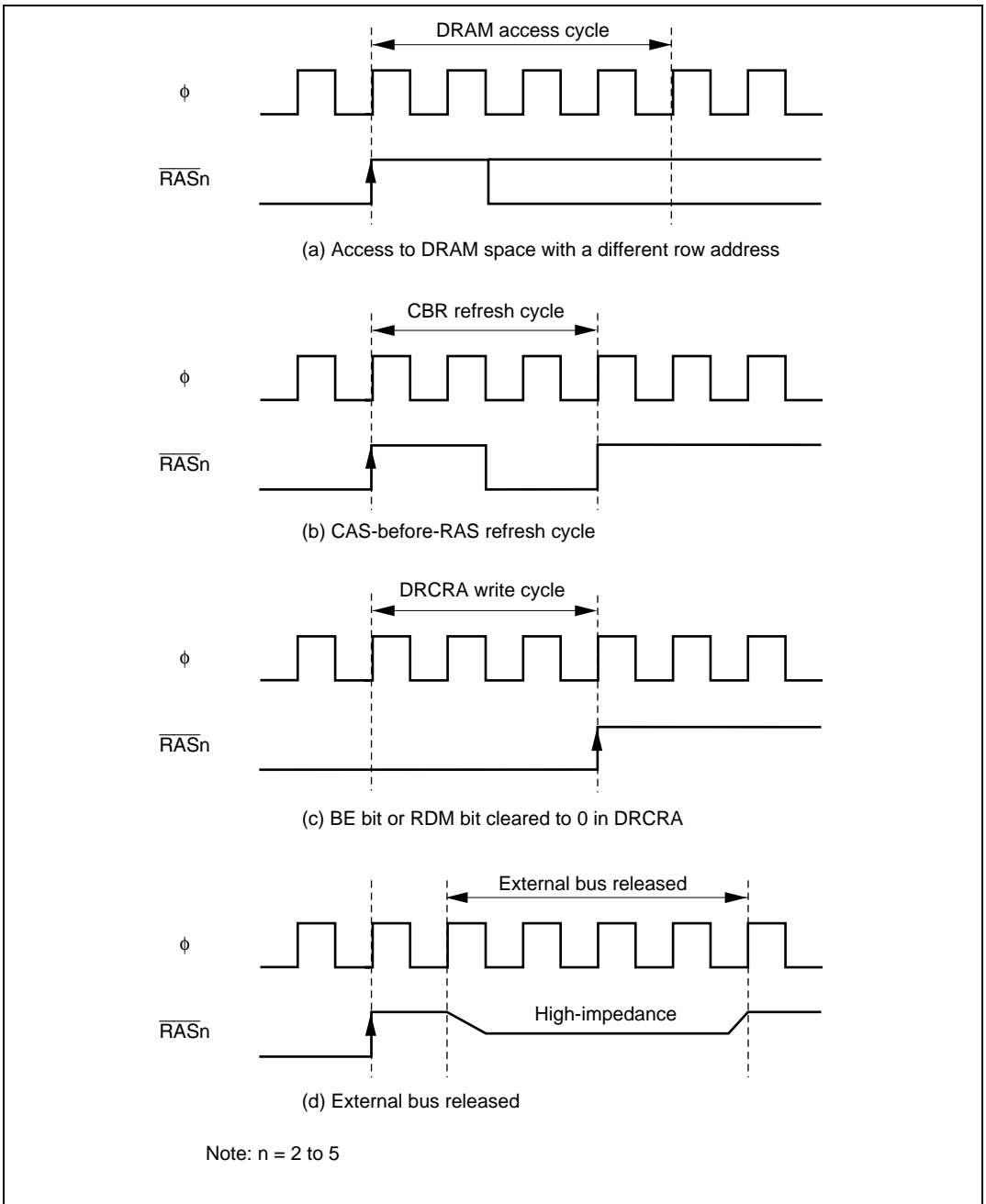

Figure 6.24 $\overline{\text{RASn}}$ Negation Timing when RAS Down Mode is Selected

When RAS down mode is selected, the CAS-before-RAS refresh function provided with this DRAM interface must always be used as the DRAM refreshing method. When a refresh operation is performed, the $\overline{\text{RAS}}$ signal goes high immediately beforehand. The refresh interval setting must be made so that the maximum DRAM $\overline{\text{RAS}}$ pulse width specification is observed.

When the self-refresh function is used, the RDM bit must be cleared to 0, and RAS up mode selected, before executing a SLEEP instruction in order to enter software standby mode. Select RAS down mode again after exiting software standby mode.

Note that RAS down mode cannot be used when $\overline{\text{HWR}}$ and $\overline{\text{LWR}}$ are selected for $\overline{\text{UCAS}}$ and $\overline{\text{LCAS}}$, a device other than DRAM is connected to external space, and $\overline{\text{HWR}}$ and $\overline{\text{LWR}}$ are used as write strobes.

- RAS Up Mode

To select RAS up mode, clear the RDM bit to 0 in DRCRA. Each time access to DRAM space is interrupted and another space is accessed, the $\overline{\text{RAS}}$ signal returns to the high level. Burst operation is only performed if DRAM space is continuous. Figure 6.25 shows an example of the timing in RAS up mode.

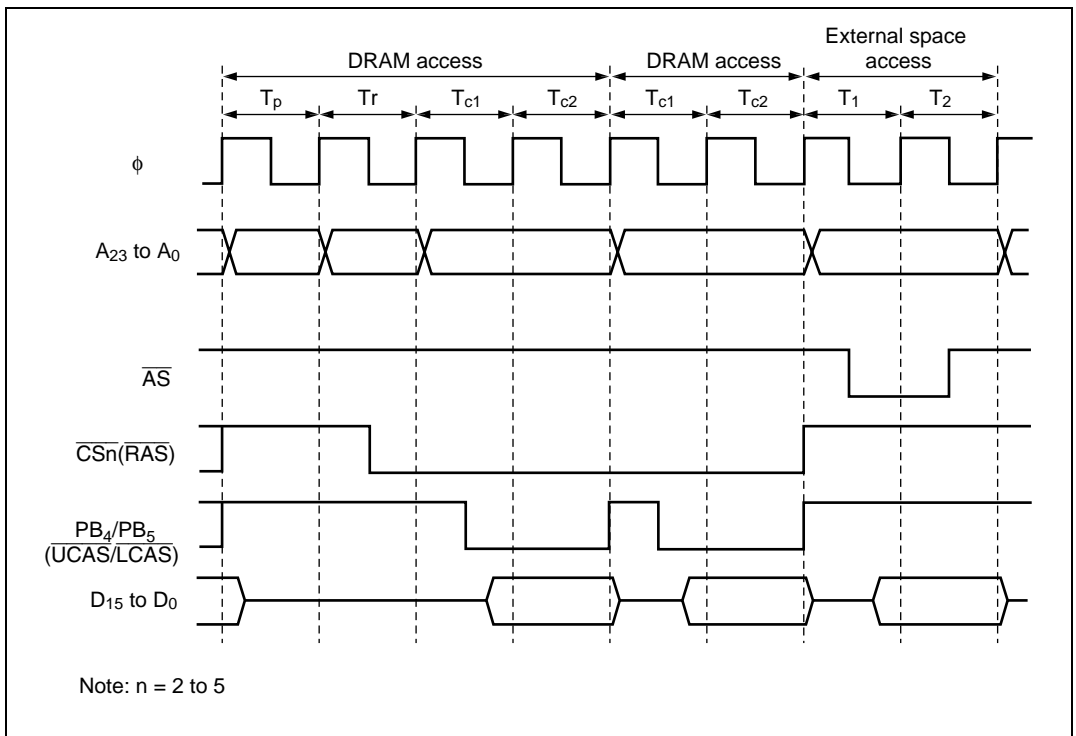

Figure 6.25 Example of Operation Timing in RAS Up Mode

6.5.11 Refresh Control

The H8/3068F is provided with a CAS-before-RAS (CBR) function and self-refresh function as DRAM refresh control functions.

CAS-Before-RAS (CBR) Refreshing: To select CBR refreshing, set the RCYCE bit to 1 in DRCRB.

With CBR refreshing, RTCNT counts up using the input clock selected by bits CKS2 to CKS0 in RTMCSR, and a refresh request is generated when the count matches the value set in RTCOR (compare match). At the same time, RTCNT is reset and starts counting up again from H'00. Refreshing is thus repeated at fixed intervals determined by RTCOR and bits CKS2 to CKS0. A refresh cycle is executed after this refresh request has been accepted and the DRAM interface has acquired the bus. Set a value in bits CKS2 to CKS0 in RTCOR that will meet the refresh interval specification for the DRAM used. When RAS down mode is used, set the refresh interval so that the maximum $\overline{\text{RAS}}$ pulse width specification is met.

RTCNT starts counting up when bits CKS2 to CKS0 are set. RTCNT and RTCOR settings should therefore be completed before setting bits CKS2 to CKS0.

Also note that a repeat refresh request generated during a bus request, or a refresh request during refresh cycle execution, will be ignored.

RTCNT operation is shown in figure 6.26, compare match timing in figure 6.27, and CBR refresh timing in figures 6.28 and 6.29.

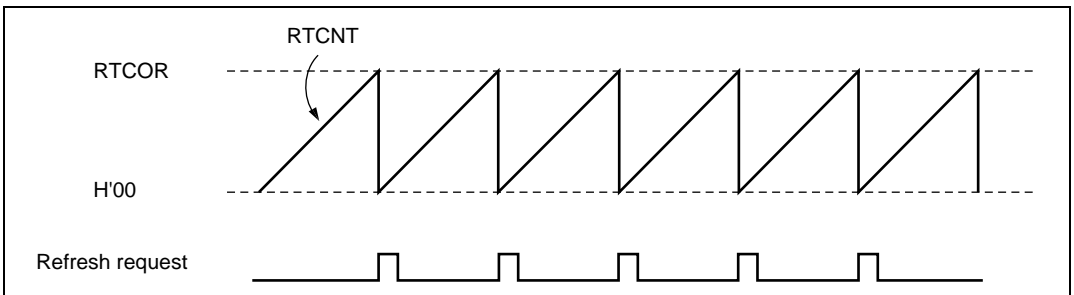

Figure 6.26 RTCNT Operation

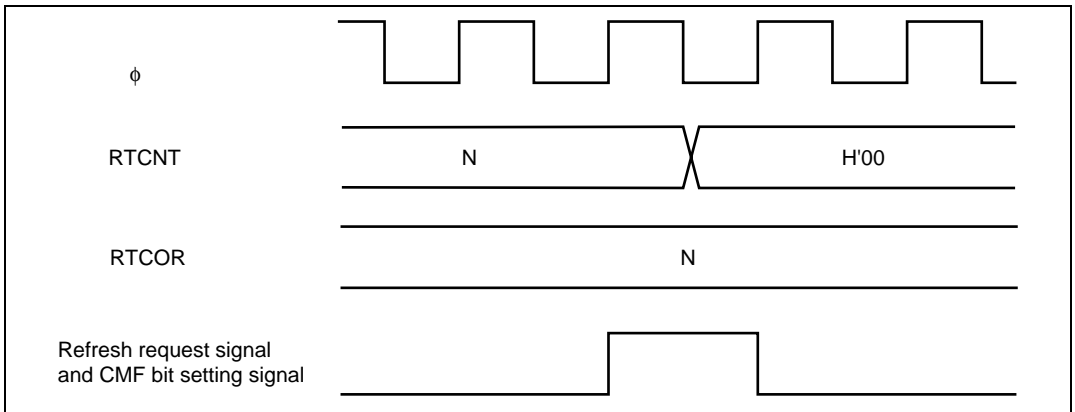
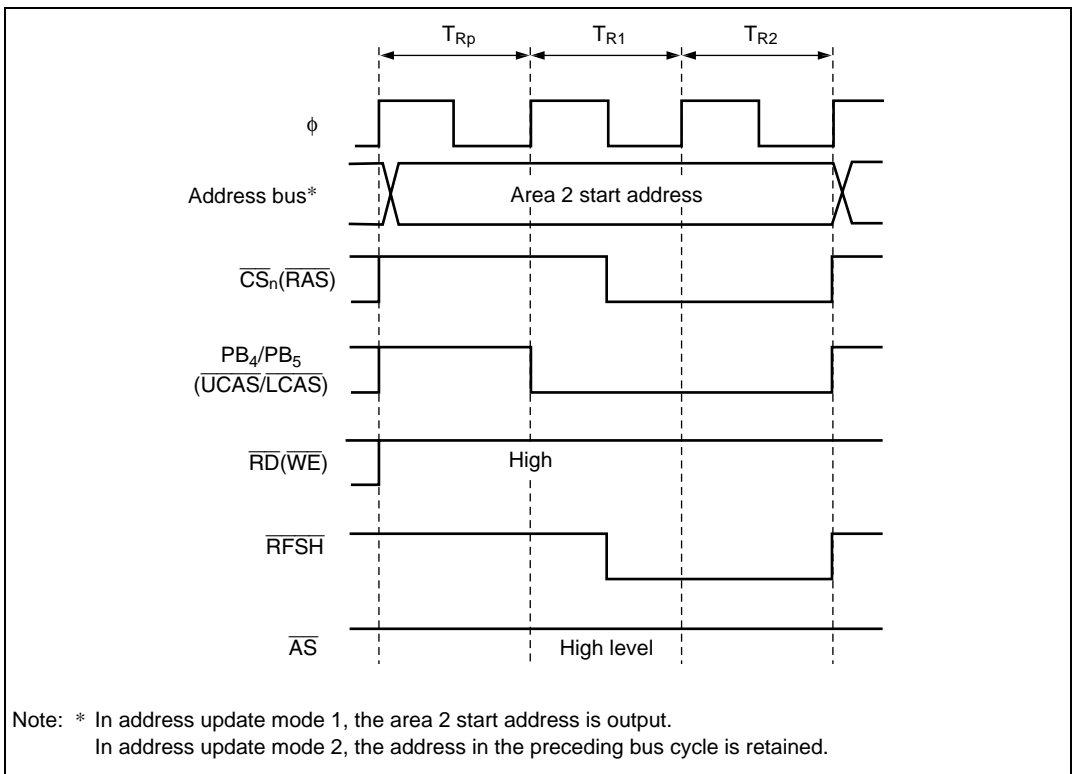

Figure 6.27 Compare Match Timing



Note: * In address update mode 1, the area 2 start address is output.
In address update mode 2, the address in the preceding bus cycle is retained.

Figure 6.28 CBR Refresh Timing (CSEL = 0, TPC = 0, RLW = 0)

The basic CBS refresh cycle timing comprises three states: one RAS precharge cycle (T_{Rp}) state, and two RAS output cycle (T_{R1} , T_{R2}) states. Either one or two states can be selected for the RAS

precharge cycle. When the TPC bit is set to 1 in DRCRB, $\overline{\text{RAS}}$ signal output is delayed by one cycle. This does not affect the timing of $\overline{\text{UCAS}}$ and $\overline{\text{LCAS}}$ output.

Use the RLW bit in DRCRB to adjust the $\overline{\text{RAS}}$ signal width. A single refresh wait state (T_{RW}) can be inserted between the T_{R1} state and T_{R2} state by setting the RLW bit to 1.

The RLW bit setting is valid only for CBR refresh cycles, and does not affect DRAM read/write cycles. The number of states in the CBR refresh cycle is not affected by the settings in ASTCR, WCRH, or WCRL, or by the state of the $\overline{\text{WAIT}}$ pin.

Figure 6.29 shows the timing when the TPC bit and RLW bit are both set to 1.

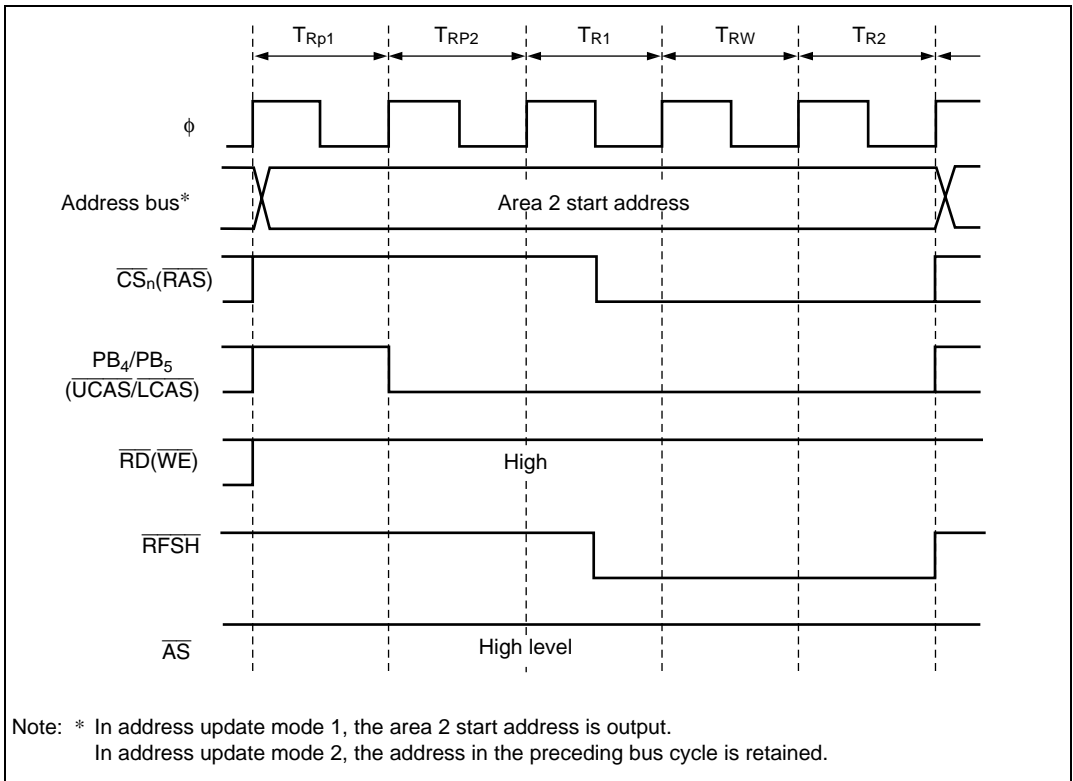

Figure 6.29 CBR Refresh Timing (CSEL = 0, TPC = 1, RLW = 1)

DRAM must be refreshed immediately after powering on in order to stabilize its internal state. When using the H8/3068F CAS-before-RAS refresh function, therefore, a DRAM stabilization period should be provided by means of interrupts by another timer module, or by counting the

number of times bit 7 (CMF) of RTMCSR is set, for instance, immediately after bits DRAS2 to DRAS0 have been set in DRCRA.

Self-Refreshing: A self-refresh mode (battery backup mode) is provided for DRAM as a kind of standby mode. In this mode, refresh timing and refresh addresses are generated within the DRAM. The H8/3068F has a function that places the DRAM in self-refresh mode when the chip enters software standby mode.

To use the self-refresh function, set the SRFMD bit to 1 in DRCRA. When a SLEEP instruction is subsequently executed in order to enter software standby mode, the $\overline{\text{CAS}}$ and $\overline{\text{RAS}}$ signals are output and the DRAM enters self-refresh mode, as shown in figure 6.30.

When the chip exits software standby mode, $\overline{\text{CAS}}$ and $\overline{\text{RAS}}$ outputs go high.

The following conditions must be observed when the self-refresh function is used:

- When burst access is selected, RAS up mode must be selected before executing a SLEEP instruction in order to enter software standby mode. Therefore, if RAS down mode has been selected, the RDM bit in DRCRA must be cleared to 0 and RAS up mode selected before executing the SLEEP instruction. Select RAS down mode again after exiting software standby mode.
- The instruction immediately following a SLEEP instruction must not be located in an area designated as DRAM space.

The self-refresh function will not work properly unless the above conditions are observed.

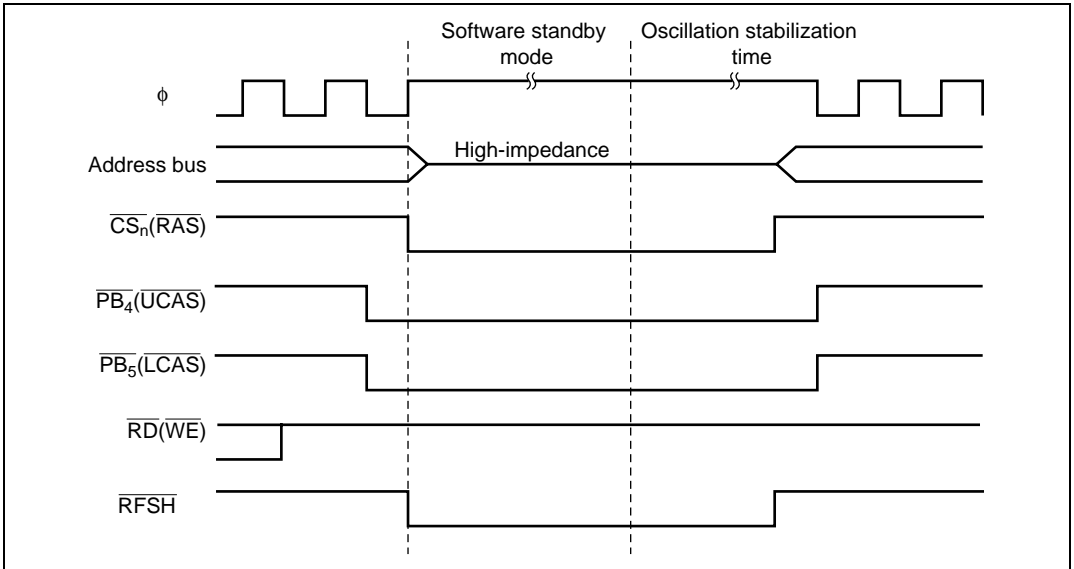

Figure 6.30 Self-Refresh Timing (CSEL = 0)

Refresh Signal (\overline{RFSH}): A refresh signal (\overline{RFSH}) that transmits a refresh cycle off-chip can be output by setting the RFSHE bit to 1 in DRCRA. \overline{RFSH} output timing is shown in figures 6.28, 6.29, and 6.30.

6.5.12 Examples of Use

Examples of DRAM connection and program setup procedures are shown below. When the DRAM interface is used, check the DRAM device characteristics and choose the most appropriate method of use for that device.

Connection Examples

- Figure 6.31 shows typical interconnections when using two 2-CAS type 16-Mbit DRAMs using a $\times 16$ -bit organization, and the corresponding address map. The DRAMs used in this example are of the 10-bit row address \times 10-bit column address type. Up to four DRAMs can be connected by designating areas 2 to 5 as DRAM space.

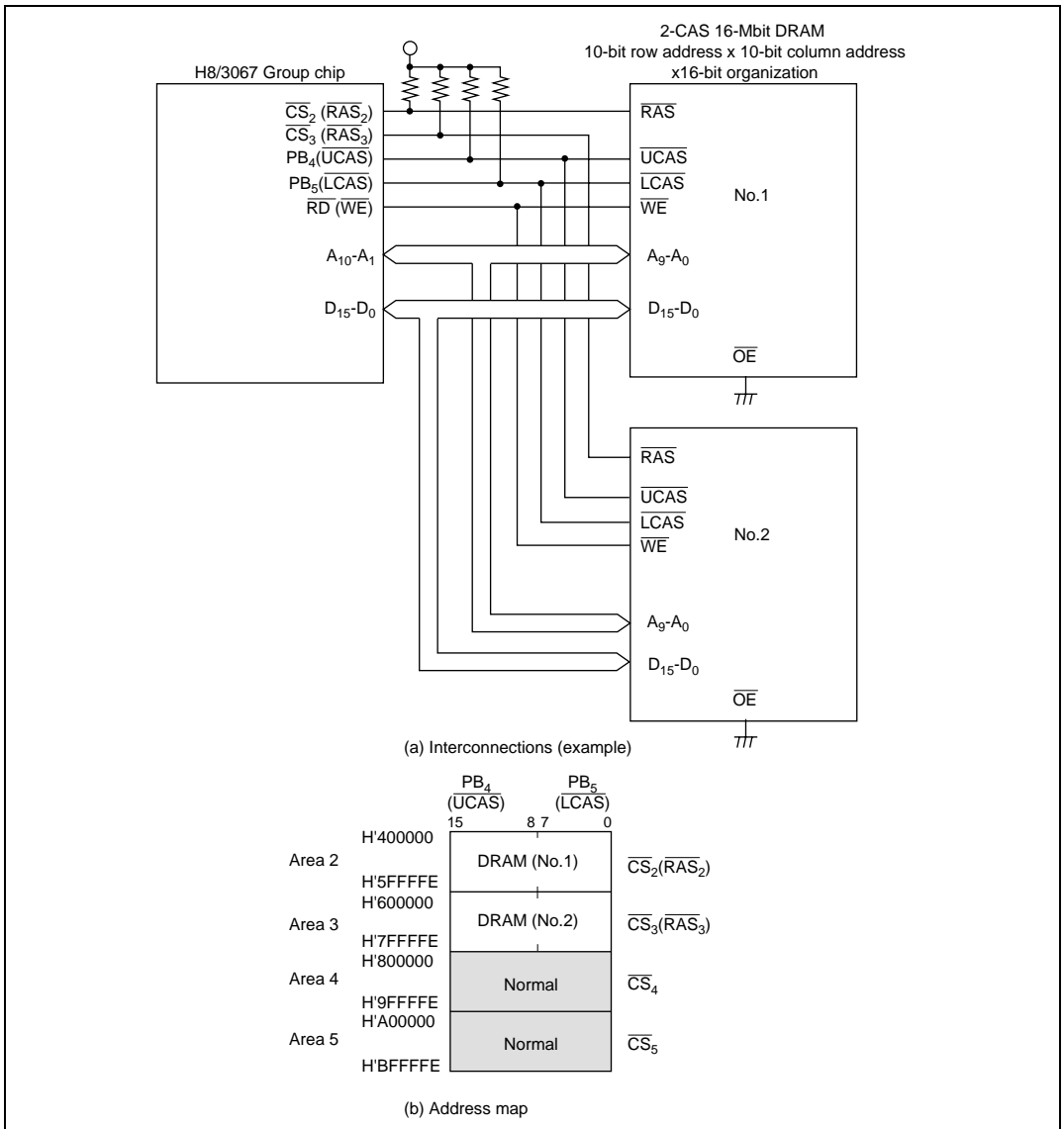

Figure 6.31 Interconnections and Address Map for 2-CAS 16-Mbit DRAMs with \times 16-Bit Organization

- Figure 6.32 shows typical interconnections when using two 16-Mbit DRAMs using a \times 8-bit organization, and the corresponding address map. The DRAMs used in this example are of the 11-bit row address \times 10-bit column address type. The \overline{CS}_2 pin is used as the common \overline{RAS} output pin for areas 2 and 3. When the DRAM address space spans a number of contiguous

areas, as in this example, the appropriate setting of bits DRAS2 to DRAS0 enables a single $\overline{\text{CS}}$ pin to be used as the common $\overline{\text{RAS}}$ output pin for a number of areas, and makes it possible to directly connect large-capacity DRAM with address space that spans a maximum of four areas. Any unused $\overline{\text{CS}}$ pins (in this example, the $\overline{\text{CS}}_3$ pin) can be used as input/output ports.

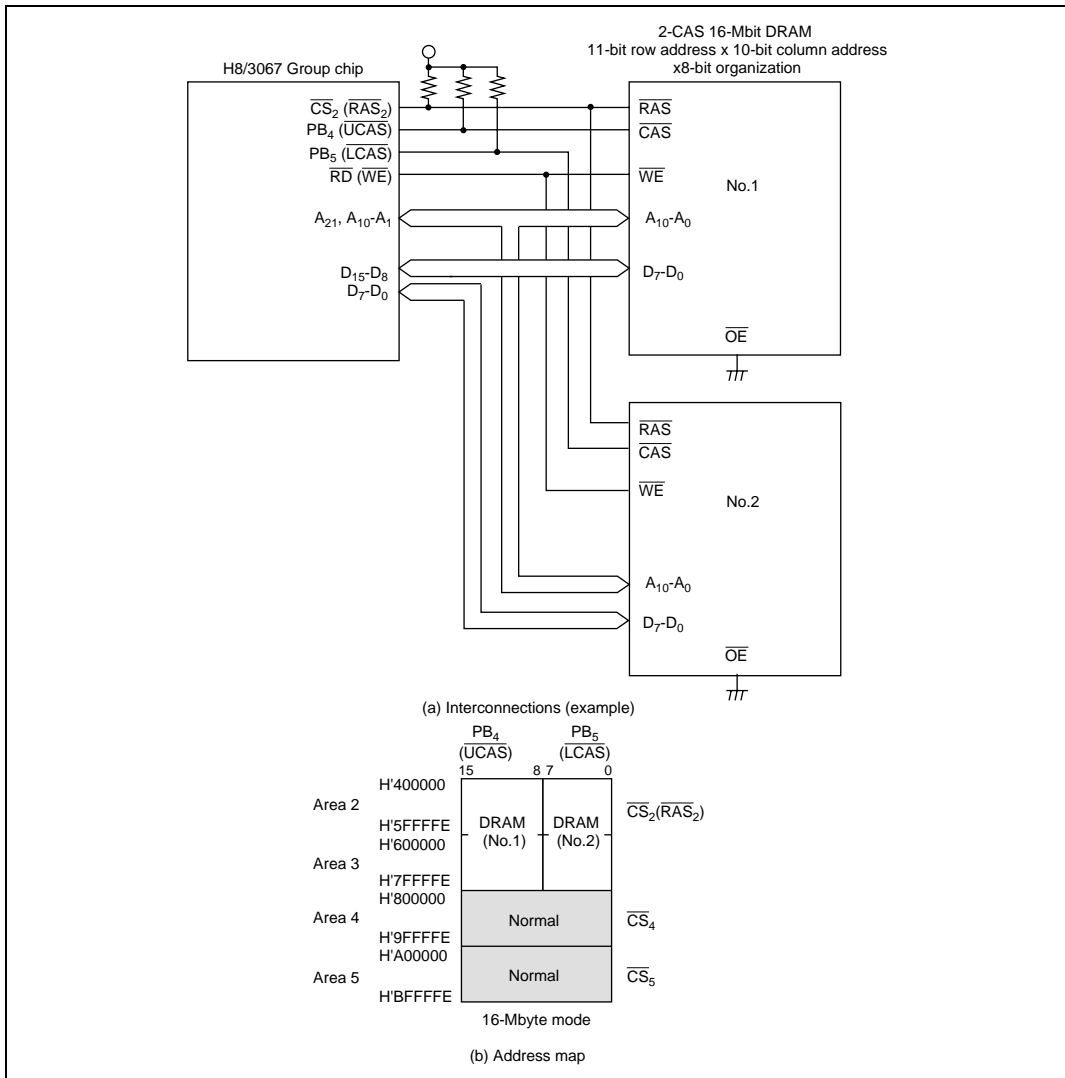

Figure 6.32 Interconnections and Address Map for 16-Mbit DRAMs with $\times 8$ -Bit Organization

- Figure 6.33 shows typical interconnections when using two 4-Mbit DRAMs, and the corresponding address map. The DRAMs used in this example are of the 9-bit row address \times 10-bit column address type. In this example, upper address decoding allows multiple DRAMs to be connected to a single area. The $\overline{\text{RFSH}}$ pin is used in this case, since both DRAMs must be refreshed simultaneously. However, note that RAS down mode cannot be used in this interconnection example.

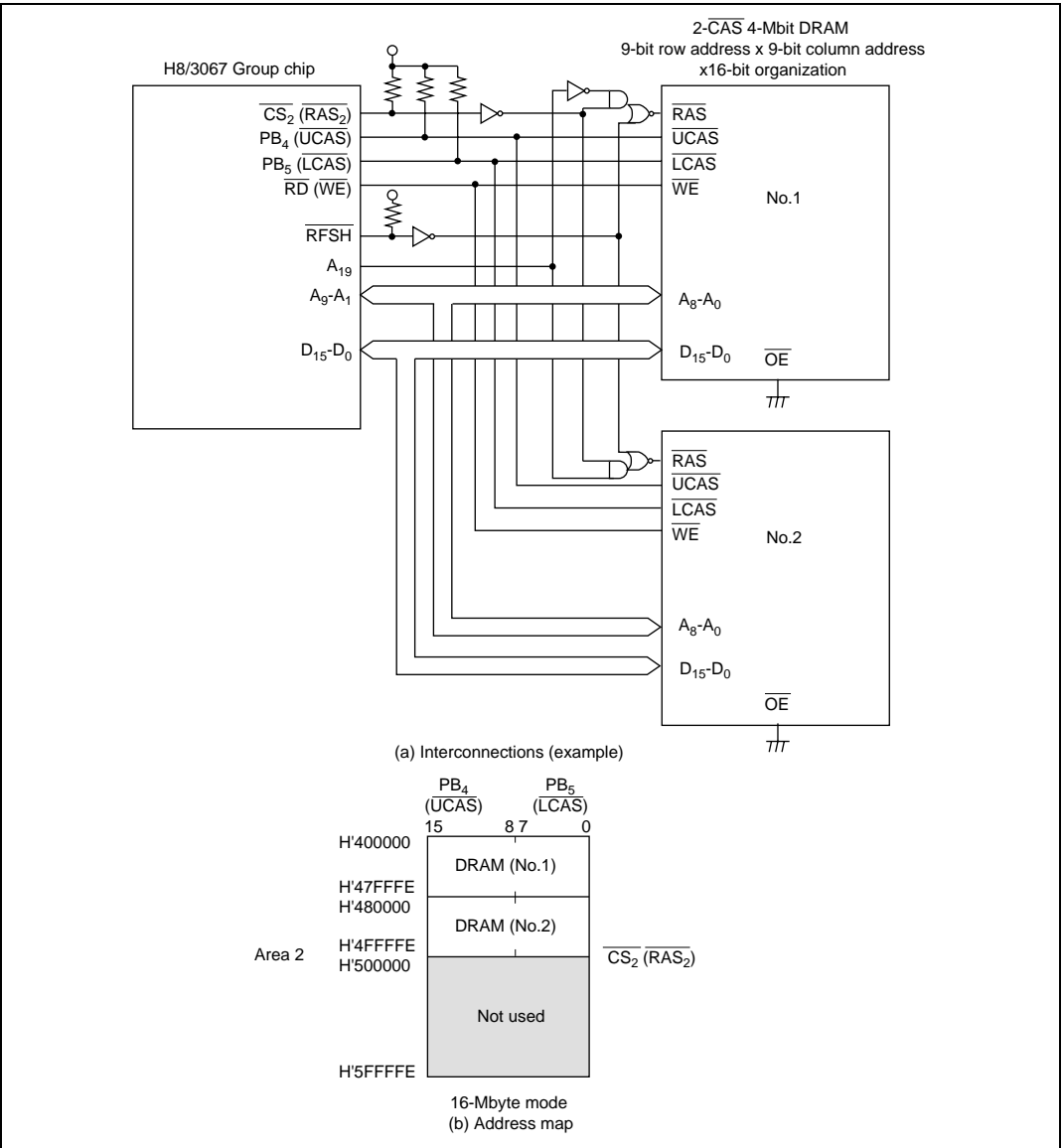

Figure 6.33 Interconnections and Address Map for 2-CAS 4-Mbit DRAMs with $\times 16$ -Bit Organization

Example of Program Setup Procedure: Figure 6.34 shows an example of the program setup procedure.

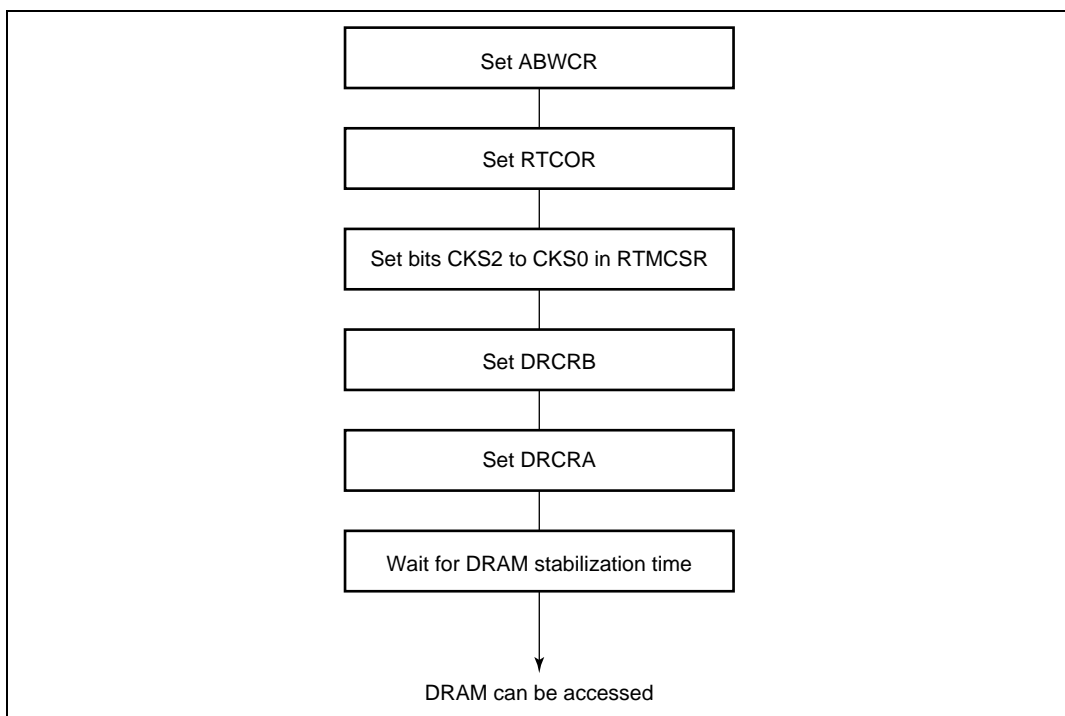

Figure 6.34 Example of Setup Procedure when Using DRAM Interface

6.5.13 Usage Notes

Note the following points when using the DRAM refresh function.

- Refresh cycles will not be executed when the external bus released state, software standby mode, or a bus cycle is extended by means of wait state insertion. Refreshing must therefore be performed by other means in these cases.
- If a refresh request is generated internally while the external bus is released, the first request is retained and a single refresh cycle will be executed after the bus-released state is cleared. Figure 6.35 shows the bus cycle in this case.
- When a bus cycle is extended by means of wait state insertion, the first request is retained in the same way as when the external bus has been released.

- In the event of contention with a bus request from an external bus master when a transition is made to software standby mode, the $\overline{\text{BACK}}$ and strobe states may be indeterminate after the transition to software standby mode (see figure 6.36).

When software standby mode is used, the BRLE bit should be cleared to 0 in BRCR before executing the SLEEP instruction.

Similar contention in a transition to self-refresh mode may prevent dependable strobe waveform output. This can also be avoided by clearing the BRLW bit to 0 in BRCR.

- Immediately after self-refreshing is cleared, external bus release is possible during a given period until the start of a CPU cycle. Attention must be paid to the $\overline{\text{RAS}}$ state to ensure that the specification for the $\overline{\text{RAS}}$ precharge time immediately after self-refreshing is met.

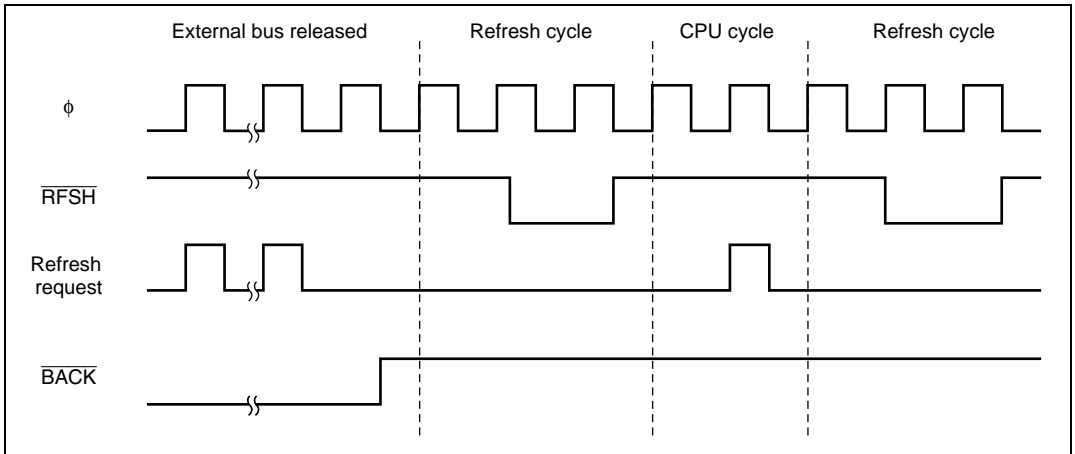

Figure 6.35 Bus-Released State and Refresh Cycles

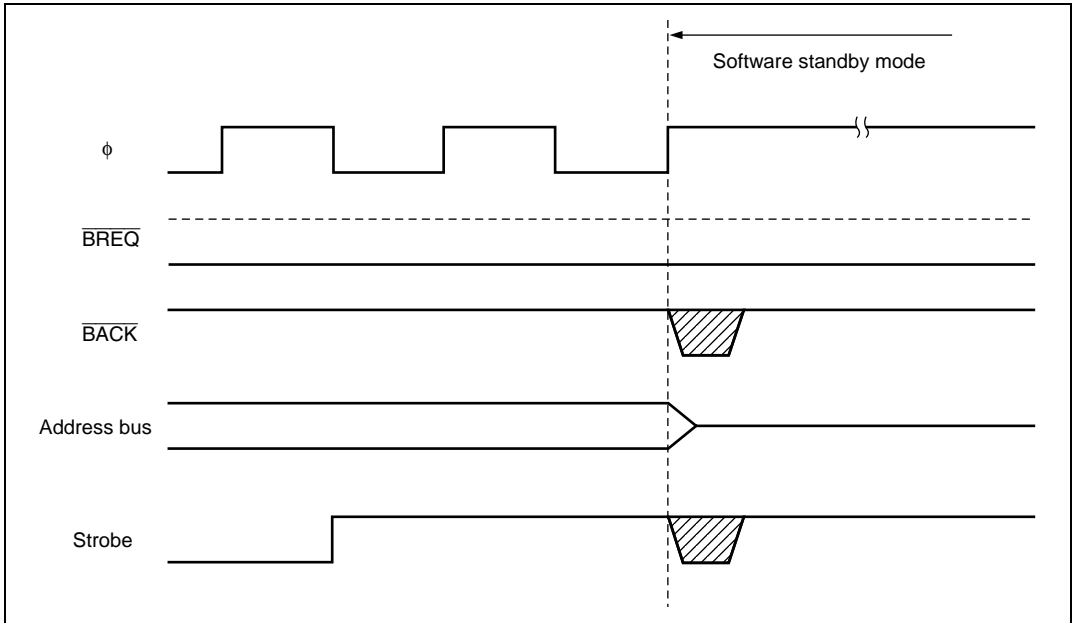

Figure 6.36 Bus-Released State and Software Standby Mode

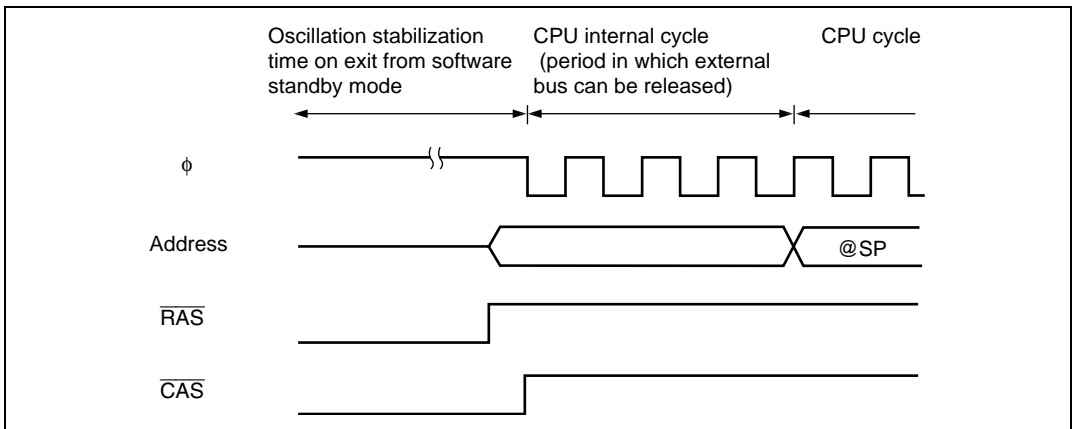

Figure 6.37 Self-Refresh Clearing

6.6 Interval Timer

6.6.1 Operation

When DRAM is not connected to the H8/3068F chip, the refresh timer can be used as an interval timer by clearing bits DRAS2 to DRAS0 in DRCRA to 0. After setting RTCOR, selection a clock source with bits CKS2 to CKS0 in RTMCSR, and set the CMIE bit to 1.

Timing of Setting of Compare Match Flag and Clearing by Compare Match: The CMF flag in RTMCSR is set to 1 by a compare match output when the RTCOR and RTCNT values match. The compare match signal is generated in the last state in which the values match (when RTCNT is updated from the matching value to a new value). Accordingly, when RTCNT and RTCOR match, the compare match signal is not generated until the next counter clock pulse. Figure 6.38 shows the timing.

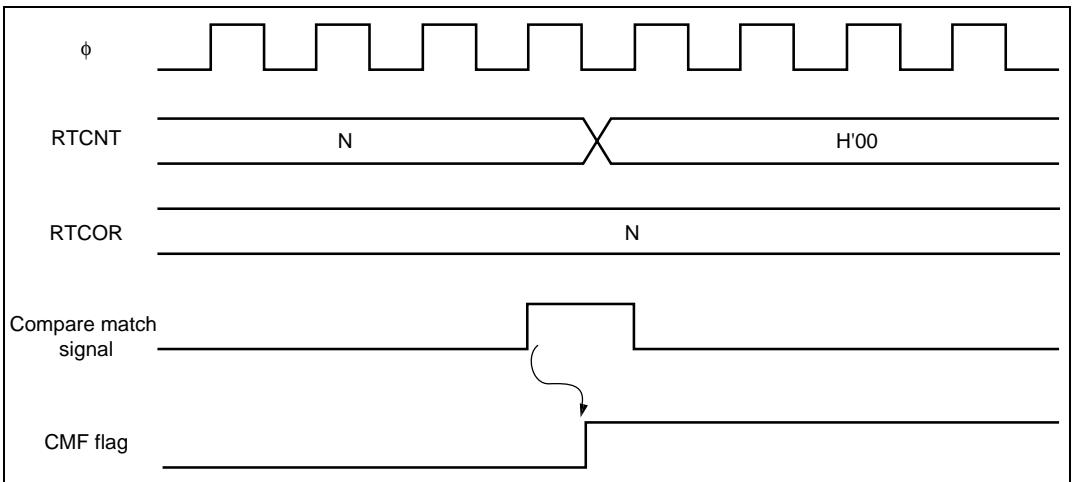

Figure 6.38 Timing of CMF Flag Setting

Operation in Power-Down State: The interval timer operates in sleep mode. It does not operate in hardware standby mode. In software standby mode, RTCNT and RTMCSR bits 7 and 6 are initialized, but RTMCSR bits 5 to 3 and RTCOR retain their settings prior to the transition to software standby mode.

Contention between RTCNT Write and Counter Clear: If a counter clear signal occurs in the T₃ state of an RTCNT write cycle, clearing of the counter takes priority and the write is not performed. See Figure 6.39.

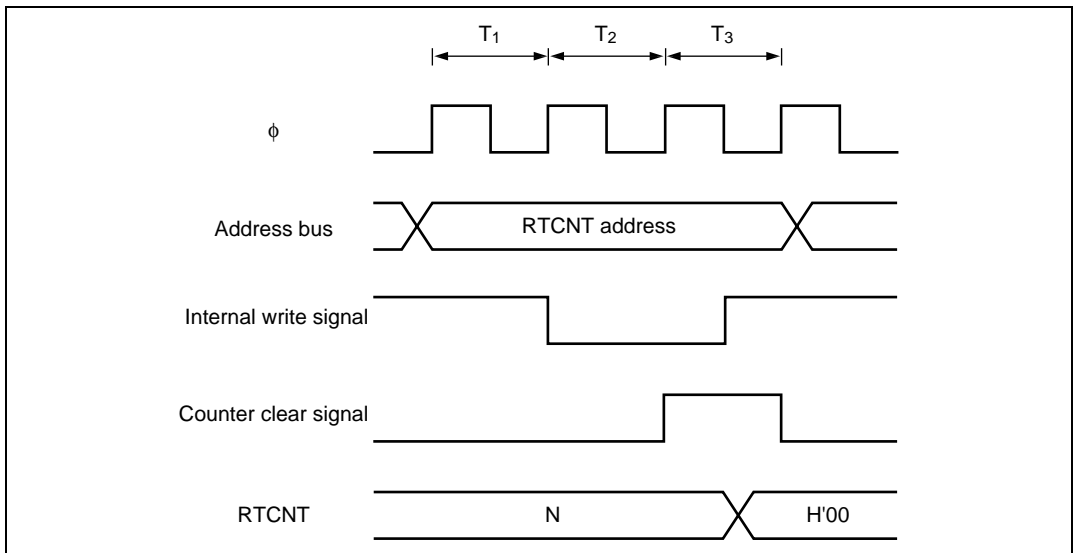

Figure 6.39 Contention between RTCNT Write and Clear

Contention between RTCNT Write and Increment: If an increment pulse occurs in the T_3 state of an RTCNT write cycle, writing takes priority and RTCNT is not incremented. See Figure 6.40.

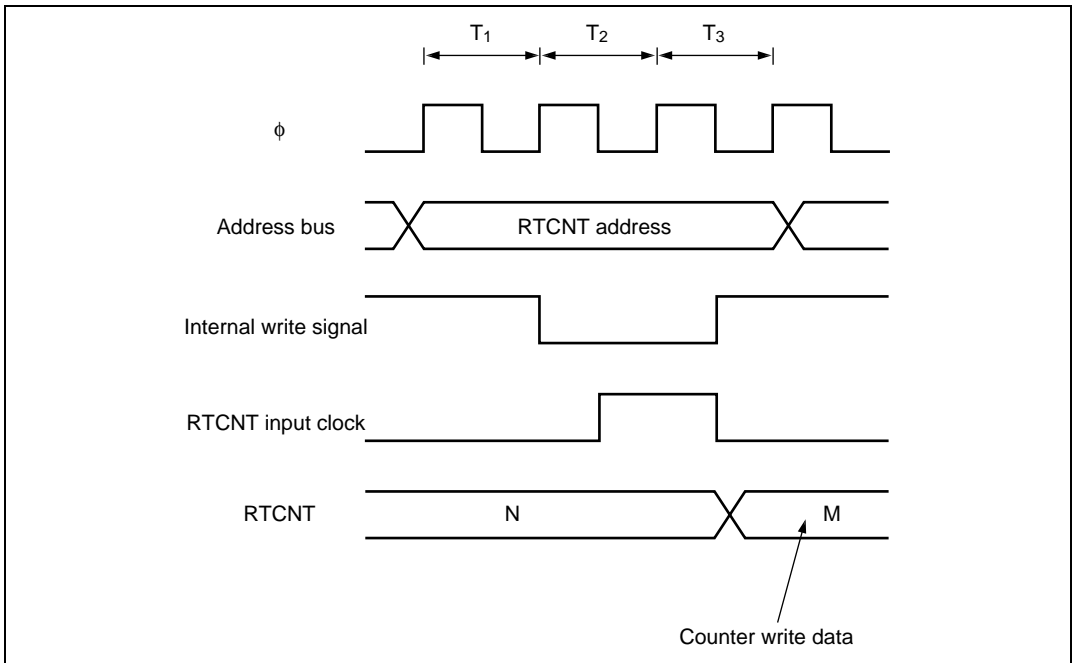

Figure 6.40 Contention between RTCNT Write and Increment

Contention between RTCOR Write and Compare Match: If a compare match occurs in the T_3 state of an RTCOR write cycle, writing takes priority and the compare match signal is inhibited. See Figure 6.41.

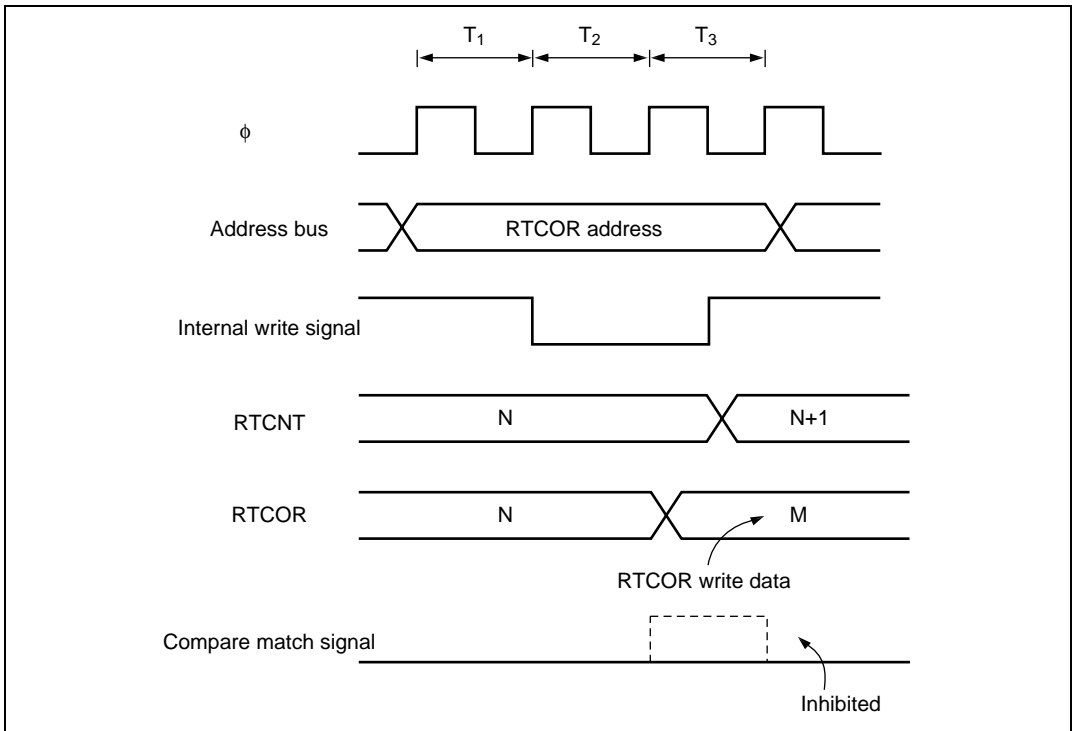
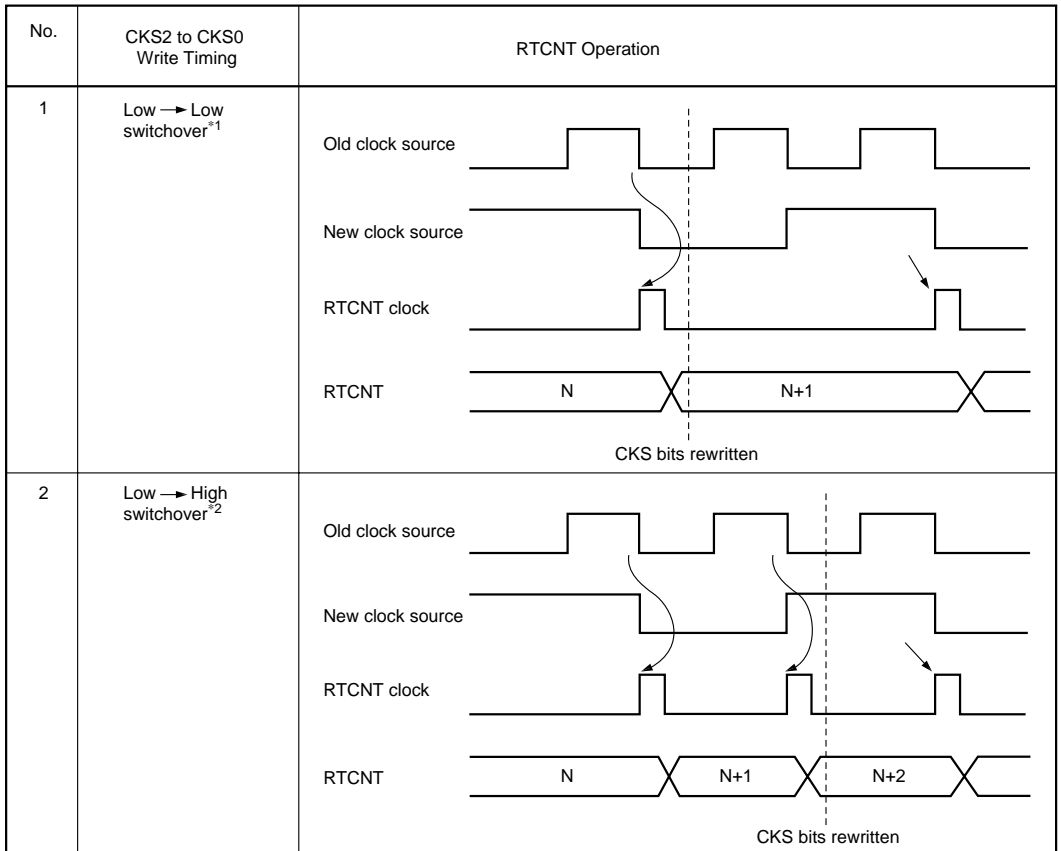
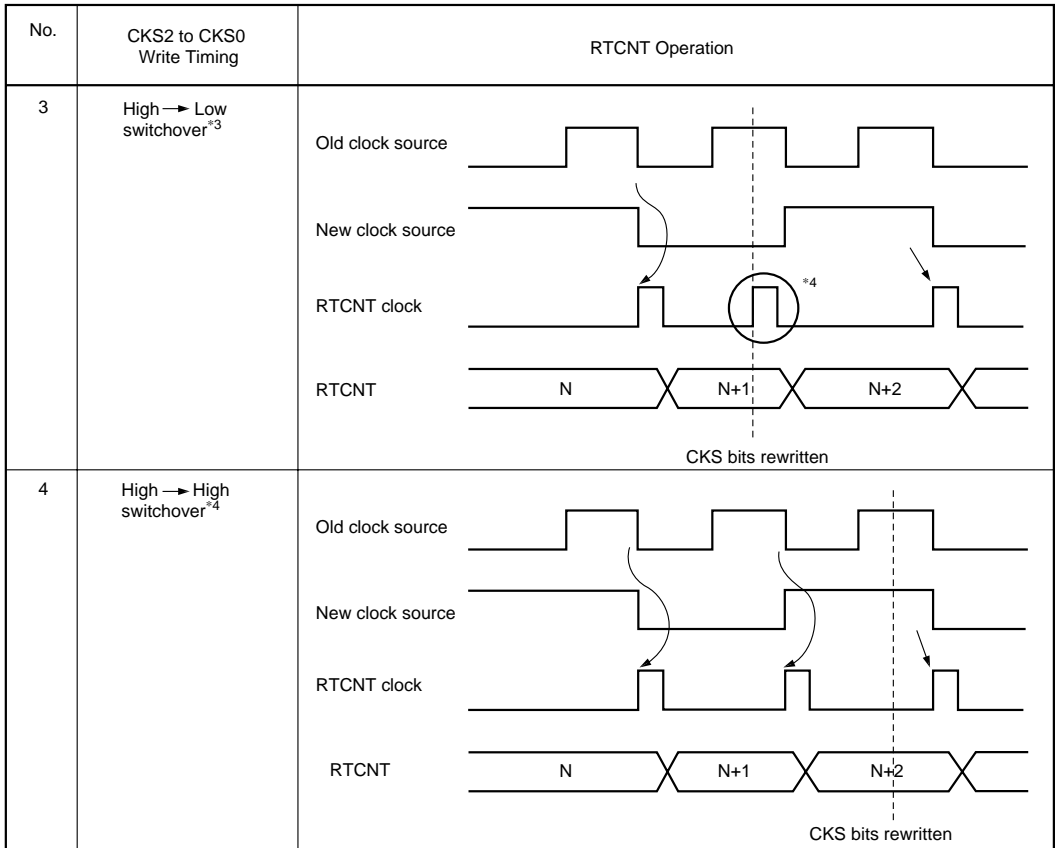

Figure 6.41 Contention between RTCOR Write and Compare Match

RTCNT Operation at Internal Clock Source Switchover: Switching internal clock sources may cause RTCNT to increment, depending on the switchover timing. Table 6.10 shows the relation between the time of the switchover (by writing to bits CKS2 to CKS0) and the operation of RTCNT.

The RTCNT input clock is generated from the internal clock source by detecting the falling edge of the internal clock. If a switchover is made from a high clock source to a low clock source, as in case No. 3 in table 6.10, the switchover will be regarded as a falling edge, an RTCNT clock pulse will be generated, and RTCNT will be incremented.

Table 6.10 Internal Clock Switchover and RTCNT Operation



- Notes:
1. Including switchovers from a low clock source to the halted state, and from the halted state to a low clock source.
 2. Including switchover from the halted state to a high clock source.
 3. Including switchover from a high clock source to the halted state.
 4. The switchover is regarded as a falling edge, causing RTCNT to increment.

6.7 Interrupt Sources

Compare match interrupts (CMI) can be generated when the refresh timer is used as an interval timer. Compare match interrupt requests are masked/unmasked with the CMIE bit in RTMCSR.

6.8 Burst ROM Interface

6.8.1 Overview

With the H8/3068F, external space area 0 can be designated as burst ROM space, and burst ROM space interfacing can be performed. The burst ROM space interface enables 16-bit organization ROM with burst access capability to be accessed at high speed. Area 0 is designated as burst ROM space by means of the BROME bit in BCR.

Continuous burst access of a maximum of four or eight words can be performed on external space area 0. Two or three states can be selected for burst access.

6.8.2 Basic Timing

The number of states in the initial cycle (full access) and a burst cycle of the burst ROM interface is determined by the setting of the AST0 bit in ASTCR. When the AST0 bit is set to 1, wait states can also be inserted in the initial cycle. Wait states cannot be inserted in a burst cycle.

Burst access of up to four words is performed when the BRSTS0 bit is cleared to 0 in BCR, and burst access of up to eight words when the BRSTS0 bit is set to 1. The number of burst access states is two when the BRSTS1 bit is cleared to 0, and three when the BRSTS1 bit is set to 1.

The basic access timing for burst ROM space is shown in figure 6.42.

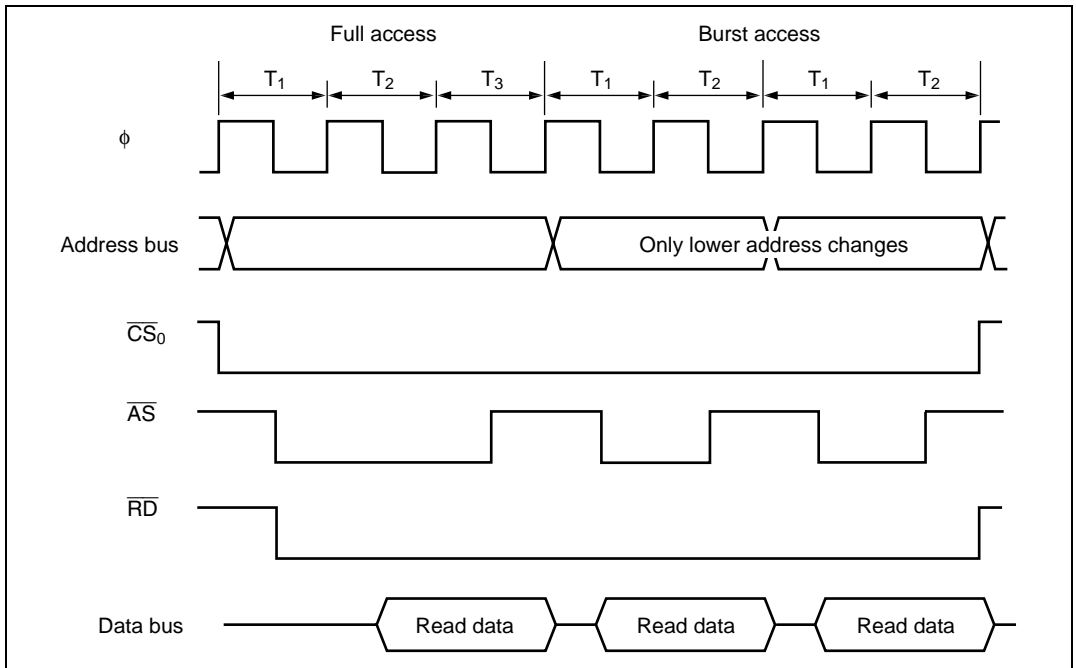

Figure 6.42 Example of Burst ROM Access Timing

6.8.3 Wait Control

As with the basic bus interface, either program wait insertion or pin wait insertion using the \overline{WAIT} pin can be used in the initial cycle (full access) of the burst ROM interface.

Wait states cannot be inserted in a burst cycle.

6.9 Idle Cycle

6.9.1 Operation

When the H8/3068F chip accesses external space, it can insert a 1-state idle cycle (T_1) between bus cycles in the following cases: (1) when read accesses between different areas occur consecutively, (2) when a write cycle occurs immediately after a read cycle, and (3) immediately after a DRAM space access. By inserting an idle cycle it is possible, for example, to avoid data collisions between ROM, which has a long output floating time, and high-speed memory, I/O interfaces, and so on.

The ICIS1 and ICIS0 bits in BCR both have an initial value of 1, so that an idle cycle is inserted in the initial state. If there are no data collisions, the ICIS bits can be cleared.

Consecutive Reads between Different Areas: If consecutive reads between different areas occur while the ICIS1 bit is set to 1 in BCR, an idle cycle is inserted at the start of the second read cycle.

Figure 6.43 shows an example of the operation in this case. In this example, bus cycle A is a read cycle from ROM with a long output floating time, and bus cycle B is a read cycle from SRAM, each being located in a different area. In (a), an idle cycle is not inserted, and a collision occurs in cycle B between the read data from ROM and that from SRAM. In (b), an idle cycle is inserted, and a data collision is prevented.

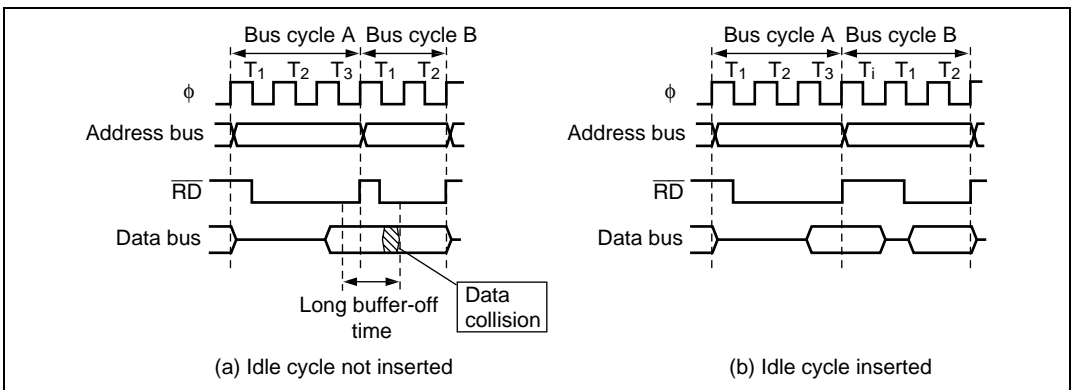

Figure 6.43 Example of Idle Cycle Operation (1) (ICIS1 = 1)

Write after Read: If an external write occurs after an external read while the ICIS0 bit is set to 1 in BCR, an idle cycle is inserted at the start of the write cycle.

Figure 6.44 shows an example of the operation in this case. In this example, bus cycle A is a read cycle from ROM with a long output floating time, and bus cycle B is a CPU write cycle.

In (a), an idle cycle is not inserted, and a collision occurs in cycle B between the read data from ROM and the CPU write data. In (b), an idle cycle is inserted, and a data collision is prevented.

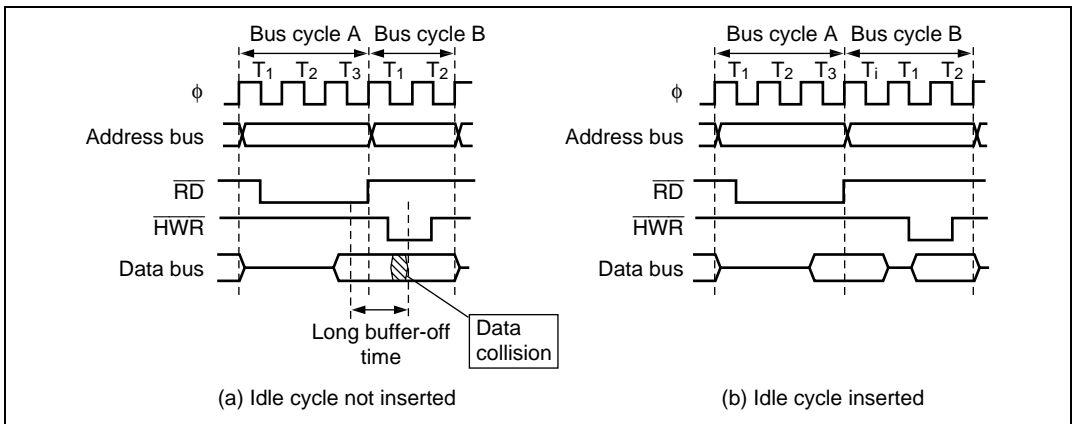

Figure 6.44 Example of Idle Cycle Operation (2) (ICIS0 = 1)

External Address Space Access Immediately after DRAM Space Access: If a DRAM space access is followed by a non-DRAM external access when \overline{HWR} and \overline{LWR} have been selected as the \overline{UCAS} and \overline{LCAS} output pins by means of the CSEL bit in DRCRB, a T_i cycle is inserted regardless of the settings of bits ICIS0 and ICIS1 in BCR. Figure 6.45 shows an example of the operation.

This is done to prevent simultaneous changing of the \overline{HWR} and \overline{LWR} signals used as \overline{UCAS} and \overline{LCAS} in DRAM space and \overline{CSn} for the space in the next cycle, and so avoid an erroneous write to the external device in the next cycle.

A T_i cycle is not inserted when PB4 and PB5 have been selected as the \overline{UCAS} and \overline{LCAS} output pins.

In the case of consecutive DRAM space access precharge cycles (T_p), the ICIS0 and ICIS1 bit settings are invalid. In the case of consecutive reads between different areas, for example, if the second access is a DRAM access, only a T_p cycle is inserted, and a T_i cycle is not. The timing in this case is shown in figure 6.46.

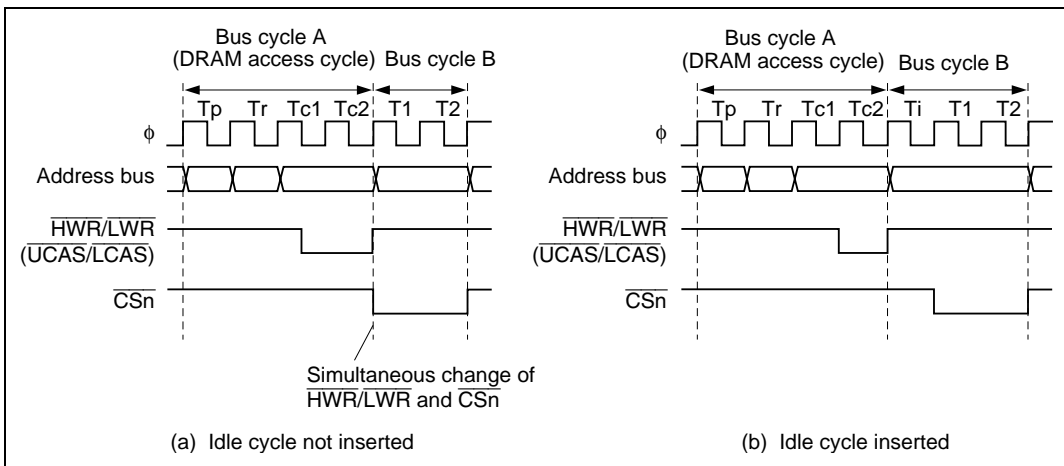

Figure 6.45 Example of Idle Cycle Operation (3) ($\overline{\text{HWR/LWR}}$ Used as $\overline{\text{UCAS/LCAS}}$)

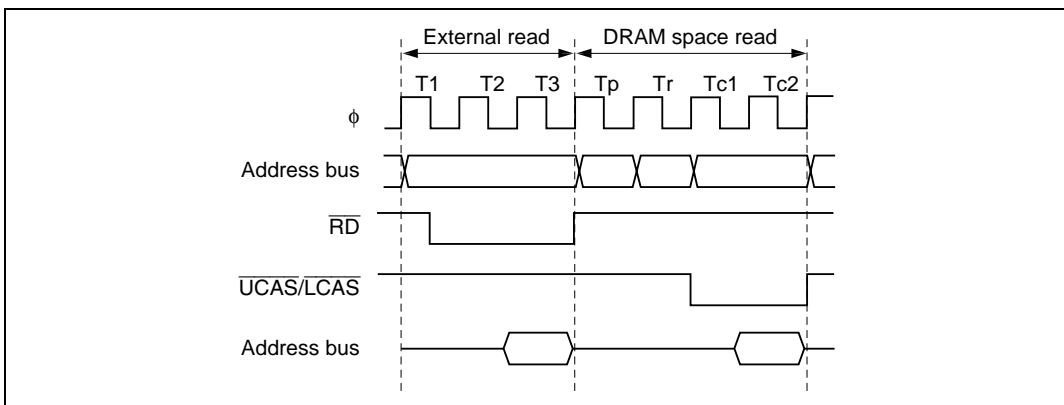

Figure 6.46 Example of Idle Cycle Operation (4) (Consecutive Precharge Cycles)

Usage Notes: When non-insertion of idle cycles is set, the rise (negation) of $\overline{\text{RD}}$ and the fall (assertion) of $\overline{\text{CSn}}$ may occur simultaneously. An example of the operation is shown in figure 6.47.

If consecutive reads between different external areas occur while the ICIS1 bit is cleared to 0 in BCR, or if a write cycle to a different external area occurs after an external read while the ICIS0 bit is cleared to 0, the $\overline{\text{RD}}$ negation in the first read cycle and the $\overline{\text{CSn}}$ assertion in the following bus cycle will occur simultaneously. Therefore, depending on the output delay time of each signal, it is possible that the low-level output of $\overline{\text{RD}}$ in the preceding read cycle and the low-level output of $\overline{\text{CSn}}$ in the following bus cycle will overlap.

A setting whereby idle cycle insertion is not performed can be made only when \overline{RD} and \overline{CSn} do not change simultaneously, or when it does not matter if they do.

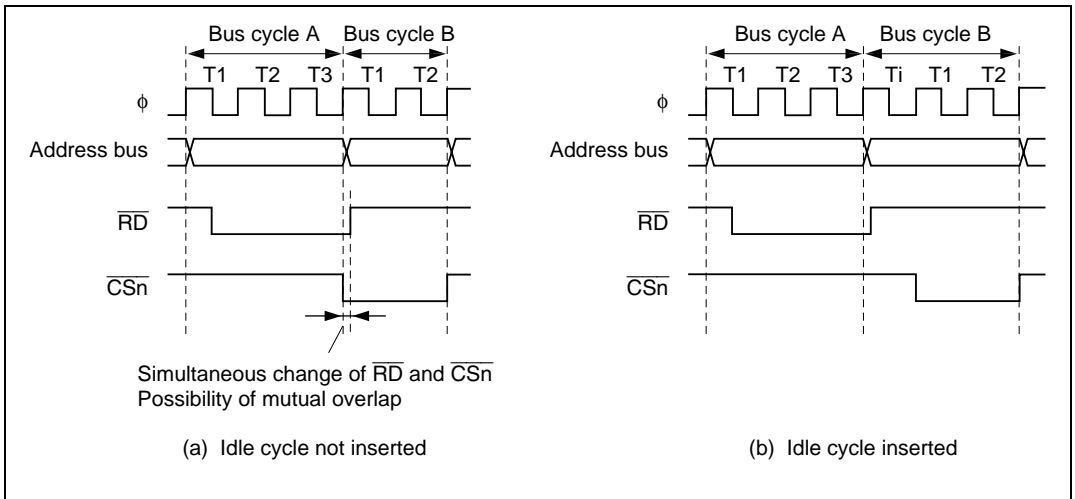

Figure 6.47 Example of Idle Cycle Operation (5)

6.9.2 Pin States in Idle Cycle

Table 6.11 shows the pin states in an idle cycle.

Table 6.11 Pin States in Idle Cycle

Pins	Pin State
A_{23} to A_0	Next cycle address value
D_{15} to D_0	High impedance
\overline{CSn}	High*
\overline{UCAS} , \overline{LCAS}	High
\overline{AS}	High
\overline{RD}	High
\overline{HWR}	High
\overline{LWR}	High

Note: * Remains low in DRAM space RAS down mode.

6.10 Bus Arbiter

The bus controller has a built-in bus arbiter that arbitrates between different bus masters. There are four bus masters: the CPU, DMA controller (DMAC), DRAM interface, and an external bus master. When a bus master has the bus right it can carry out read, write, or refresh access. Each bus master uses a bus request signal to request the bus right. At fixed times the bus arbiter determines priority and uses a bus acknowledge signal to grant the bus to a bus master, which can then operate using the bus.

The bus arbiter checks whether the bus request signal from a bus master is active or inactive, and returns an acknowledge signal to the bus master. When two or more bus masters request the bus, the highest-priority bus master receives an acknowledge signal. The bus master that receives an acknowledge signal can continue to use the bus until the acknowledge signal is deactivated.

The bus master priority order is:

(High) External bus master > DRAM interface > DMAC > CPU (Low)

The bus arbiter samples the bus request signals and determines priority at all times, but it does not always grant the bus immediately, even when it receives a bus request from a bus master with higher priority than the current bus master. Each bus master has certain times at which it can release the bus to a higher-priority bus master.

6.10.1 Operation

CPU: The CPU is the lowest-priority bus master. If the DMAC, DRAM interface, or an external bus master requests the bus while the CPU has the bus right, the bus arbiter transfers the bus right to the bus master that requested it. The bus right is transferred at the following times:

- The bus right is transferred at the boundary of a bus cycle. If word data is accessed by two consecutive byte accesses, however, the bus right is not transferred between the two byte accesses.
- If another bus master requests the bus while the CPU is performing internal operations, such as executing a multiply or divide instruction, the bus right is transferred immediately. The CPU continues its internal operations.
- If another bus master requests the bus while the CPU is in sleep mode, the bus right is transferred immediately.

DMAC: When the DMAC receives an activation request, it requests the bus right from the bus arbiter. If the DMAC is bus master and the DRAM interface or an external bus master requests the bus, the bus arbiter transfers the bus right from the DMAC to the bus master that requested the bus. The bus right is transferred at the following times.

The bus right is transferred when the DMAC finishes transferring one byte or one word. A DMAC transfer cycle consists of a read cycle and a write cycle. The bus right is not transferred between the read cycle and the write cycle.

There is a priority order among the DMAC channels. For details see section 7.4.9, Multiple-Channel Operation.

DRAM Interface: The DRAM interface requests the bus right from the bus arbiter when a refresh cycle request is issued, and releases the bus at the end of the refresh cycle. For details see section 6.5, DRAM Interface.

External Bus Master: When the BRLE bit is set to 1 in BRCCR, the bus can be released to an external bus master. The external bus master has highest priority, and requests the bus right from the bus arbiter by driving the $\overline{\text{BREQ}}$ signal low. Once the external bus master acquires the bus, it keeps the bus until the $\overline{\text{BREQ}}$ signal goes high. While the bus is released to an external bus master, the H8/3068F chip holds the address bus, data bus, bus control signals ($\overline{\text{AS}}$, $\overline{\text{RD}}$, $\overline{\text{HWR}}$, and $\overline{\text{LWR}}$), and chip select signals ($\overline{\text{CS}}_n$: $n = 7$ to 0) in the high-impedance state, and holds the $\overline{\text{BACK}}$ pin in the low output state.

The bus arbiter samples the $\overline{\text{BREQ}}$ pin at the rise of the system clock (ϕ). If $\overline{\text{BREQ}}$ is low, the bus is released to the external bus master at the appropriate opportunity. The $\overline{\text{BREQ}}$ signal should be held low until the $\overline{\text{BACK}}$ signal goes low.

When the $\overline{\text{BREQ}}$ pin is high in two consecutive samples, the $\overline{\text{BACK}}$ pin is driven high to end the bus-release cycle.

Figure 6.48 shows the timing when the bus right is requested by an external bus master during a read cycle in a two-state access area. There is a minimum interval of three states from when the $\overline{\text{BREQ}}$ signal goes low until the bus is released.

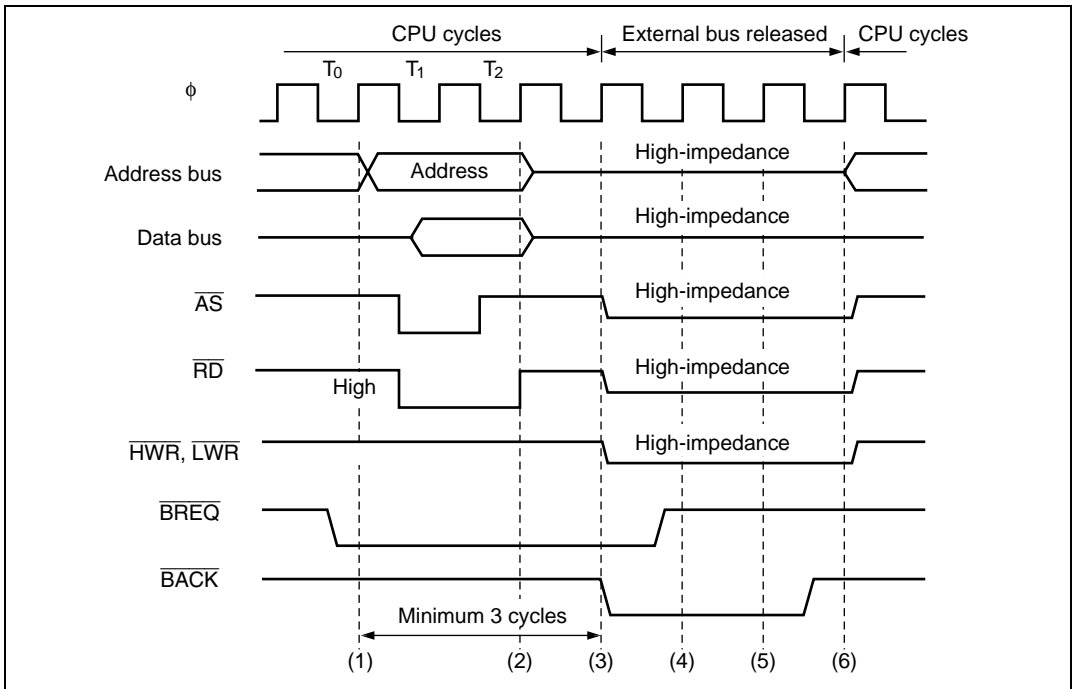

Figure 6.48 Example of External Bus Master Operation

In the event of contention with a bus request from an external bus master when a transition is made to software standby mode, the \overline{BACK} and strobe states may be indeterminate after the transition to software standby mode (see figure 6.36).

When software standby mode is used, the BRLE bit should be cleared to 0 in BRCR before executing the SLEEP instruction.

6.11 Register and Pin Input Timing

6.11.1 Register Write Timing

ABWCR, ASTCR, WCRH, and WCRL Write Timing: Data written to ABWCR, ASTCR, WCRH, and WCRL takes effect starting from the next bus cycle. Figure 6.49 shows the timing when an instruction fetched from area 0 changes area 0 from three-state access to two-state access.

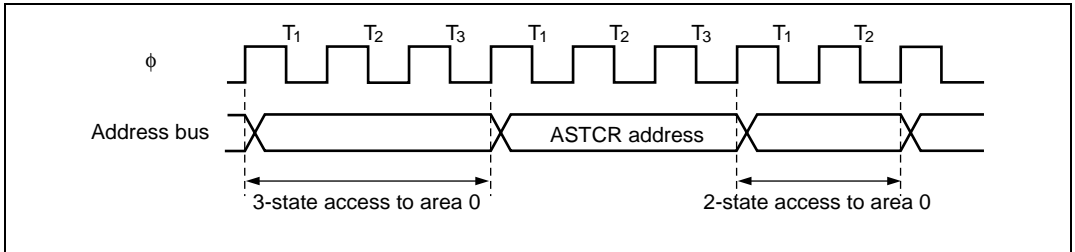

Figure 6.49 ASTCR Write Timing

DDR and CSCR Write Timing: Data written to DDR or CSCR for the port corresponding to the \overline{CS}_n pin to switch between \overline{CS}_n output and generic input takes effect starting from the T_3 state of the DDR write cycle. Figure 6.50 shows the timing when the \overline{CS}_1 pin is changed from generic input to \overline{CS}_1 output.

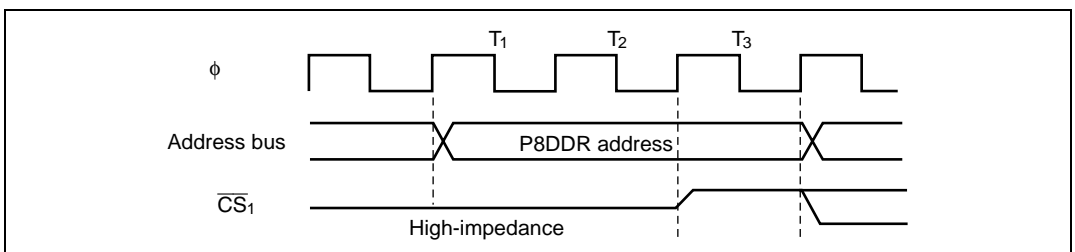

Figure 6.50 DDR Write Timing

BRCR Write Timing: Data written to BRCR to switch between A_{23} , A_{22} , A_{21} , or A_{20} output and generic input or output takes effect starting from the T_3 state of the BRCR write cycle. Figure 6.51 shows the timing when a pin is changed from generic input to A_{23} , A_{22} , A_{21} , or A_{20} output.

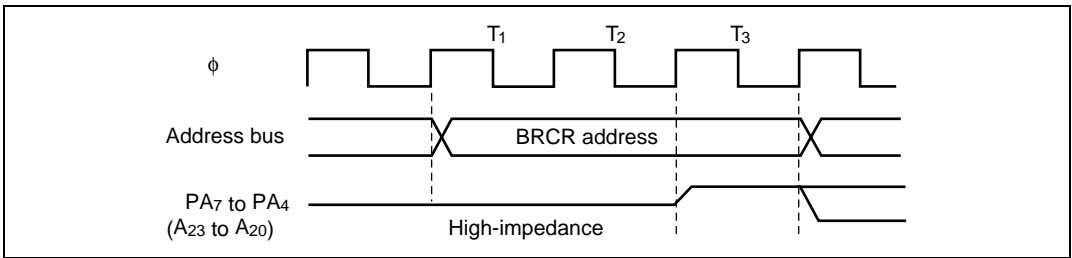

Figure 6.51 BRCR Write Timing

6.11.2 \overline{BREQ} Pin Input Timing

After driving the \overline{BREQ} pin low, hold it low until \overline{BACK} goes low. If \overline{BREQ} returns to the high level before \overline{BACK} goes low, the bus arbiter may operate incorrectly.

To terminate the external-bus-released state, hold the \overline{BREQ} signal high for at least three states. If \overline{BREQ} is high for too short an interval, the bus arbiter may operate incorrectly.

Section 7 DMA Controller

7.1 Overview

The H8/3068F has an on-chip DMA controller (DMAC) that can transfer data on up to four channels.

When the DMA controller is not used, it can be independently halted to conserve power. For details see section 20.6, Module Standby Function.

7.1.1 Features

DMAC features are listed below.

- Selection of short address mode or full address mode
 - Short address mode
 - 8-bit source address and 24-bit destination address, or vice versa
 - Maximum four channels available
 - Selection of I/O mode, idle mode, or repeat mode
 - Full address mode
 - 24-bit source and destination addresses
 - Maximum two channels available
 - Selection of normal mode or block transfer mode
- Directly addressable 16-Mbyte address space
- Selection of byte or word transfer
- Activation by internal interrupts, external requests, or auto-request (depending on transfer mode)
 - 16-bit timer compare match/input capture interrupts (×3)
 - Serial communication interface (SCI channel 0) transmit-data-empty/receive-data-full interrupts
 - External requests
 - Auto-request
 - A/D converter conversion-end interrupt

7.1.2 Block Diagram

Figure 7.1 shows a DMAC block diagram.

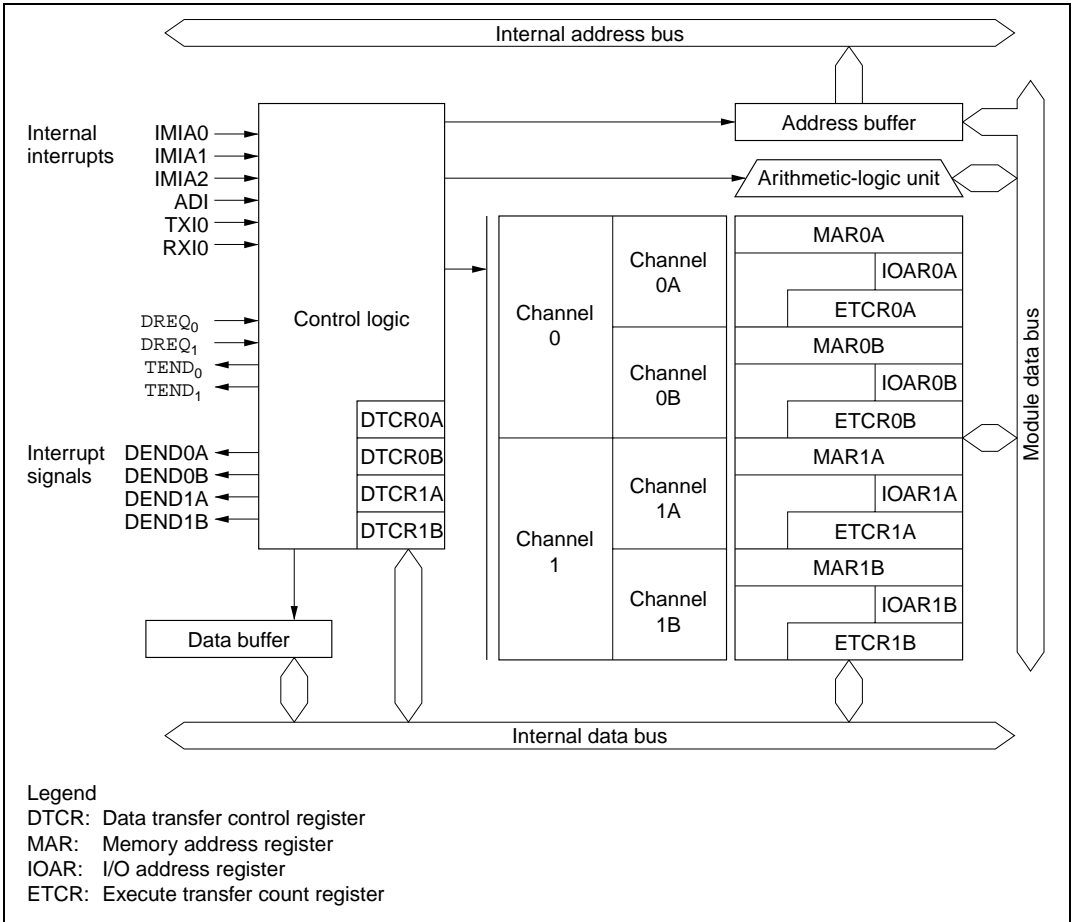

Figure 7.1 Block Diagram of DMAC

7.1.3 Functional Overview

Table 7.1 gives an overview of the DMAC functions.

Table 7.1 DMAC Functional Overview

Transfer Mode	Activation	Address Reg. Length	
		Source	Destination
Short address mode	I/O mode	24	8
	<ul style="list-style-type: none"> Transfers one byte or one word per request Increments or decrements the memory address by 1 or 2 Executes 1 to 65,536 transfers 		
	<ul style="list-style-type: none"> Compare match/input capture A interrupts from 16-bit timer channels 0 to 2 Transmit-data-empty interrupt from SCI channel 0 		
Idle mode	<ul style="list-style-type: none"> Transfers one byte or one word per request Holds the memory address fixed Executes 1 to 65,536 transfers 	8	24
	<ul style="list-style-type: none"> Conversion-end interrupt from A/D converter Receive-data-full interrupt from SCI channel 0 	24	8
	<ul style="list-style-type: none"> External request 		
Repeat mode	<ul style="list-style-type: none"> Transfers one byte or one word per request Increments or decrements the memory address by 1 or 2 Executes a specified number (1 to 255) of transfers, then returns to the initial state and continues 	24	24
	<ul style="list-style-type: none"> Auto-request External request 		
	<ul style="list-style-type: none"> Retains the transfer request internally Executes a specified number(1 to 65,536) of transfers continuously Selection of burst mode or cycle-steal mode External request Transfers one byte or one word per request Executes 1 to 65,536 transfers 		
Full address mode	Normal mode	24	24
	<ul style="list-style-type: none"> Auto-request External request 		
	<ul style="list-style-type: none"> Compare match/ input capture A interrupts from 16-bit timer channels 0 to 2 External request Conversion-end interrupt from A/D converter 		
Block transfer	<ul style="list-style-type: none"> Transfers one block of a specified size per request Executes 1 to 65,536 transfers Allows either the source or destination to be a fixed block area Block size can be 1 to 255 bytes or words 	24	24
	<ul style="list-style-type: none"> Compare match/ input capture A interrupts from 16-bit timer channels 0 to 2 External request Conversion-end interrupt from A/D converter 		
	<ul style="list-style-type: none"> Auto-request External request 		

7.1.4 Input/Output Pins

Table 7.2 lists the DMAC pins.

Table 7.2 DMAC Pins

Channel	Name	Abbrevia- tion	Input/ Output	Function
0	DMA request 0	$\overline{\text{DREQ}}_0$	Input	External request for DMAC channel 0
	Transfer end 0	$\overline{\text{TEND}}_0$	Output	Transfer end on DMAC channel 0
1	DMA request 1	$\overline{\text{DREQ}}_1$	Input	External request for DMAC channel 1
	Transfer end 1	$\overline{\text{TEND}}_1$	Output	Transfer end on DMAC channel 1

Note: External requests cannot be made to channel A in short address mode.

7.1.5 Register Configuration

Table 7.3 lists the DMAC registers.

Table 7.3 DMAC Registers

Channel	Address*	Name	Abbreviation	R/W	Initial Value
0	H'FFF20	Memory address register 0AR	MAR0AR	R/W	Undetermined
	H'FFF21	Memory address register 0AE	MAR0AE	R/W	Undetermined
	H'FFF22	Memory address register 0AH	MAR0AH	R/W	Undetermined
	H'FFF23	Memory address register 0AL	MAR0AL	R/W	Undetermined
	H'FFF26	I/O address register 0A	IOAR0A	R/W	Undetermined
	H'FFF24	Execute transfer count register 0AH	ETCR0AH	R/W	Undetermined
	H'FFF25	Execute transfer count register 0AL	ETCR0AL	R/W	Undetermined
	H'FFF27	Data transfer control register 0A	DTCR0A	R/W	H'00
	H'FFF28	Memory address register 0BR	MAR0BR	R/W	Undetermined
	H'FFF29	Memory address register 0BE	MAR0BE	R/W	Undetermined
	H'FFF2A	Memory address register 0BH	MAR0BH	R/W	Undetermined
	H'FFF2B	Memory address register 0BL	MAR0BL	R/W	Undetermined
	H'FFF2E	I/O address register 0B	IOAR0B	R/W	Undetermined
	H'FFF2C	Execute transfer count register 0BH	ETCR0BH	R/W	Undetermined
	H'FFF2D	Execute transfer count register 0BL	ETCR0BL	R/W	Undetermined
	H'FFF2F	Data transfer control register 0B	DTCR0B	R/W	H'00
1	H'FFF30	Memory address register 1AR	MAR1AR	R/W	Undetermined
	H'FFF31	Memory address register 1AE	MAR1AE	R/W	Undetermined
	H'FFF32	Memory address register 1AH	MAR1AH	R/W	Undetermined
	H'FFF33	Memory address register 1AL	MAR1AL	R/W	Undetermined
	H'FFF36	I/O address register 1A	IOAR1A	R/W	Undetermined
	H'FFF34	Execute transfer count register 1AH	ETCR1AH	R/W	Undetermined
	H'FFF35	Execute transfer count register 1AL	ETCR1AL	R/W	Undetermined
	H'FFF37	Data transfer control register 1A	DTCR1A	R/W	H'00
	H'FFF38	Memory address register 1BR	MAR1BR	R/W	Undetermined
	H'FFF39	Memory address register 1BE	MAR1BE	R/W	Undetermined
	H'FFF3A	Memory address register 1BH	MAR1BH	R/W	Undetermined
	H'FFF3B	Memory address register 1BL	MAR1BL	R/W	Undetermined

Channel	Address*	Name	Abbreviation	R/W	Initial Value
1	H'FFF3E	I/O address register 1B	IOAR1B	R/W	Undetermined
	H'FFF3C	Execute transfer count register 1BH	ETCR1BH	R/W	Undetermined
	H'FFF3D	Execute transfer count register 1BL	ETCR1BL	R/W	Undetermined
	H'FFF3F	Data transfer control register 1B	DTCR1B	R/W	H'00

Note: * The lower 20 bits of the address are indicated.

7.2 Register Descriptions (1) (Short Address Mode)

In short address mode, transfers can be carried out independently on channels A and B. Short address mode is selected by bits DTS2A and DTS1A in data transfer control register A (DTCRA) as indicated in table 7.4.

Table 7.4 Selection of Short and Full Address Modes

Channel	Bit 2 DTS2A	Bit 1 DTS1A	Description
0	1	1	DMAC channel 0 operates as one channel in full address mode
	Other than above		DMAC channels 0A and 0B operate as two independent channels in short address mode
1	1	1	DMAC channel 1 operates as one channel in full address mode
	Other than above		DMAC channels 1A and 1B operate as two independent channels in short address mode

7.2.1 Memory Address Registers (MAR)

A memory address register (MAR) is a 32-bit readable/writable register that specifies a source or destination address. The transfer direction is determined automatically from the activation source.

An MAR consists of four 8-bit registers designated MARR, MARE, MARH, and MARL. All bits of MARR are reserved; they cannot be modified and are always read as 1.

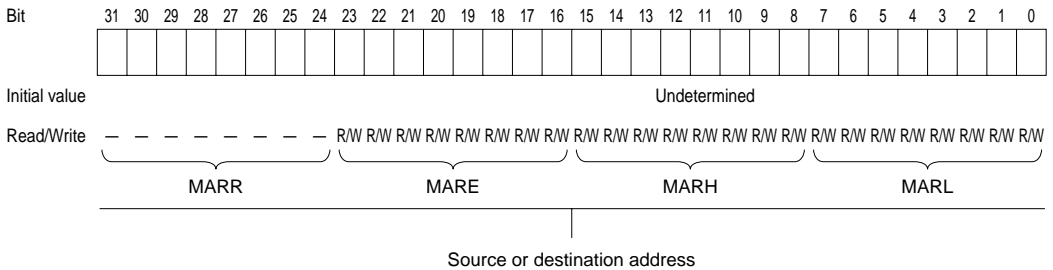

An MAR functions as a source or destination address register depending on how the DMAC is activated: as a destination address register if activation is by a receive-data-full interrupt from serial communication interface (SCI) channel 0 or by an A/D converter conversion-end interrupt, and as a source address register otherwise.

The MAR value is incremented or decremented each time one byte or word is transferred, automatically updating the source or destination memory address. For details, see section 7.3.4, Data Transfer Control Registers (DTCR).

The MARs are not initialized by a reset or in standby mode.

7.2.2 I/O Address Registers (IOAR)

An I/O address register (IOAR) is an 8-bit readable/writable register that specifies a source or destination address. The IOAR value is the lower 8 bits of the address. The upper 16 address bits are all 1 (H'FFFF).

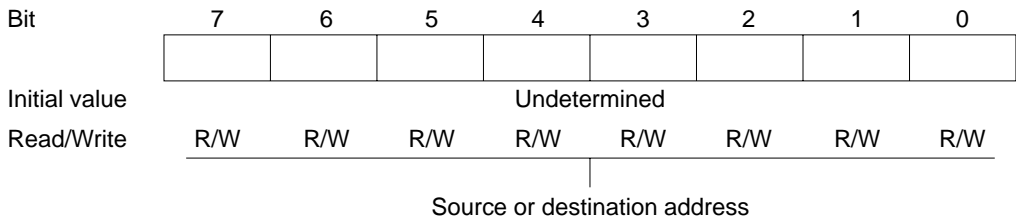

An IOAR functions as a source or destination address register depending on how the DMAC is activated: as a destination address register if activation is by a receive-data-full interrupt from serial communication interface (SCI) channel 0 or by an A/D converter conversion-end interrupt, and as a source address register otherwise.

The IOAR value is held fixed. It is not incremented or decremented when a transfer is executed.

The IOARs are not initialized by a reset or in standby mode.

7.2.3 Execute Transfer Count Registers (ETCR)

An execute transfer count register (ETCR) is a 16-bit readable/writable register that specifies the number of transfers to be executed. These registers function in one way in I/O mode and idle mode, and another way in repeat mode.

- I/O mode and idle mode

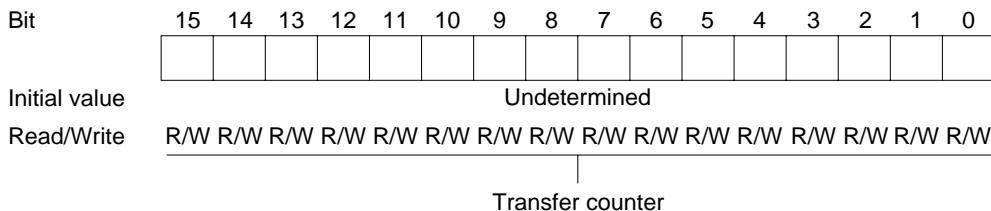

In I/O mode and idle mode, ETCR functions as a 16-bit counter. The count is decremented by 1 each time one transfer is executed. The transfer ends when the count reaches H'0000.

- Repeat mode

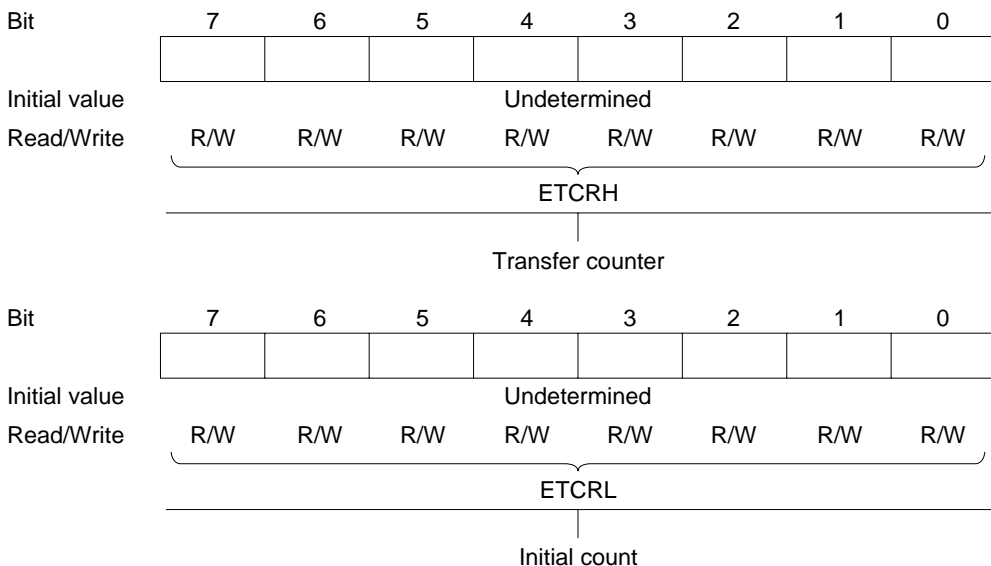

In repeat mode, ETCRH functions as an 8-bit transfer counter and ETCRL holds the initial transfer count. ETCRH is decremented by 1 each time one transfer is executed. When ETCRH reaches H'00, the value in ETCRL is reloaded into ETCRH and the same operation is repeated.

The ETCRs are not initialized by a reset or in standby mode.

7.2.4 Data Transfer Control Registers (DTCR)

A data transfer control register (DTCR) is an 8-bit readable/writable register that controls the operation of one DMAC channel.

Bit	7	6	5	4	3	2	1	0
	DTE	DTSZ	DTID	RPE	DTIE	DTS2	DTS1	DTS0
Initial value	0	0	0	0	0	0	0	0
Read/Write	R/W	R/W	R/W	R/W	R/W	R/W	R/W	R/W

<p>Data transfer enable Enables or disables data transfer</p>	<p>Data transfer size Selects byte or word size</p>	<p>Data transfer increment/decrement Selects whether to increment or decrement the memory address register</p>	<p>Repeat enable Selects repeat mode</p>	<p>Data transfer interrupt enable Enables or disables the CPU interrupt at the end of the transfer</p>	<p>Data transfer select These bits select the data transfer activation source</p>
--	--	---	---	---	--

The DTCRs are initialized to H'00 by a reset and in standby mode.

Bit 7—Data Transfer Enable (DTE): Enables or disables data transfer on a channel. When the DTE bit is set to 1, the channel waits for a transfer to be requested, and executes the transfer when activated as specified by bits DTS2 to DTS0. When DTE is 0, the channel is disabled and does not accept transfer requests. DTE is set to 1 by reading the register when DTE is 0, then writing 1.

Bit 7

DTE	Description
0	Data transfer is disabled. In I/O mode or idle mode, DTE is cleared to 0 (Initial value) when the specified number of transfers have been completed
1	Data transfer is enabled

If DTIE is set to 1, a CPU interrupt is requested when DTIE is cleared to 0.

Bit 6—Data Transfer Size (DTSZ): Selects the data size of each transfer.

Bit 6 DTSZ	Description	
0	Byte-size transfer	(Initial value)
1	Word-size transfer	

Bit 5—Data Transfer Increment/Decrement (DTID): Selects whether to increment or decrement the memory address register (MAR) after a data transfer in I/O mode or repeat mode.

Bit 5 DTID	Description	
0	MAR is incremented after each data transfer <ul style="list-style-type: none"> • If DTSZ = 0, MAR is incremented by 1 after each transfer • If DTSZ = 1, MAR is incremented by 2 after each transfer 	(Initial value)
1	MAR is decremented after each data transfer <ul style="list-style-type: none"> • If DTSZ = 0, MAR is decremented by 1 after each transfer • If DTSZ = 1, MAR is decremented by 2 after each transfer 	

MAR is not incremented or decremented in idle mode.

Bit 4—Repeat Enable (RPE): Selects whether to transfer data in I/O mode, idle mode, or repeat mode.

Bit 4 RPE	Bit 3 DTIE	Description	
0	0	I/O mode	(Initial value)
	1		
1	0	Repeat mode	
	1	Idle mode	

Operations in these modes are described in sections 7.4.2, I/O Mode, 7.4.3, Idle Mode, and 7.4.4, Repeat Mode.

Bit 3—Data Transfer Interrupt Enable (DTIE): Enables or disables the CPU interrupt (DEND) requested when the DTE bit is cleared to 0.

Bit 3

DTIE	Description
0	The DEND interrupt requested by DTE is disabled (Initial value)
1	The DEND interrupt requested by DTE is enabled

Bits 2 to 0—Data Transfer Select (DTS2, DTS1, DTS0): These bits select the data transfer activation source. Some of the selectable sources differ between channels A and B.

Bit 2 DTS2	Bit 1 DTS1	Bit 0 DTS0	Description
0	0	0	Compare match/input capture A interrupt from 16-bit timer channel 0 (Initial value)
		1	Compare match/input capture A interrupt from 16-bit timer channel 1
	1	0	Compare match/input capture A interrupt from 16-bit timer channel 2
		1	Conversion-end interrupt from A/D converter
1	0	0	Transmit-data-empty interrupt from SCI channel 0
		1	Receive-data-full interrupt from SCI channel 0
	1	0	Falling edge of $\overline{\text{DREQ}}$ input (channel B) Transfer in full address mode (channel A)
		1	Low level of $\overline{\text{DREQ}}$ input (channel B) Transfer in full address mode (channel A)

Note: See section 7.3.4, Data Transfer Control Registers (DTCR).

The same internal interrupt can be selected as an activation source for two or more channels at once. In that case the channels are activated in a priority order, highest-priority channel first. For the priority order, see section 7.4.9, Multiple-Channel Operation.

When a channel is enabled (DTE = 1), its selected DMAC activation source cannot generate a CPU interrupt.

7.3 Register Descriptions (2) (Full Address Mode)

In full address mode the A and B channels operate together. Full address mode is selected as indicated in table 7.4.

7.3.1 Memory Address Registers (MAR)

A memory address register (MAR) is a 32-bit readable/writable register. MARA functions as the source address register of the transfer, and MARB as the destination address register.

An MAR consists of four 8-bit registers designated MARR, MARE, MARH, and MARL. All bits of MARR are reserved; they cannot be modified and are always read as 1. (Write is invalid.)

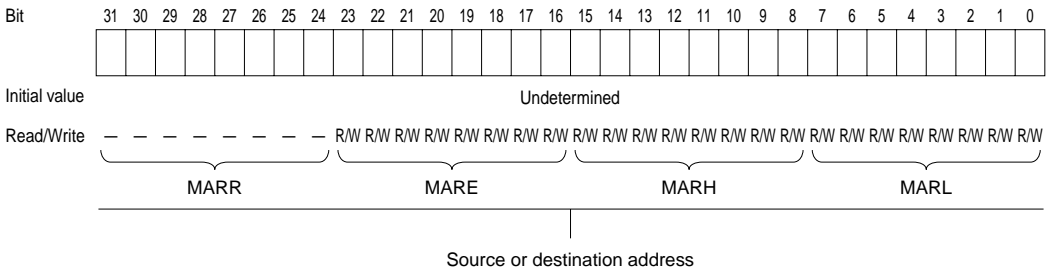

The MAR value is incremented or decremented each time one byte or word is transferred, automatically updating the source or destination memory address. For details, see section 7.3.4, Data Transfer Control Registers (DTCR).

The MARs are not initialized by a reset or in standby mode.

7.3.2 I/O Address Registers (IOAR)

The I/O address registers (IOARs) are not used in full address mode.

7.3.3 Execute Transfer Count Registers (ETCR)

An execute transfer count register (ETCR) is a 16-bit readable/writable register that specifies the number of transfers to be executed. The functions of these registers differ between normal mode and block transfer mode.

- Normal mode

ETCRA

Bit	15	14	13	12	11	10	9	8	7	6	5	4	3	2	1	0
Initial value																
Read/Write	R/W	R/W	R/W	R/W	R/W	R/W	R/W	R/W	R/W	R/W	R/W	R/W	R/W	R/W	R/W	R/W

Undetermined

Transfer counter

ETCRB: Is not used in normal mode.

In normal mode ETCRA functions as a 16-bit transfer counter. The count is decremented by 1 each time one transfer is executed. The transfer ends when the count reaches H'0000. ETCRB is not used.

- Block transfer mode

ETCRA

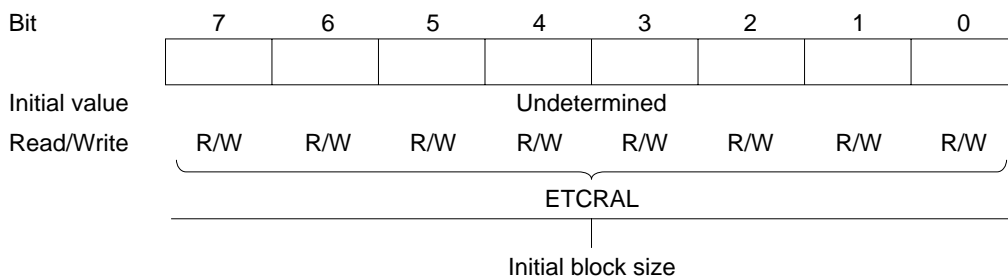
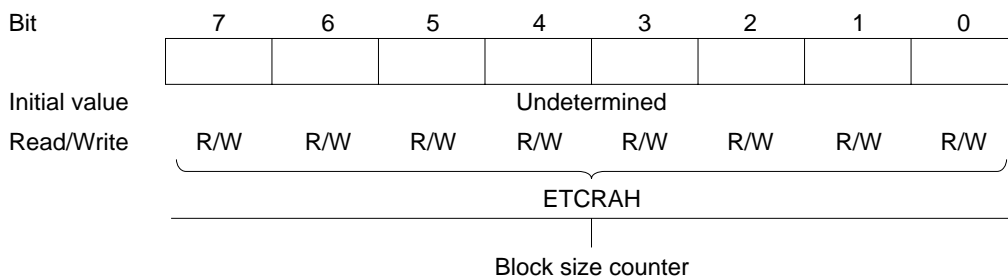

ETCRB

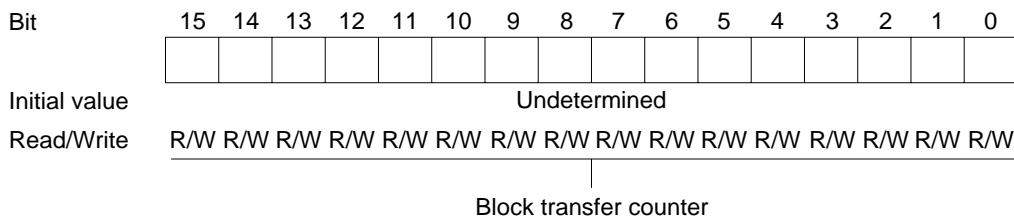

In block transfer mode, ETCRAH functions as an 8-bit block size counter. ETCRAL holds the initial block size. ETCRAH is decremented by 1 each time one byte or word is transferred. When the count reaches H'00, ETCRAH is reloaded from ETCRAL. Blocks consisting of an arbitrary number of bytes or words can be transferred repeatedly by setting the same initial block size value in ETCRAH and ETCRAL.

In block transfer mode ETCRB functions as a 16-bit block transfer counter. ETCRB is decremented by 1 each time one block is transferred. The transfer ends when the count reaches H'0000.

The ETCRs are not initialized by a reset or in standby mode.

7.3.4 Data Transfer Control Registers (DTCR)

The data transfer control registers (DTCRs) are 8-bit readable/writable registers that control the operation of the DMAC channels. A channel operates in full address mode when bits DTS2A and DTS1A are both set to 1 in DTCRA. DTCRA and DTCRB have different functions in full address mode.

DTCRA

Bit	7	6	5	4	3	2	1	0
	DTE	DTSZ	SAID	SAIDE	DTIE	DTS2A	DTS1A	DTS0A
Initial value	0	0	0	0	0	0	0	0
Read/Write	R/W	R/W	R/W	R/W	R/W	R/W	R/W	R/W

<p>Data transfer enable Enables or disables data transfer</p>	<p>Data transfer size Selects byte or word size</p>	<p>Source address increment/decrement Source address increment/decrement enable These bits select whether the source address register (MARA) is incremented, decremented, or held fixed during the data transfer</p>	<p>Data transfer interrupt enable Enables or disables the CPU interrupt at the end of the transfer</p>	<p>Data transfer select 2A and 1A These bits must both be set to 1</p>
--	--	---	---	---

DTCRA is initialized to H'00 by a reset and in standby mode.

Bit 7—Data Transfer Enable (DTE): Together with the DTME bit in DTCRB, this bit enables or disables data transfer on the channel. When the DTME and DTE bits are both set to 1, the channel is enabled. If auto-request is specified, data transfer begins immediately. Otherwise, the channel waits for transfers to be requested. When the specified number of transfers have been completed, the DTE bit is automatically cleared to 0. When DTE is 0, the channel is disabled and does not accept transfer requests. DTE is set to 1 by reading the register when DTE is 0, then writing 1.

Bit 7

DTE	Description
0	Data transfer is disabled (DTE is cleared to 0 when the specified number (Initial value) of transfers have been completed)
1	Data transfer is enabled

If DTIE is set to 1, a CPU interrupt is requested when DTE is cleared to 0.

Bit 6—Data Transfer Size (DTSZ): Selects the data size of each transfer.

Bit 6

DTSZ	Description
0	Byte-size transfer (Initial value)
1	Word-size transfer

Bit 5—Source Address Increment/Decrement (SAID) and,

Bit 4—Source Address Increment/Decrement Enable (SAIDE): These bits select whether the source address register (MARA) is incremented, decremented, or held fixed during the data transfer.

Bit 5 SAID	Bit 4 SAIDE	Description
0	0	MARA is held fixed (Initial value)
	1	MARA is incremented after each data transfer <ul style="list-style-type: none"> • If DTSZ = 0, MARA is incremented by 1 after each transfer • If DTSZ = 1, MARA is incremented by 2 after each transfer
1	0	MARA is held fixed
	1	MARA is decremented after each data transfer <ul style="list-style-type: none"> • If DTSZ = 0, MARA is decremented by 1 after each transfer • If DTSZ = 1, MARA is decremented by 2 after each transfer

Bit 3—Data Transfer Interrupt Enable (DTIE): Enables or disables the CPU interrupt (DEND) requested when the DTE bit is cleared to 0.

Bit 3

DTIE	Description	
0	The DEND interrupt requested by DTE is disabled	(Initial value)
1	The DEND interrupt requested by DTE is enabled	

Bits 2 and 1—Data Transfer Select 2A and 1A (DTS2A, DTS1A): A channel operates in full address mode when DTS2A and DTS1A are both set to 1.

Bit 0—Data Transfer Select 0A (DTS0A): Selects normal mode or block transfer mode.

Bit 0

DTS0A	Description	
0	Normal mode	(Initial value)
1	Block transfer mode	

Operations in these modes are described in sections 7.4.5, Normal Mode, and 7.4.6, Block Transfer Mode.

DTCRB

Bit	7	6	5	4	3	2	1	0
	DTME	—	DAID	DAIDE	TMS	DTS2B	DTS1B	DTS0B
Initial value	0	0	0	0	0	0	0	0
Read/Write	R/W	R/W	R/W	R/W	R/W	R/W	R/W	R/W

Data transfer master enable
Enables or disables data transfer, together with the DTE bit, and is cleared to 0 by an interrupt

Reserved bit

Transfer mode select
Selects whether the block area is the source or destination in block transfer mode

**Destination address increment/decrement
Destination address increment/decrement enable**
These bits select whether the destination address register (MARB) is incremented, decremented, or held fixed during the data transfer

Data transfer select 2B to 0B
These bits select the data transfer activation source

DTCRB is initialized to H'00 by a reset and in standby mode.

Bit 7—Data Transfer Master Enable (DTME): Together with the DTE bit in DTCRA, this bit enables or disables data transfer. When the DTME and DTE bits are both set to 1, the channel is enabled. When an NMI interrupt occurs DTME is cleared to 0, suspending the transfer so that the CPU can use the bus. The suspended transfer resumes when DTME is set to 1 again. For further information on operation in block transfer mode, see section 7.6.6, NMI Interrupts and Block Transfer Mode.

DTME is set to 1 by reading the register while DTME = 0, then writing 1.

Bit 7

DTME	Description
0	Data transfer is disabled (DTME is cleared to 0 when an NMI interrupt occurs) (Initial value)
1	Data transfer is enabled

Bit 6—Reserved: Although reserved, this bit can be written and read.

Bit 5—Destination Address Increment/Decrement (DAID) and,

Bit 4—Destination Address Increment/Decrement Enable (DAIDE): These bits select whether the destination address register (MARB) is incremented, decremented, or held fixed during the data transfer.

Bit 5 DAID	Bit 4 DAIDE	Description
0	0	MARB is held fixed (Initial value)
	1	MARB is incremented after each data transfer <ul style="list-style-type: none"> • If DTSZ = 0, MARB is incremented by 1 after each data transfer • If DTSZ = 1, MARB is incremented by 2 after each data transfer
1	0	MARB is held fixed
	1	MARB is decremented after each data transfer <ul style="list-style-type: none"> • If DTSZ = 0, MARB is decremented by 1 after each data transfer • If DTSZ = 1, MARB is decremented by 2 after each data transfer

Bit 3—Transfer Mode Select (TMS): Selects whether the source or destination is the block area in block transfer mode.

Bit 3 TMS	Description
0	Destination is the block area in block transfer mode (Initial value)
1	Source is the block area in block transfer mode

Bits 2 to 0—Data Transfer Select 2B to 0B (DTS2B, DTS1B, DTS0B): These bits select the data transfer activation source. The selectable activation sources differ between normal mode and block transfer mode.

Normal mode

Bit 2 DTS2B	Bit 1 DTS1B	Bit 0 DTS0B	Description
0	0	0	Auto-request (burst mode) (Initial value)
		1	Cannot be used
	1	0	Auto-request (cycle-steal mode)
		1	Cannot be used
1	0	0	Cannot be used
		1	Cannot be used
	1	0	Falling edge of \overline{DREQ}
		1	Low level input at \overline{DREQ}

Block transfer mode

Bit 2 DTS2B	Bit 1 DTS1B	Bit 0 DTS0B	Description
0	0	0	Compare match/input capture A interrupt from 16-bit timer channel 0 (Initial value)
		1	Compare match/input capture A interrupt from 16-bit timer channel 1
	1	0	Compare match/input capture A interrupt from 16-bit timer channel 2
		1	Conversion-end interrupt from A/D converter
1	0	0	Cannot be used
		1	Cannot be used
	1	0	Falling edge of \overline{DREQ}
		1	Cannot be used

The same internal interrupt can be selected to activate two or more channels. The channels are activated in a priority order, highest priority first. For the priority order, see section 7.4.9, Multiple-Channel Operation.

7.4 Operation

7.4.1 Overview

Table 7.5 summarizes the DMAC modes.

Table 7.5 DMAC Modes

Transfer Mode		Activation	Notes
Short address mode	I/O mode	Compare match/input capture A interrupt from 16-bit timer channels 0 to 2	<ul style="list-style-type: none"> Up to four channels can operate independently Only the B channels support external requests
	Idle mode	Transmit-data-empty and receive-data-full interrupts from SCI channel 0	
	Repeat mode	Conversion-end interrupt from A/D converter	
		External request	
Full address mode	Normal mode	Auto-request	<ul style="list-style-type: none"> A and B channels are paired; up to two channels are available Burst mode transfer or cycle-steal mode transfer can be selected for auto-requests
		External request	
	Block transfer mode	Compare match/input capture A interrupt from 16-bit timer channels 0 to 2	
		Conversion-end interrupt from A/D converter	
	External request		

A summary of operations in these modes follows.

I/O Mode: One byte or word is transferred per request. A designated number of these transfers are executed. A CPU interrupt can be requested at completion of the designated number of transfers. One 24-bit address and one 8-bit address are specified. The transfer direction is determined automatically from the activation source.

Idle Mode: One byte or word is transferred per request. A designated number of these transfers are executed. A CPU interrupt can be requested at completion of the designated number of transfers. One 24-bit address and one 8-bit address are specified. The addresses are held fixed. The transfer direction is determined automatically from the activation source.

Repeat Mode: One byte or word is transferred per request. A designated number of these transfers are executed. When the designated number of transfers are completed, the initial address and counter value are restored and operation continues. No CPU interrupt is requested. One 24-bit address and one 8-bit address are specified. The transfer direction is determined automatically from the activation source.

Normal Mode

- Auto-request

The DMAC is activated by register setup alone, and continues executing transfers until the designated number of transfers have been completed. A CPU interrupt can be requested at completion of the transfers. Both addresses are 24-bit addresses.

- Cycle-steal mode

The bus is released to another bus master after each byte or word is transferred.

- Burst mode

Unless requested by a higher-priority bus master, the bus is not released until the designated number of transfers have been completed.

- External request

One byte or word is transferred per request. A designated number of these transfers are executed. A CPU interrupt can be requested at completion of the designated number of transfers. Both addresses are 24-bit addresses.

Block Transfer Mode: One block of a specified size is transferred per request. A designated number of block transfers are executed. At the end of each block transfer, one address is restored to its initial value. When the designated number of blocks have been transferred, a CPU interrupt can be requested. Both addresses are 24-bit addresses.



7.4.2 I/O Mode

I/O mode can be selected independently for each channel.

One byte or word is transferred at each transfer request in I/O mode. A designated number of these transfers are executed. One address is specified in the memory address register (MAR), the other in the I/O address register (IOAR). The direction of transfer is determined automatically from the activation source. The transfer is from the address specified in IOAR to the address specified in MAR if activated by an SCI channel 0 receive-data-full interrupt, and from the address specified in MAR to the address specified in IOAR otherwise.

Table 7.6 indicates the register functions in I/O mode.

Table 7.6 Register Functions in I/O Mode

Register	Function		Initial Setting	Operation
	Activated by SCI 0 Receive- Data-Full Interrupt	Other Activation		
23 0 	Destination address register	Source address register	Destination or source start address	Incremented or decremented once per transfer
23 7 0 	Source address register	Destination address register	Source or destination address	Held fixed
15 0 	Transfer counter		Number of transfers	Decrementd once per transfer until H'0000 is reached and transfer ends

Legend

MAR: Memory address register

IOAR: I/O address register

ETCR: Execute transfer count register

MAR and IOAR specify the source and destination addresses. MAR specifies a 24-bit source or destination address, which is incremented or decremented as each byte or word is transferred. IOAR specifies the lower 8 bits of a fixed address. The upper 16 bits are all 1s. IOAR is not incremented or decremented.

Figure 7.2 illustrates how I/O mode operates.

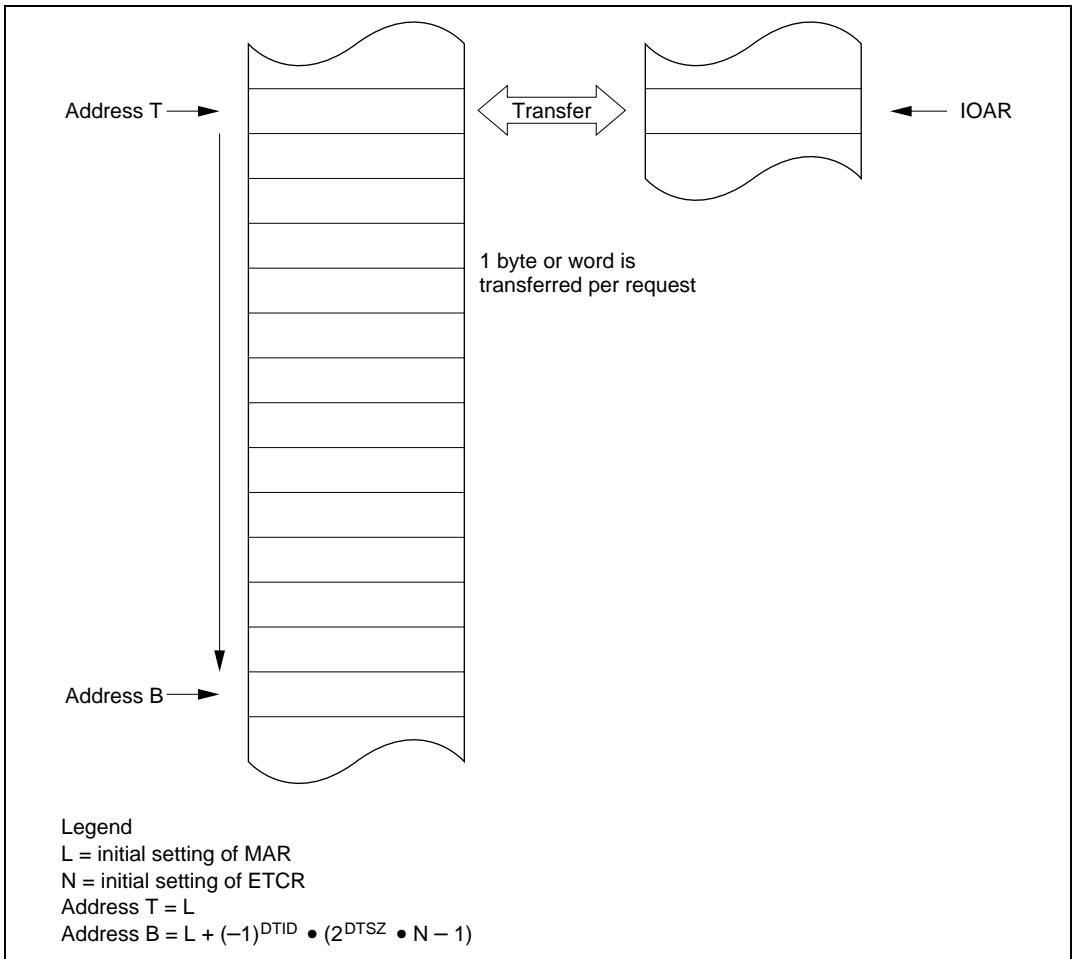

Figure 7.2 Operation in I/O Mode

The transfer count is specified as a 16-bit value in ETCR. The ETCR value is decremented by 1 at each transfer. When the ETCR value reaches H'0000, the DTE bit is cleared and the transfer ends. If the DTIE bit is set to 1, a CPU interrupt is requested at this time. The maximum transfer count is 65,536, obtained by setting ETCR to H'0000.

Transfers can be requested (activated) by compare match/input capture A interrupts from 16-bit timer channels 0 to 2, transmit-data-empty and receive-data-full interrupts from SCI channel 0, conversion-end interrupts from the A/D converter, and external request signals.

For the detailed settings see section 7.2.4, Data Transfer Control Registers (DTCR).

Figure 7.3 shows a sample setup procedure for I/O mode.

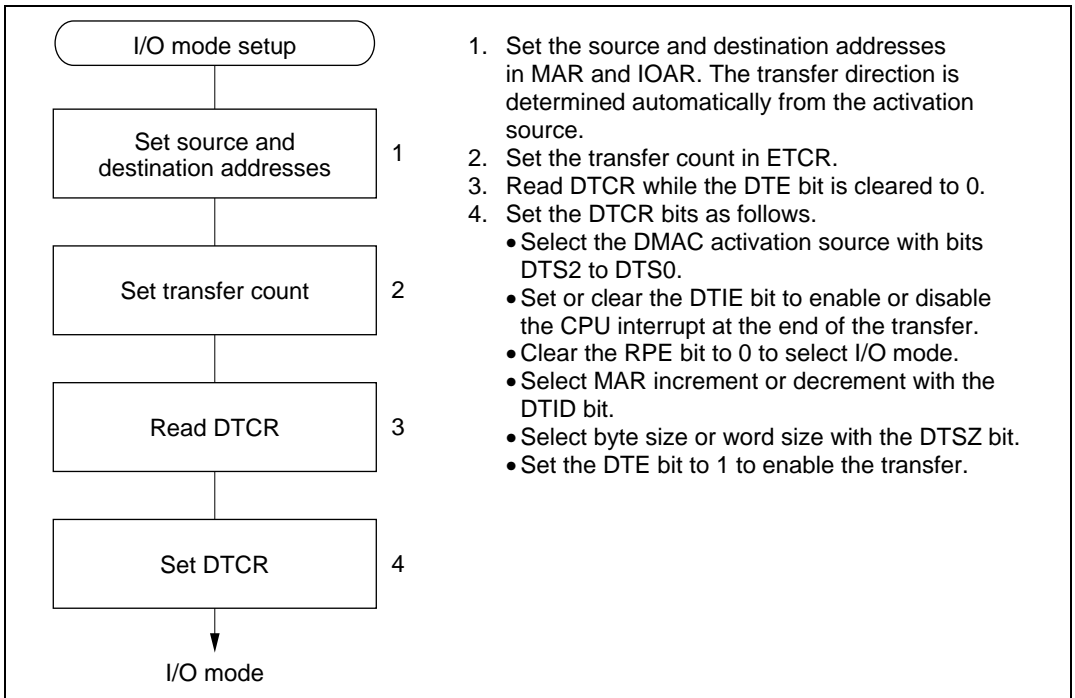

Figure 7.3 I/O Mode Setup Procedure (Example)



7.4.3 Idle Mode

Idle mode can be selected independently for each channel.

One byte or word is transferred at each transfer request in idle mode. A designated number of these transfers are executed. One address is specified in the memory address register (MAR), the other in the I/O address register (IOAR). The direction of transfer is determined automatically from the activation source. The transfer is from the address specified in IOAR to the address specified in MAR if activated by an SCI channel 0 receive-data-full interrupt, and from the address specified in MAR to the address specified in IOAR otherwise.

Table 7.7 indicates the register functions in idle mode.

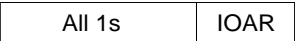
Table 7.7 Register Functions in Idle Mode

Register	Function		Initial Setting	Operation
	Activated by SCI 0 Receive- Data-Full Interrupt	Other Activation		
23 0 	Destination address register	Source address register	Destination or source address	Held fixed
23 7 0 	Source address register	Destination address register	Source or destination address	Held fixed
15 0 	Transfer counter		Number of transfers	Decrement once per transfer until H'0000 is reached and transfer ends

Legend

MAR: Memory address register

IOAR: I/O address register

ETCR: Execute transfer count register

MAR and IOAR specify the source and destination addresses. MAR specifies a 24-bit source or destination address. IOAR specifies the lower 8 bits of a fixed address. The upper 16 bits are all 1s. MAR and IOAR are not incremented or decremented.

Figure 7.4 illustrates how idle mode operates.

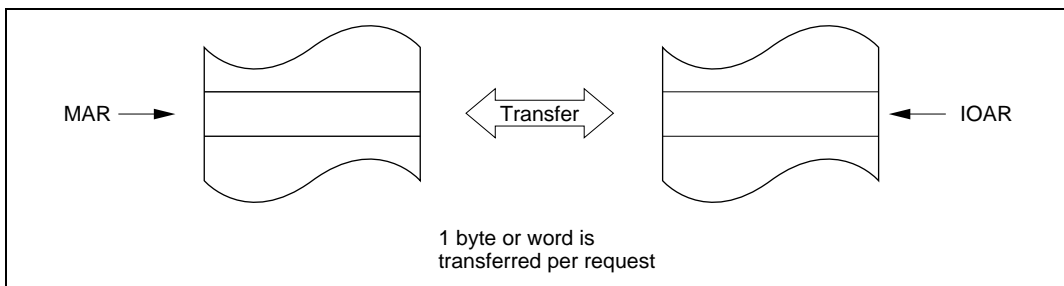
**Figure 7.4 Operation in Idle Mode**

The transfer count is specified as a 16-bit value in ETCR. The ETCR value is decremented by 1 at each transfer. When the ETCR value reaches H'0000, the DTE bit is cleared, the transfer ends, and a CPU interrupt is requested. The maximum transfer count is 65,536, obtained by setting ETCR to H'0000.

Transfers can be requested (activated) by compare match/input capture A interrupts from 16-bit timer channels 0 to 2, transmit-data-empty and receive-data-full interrupts from SCI channel 0, conversion-end interrupts from the A/D converter, and external request signals.

For the detailed settings see section 7.3.4, Data Transfer Control Registers (DTCR).

Figure 7.5 shows a sample setup procedure for idle mode.

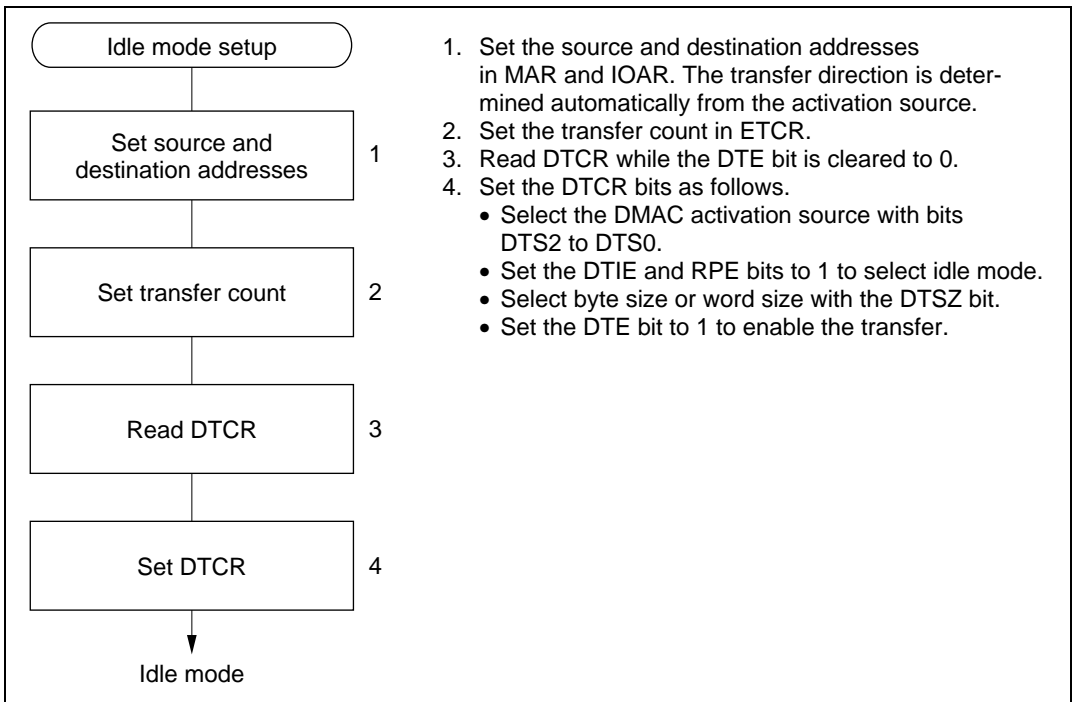

Figure 7.5 Idle Mode Setup Procedure (Example)



7.4.4 Repeat Mode

Repeat mode is useful for cyclically transferring a bit pattern from a table to the programmable timing pattern controller (TPC) in synchronization, for example, with 16-bit timer compare match. Repeat mode can be selected for each channel independently.

One byte or word is transferred per request in repeat mode, as in I/O mode. A designated number of these transfers are executed. One address is specified in the memory address register (MAR), the other in the I/O address register (IOAR). At the end of the designated number of transfers, MAR and ETCRH are restored to their original values and operation continues. The direction of transfer is determined automatically from the activation source. The transfer is from the address specified in IOAR to the address specified in MAR if activated by an SCI channel 0 receive-data-full interrupt, and from the address specified in MAR to the address specified in IOAR otherwise.

Table 7.8 indicates the register functions in repeat mode.

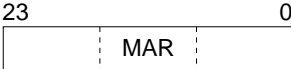
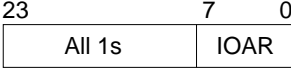
Table 7.8 Register Functions in Repeat Mode

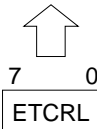
Register	Function		Initial Setting	Operation
	Activated by SCI 0 Receive-Data-Full Interrupt	Other Activation		
	Destination address register	Source address register	Destination or source start address	Incremented or decremented at each transfer until ETCRH reaches H'0000, then restored to initial value
	Source address register	Destination address register	Source or destination address	Held fixed
	Transfer counter		Number of transfers	Decrementd once per transfer until H'0000 is reached, then reloaded from ETCRL
	Initial transfer count		Number of transfers	Held fixed

Legend

MAR: Memory address register

IOAR: I/O address register

ETCR: Execute transfer count register

In repeat mode ETCRH is used as the transfer counter while ETCRL holds the initial transfer count. ETCRH is decremented by 1 at each transfer until it reaches H'00, then is reloaded from ETCRL. MAR is also restored to its initial value, which is calculated from the DTSZ and DTID bits in DTCR. Specifically, MAR is restored as follows:

$$\text{MAR} \leftarrow \text{MAR} - (-1)^{\text{DTID}} \cdot 2^{\text{DTSZ}} \cdot \text{ETCRL}$$

ETCRH and ETCRL should be initially set to the same value.

In repeat mode transfers continue until the CPU clears the DTE bit to 0. After DTE is cleared to 0, if the CPU sets DTE to 1 again, transfers resume from the state at which DTE was cleared. No CPU interrupt is requested.

As in I/O mode, MAR and IOAR specify the source and destination addresses. MAR specifies a 24-bit source or destination address. IOAR specifies the lower 8 bits of a fixed address. The upper 16 bits are all 1s. IOAR is not incremented or decremented.

Figure 7.6 illustrates how repeat mode operates.

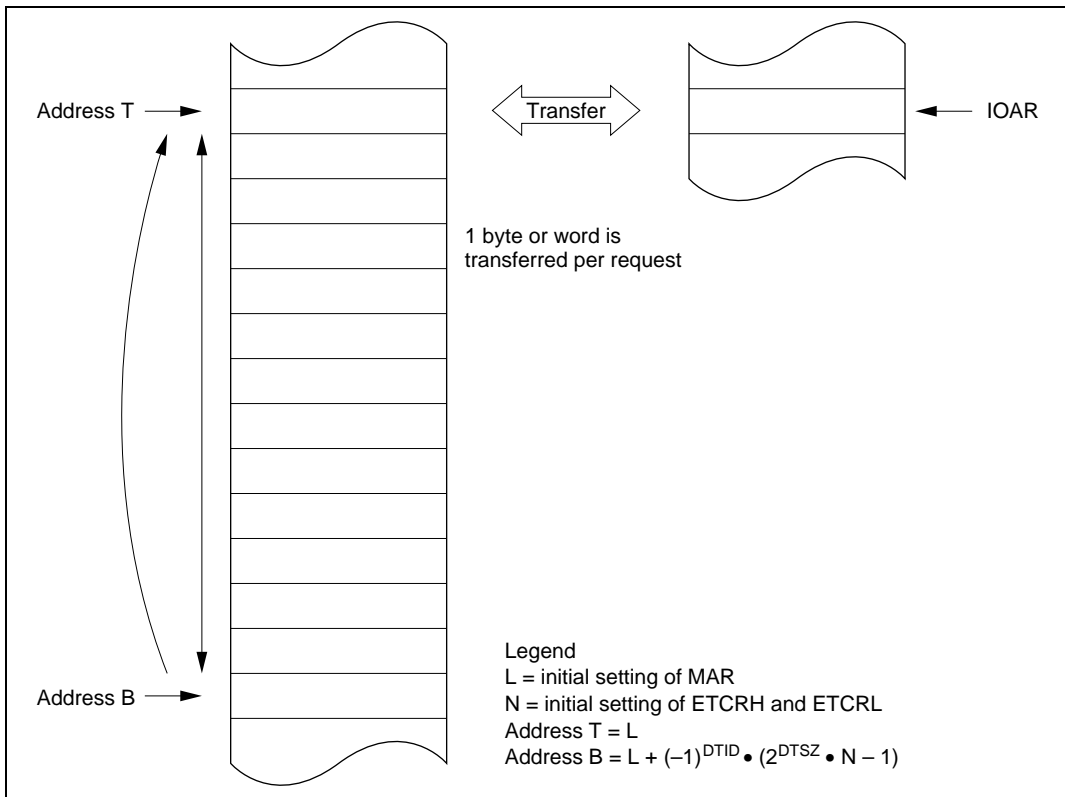

Figure 7.6 Operation in Repeat Mode

The transfer count is specified as an 8-bit value in ETCRH and ETCRL. The maximum transfer count is 255, obtained by setting both ETCRH and ETCRL to H'FF.

Transfers can be requested (activated) by compare match/input capture A interrupts from 16-bit timer channels 0 to 2, transmit-data-empty and receive-data-full interrupts from SCI channel 0, conversion-end interrupts from the A/D converter, and external request signals.

For the detailed settings see section 7.2.4, Data Transfer Control Registers (DTCR).

Figure 7.7 shows a sample setup procedure for repeat mode.

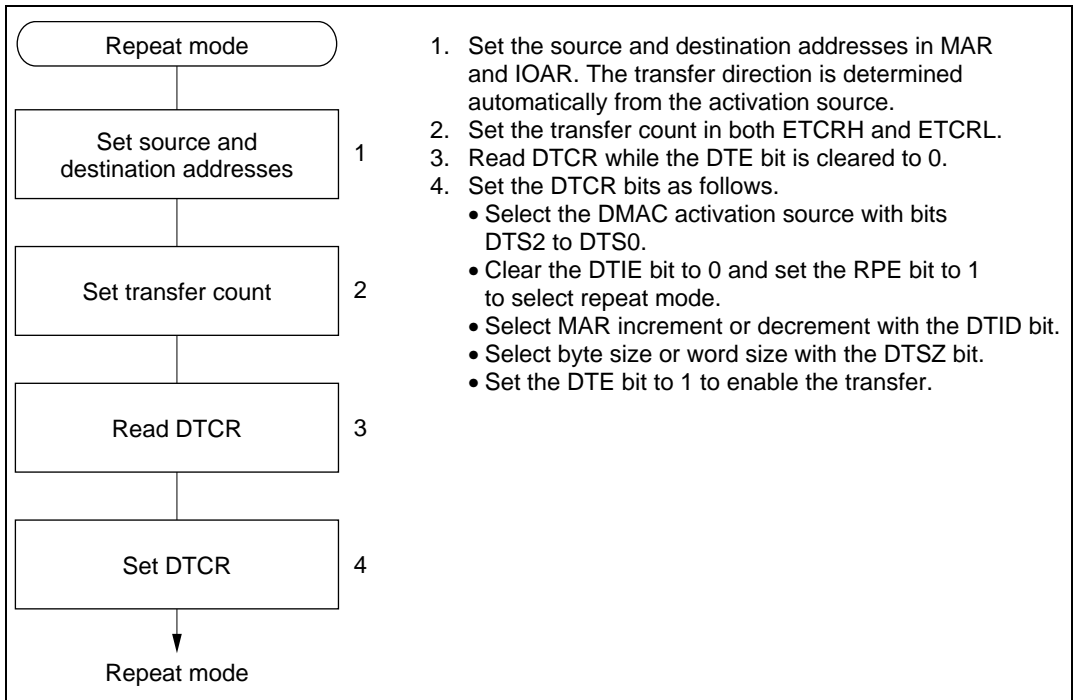





Figure 7.7 Repeat Mode Setup Procedure (Example)

7.4.5 Normal Mode

In normal mode the A and B channels are combined. One byte or word is transferred per request. A designated number of these transfers are executed. Addresses are specified in MARA and MARB. Table 7.9 indicates the register functions in I/O mode.

Table 7.9 Register Functions in Normal Mode

Register	Function	Initial Setting	Operation
23 	0 Source address register	Source start address	Incremented or decremented once per transfer, or held fixed
23 	0 Destination address register	Destination start address	Incremented or decremented once per transfer, or held fixed
15 	0 Transfer counter	Number of transfers	Decrementd once per transfer

Legend

MARA: Memory address register A

MARB: Memory address register B

ETCRA: Execute transfer count register A

The source and destination addresses are both 24-bit addresses. MARA specifies the source address. MARB specifies the destination address. MARA and MARB can be independently incremented, decremented, or held fixed as data is transferred.

The transfer count is specified as a 16-bit value in ETCRA. The ETCRA value is decremented by 1 at each transfer. When the ETCRA value reaches H'0000, the DTE bit is cleared and the transfer ends. If the DTIE bit is set to 1, a CPU interrupt is requested at this time. The maximum transfer count is 65,536, obtained by setting ETCRA to H'0000.

Figure 7.8 illustrates how normal mode operates.

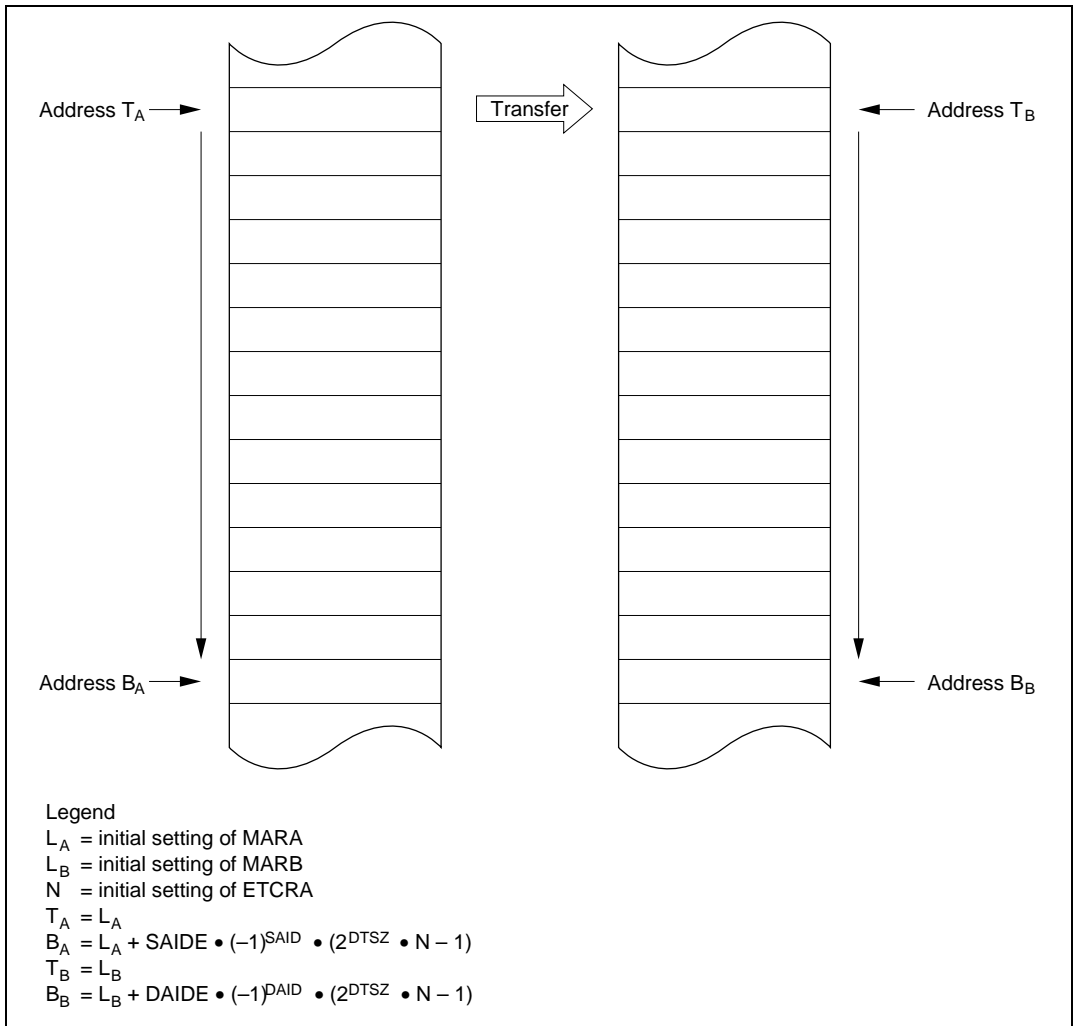

Figure 7.8 Operation in Normal Mode

Transfers can be requested (activated) by an external request or auto-request. An auto-requested transfer is activated by the register settings alone. The designated number of transfers are executed automatically. Either cycle-steal or burst mode can be selected. In cycle-steal mode the DMAC releases the bus temporarily after each transfer. In burst mode the DMAC keeps the bus until the transfers are completed, unless there is a bus request from a higher-priority bus master.

For the detailed settings see section 7.3.4, Data Transfer Control Registers (DTCR).

Figure 7.9 shows a sample setup procedure for normal mode.

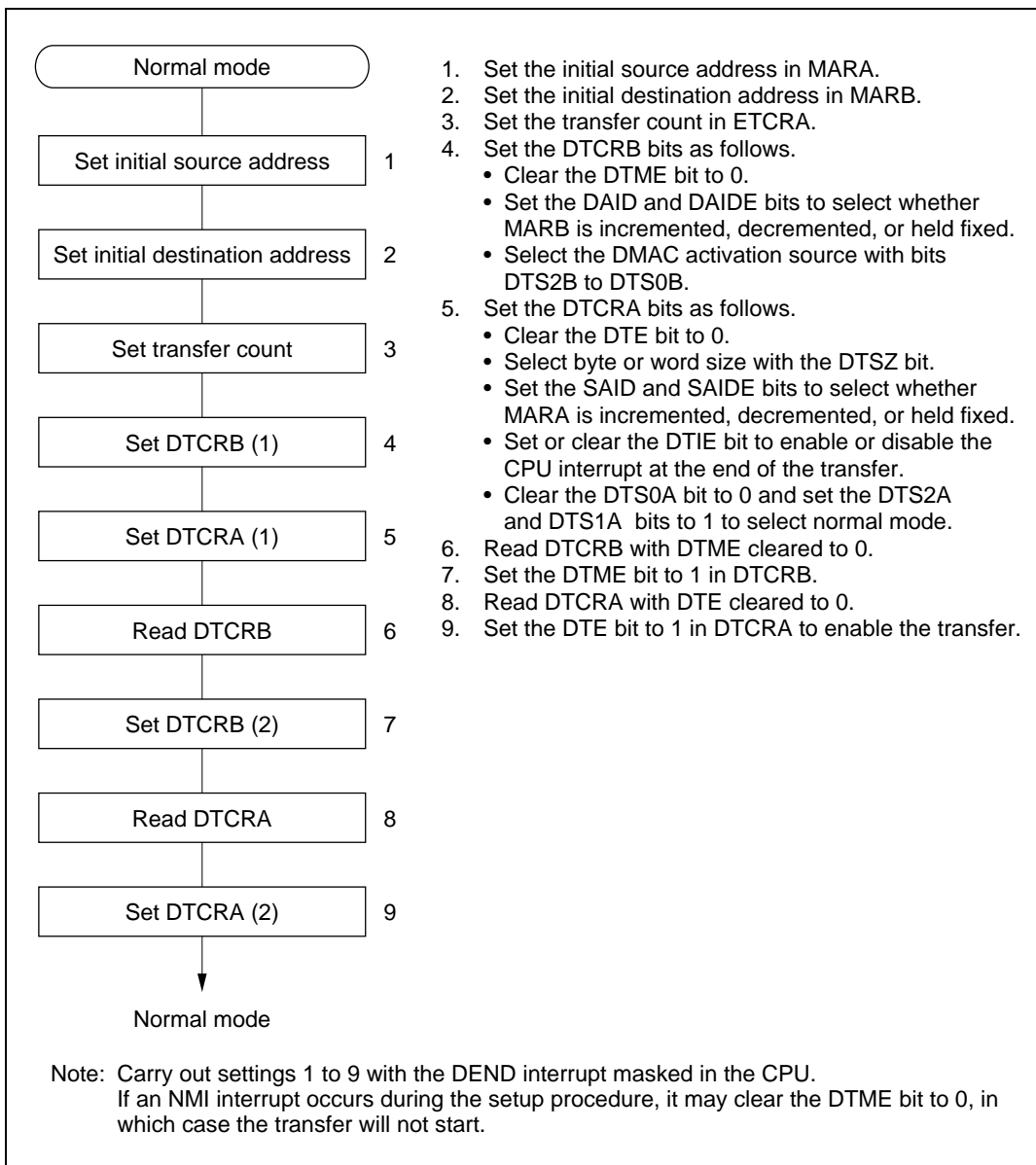







Figure 7.9 Normal Mode Setup Procedure (Example)

7.4.6 Block Transfer Mode

In block transfer mode the A and B channels are combined. One block of a specified size is transferred per request. A designated number of block transfers are executed. Addresses are specified in MARA and MARB. The block area address can be either held fixed or cycled.

Table 7.10 indicates the register functions in block transfer mode.

Table 7.10 Register Functions in Block Transfer Mode

Register	Function	Initial Setting	Operation
23 0 	Source address register	Source start address	Incremented or decremented once per transfer, or held fixed
23 0 	Destination address register	Destination start address	Incremented or decremented once per transfer, or held fixed
7 0 	Block size counter	Block size	Decrementd once per transfer until H'00 is reached, then reloaded from ETCRL
7 0 	Initial block size	Block size	Held fixed
15 0 	Block transfer counter	Number of block transfers	Decrementd once per block transfer until H'0000 is reached and the transfer ends

Legend

MARA: Memory address register A

MARB: Memory address register B

ETCRA: Execute transfer count register A

ETCRB: Execute transfer count register B

The source and destination addresses are both 24-bit addresses. MARA specifies the source address. MARB specifies the destination address. MARA and MARB can be independently incremented, decremented, or held fixed as data is transferred. One of these registers operates as a block area register: even if it is incremented or decremented, it is restored to its initial value at the end of each block transfer. The TMS bit in DTCRB selects whether the block area is the source or destination.

If M (1 to 255) is the size of the block transferred at each request and N (1 to 65,536) is the number of blocks to be transferred, then ETCRAH and ETCRAL should initially be set to M and ETCRB should initially be set to N .

Figure 7.10 illustrates how block transfer mode operates. In this figure, bit TMS is cleared to 0, meaning the block area is the destination.

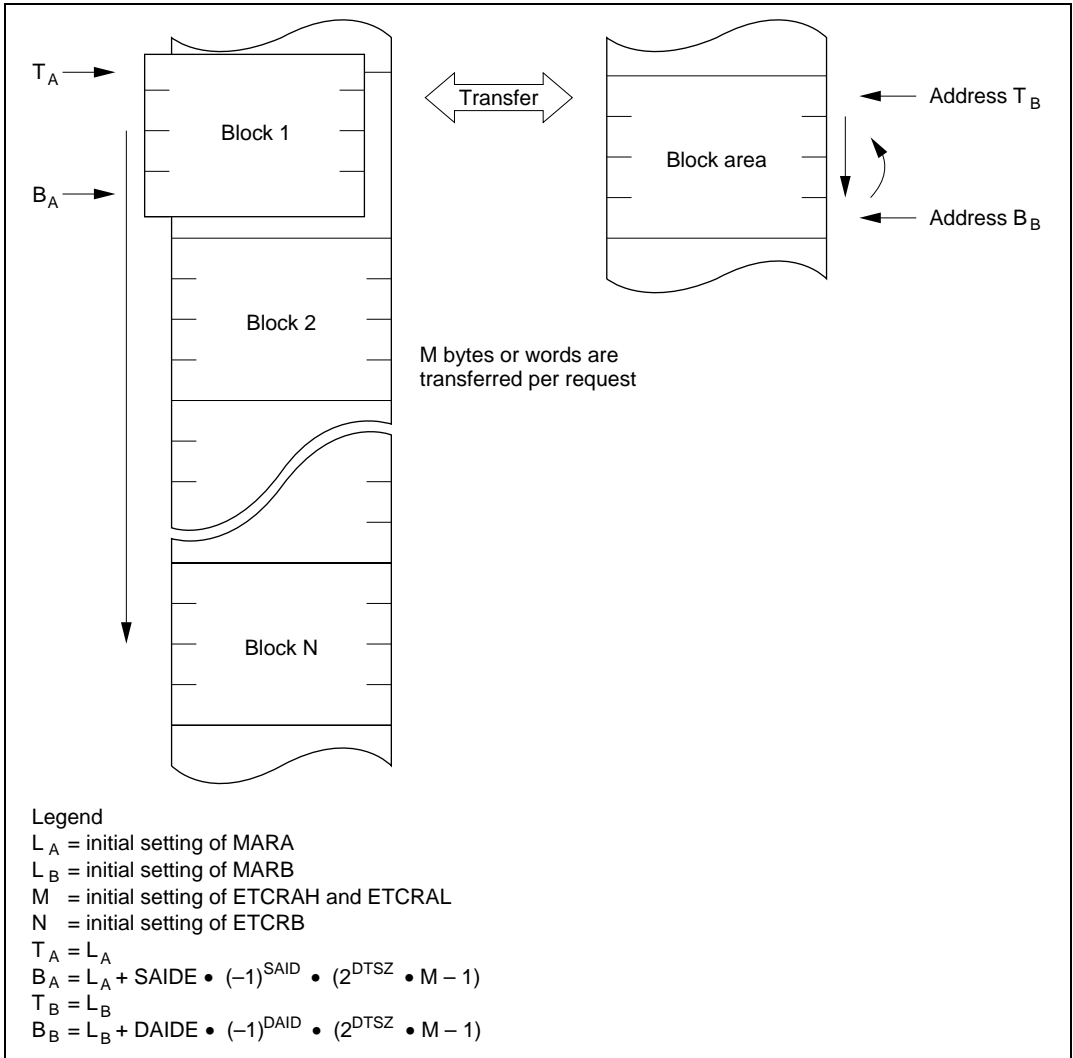

Figure 7.10 Operation in Block Transfer Mode

When activated by a transfer request, the DMAC executes a burst transfer. During the transfer MARA and MARB are updated according to the DTCR settings, and ETCRAH is decremented. When ETCRAH reaches H'00, it is reloaded from ETCRAL to restore the initial value. The memory address register of the block area is also restored to its initial value, and ETCRB is decremented. If ETCRB is not H'0000, the DMAC then waits for the next transfer request. ETCRAH and ETCRAL should be initially set to the same value.

The above operation is repeated until ETCRB reaches H'0000, at which point the DTE bit is cleared to 0 and the transfer ends. If the DTIE bit is set to 1, a CPU interrupt is requested at this time.

Figure 7.11 shows examples of a block transfer with byte data size when the block area is the destination. In (a) the block area address is cycled. In (b) the block area address is held fixed.

Transfers can be requested (activated) by compare match/input capture A interrupts from ITU channels 0 to 2, by an A/D converter conversion-end interrupt, and by external request signals.

For the detailed settings see section 7.3.4, Data Transfer Control Registers (DTCR).

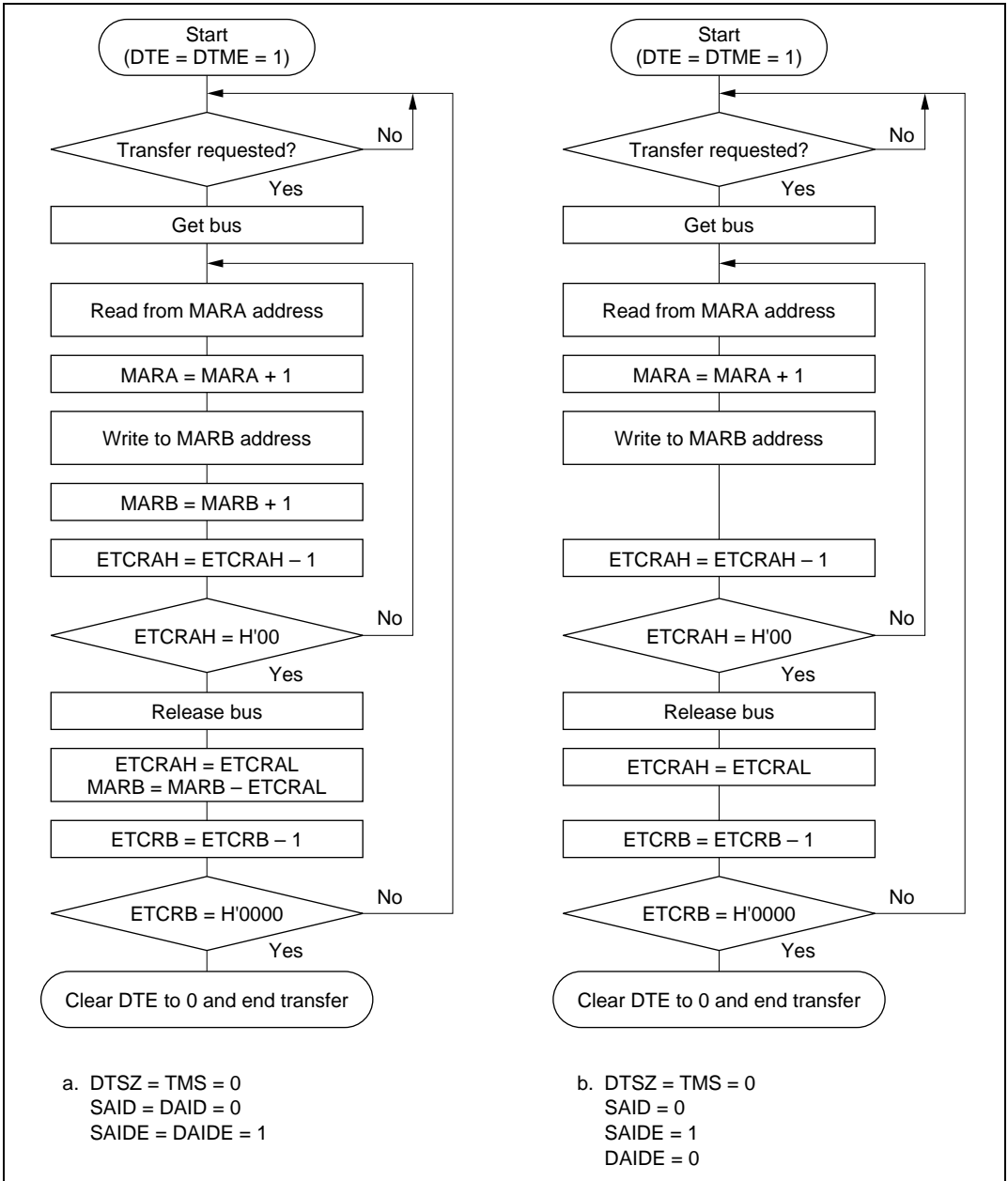

Figure 7.11 Block Transfer Mode Flowcharts (Examples)

Figure 7.12 shows a sample setup procedure for block transfer mode.

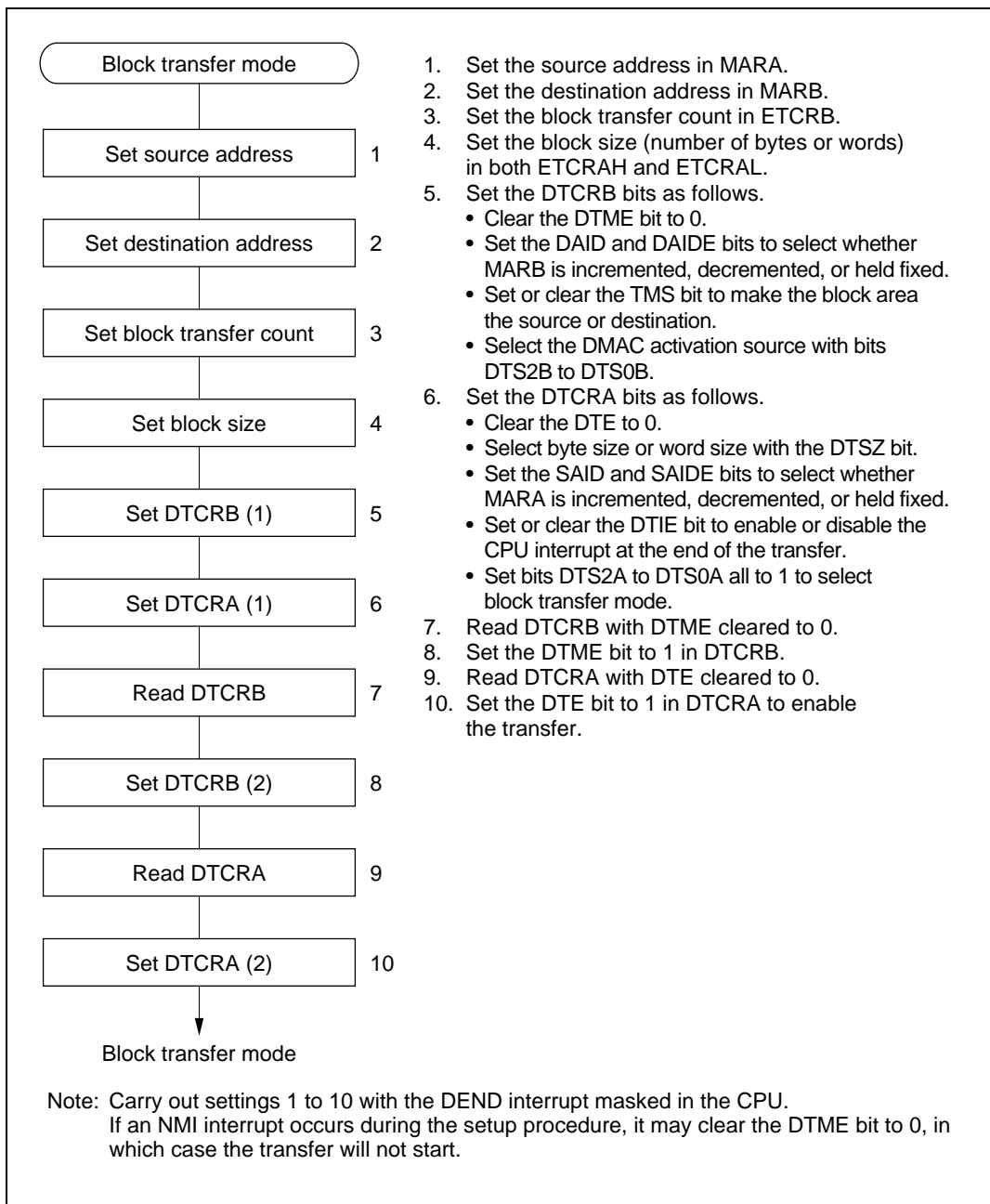

Figure 7.12 Block Transfer Mode Setup Procedure (Example)

7.4.7 DMAC Activation

The DMAC can be activated by an internal interrupt, external request, or auto-request. The available activation sources differ depending on the transfer mode and channel as indicated in table 7.11.

Table 7.11 DMAC Activation Sources

Activation Source		Short Address Mode		Full Address Mode	
		Channels	Channels	Normal	Block
		0A and 1A	0B and 1B		
Internal interrupts	IMIA0	○	○	×	○
	IMIA1	○	○	×	○
	IMIA2	○	○	×	○
	ADI	○	○	×	○
	TXI0	○	○	×	×
	RXI0	○	○	×	×
External requests	Falling edge of $\overline{\text{DREQ}}$	×	○	○	○
	Low input at $\overline{\text{DREQ}}$	×	○	○	×
Auto-request		×	×	○	×

Activation by Internal Interrupts: When an interrupt request is selected as a DMAC activation source and the DTE bit is set to 1, that interrupt request is not sent to the CPU. It is not possible for an interrupt request to activate the DMAC and simultaneously generate a CPU interrupt.

When the DMAC is activated by an interrupt request, the interrupt request flag is cleared automatically. If the same interrupt is selected to activate two or more channels, the interrupt request flag is cleared when the highest-priority channel is activated, but the transfer request is held pending on the other channels in the DMAC, which are activated in their priority order.

Activation by External Request: If an external request ($\overline{\text{DREQ}}$ pin) is selected as an activation source, the $\overline{\text{DREQ}}$ pin becomes an input pin and the corresponding $\overline{\text{TEND}}$ pin becomes an output pin, regardless of the port data direction register (DDR) settings. The $\overline{\text{DREQ}}$ input can be level-sensitive or edge-sensitive.

In short address mode and normal mode, an external request operates as follows. If edge sensing is selected, one byte or word is transferred each time a high-to-low transition of the $\overline{\text{DREQ}}$ input is detected. If the next edge is input before the transfer is completed, the next transfer may not be executed. If level sensing is selected, the transfer continues while $\overline{\text{DREQ}}$ is low, until the transfer is completed. The bus is released temporarily after each byte or word has been transferred, however. If the $\overline{\text{DREQ}}$ input goes high during a transfer, the transfer is suspended after the current byte or word has been transferred. When $\overline{\text{DREQ}}$ goes low, the request is held internally until one byte or word has been transferred. The $\overline{\text{TEND}}$ signal goes low during the last write cycle.

In block transfer mode, an external request operates as follows. Only edge-sensitive transfer requests are possible in block transfer mode. Each time a high-to-low transition of the $\overline{\text{DREQ}}$ input is detected, a block of the specified size is transferred. The $\overline{\text{TEND}}$ signal goes low during the last write cycle in each block.

Activation by Auto-Request: The transfer starts as soon as enabled by register setup, and continues until completed. Cycle-steal mode or burst mode can be selected.

In cycle-steal mode the DMAC releases the bus temporarily after transferring each byte or word. Normally, DMAC cycles alternate with CPU cycles.

In burst mode the DMAC keeps the bus until the transfer is completed, unless there is a higher-priority bus request. If there is a higher-priority bus request, the bus is released after the current byte or word has been transferred.

7.4.8 DMAC Bus Cycle

Figure 7.13 shows an example of the timing of the basic DMAC bus cycle. This example shows a word-size transfer from a 16-bit two-state access area to an 8-bit three-state access area. When the DMAC gets the bus from the CPU, after one dead cycle (T_d), it reads from the source address and writes to the destination address. During these read and write operations the bus is not released even if there is another bus request. DMAC cycles comply with bus controller settings in the same way as CPU cycles.

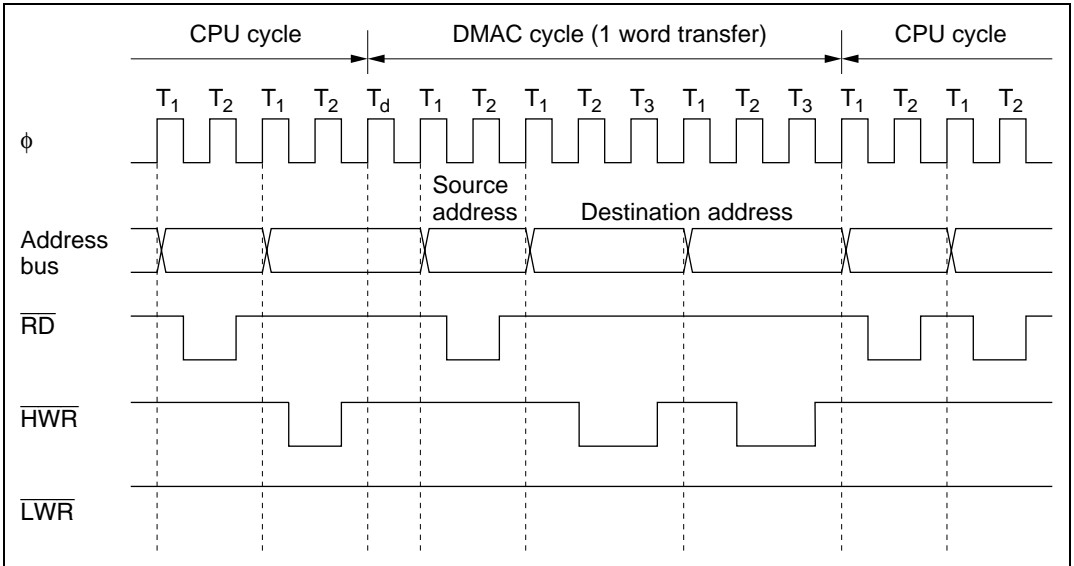

Figure 7.13 DMA Transfer Bus Timing (Example)

Figure 7.14 shows the timing when the DMAC is activated by low input at a $\overline{\text{DREQ}}$ pin. This example shows a word-size transfer from a 16-bit two-state access area to another 16-bit two-state access area. The DMAC continues the transfer while the $\overline{\text{DREQ}}$ pin is held low.

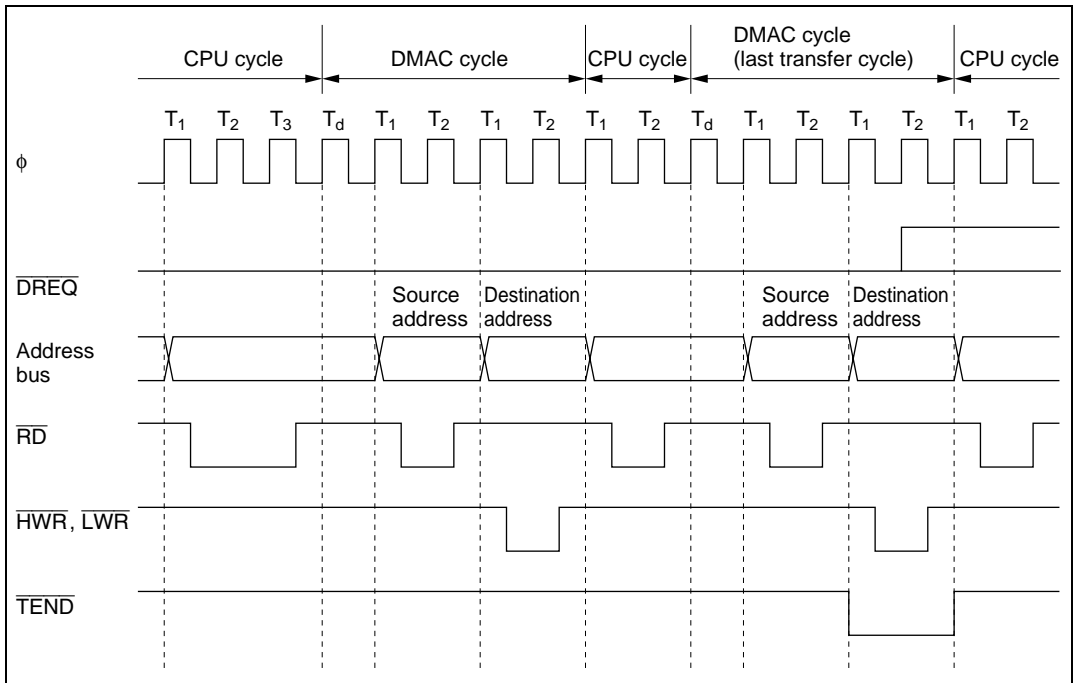

Figure 7.14 Bus Timing of DMA Transfer Requested by Low $\overline{\text{DREQ}}$ Input

Figure 7.15 shows an auto-requested burst-mode transfer. This example shows a transfer of three words from a 16-bit two-state access area to another 16-bit two-state access area.

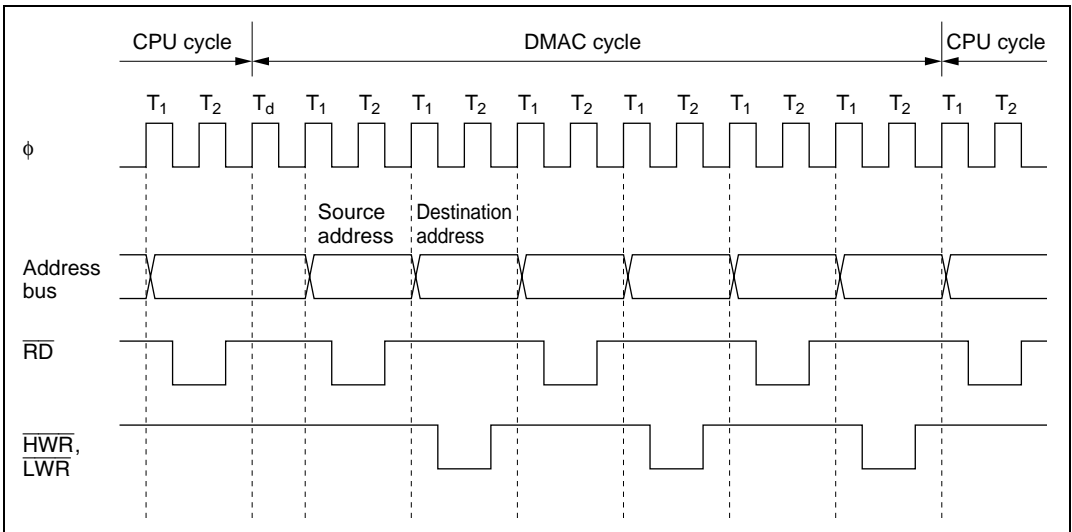

Figure 7.15 Burst DMA Bus Timing

When the DMAC is activated from a \overline{DREQ} pin there is a minimum interval of four states from when the transfer is requested until the DMAC starts operating. The \overline{DREQ} pin is not sampled during the time between the transfer request and the start of the transfer. In short address mode and normal mode, the pin is next sampled at the end of the read cycle. In block transfer mode, the pin is next sampled at the end of one block transfer.

Figure 7.16 shows the timing when the DMAC is activated by the falling edge of $\overline{\text{DREQ}}$ in normal mode.

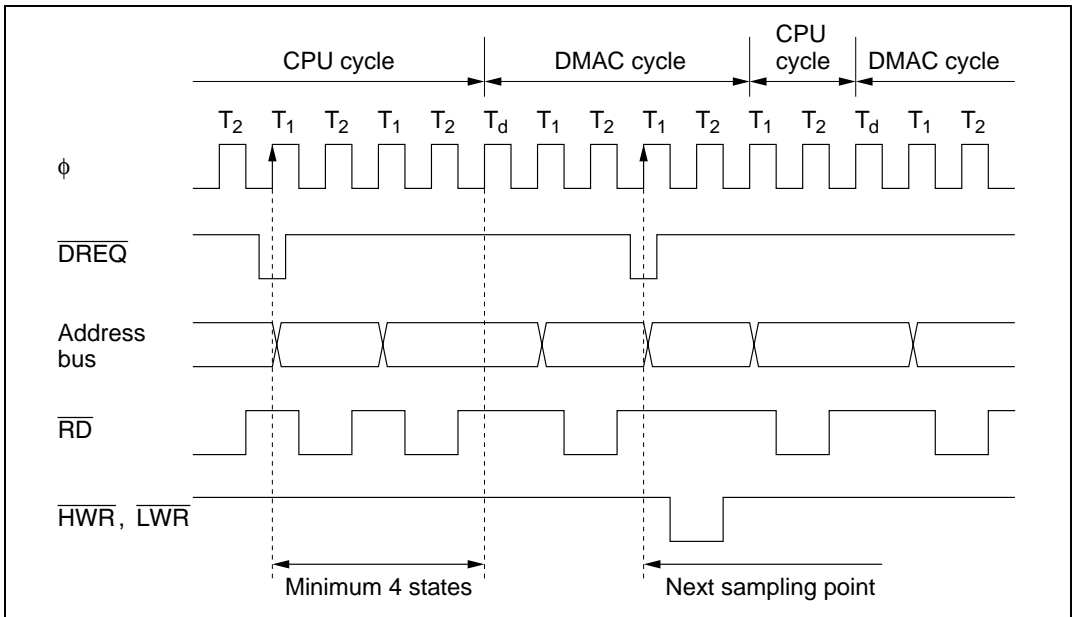

Figure 7.16 Timing of DMAC Activation by Falling Edge of $\overline{\text{DREQ}}$ in Normal Mode

Figure 7.17 shows the timing when the DMAC is activated by level-sensitive low $\overline{\text{DREQ}}$ input in normal mode.

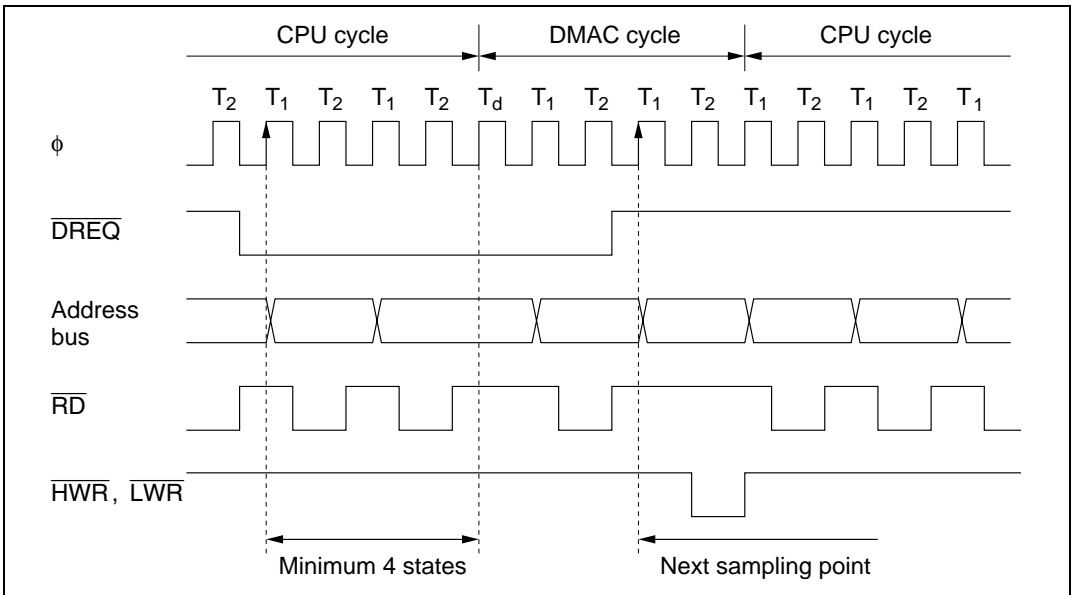

Figure 7.17 Timing of DMAC Activation by Low $\overline{\text{DREQ}}$ Level in Normal Mode

Figure 7.18 shows the timing when the DMAC is activated by the falling edge of $\overline{\text{DREQ}}$ in block transfer mode.

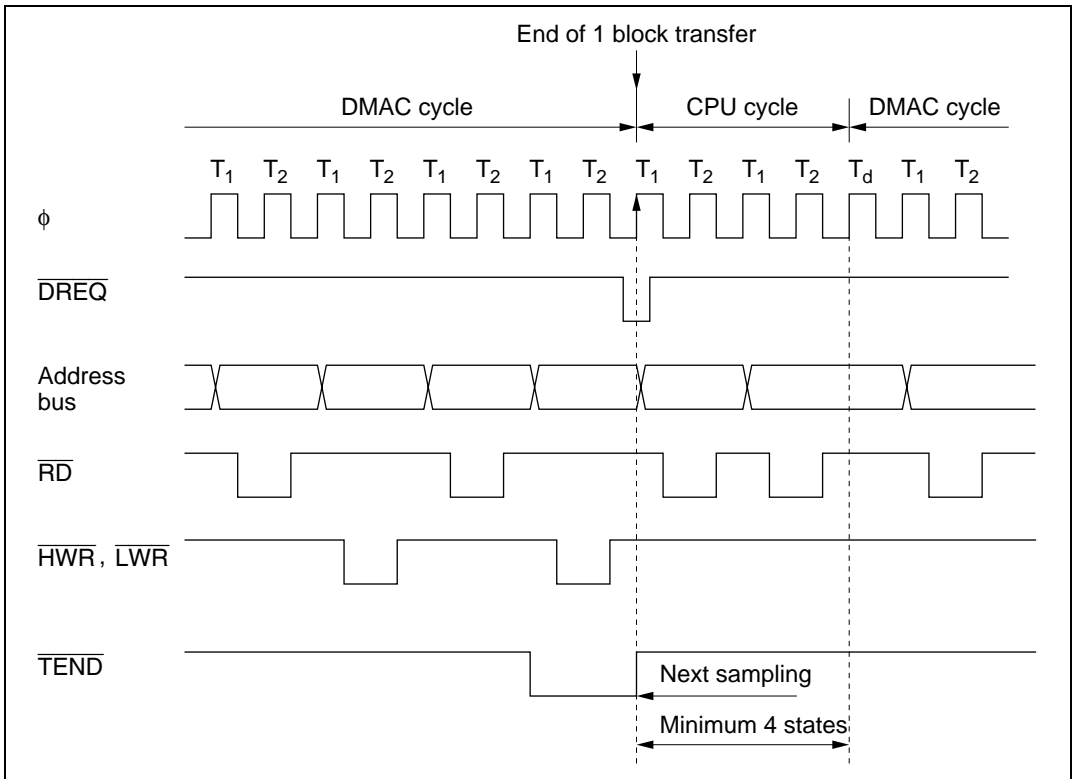

Figure 7.18 Timing of DMAC Activation by Falling Edge of $\overline{\text{DREQ}}$ in Block Transfer Mode

7.4.9 Multiple-Channel Operation

The DMAC channel priority order is: channel 0 > channel 1 and channel A > channel B.

Table 7.12 shows the complete priority order.

Table 7.12 Channel Priority Order

Short Address Mode	Full Address Mode	Priority
Channel 0A	Channel 0	High
Channel 0B		↑
Channel 1A	Channel 1	↓
Channel 1B		Low

If transfers are requested on two or more channels simultaneously, or if a transfer on one channel is requested during a transfer on another channel, the DMAC operates as follows.

- When a transfer is requested, the DMAC requests the bus right. When it gets the bus right, it starts a transfer on the highest-priority channel at that time.
- Once a transfer starts on one channel, requests to other channels are held pending until that channel releases the bus.
- After each transfer in short address mode, and each externally-requested or cycle-steal transfer in normal mode, the DMAC releases the bus and returns to step 1. After releasing the bus, if there is a transfer request for another channel, the DMAC requests the bus again.
- After completion of a burst-mode transfer, or after transfer of one block in block transfer mode, the DMAC releases the bus and returns to step 1. If there is a transfer request for a higher-priority channel or a bus request from a higher-priority bus master, however, the DMAC releases the bus after completing the transfer of the current byte or word. After releasing the bus, if there is a transfer request for another channel, the DMAC requests the bus again.

Figure 7.19 shows the timing when channel 0A is set up for I/O mode and channel 1 for burst mode, and a transfer request for channel 0A is received while channel 1 is active.

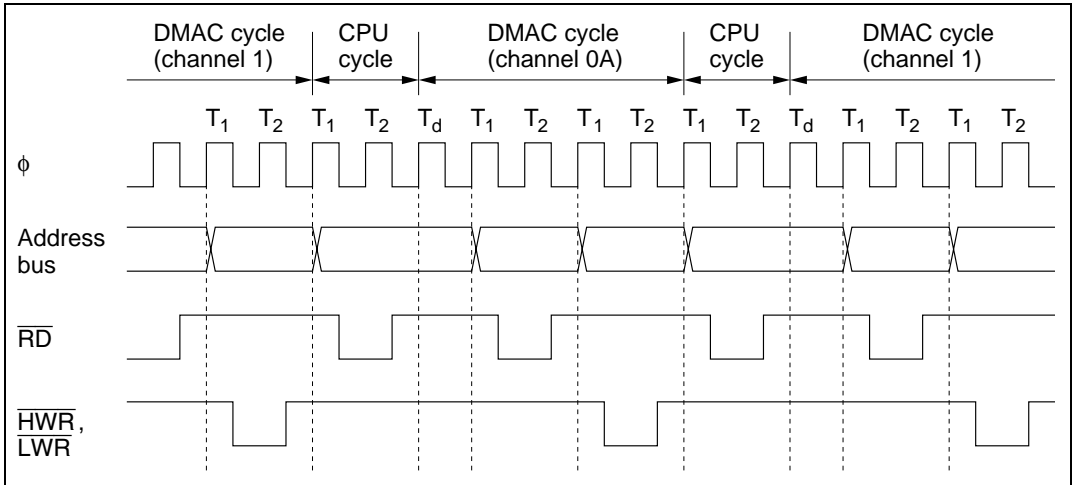

Figure 7.19 Timing of Multiple-Channel Operations

7.4.10 External Bus Requests, DRAM Interface, and DMAC

During a DMAC transfer, if the bus right is requested by an external bus request signal (\overline{BREQ}) or by the DRAM interface (refresh cycle), the DMAC releases the bus after completing the transfer of the current byte or word. If there is a transfer request at this point, the DMAC requests the bus right again. Figure 7.20 shows an example of the timing of insertion of a refresh cycle during a burst transfer on channel 0.

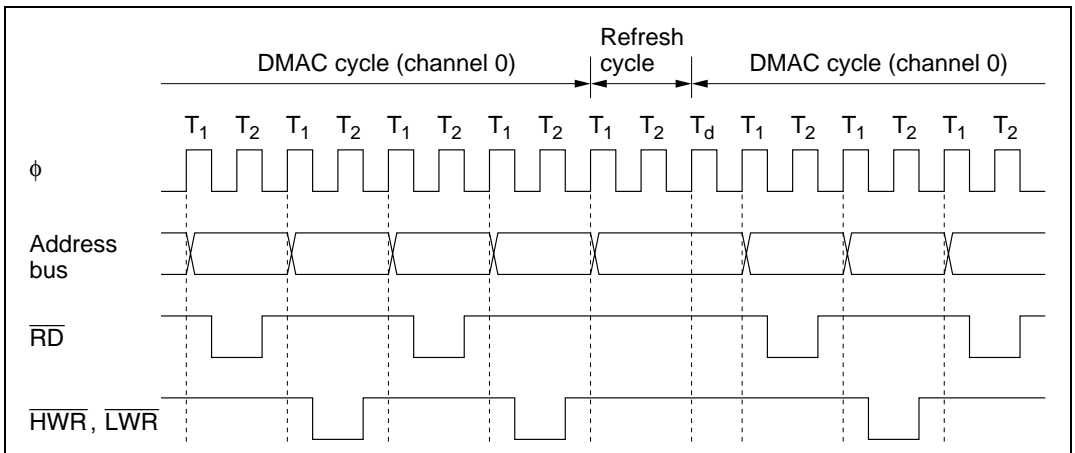

Figure 7.20 Bus Timing of DRAM Interface, and DMAC

7.4.11 NMI Interrupts and DMAC

NMI interrupts do not affect DMAC operations in short address mode.

If an NMI interrupt occurs during a transfer in full address mode, the DMAC suspends operations. In full address mode, a channel is enabled when its DTE and DTME bits are both set to 1. NMI input clears the DTME bit to 0. After transferring the current byte or word, the DMAC releases the bus to the CPU. In normal mode, the suspended transfer resumes when the CPU sets the DTME bit to 1 again. Check that the DTE bit is set to 1 and the DTME bit is cleared to 0 before setting the DTME bit to 1.

Figure 7.21 shows the procedure for resuming a DMAC transfer in normal mode on channel 0 after the transfer was halted by NMI input.

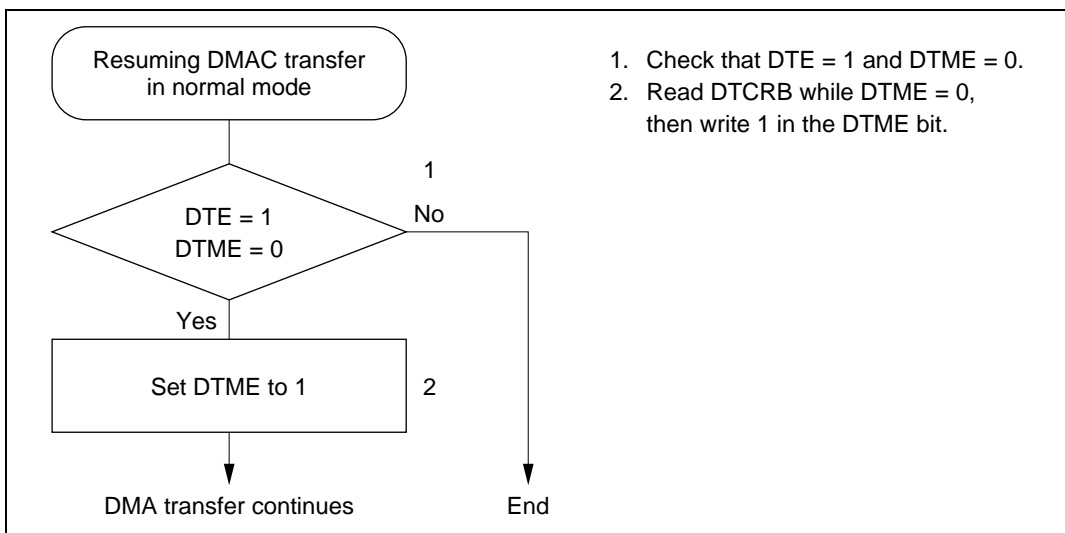

Figure 7.21 Procedure for Resuming a DMAC Transfer Halted by NMI (Example)

For information about NMI interrupts in block transfer mode, see section 7.6.6, NMI Interrupts and Block Transfer Mode.

7.4.12 Aborting a DMAC Transfer

When the DTE bit in an active channel is cleared to 0, the DMAC halts after transferring the current byte or word. The DMAC starts again when the DTE bit is set to 1. In full address mode, the DTME bit can be used for the same purpose. Figure 7.22 shows the procedure for aborting a DMAC transfer by software.

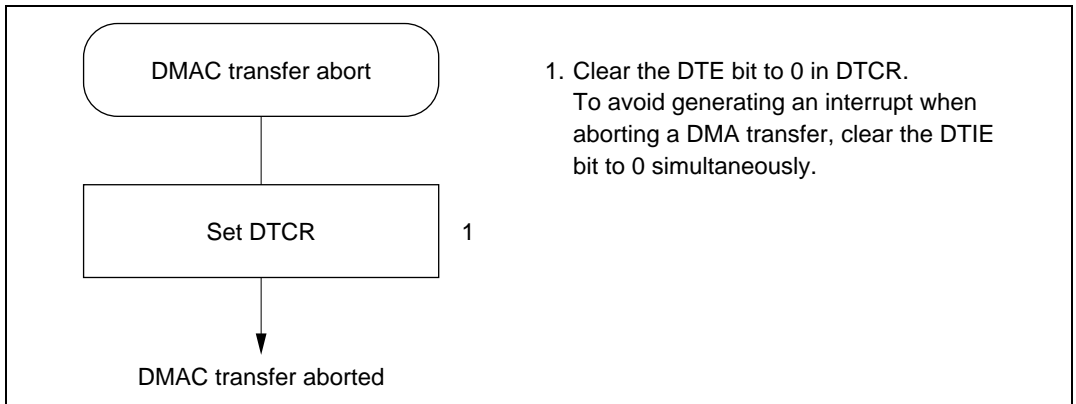

Figure 7.22 Procedure for Aborting a DMAC Transfer

7.4.13 Exiting Full Address Mode

Figure 7.23 shows the procedure for exiting full address mode and initializing the pair of channels. To set the channels up in another mode after exiting full address mode, follow the setup procedure for the relevant mode.

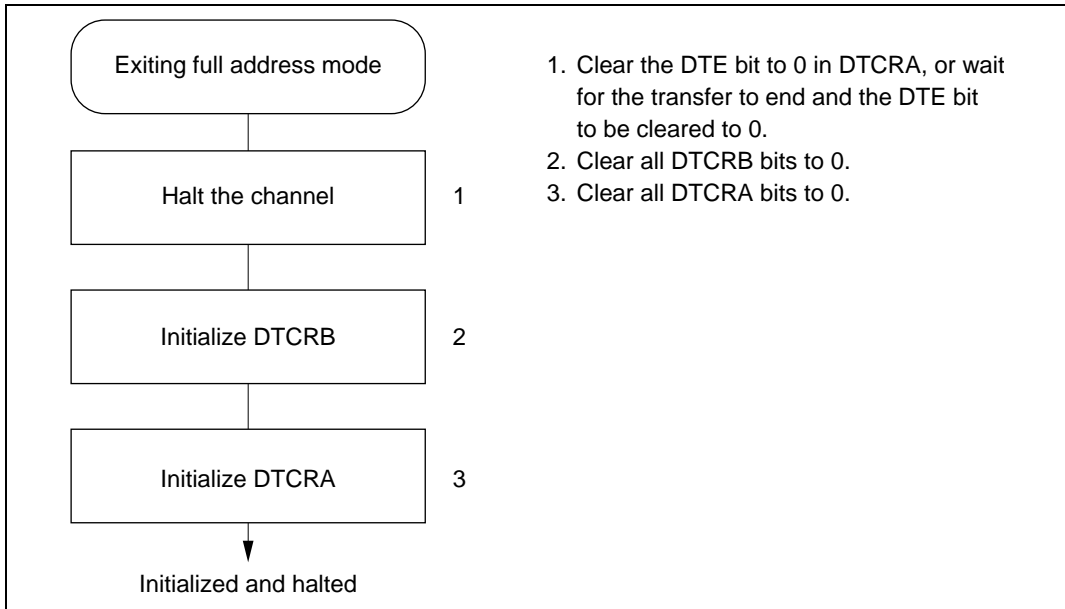

Figure 7.23 Procedure for Exiting Full Address Mode (Example)

7.4.14 DMAC States in Reset State, Standby Modes, and Sleep Mode

When the chip is reset or enters software standby mode, the DMAC is initialized and halts. DMAC operations continue in sleep mode. Figure 7.24 shows the timing of a cycle-steal transfer in sleep mode.

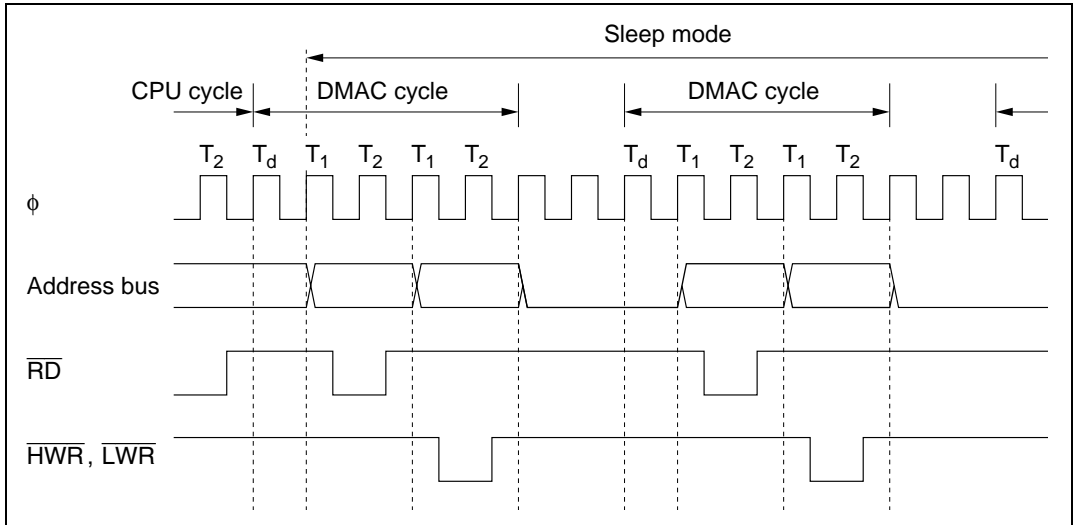

Figure 7.24 Timing of Cycle-Steal Transfer in Sleep Mode

7.5 Interrupts

The DMAC generates only DMA-end interrupts. Table 7.13 lists the interrupts and their priority.

Table 7.13 DMAC Interrupts

Interrupt	Description		Interrupt Priority
	Short Address Mode	Full Address Mode	
DEND0A	End of transfer on channel 0A	End of transfer on channel 0	High
DEND0B	End of transfer on channel 0B	—	↑
DEND1A	End of transfer on channel 1A	End of transfer on channel 1	↓
DEND1B	End of transfer on channel 1B	—	Low

Each interrupt is enabled or disabled by the DTIE bit in the corresponding data transfer control register (DTCR). Separate interrupt signals are sent to the interrupt controller.

The interrupt priority order among channels is channel 0 > channel 1 and channel A > channel B.

Figure 7.25 shows the DMA-end interrupt logic. An interrupt is requested whenever DTE = 0 and DTIE = 1.

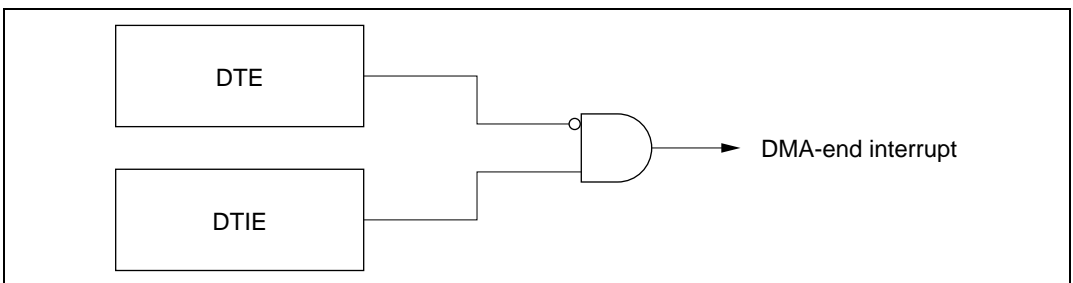

Figure 7.25 DMA-End Interrupt Logic

The DMA-end interrupt for the B channels (DENDB) is unavailable in full address mode. The DTME bit does not affect interrupt operations.

7.6 Usage Notes

7.6.1 Note on Word Data Transfer

Word data cannot be accessed starting at an odd address. When word-size transfer is selected, set even values in the memory and I/O address registers (MAR and IOAR).

7.6.2 DMAC Self-Access

The DMAC itself cannot be accessed during a DMAC cycle. DMAC registers cannot be specified as source or destination addresses.

7.6.3 Longword Access to Memory Address Registers

A memory address register can be accessed as longword data at the MARR address.

Example

```
MOV.L #LBL, ERO
MOV.L ERO, @MARR
```

Four byte accesses are performed. Note that the CPU may release the bus between the second byte (MARE) and third byte (MARH).

Memory address registers should be written and read only when the DMAC is halted.

7.6.4 Note on Full Address Mode Setup

Full address mode is controlled by two registers: DTCRA and DTCRB. Care must be taken to prevent the B channel from operating in short address mode during the register setup. The enable bits (DTE and DTME) should not be set to 1 until the end of the setup procedure.

7.6.5 Note on Activating DMAC by Internal Interrupts

When using an internal interrupt to activate the DMAC, make sure that the interrupt selected as the activating source does not occur during the interval after it has been selected but before the DMAC has been enabled. The on-chip supporting module that will generate the interrupt should not be activated until the DMAC has been enabled. If the DMAC must be enabled while the on-chip supporting module is active, follow the procedure in figure 7.26.

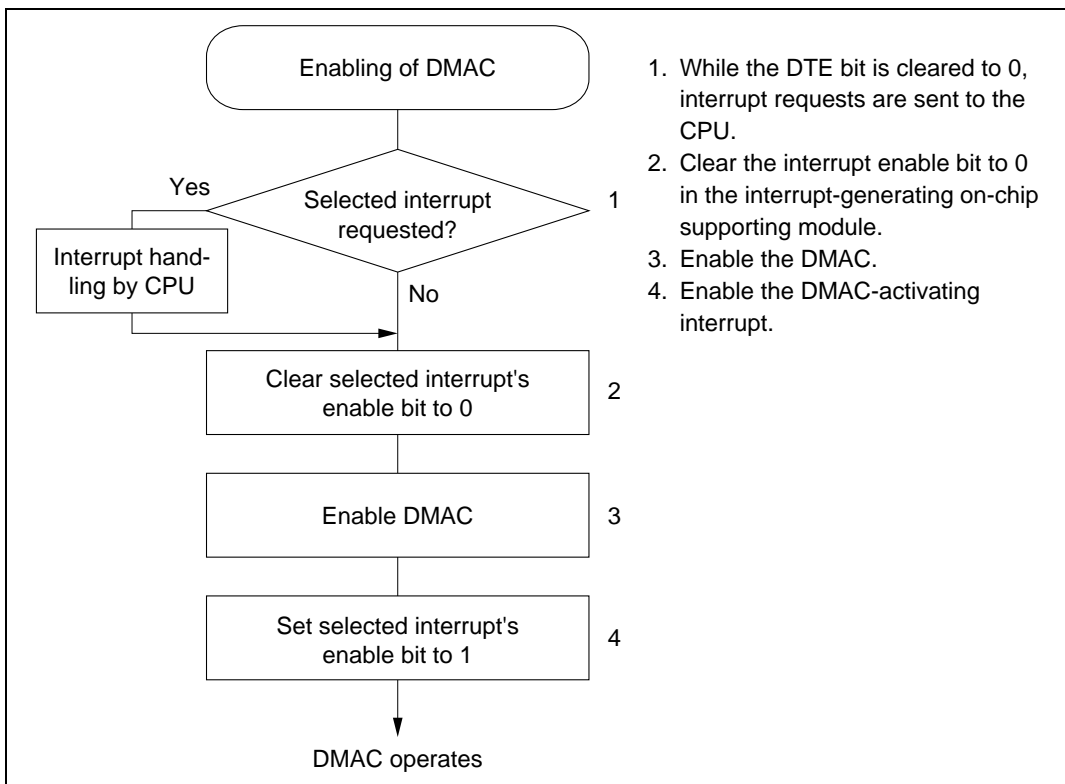

Figure 7.26 Procedure for Enabling DMAC while On-Chip Supporting Module is Operating (Example)

If the DTE bit is set to 1 but the DTME bit is cleared to 0, the DMAC is halted and the selected activating source cannot generate a CPU interrupt. If the DMAC is halted by an NMI interrupt, for example, the selected activating source cannot generate CPU interrupts. To terminate DMAC operations in this state, clear the DTE bit to 0 to allow CPU interrupts to be requested. To continue DMAC operations, carry out steps 2 and 4 in figure 7.26 before and after setting the DTME bit to 1.

When 16-bit timer interrupt activates the DMAC, make sure the next interrupt does not occur before the DMA transfer ends. If one 16-bit timer interrupt activates two or more channels, make sure the next interrupt does not occur before the DMA transfers end on all the activated channels. If the next interrupt occurs before a transfer ends, the channel or channels for which that interrupt was selected may fail to accept further activation requests.

7.6.6 NMI Interrupts and Block Transfer Mode

If an NMI interrupt occurs in block transfer mode, the DMAC operates as follows.

- When the NMI interrupt occurs, the DMAC finishes transferring the current byte or word, then clears the DTME bit to 0 and halts. The halt may occur in the middle of a block. It is possible to find whether a transfer was halted in the middle of a block by checking the block size counter. If the block size counter does not have its initial value, the transfer was halted in the middle of a block.
- If the transfer is halted in the middle of a block, the activating interrupt flag is cleared to 0. The activation request is not held pending.
- While the DTE bit is set to 1 and the DTME bit is cleared to 0, the DMAC is halted and does not accept activating interrupt requests. If an activating interrupt occurs in this state, the DMAC does not operate and does not hold the transfer request pending internally. Neither is a CPU interrupt requested.

For this reason, before setting the DTME bit to 1, first clear the enable bit of the activating interrupt to 0. Then, after setting the DTME bit to 1, set the interrupt enable bit to 1 again. See section 7.6.5, Note on Activating DMAC by Internal Interrupts.

- When the DTME bit is set to 1, the DMAC waits for the next transfer request. If it was halted in the middle of a block transfer, the rest of the block is transferred when the next transfer request occurs. Otherwise, the next block is transferred when the next transfer request occurs.

7.6.7 Memory and I/O Address Register Values

Table 7.14 indicates the address ranges that can be specified in the memory and I/O address registers (MAR and IOAR).

Table 7.14 Address Ranges Specifiable in MAR and IOAR

	1-Mbyte Mode	16-Mbyte Mode
MAR	H'00000 to H'FFFFF (0 to 1048575)	H'000000 to H'FFFFFF (0 to 16777215)
IOAR	H'FFF00 to H'FFFFF (1048320 to 1048575)	H'FFFF00 to H'FFFFFF (16776960 to 16777215)

MAR bits 23 to 20 are ignored in 1-Mbyte mode.

7.6.8 Bus Cycle when Transfer is Aborted

When a transfer is aborted by clearing the DTE bit or suspended by an NMI that clears the DTME bit, if this halts a channel for which the DMAC has a transfer request pending internally, a dead cycle may occur. This dead cycle does not update the halted channel's address register or counter value. Figure 7.27 shows an example in which an auto-requested transfer in cycle-steal mode on channel 0 is aborted by clearing the DTE bit in channel 0.

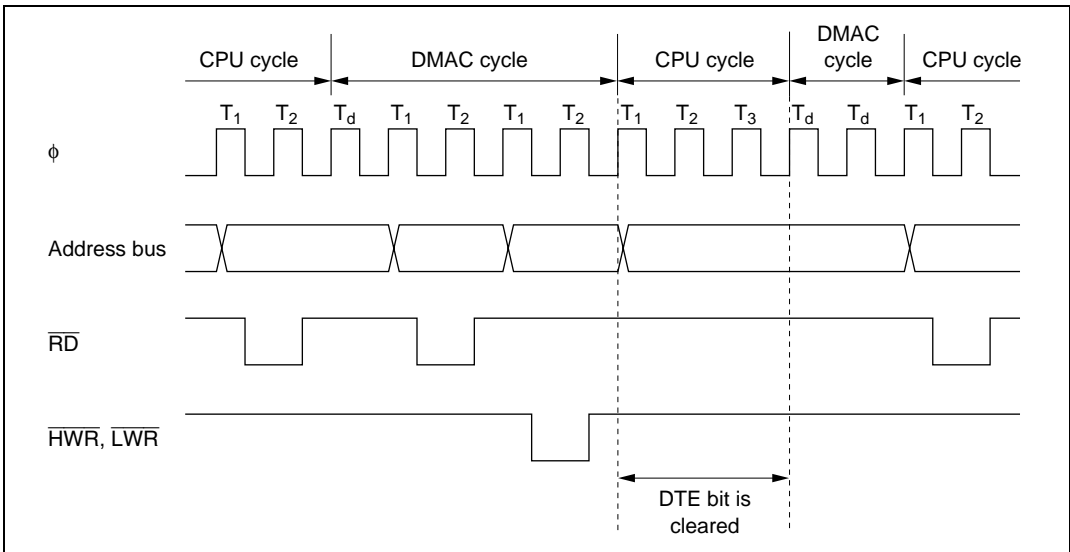

Figure 7.27 Bus Timing at Abort of DMA Transfer in Cycle-Steal Mode

7.6.9 Transfer Requests by A/D Converter

When the A/D converter is set to scan mode and conversion is performed on more than one channel, the A/D converter generates a transfer request when all conversions are completed. The converted data is stored in the appropriate ADDR registers. Block transfer mode and full address mode should therefore be used to transfer all the conversion results at one time.

Section 8 I/O Ports

8.1 Overview

The H8/3068F has 11 input/output ports (ports 1, 2, 3, 4, 5, 6, 7, 8, 9, A, and B). Table 8.1 summarizes the port functions. The pins in each port are multiplexed as shown in table 8.1.

Each port has a data direction register (DDR) for selecting input or output, and a data register (DR) for storing output data. In addition to these registers, ports 2, 4, and 5 have an input pull-up control register (PCR) for switching input pull-up transistors on and off.

Ports 1 to 6 and port 8 can drive one TTL load and a 90-pF capacitive load. Ports 9, A, and B can drive one TTL load and a 30-pF capacitive load. Ports 1 to 6 and 8 to B can drive a darlington pair. Ports 1, 2, and 5 can drive LEDs (with 10-mA current sink). Pins P8₂ to P8₀, PA₇ to PA₀ have Schmitt-trigger input circuits.

For block diagrams of the ports see appendix C, I/O Port Block Diagrams.

Table 8.1 Port Functions

Port	Description	Pins	Expanded Modes					Single-Chip Modes	
			Mode 1	Mode 2	Mode 3	Mode 4	Mode 5	Mode 6	Mode 7
Port 1	<ul style="list-style-type: none"> 8-bit I/O port Can drive LEDs 	P1 ₇ to P1 ₀ / A ₇ to A ₀	Address output pins (A ₇ to A ₀)				Address output (A ₇ to A ₀) and generic input DDR = 0: generic input DDR = 1: address output	Generic input/output	
Port 2	<ul style="list-style-type: none"> 8-bit I/O port Built-in input pull-up transistors Can drive LEDs 	P2 ₇ to P2 ₀ / A ₁₅ to A ₈	Address output pins (A ₁₅ to A ₈)				Address output (A ₁₅ to A ₈) and generic input DDR = 0: generic input DDR = 1: address output	Generic input/output	
Port 3	<ul style="list-style-type: none"> 8-bit I/O port 	P3 ₇ to P3 ₀ / D ₁₅ to D ₈	Data input/output (D ₁₅ to D ₈)					Generic input/output	
Port 4	<ul style="list-style-type: none"> 8-bit I/O port Built-in input pull-up transistors 	P4 ₇ to P4 ₀ / D ₇ to D ₀	Data input/output (D ₇ to D ₀) and 8-bit generic input/output 8-bit bus mode: generic input/output 16-bit bus mode: data input/output					Generic input/output	
Port 5	<ul style="list-style-type: none"> 4-bit I/O port Built-in input pull-up transistors Can drive LEDs 	P5 ₃ to P5 ₀ / A ₁₉ to A ₁₆	Address output (A ₁₉ to A ₁₆)			Address output (A ₁₉ to A ₁₆) and 4-bit generic input DDR = 0: generic input DDR = 1: address output		Generic input/output	
Port 6	<ul style="list-style-type: none"> 8-bit I/O port 	P6 ₇ /φ	Clock output (φ) and generic input						
		P6 ₆ /LWR P6 ₆ /HWR P6 ₆ /RD P6 ₆ /AS	Bus control signal output (LWR, HWR, RD, AS)					Generic input/output	
		P6 ₂ /BACK P6 ₁ /BREQ P6 ₀ /WAIT	Bus control signal input/output (BACK, BREQ, WAIT) and 3-bit generic input/output						
Port 7	<ul style="list-style-type: none"> 8-bit I/O port 	P7 ₇ /AN ₇ /DA ₁ P7 ₆ /AN ₆ /DA ₀	Analog input (AN ₇ , AN ₆) to A/D converter, analog output (DA ₁ , DA ₀) from D/A converter, and generic input						
		P7 ₅ to P7 ₀ / AN ₅ to AN ₀	Analog input (AN ₅ to AN ₀) to A/D converter, and generic input						

Port	Description	Pins	Expanded Modes					Single-Chip Modes				
			Mode 1	Mode 2	Mode 3	Mode 4	Mode 5	Mode 6	Mode 7			
Port 8	<ul style="list-style-type: none"> 5-bit I/O port P8₂ to P8₀ have Schmitt inputs 	P8 ₄ / \overline{CS}_0	DDR = 0: generic input DDR = 1 (reset value): \overline{CS}_0 output			DDR = 0 (reset value): generic input DDR = 1: \overline{CS}_0 output		Generic input/output				
		P8 ₃ / \overline{IRQ}_3 / \overline{CS}_1 /ADTRG	\overline{IRQ}_3 input, \overline{CS}_1 output, external trigger input (ADTRG) to A/D converter, and generic input DDR = 0 (after reset): generic input DDR = 1: \overline{CS}_1 output				\overline{IRQ}_3 input, external trigger input (ADTRG) to A/D converter, and generic input/output					
		P8 ₂ / \overline{IRQ}_2 / \overline{CS}_2 / P8 ₁ / \overline{IRQ}_1 / \overline{CS}_3	\overline{IRQ}_2 and \overline{IRQ}_1 input, \overline{CS}_2 and \overline{CS}_3 output, and generic input* DDR = 0 (reset value): generic input DDR = 1: \overline{CS}_2 and \overline{CS}_3 output				\overline{IRQ}_2 and \overline{IRQ}_1 input and generic input/output					
		P8 ₀ / \overline{IRQ}_0 /RFSH	\overline{IRQ}_0 input, RFSH output, and generic input/output				\overline{IRQ}_0 input and generic input/output					
Port 9	6-bit I/O port	P9 ₂ / \overline{IRQ}_5 /SCK ₁ P9 ₄ / \overline{IRQ}_4 /SCK ₀ P9 ₃ /Rx _{D1} P9 ₂ /Rx _{D0} P9 ₁ /Tx _{D1} P9 ₀ /Tx _{D0}	Input and output (SCK ₁ , SCK ₀ , Rx _{D1} , Rx _{D0} , Tx _{D1} , Tx _{D0}) for serial communication interfaces 1 and 0 (SCH1/0), \overline{IRQ}_5 and \overline{IRQ}_4 input, and 6-bit generic input/output									
Port A	<ul style="list-style-type: none"> 8-bit I/O port Schmitt inputs 	PA ₇ /TP ₇ / TIOCB ₂ /A ₂₀	Output (TP ₇) from programmable timing pattern controller (TPC), input or output (TIOCB ₂) for 16-bit timer and generic input/output		Address output (A ₂₀)		Address output (A ₂₀), TPC output (TP ₇), input or output (TIOCB ₂) for 16-bit timer, and generic input/output		TPC output (TP ₇), 16-bit timer input or output (TIOCB ₂), and generic input/output			
		PA ₆ /TP ₆ / TIOCA ₂ /A ₂₁ PA ₅ /TP ₅ / TIOCB ₁ /A ₂₂ PA ₄ /TP ₄ / TIOCA ₁ /A ₂₃	TPC output (TP ₆ to TP ₄), 16-bit timer input and output (TIOCA ₂ , TIOCB ₁ , TIOCA ₁), and generic input/output		TPC output (TP ₆ to TP ₄), 16-bit timer input and output (TIOCA ₂ , TIOCB ₁ , TIOCA ₁), address output (A ₂₃ to A ₂₁), and generic input/output		TPC output (TP ₆ to TP ₄), 16-bit timer input and output (TIOCA ₂ , TIOCB ₁ , TIOCA ₁) and generic input/output					
		PA ₃ /TP ₃ / TIOCB ₀ / TCLKD PA ₂ /TP ₂ / TIOCA ₀ / TCLKC PA ₁ /TP ₁ / TCLKB /TEND ₁ PA ₀ /TP ₀ / TCLKA /TEND ₀	TPC output (TP ₃ to TP ₀), 16-bit timer input and output (TIOCB ₀ , TIOCA ₀ , TCLKD, TCLKC, TCLKB, TCLKA), 8-bit timer input (TCLKD, TCLKC, TCLKB, TCLKA), output (TEND ₁ , TEND ₀) from DMA controller (DMAC), and generic input/output									
Port B	8-bit I/O port	PB ₇ /TP ₁₅ / RXD ₂ PB ₆ /TP ₁₄ / TXD ₂ PB ₅ /TP ₁₃ / SCK ₂ /LCAS PB ₄ /TP ₁₂ / UCAS	TPC output (TP ₁₅ to TP ₁₂), SCI2 input and output (SCK ₂ , Rx _{D2} , Tx _{D2}), DRAM interface output (LCAS, UCAS), and generic input/output					TPC output (TP ₁₅ to TP ₁₂), SCI2 input and output (SCK ₂ , Rx _{D2} , Tx _{D2}), and generic input/output				
		PB ₃ /TP ₁₁ / TMIO ₃ / \overline{DREQ}_1 / \overline{CS}_4 PB ₂ /TP ₁₀ / TMO ₂ / \overline{CS}_5 PB ₁ /TP ₉ / TMIO ₁ / \overline{DREQ}_0 / \overline{CS}_6 PB ₀ /TP ₈ / TMO ₀ / \overline{CS}_7	TPC output (TP ₁₁ to TP ₈), 8-bit timer input and output (TMIO ₃ , TMO ₂ , TMIO ₁ , TMO ₀), DMAC input (\overline{DREQ}_1 , \overline{DREQ}_0), \overline{CS}_7 to \overline{CS}_5 output, and generic input/output					TPC output (TP ₁₁ to TP ₈), 8-bit timer input and output (TMIO ₃ , TMO ₂ , TMIO ₁ , TMO ₀), DMAC input (\overline{DREQ}_1 , \overline{DREQ}_0), and generic input/output				

Note: * P8₁ can be used as an output port by making a setting in DRCRA.

8.2 Port 1

8.2.1 Overview

Port 1 is an 8-bit input/output port also used for address output, with the pin configuration shown in figure 8.1. The pin functions differ between the expanded modes with on-chip ROM disabled, expanded modes with on-chip ROM enabled, and single-chip mode. In modes 1 to 4 (expanded modes with on-chip ROM disabled), they are address bus output pins (A_7 to A_0).

In modes 5 (expanded modes with on-chip ROM enabled), settings in the port 1 data direction register (P1DDR) can designate pins for address bus output (A_7 to A_0) or generic input. In mode 6 and 7 (single-chip mode), port 1 is a generic input/output port.

When DRAM is connected to area 2, 3, 4, 5, A_7 to A_0 output row and column addresses in read and write cycles. For details see section 6.5, DRAM Interface.

Pins in port 1 can drive one TTL load and a 90-pF capacitive load. They can also drive an LED or a darlington transistor pair.

	Port 1 pins	Modes 1 to 4	Modes 5	Mode 6 and 7
	$P1_7/A_7$	A_7 (output)	$P1_7$ (input)/ A_7 (output)	$P1_7$ (input/output)
	$P1_6/A_6$	A_6 (output)	$P1_6$ (input)/ A_6 (output)	$P1_6$ (input/output)
	$P1_5/A_5$	A_5 (output)	$P1_5$ (input)/ A_5 (output)	$P1_5$ (input/output)
	$P1_4/A_4$	A_4 (output)	$P1_4$ (input)/ A_4 (output)	$P1_4$ (input/output)
	$P1_3/A_3$	A_3 (output)	$P1_3$ (input)/ A_3 (output)	$P1_3$ (input/output)
	$P1_2/A_2$	A_2 (output)	$P1_2$ (input)/ A_2 (output)	$P1_2$ (input/output)
	$P1_1/A_1$	A_1 (output)	$P1_1$ (input)/ A_1 (output)	$P1_1$ (input/output)
	$P1_0/A_0$	A_0 (output)	$P1_0$ (input)/ A_0 (output)	$P1_0$ (input/output)

Figure 8.1 Port 1 Pin Configuration

8.2.2 Register Descriptions

Table 8.2 summarizes the registers of port 1.

Table 8.2 Port 1 Registers

Address*	Name	Abbreviation	R/W	Initial Value	
				Modes 1 to 4	Modes 5 to 7
H'EE000	Port 1 data direction register	P1DDR	W	H'FF	H'00
H'FFFD0	Port 1 data register	P1DR	R/W	H'00	H'00

Note: * Lower 20 bits of the address in advanced mode.

Port 1 Data Direction Register (P1DDR): P1DDR is an 8-bit write-only register that can select input or output for each pin in port 1.

Bit		7	6	5	4	3	2	1	0
		P1 ₇ DDR	P1 ₆ DDR	P1 ₅ DDR	P1 ₄ DDR	P1 ₃ DDR	P1 ₂ DDR	P1 ₁ DDR	P1 ₀ DDR
Modes 1 to 4	Initial value	1	1	1	1	1	1	1	1
	Read/Write	—	—	—	—	—	—	—	—
Modes 5 to 7	Initial value	0	0	0	0	0	0	0	0
	Read/Write	W	W	W	W	W	W	W	W

Port 1 data direction 7 to 0

These bits select input or output for port 1 pins

Modes 1 to 4 (Expanded Modes with On-Chip ROM Disabled): P1DDR values are fixed at 1. Port 1 functions as an address bus.

Modes 5 (Expanded Modes with On-Chip ROM Enabled): After a reset, port 1 functions as an input port. A pin in port 1 becomes an address output pin if the corresponding P1DDR bit is set to 1, and a generic input pin if this bit is cleared to 0.

Mode 6 and 7 (Single-Chip Mode): Port 1 functions as an input/output port. A pin in port 1 becomes an output port if the corresponding P1DDR bit is set to 1, and an input port if this bit is cleared to 0.

In modes 1 to 4, P1DDR bits are always read as 1, and cannot be modified.

In modes 5 to 7, P1DDR is a write-only register. Its value cannot be read. All bits return 1 when read.

P1DDR is initialized to H'FF in modes 1 to 4, and to H'00 in modes 5 to 7, by a reset and in hardware standby mode. In software standby mode it retains its previous setting. Therefore, if a transition is made to software standby mode while port 1 is functioning as an input/output port and a P1DDR bit is set to 1, the corresponding pin maintains its output state.

Port 1 Data Register (P1DR): P1DR is an 8-bit readable/writable register that stores port 1 output data. When port 1 functions as an output port, the value of this register is output. When this register is read, the pin logic level is read for bits for which the P1DDR setting is 0, and the P1DR value is read for bits for which the P1DDR setting is 1.

Bit	7	6	5	4	3	2	1	0
	P1 ₇	P1 ₆	P1 ₅	P1 ₄	P1 ₃	P1 ₂	P1 ₁	P1 ₀
Initial value	0	0	0	0	0	0	0	0
Read/Write	R/W	R/W	R/W	R/W	R/W	R/W	R/W	R/W

Port 1 data 7 to 0

These bits store data for port 1 pins

P1DR is initialized to H'00 by a reset and in hardware standby mode. In software standby mode it retains its previous setting.

8.3 Port 2

8.3.1 Overview

Port 2 is an 8-bit input/output port with the pin configuration shown in figure 8.2. The pin functions differ according to the operating mode.

In modes 1 to 4 (expanded modes with on-chip ROM disabled), port 2 consists of address bus output pins (A_{15} to A_8). In modes 5 (expanded modes with on-chip ROM enabled), settings in the port 2 data direction register (P2DDR) can designate pins for address bus output (A_{15} to A_8) or generic input. In mode 6 and 7 (single-chip mode), port 2 is a generic input/output port.

When DRAM is connected to areas 2 to 5, A_{12} to A_8 output row and column addresses in read and write cycles. For details see section 6.5, DRAM Interface.

Port 2 has software-programmable built-in pull-up transistors.

Pins in port 2 can drive one TTL load and a 90-pF capacitive load. They can also drive an LED or a darlington transistor pair.

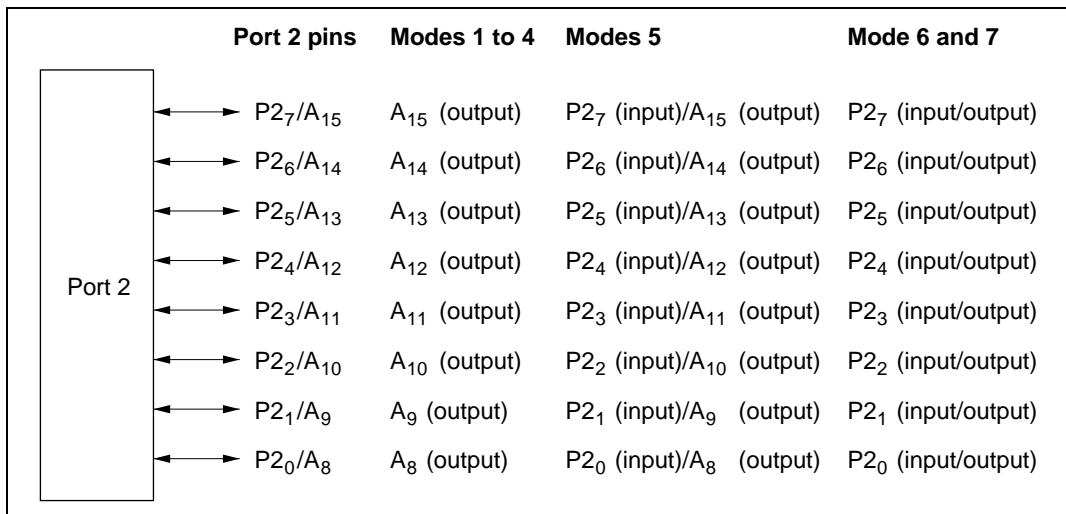

Figure 8.2 Port 2 Pin Configuration

8.3.2 Register Descriptions

Table 8.3 summarizes the registers of port 2.

Table 8.3 Port 2 Registers

Address*	Name	Abbreviation	R/W	Initial Value	
				Modes 1 to 4	Modes 5 to 7
H'EE001	Port 2 data direction register	P2DDR	W	H'FF	H'00
H'FFFD1	Port 2 data register	P2DR	R/W	H'00	H'00
H'EE03C	Port 2 input pull-up MOS control register	P2PCR	R/W	H'00	H'00

Note: * Lower 20 bits of the address in advanced mode.

Port 2 Data Direction Register (P2DDR): P2DDR is an 8-bit write-only register that can select input or output for each pin in port 2.

Bit								
	7	6	5	4	3	2	1	0
	P2 ₇ DDR	P2 ₆ DDR	P2 ₅ DDR	P2 ₄ DDR	P2 ₃ DDR	P2 ₂ DDR	P2 ₁ DDR	P2 ₀ DDR
Modes 1 to 4	Initial value	1	1	1	1	1	1	1
	Read/Write	—	—	—	—	—	—	—
Modes 5 to 7	Initial value	0	0	0	0	0	0	0
	Read/Write	W	W	W	W	W	W	W

Port 2 data direction 7 to 0

These bits select input or output for port 2 pins

Modes 1 to 4 (Expanded Modes with On-Chip ROM Disabled): P2DDR values are fixed at 1. Port 2 functions as an address bus.

Modes 5 (Expanded Modes with On-Chip ROM Enabled): Following a reset, port 2 is an input port. A pin in port 2 becomes an address output pin if the corresponding P2DDR bit is set to 1, and a generic input port if this bit is cleared to 0.

Mode 6 and 7 (Single-Chip Mode): Port 2 functions as an input/output port. A pin in port 2 becomes an output port if the corresponding P2DDR bit is set to 1, and an input port if this bit is cleared to 0.

In modes 1 to 4, P2DDR bits are always read as 1, and cannot be modified.

In modes 5 to 7, P2DDR is a write-only register. Its value cannot be read. All bits return 1 when read.

P2DDR is initialized to H'FF in modes 1 to 4, and to H'00 in modes 5 to 7, by a reset and in hardware standby mode. In software standby mode it retains its previous setting. Therefore, if a transition is made to software standby mode while port 2 is functioning as an input/output port and a P2DDR bit is set to 1, the corresponding pin maintains its output state.

Port 2 Data Register (P2DR): P2DR is an 8-bit readable/writable register that stores output data for Port 2. When port 2 functions as an output port, the value of this register is output. When a bit in P2DDR is set to 1, if port 2 is read the value of the corresponding P2DR bit is returned. When a bit in P2DDR is cleared to 0, if port 2 is read the corresponding pin logic level is read.

Bit	7	6	5	4	3	2	1	0
	P2 ₇	P2 ₆	P2 ₅	P2 ₄	P2 ₃	P2 ₂	P2 ₁	P2 ₀
Initial value	0	0	0	0	0	0	0	0
Read/Write	R/W	R/W	R/W	R/W	R/W	R/W	R/W	R/W

Port 2 data 7 to 0

These bits store data for port 2 pins

P2DR is initialized to H'00 by a reset and in hardware standby mode. In software standby mode it retains its previous setting.

Port 2 Input Pull-Up MOS Control Register (P2PCR): P2PCR is an 8-bit readable/writable register that controls the MOS input pull-up transistors in port 2.

Bit	7	6	5	4	3	2	1	0
	P2 ₇ PCR	P2 ₆ PCR	P2 ₅ PCR	P2 ₄ PCR	P2 ₃ PCR	P2 ₂ PCR	P2 ₁ PCR	P2 ₀ PCR
Initial value	0	0	0	0	0	0	0	0
Read/Write	R/W	R/W	R/W	R/W	R/W	R/W	R/W	R/W

Port 2 input pull-up MOS control 7 to 0

These bits control input pull-up transistors built into port 2

In modes 5 to 7, when a P2DDR bit is cleared to 0 (selecting generic input), if the corresponding bit in P2PCR is set to 1, the input pull-up transistor is turned on.

P2PCR is initialized to H'00 by a reset and in hardware standby mode. In software standby mode it retains its previous setting.

Table 8.4 Input Pull-Up Transistor States (Port 2)

Mode	Reset	Hardware Standby Mode	Software Standby Mode	Other Modes
1	Off	Off	Off	Off
2				
3				
4				
5	Off	Off	On/off	On/off
6				
7				

Legend

Off: The input pull-up transistor is always off.

On/off: The input pull-up transistor is on if P2PCR = 1 and P2DDR = 0. Otherwise, it is off.

8.4 Port 3

8.4.1 Overview

Port 3 is an 8-bit input/output port with the pin configuration shown in figure 8.3. Port 3 is a data bus in modes 1 to 5 (expanded modes) and a generic input/output port in mode 6, 7 (single-chip mode).

Pins in port 3 can drive one TTL load and a 90-pF capacitive load. They can also drive a darlington transistor pair.

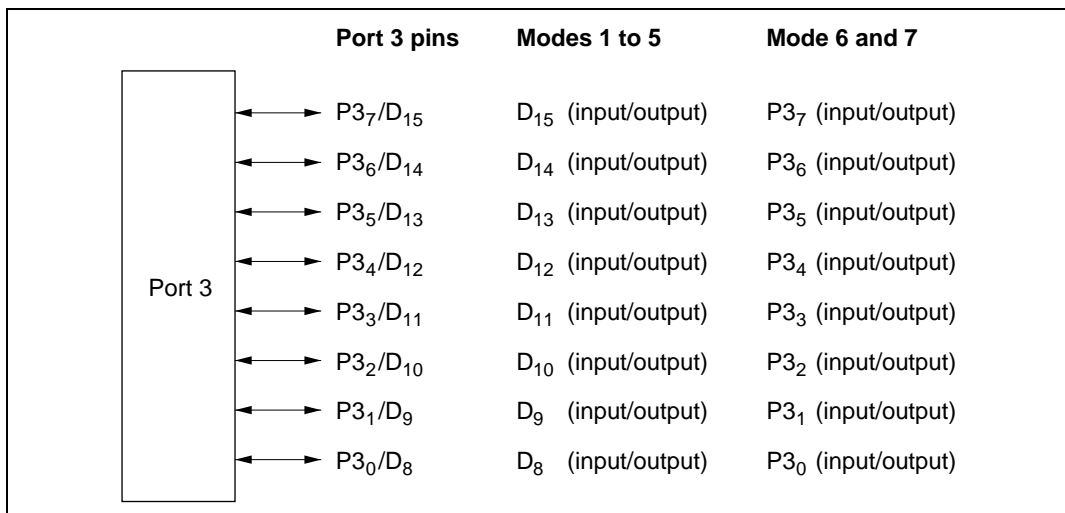

Figure 8.3 Port 3 Pin Configuration

8.4.2 Register Descriptions

Table 8.5 summarizes the registers of port 3.

Table 8.5 Port 3 Registers

Address*	Name	Abbreviation	R/W	Initial Value
H'EE002	Port 3 data direction register	P3DDR	W	H'00
H'FFFD2	Port 3 data register	P3DR	R/W	H'00

Note: * Lower 20 bits of the address in advanced mode.

Port 3 Data Direction Register (P3DDR): P3DDR is an 8-bit write-only register that can select input or output for each pin in port 3.

Bit	7	6	5	4	3	2	1	0
	P3 ₇ DDR	P3 ₆ DDR	P3 ₅ DDR	P3 ₄ DDR	P3 ₃ DDR	P3 ₂ DDR	P3 ₁ DDR	P3 ₀ DDR
Initial value	0	0	0	0	0	0	0	0
Read/Write	W	W	W	W	W	W	W	W

Port 3 data direction 7 to 0

These bits select input or output for port 3 pins

Modes 1 to 5 (Expanded Modes): Port 3 functions as a data bus, regardless of the P3DDR settings.

Mode 6 and 7 (Single-Chip Mode): Port 3 functions as an input/output port. A pin in port 3 becomes an output port if the corresponding P3DDR bit is set to 1, and an input port if this bit is cleared to 0.

P3DDR is a write-only register. Its value cannot be read. All bits return 1 when read.

P3DDR is initialized to H'00 by a reset and in hardware standby mode. In software standby mode it retains its previous setting. Therefore, if a transition is made to software standby mode while port 3 is functioning as an input/output port and a P3DDR bit is set to 1, the corresponding pin maintains its output state.

Port 3 Data Register (P3DR): P3DR is an 8-bit readable/writable register that stores output data for port 3. When port 3 functions as an output port, the value of this register is output. When a bit in P3DDR is set to 1, if port 3 is read the value of the corresponding P3DR bit is returned. When a bit in P3DDR is cleared to 0, if port 3 is read the corresponding pin logic level is read.

Bit	7	6	5	4	3	2	1	0
	P3 ₇	P3 ₆	P3 ₅	P3 ₄	P3 ₃	P3 ₂	P3 ₁	P3 ₀
Initial value	0	0	0	0	0	0	0	0
Read/Write	R/W	R/W	R/W	R/W	R/W	R/W	R/W	R/W

Port 3 data 7 to 0

These bits store data for port 3 pins

P3DR is initialized to H'00 by a reset and in hardware standby mode. In software standby mode it retains its previous setting.

8.5 Port 4

8.5.1 Overview

Port 4 is an 8-bit input/output port with the pin configuration shown in figure 8.4. The pin functions differ depending on the operating mode.

In modes 1 to 5 (expanded modes), when the bus width control register (ABWCR) designates areas 0 to 7 all as 8-bit-access areas, the chip operates in 8-bit bus mode and port 4 is a generic input/output port. When at least one of areas 0 to 7 is designated as a 16-bit-access area, the chip operates in 16-bit bus mode and port 4 becomes part of the data bus. In mode 6, 7 (single-chip mode), port 4 is a generic input/output port.

Port 4 has software-programmable built-in pull-up transistors.

Pins in port 4 can drive one TTL load and a 90-pF capacitive load. They can also drive a darlington transistor pair.

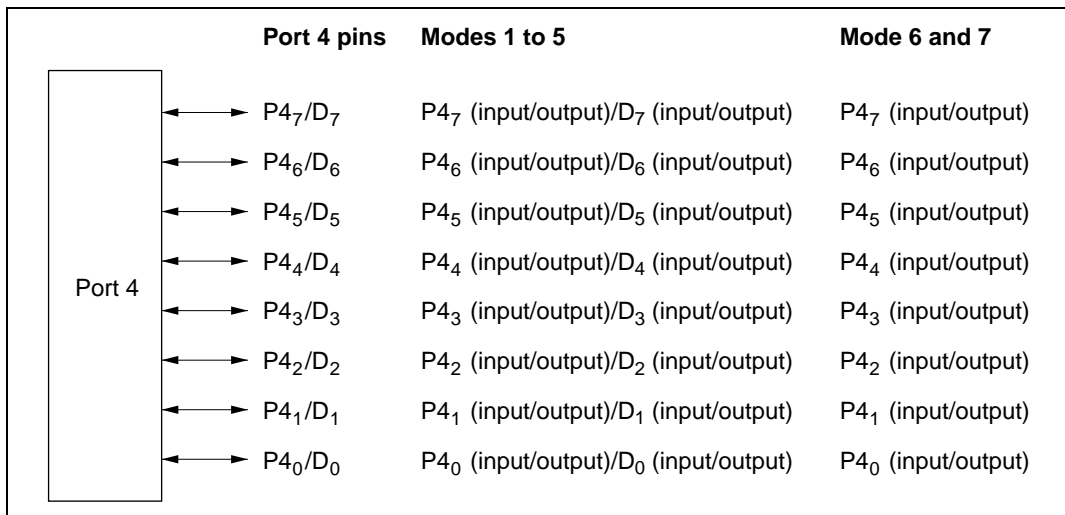

Figure 8.4 Port 4 Pin Configuration

8.5.2 Register Descriptions

Table 8.6 summarizes the registers of port 4.

Table 8.6 Port 4 Registers

Address*	Name	Abbreviation	R/W	Initial Value
H'EE003	Port 4 data direction register	P4DDR	W	H'00
H'FFFD3	Port 4 data register	P4DR	R/W	H'00
H'EE03E	Port 4 input pull-up control register	P4PCR	R/W	H'00

Note: * Lower 20 bits of the address in advanced mode.

Port 4 Data Direction Register (P4DDR): P4DDR is an 8-bit write-only register that can select input or output for each pin in port 4.

Bit	7	6	5	4	3	2	1	0
	P4 ₇ DDR	P4 ₆ DDR	P4 ₅ DDR	P4 ₄ DDR	P4 ₃ DDR	P4 ₂ DDR	P4 ₁ DDR	P4 ₀ DDR
Initial value	0	0	0	0	0	0	0	0
Read/Write	W	W	W	W	W	W	W	W

Port 4 data direction 7 to 0

These bits select input or output for port 4 pins

Modes 1 to 5 (Expanded Modes): When all areas are designated as 8-bit-access areas by the bus controller's bus width control register (ABWCR), selecting 8-bit bus mode, port 4 functions as an input/output port. In this case, a pin in port 4 becomes an output port if the corresponding P4DDR bit is set to 1, and an input port if this bit is cleared to 0.

When at least one area is designated as a 16-bit-access area, selecting 16-bit bus mode, port 4 functions as part of the data bus, regardless of the P4DDR settings.

Mode 6 and 7 (Single-Chip Mode): Port 4 functions as an input/output port. A pin in port 4 becomes an output port if the corresponding P4DDR bit is set to 1, and an input port if this bit is cleared to 0.

P4DDR is a write-only register. Its value cannot be read. All bits return 1 when read.

P4DDR is initialized to H'00 by a reset and in hardware standby mode. In software standby mode it retains its previous setting.

ABWCR and P4DDR are not initialized in software standby mode. Therefore, if a transition is made to software standby mode while port 4 is functioning as an input/output port and a P4DDR bit is set to 1, the corresponding pin maintains its output state.

Port 4 Data Register (P4DR): P4DR is an 8-bit readable/writable register that stores output data for port 4. When port 4 functions as an output port, the value of this register is output. When a bit in P4DDR is set to 1, if port 4 is read the value of the corresponding P4DR bit is returned. When a bit in P4DDR is cleared to 0, if port 4 is read the corresponding pin logic level is read.

Bit	7	6	5	4	3	2	1	0
	P4 ₇	P4 ₆	P4 ₅	P4 ₄	P4 ₃	P4 ₂	P4 ₁	P4 ₀
Initial value	0	0	0	0	0	0	0	0
Read/Write	R/W	R/W	R/W	R/W	R/W	R/W	R/W	R/W

Port 4 data 7 to 0

These bits store data for port 4 pins

P4DR is initialized to H'00 by a reset and in hardware standby mode. In software standby mode it retains its previous setting.

Port 4 Input Pull-Up MOS Control Register (P4PCR): P4PCR is an 8-bit readable/writable register that controls the MOS input pull-up transistors in port 4.

Bit	7	6	5	4	3	2	1	0
	P4 ₇ PCR	P4 ₆ PCR	P4 ₅ PCR	P4 ₄ PCR	P4 ₃ PCR	P4 ₂ PCR	P4 ₁ PCR	P4 ₀ PCR
Initial value	0	0	0	0	0	0	0	0
Read/Write	R/W	R/W	R/W	R/W	R/W	R/W	R/W	R/W

Port 4 input pull-up control 7 to 0

These bits control input pull-up transistors built into port 4

In mode 6 and 7 (single-chip mode), and in 8-bit bus mode in modes 1 to 5 (expanded modes), when a P4DDR bit is cleared to 0 (selecting generic input), if the corresponding P4PCR bit is set to 1, the input pull-up transistor is turned on.

P4PCR is initialized to H'00 by a reset and in hardware standby mode. In software standby mode it retains its previous setting.

Table 8.7 summarizes the states of the input pull-ups in each operating mode.

Table 8.7 Input Pull-Up Transistor States (Port 4)

Mode		Reset	Hardware Standby Mode	Software Standby Mode	Other Modes
1 to 5	8-bit bus mode	Off	Off	On/off	On/off
	16-bit bus mode			Off	Off
6 and 7				On/off	On/off

Legend

Off: The input pull-up transistor is always off.

On/off: The input pull-up transistor is on if P4PCR = 1 and P4DDR = 0. Otherwise, it is off.

8.6 Port 5

8.6.1 Overview

Port 5 is a 4-bit input/output port with the pin configuration shown in figure 8.5. The pin functions differ depending on the operating mode.

In modes 1 to 4 (expanded modes with on-chip ROM disabled), port 5 consists of address output pins (A_{19} to A_{16}). In modes 5 (expanded modes with on-chip ROM enabled), settings in the port 5 data direction register (P5DDR) designate pins for address bus output (A_{19} to A_{16}) or generic input. In mode 6, 7 (single-chip mode), port 5 is a generic input/output port.

Port 5 has software-programmable built-in pull-up transistors.

Pins in port 5 can drive one TTL load and a 90-pF capacitive load. They can also drive an LED or a darlington transistor pair.

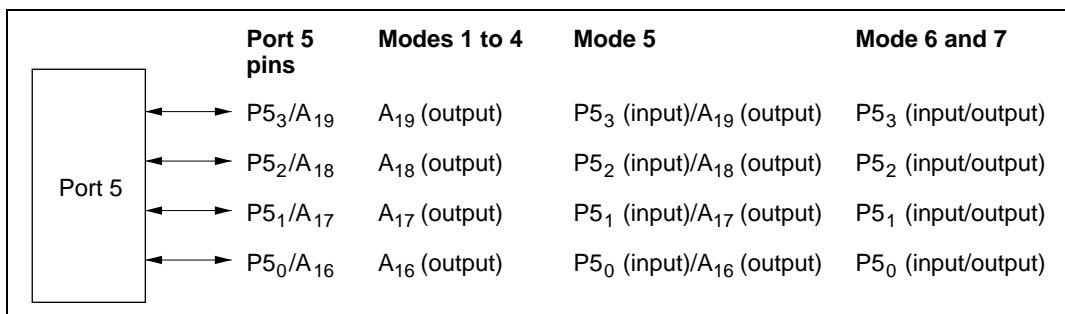

Figure 8.5 Port 5 Pin Configuration

8.6.2 Register Descriptions

Table 8.8 summarizes the registers of port 5.

Table 8.8 Port 5 Registers

Address*	Name	Abbreviation	R/W	Initial Value	
				Modes 1 to 4	Modes 5 to 7
H'EE004	Port 5 data direction register	P5DDR	W	H'FF	H'F0
H'FFFD4	Port 5 data register	P5DR	R/W	H'F0	H'F0
H'EE03F	Port 5 input pull-up control register	P5PCR	R/W	H'F0	H'F0

Note: * Lower 20 bits of the address in advanced mode.

Port 5 Data Direction Register (P5DDR): P5DDR is an 8-bit write-only register that can select input or output for each pin in port 5.

Bits 7 to 4 are reserved. They are fixed at 1, and cannot be modified.

Bit	7	6	5	4	3	2	1	0
	—	—	—	—	P5 ₃ DDR	P5 ₂ DDR	P5 ₁ DDR	P5 ₀ DDR
Modes 1 to 4	Initial value	1	1	1	1	1	1	1
	Read/Write	—	—	—	—	—	—	—
Modes 5 to 7	Initial value	1	1	1	0	0	0	0
	Read/Write	—	—	—	W	W	W	W

Reserved bits
Port 5 data direction 3 to 0
These bits select input or output for port 5 pins

Modes 1 to 4 (Expanded Modes with On-Chip ROM Disabled): P5DDR values are fixed at 1. Port 5 functions as an address bus.

Modes 5 (Expanded Modes with On-Chip ROM Enabled): Following a reset, port 5 is an input port. A pin in port 5 becomes an address output pin if the corresponding P5DDR bit is set to 1, and an input port if this bit is cleared to 0.

Mode 6 and 7 (Single-Chip Mode): Port 5 functions as an input/output port. A pin in port 5 becomes an output port if the corresponding P5DDR bit is set to 1, and an input port if this bit is cleared to 0.

In modes 1 to 4, P5DDR bits are always read as 1, and cannot be modified.

In modes 5 to 7, P5DDR is a write-only register. Its value cannot be read. All bits return 1 when read.

P5DDR is initialized to H'FF in modes 1 to 4, and to H'F0 in modes 5 to 7, by a reset and in hardware standby mode. In software standby mode it retains its previous setting. Therefore, if a transition is made to software standby mode while port 5 is functioning as an input/output port and a P5DDR bit is set to 1, the corresponding pin maintains its output state.

Port 5 Data Register (P5DR): P5DR is an 8-bit readable/writable register that stores output data for port 5. When port 5 functions as an output port, the value of this register is output. When a bit in P5DDR is set to 1, if port 5 is read the value of the corresponding P5DR bit is returned. When a bit in P5DDR is cleared to 0, if port 5 is read the corresponding pin logic level is read.

Bits 7 to 4 are reserved. They are fixed at 1, and cannot be modified.

Bit	7	6	5	4	3	2	1	0
	—	—	—	—	P5 ₃	P5 ₂	P5 ₁	P5 ₀
Initial value	1	1	1	1	0	0	0	0
Read/Write	—	—	—	—	R/W	R/W	R/W	R/W

Reserved bits
Port 5 data 3 to 0
These bits store data for port 5 pins

P5DR is initialized to H'F0 by a reset and in hardware standby mode. In software standby mode it retains its previous setting.

Port 5 Input Pull-Up MOS Control Register (P5PCR): P5PCR is an 8-bit readable/writable register that controls the MOS input pull-up transistors in port 5.

Bits 7 to 4 are reserved. They are fixed at 1, and cannot be modified.

Bit	7	6	5	4	3	2	1	0
	—	—	—	—	P5 ₃ PCR	P5 ₂ PCR	P5 ₁ PCR	P5 ₀ PCR
Initial value	1	1	1	1	0	0	0	0
Read/Write	—	—	—	—	R/W	R/W	R/W	R/W

Reserved bits
Port 5 input pull-up control 3 to 0
These bits control input pull-up transistors built into port 5

In modes 5 to 7, when a P5DDR bit is cleared to 0 (selecting generic input), if the corresponding bit in P5PCR is set to 1, the input pull-up transistor is turned on.

P5PCR is initialized to H'F0 by a reset and in hardware standby mode. In software standby mode it retains its previous setting.

Table 8.9 summarizes the states of the input pull-ups in each mode.

Table 8.9 Input Pull-Up Transistor States (Port 5)

Mode	Reset	Hardware Standby Mode	Software Standby Mode	Other Modes
1	Off	Off	Off	Off
2				
3				
4				
5	Off	Off	On/off	On/off
6				
7				

Legend

Off: The input pull-up transistor is always off.

On/off: The input pull-up transistor is on if P5PCR = 1 and P5DDR = 0. Otherwise, it is off.

8.7 Port 6

8.7.1 Overview

Port 6 is an 8-bit input/output port that is also used for input and output of bus control signals (\overline{LWR} , \overline{HWR} , \overline{RD} , \overline{AS} , \overline{BACK} , \overline{BREQ} , \overline{WAIT}) and for clock (ϕ) output.

In modes 1 to 5 (expanded modes), the pin functions are P6₇ (generic input)/ ϕ , \overline{LWR} , \overline{HWR} , \overline{RD} , \overline{AS} , P6₂/ \overline{BACK} , P6₁/ \overline{BREQ} , and P6₀/ \overline{WAIT} . See table 8.11 for the selection of the pin functions. In modes 6 and 7 (single-chip modes), P6₇ functions as a generic input port or ϕ output, and P6₆ to P6₀ function as generic input/output ports.

When DRAM is connected to areas 2 to 5, \overline{LWR} , \overline{HWR} , and \overline{RD} also function as \overline{LCAS} , \overline{UCAS} , and \overline{WE} , respectively. For details see section 6.5, DRAM Interface.

Pins in port 6 can drive one TTL load and a 90-pF capacitive load. They can also drive a darlington transistor pair.

Port 6 pins	Modes 1 to 5 (expanded modes)	Mode 6 and 7 (single-chip mode)
P6 ₇ / ϕ	P6 ₇ (input) / ϕ (output)	P6 ₇ (input) / ϕ (output)
P6 ₆ / \overline{LWR}	\overline{LWR} (output)	P6 ₆ (input/output)
P6 ₅ / \overline{HWR}	\overline{HWR} (output)	P6 ₅ (input/output)
P6 ₄ / \overline{RD}	\overline{RD} (output)	P6 ₄ (input/output)
P6 ₃ / \overline{AS}	\overline{AS} (output)	P6 ₃ (input/output)
P6 ₂ / \overline{BACK}	P6 ₂ (input/output) / \overline{BACK} (output)	P6 ₂ (input/output)
P6 ₁ / \overline{BREQ}	P6 ₁ (input/output) / \overline{BREQ} (input)	P6 ₁ (input/output)
P6 ₀ / \overline{WAIT}	P6 ₀ (input/output) / \overline{WAIT} (input)	P6 ₀ (input/output)

Figure 8.6 Port 6 Pin Configuration

8.7.2 Register Descriptions

Table 8.10 summarizes the registers of port 6.

Table 8.10 Port 6 Registers

Address*	Name	Abbreviation	R/W	Initial Value
H'EE005	Port 6 data direction register	P6DDR	W	H'80
H'FFFD5	Port 6 data register	P6DR	R/W	H'80

Note: * Lower 20 bits of the address in advanced mode.

Port 6 Data Direction Register (P6DDR): P6DDR is an 8-bit write-only register that can select input or output for each pin in port 6.

Bit 7 is reserved. It is fixed at 1, and cannot be modified.

Bit	7	6	5	4	3	2	1	0
	—	P6 ₆ DDR	P6 ₅ DDR	P6 ₄ DDR	P6 ₃ DDR	P6 ₂ DDR	P6 ₁ DDR	P6 ₀ DDR
Initial value	1	0	0	0	0	0	0	0
Read/Write	—	W	W	W	W	W	W	W

Reserved bit
Port 6 data direction 6 to 0
 These bits select input or output for port 6 pins

Modes 1 to 5 (Expanded Modes): P6₇ functions as the clock output pin (ϕ) or an input port. P6₇ is the clock output pin (ϕ) if the PSTOP bit in MSTRCH is cleared to 0 (initial value), and an input port if this bit is set to 1.

P6₆ to P6₃ function as bus control output pins ($\overline{\text{LWR}}$, $\overline{\text{HWR}}$, $\overline{\text{RD}}$, and $\overline{\text{AS}}$), regardless of the settings of bits P6₆DDR to P6₃DDR.

P6₂ to P6₀ function as bus control input/output pins ($\overline{\text{BACK}}$, $\overline{\text{BREQ}}$, and $\overline{\text{WAIT}}$) or input/output ports. For the method of selecting the pin functions, see table 8.11.

When P6₂ to P6₀ function as input/output ports, the pin becomes an output port if the corresponding P6DDR bit is set to 1, and an input port if this bit is cleared to 0.

Mode 6 and 7 (Single-Chip Mode): P6₇ functions as the clock output pin (ϕ) or an input port. P6₆ to P6₀ function as generic input/output ports. P6₇ is the clock output pin (ϕ) if the PSTOP bit in MSTRCH is cleared to 0 (initial value), and an input port if this bit is set to 1. A pin in port 6

becomes an output port if the corresponding bit of P6₀DDR to P6₇DDR is set to 1, and an input port if this pin is cleared to 0.

P6DDR is a write-only register. Its value cannot be read. All bits return 1 when read.

P6DDR is initialized to H'80 by a reset and in hardware standby mode. In software standby mode it retains its previous setting. Therefore, if a transition is made to software standby mode while port 6 is functioning as an input/output port and a P6DDR bit is set to 1, the corresponding pin maintains its output state.

Port 6 Data Register (P6DR): P6DR is an 8-bit readable/writable register that stores output data for port 6. When port 6 functions as an output port, the value of this register is output. For bit 7, a value of 1 is returned if the bit is read while the PSTOP bit in MSTRH is cleared to 0, and the P67 pin logic level is returned if the bit is read while the PSTOP bit is set to 1. Bit 7 cannot be modified. For bits 6 to 0, the pin logic level is returned if the bit is read while the corresponding bit in P6DDR is cleared to 0, and the P6DR value is returned if the bit is read while the corresponding bit in P6DDR is set to 1.

Bit	7	6	5	4	3	2	1	0
	P6 ₇	P6 ₆	P6 ₅	P6 ₄	P6 ₃	P6 ₂	P6 ₁	P6 ₀
Initial value	1	0	0	0	0	0	0	0
Read/Write	R	R/W	R/W	R/W	R/W	R/W	R/W	R/W

Port 6 data 7 to 0

These bits store data for port 6 pins

P6DR is initialized to H'80 by a reset and in hardware standby mode. In software standby mode it retains its previous setting.

Table 8.11 Port 6 Pin Functions in Modes 1 to 5

Pin	Pin Functions and Selection Method		
P6 ₇ /φ	Bit PSTOP in MSTCRH selects the pin function.		
	PSTOP	0	
	Pin function	φ output	
LWR	Functions as \overline{LWR} regardless of the setting of bit P6 ₈ DDR		
	P6 ₈ DDR	0	
	Pin function	\overline{LWR} output*	
Note: * If any of bits DRAS2 to DRAS0 in DRCRA is 1 and bit CSEL in DRCRB is 1, \overline{LWR} output functions as LCAS.			
HWR	Functions as \overline{HWR} regardless of the setting of bit P6 ₅ DDR		
	P6 ₅ DDR	0	
	Pin function	\overline{HWR} output*	
Note: * If any of bits DRAS2 to DRAS0 in DRCRA is 1 and bit CSEL in DRCRB is 1, \overline{HWR} output functions as \overline{UCAS} .			
\overline{RD}	Functions as \overline{RD} regardless of the setting of bit P6 ₄ DDR		
	P6 ₄ DDR	0	
	Pin function	\overline{RD} output*	
Note: * If any of bits DRAS2 to DRAS0 in DRCRA is 1, \overline{RD} output functions as \overline{WE} .			
\overline{AS}	Functions as \overline{AS} regardless of the setting of bit P6 ₃ DDR		
	P6 ₃ DDR	0	
	Pin function	\overline{AS} output	
P6 ₂ / \overline{BACK}	Bit BRLE in BR CR and bit P6 ₂ DDR select the pin function as follows		
	BRLE	0	
	P6 ₂ DDR	0	1
	Pin function	P6 ₂ input	P6 ₂ output
P6 ₁ / \overline{BREQ}	Bit BRLE in BR CR and bit P6 ₁ DDR select the pin function as follows		
	BRLE	0	
	P6 ₁ DDR	0	1
	Pin function	P6 ₁ input	P6 ₁ output
P6 ₀ / \overline{WAIT}	Bit WAITE in BCR and bit P6 ₀ DDR select the pin function as follows.		
	WAITE	0	
	P6 ₀ DDR	0	1
	Pin function	P6 ₀ input	P6 ₀ output
Note: * Do not set bit P6 ₀ DDR to 1.			

8.8 Port 7

8.8.1 Overview

Port 7 is an 8-bit input port that is also used for analog input to the A/D converter and analog output from the D/A converter. The pin functions are the same in all operating modes. Figure 8.7 shows the pin configuration of port 7.

See section 15, A/D Converter, for details of the A/D converter analog input pins, and section 16, D/A Converter, for details of the D/A converter analog output pins.

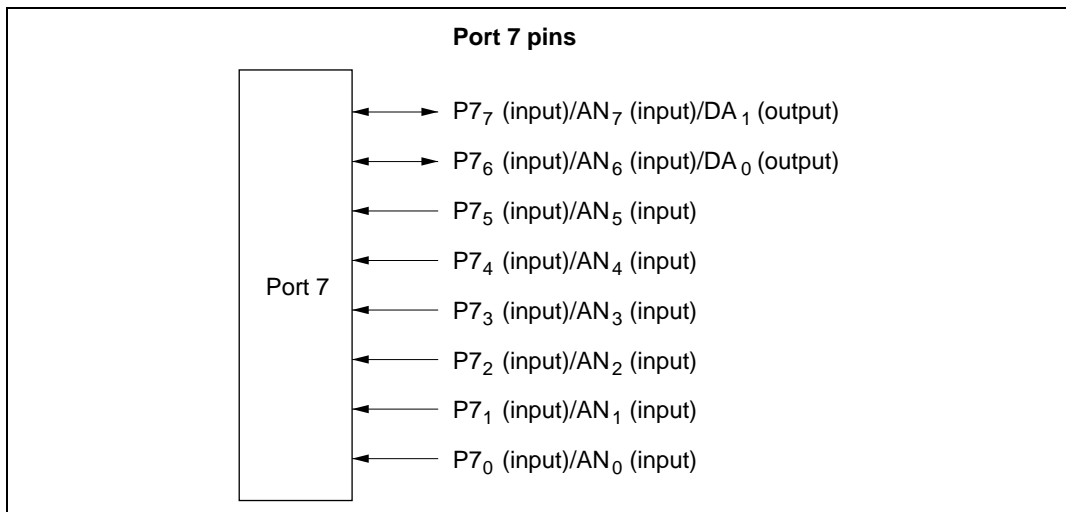

Figure 8.7 Port 7 Pin Configuration

8.8.2 Register Description

Table 8.12 summarizes the port 7 register. Port 7 is an input port, and port 7 has no data direction register.

Table 8.12 Port 7 Data Register

Address*	Name	Abbreviation	R/W	Initial Value
H'FFFD6	Port 7 data register	P7DR	R	Undetermined

Note: * Lower 20 bits of the address in advanced mode.

Port 7 Data Register (P7DR)

Bit	7	6	5	4	3	2	1	0
	P7 ₇	P7 ₆	P7 ₅	P7 ₄	P7 ₃	P7 ₂	P7 ₁	P7 ₀
Initial value	—*	—*	—*	—*	—*	—*	—*	—*
Read/Write	R	R	R	R	R	R	R	R

Note: * Determined by pins P7₇ to P7₀.

When port 7 is read, the pin logic levels are always read. P7DR cannot be modified.

8.9 Port 8

8.9.1 Overview

Port 8 is a 5-bit input/output port that is also used for \overline{CS}_3 to \overline{CS}_0 output, \overline{RFSH} output, \overline{IRQ}_3 to \overline{IRQ}_0 input, and A/D converter \overline{ADTRG} input. Figure 8.8 shows the pin configuration of port 8.

In modes 1 to 5 (expanded modes), port 8 can provide \overline{CS}_3 to \overline{CS}_0 output, \overline{RFSH} output, \overline{IRQ}_3 to \overline{IRQ}_0 input, and \overline{ADTRG} input. See table 8.14 for the selection of pin functions in expanded modes.

In modes 6 and 7 (single-chip modes), port 8 can provide \overline{IRQ}_3 to \overline{IRQ}_0 input and \overline{ADTRG} input. See table 8.15 for the selection of pin functions in single-chip mode.

See section 15, A/D Converter, for a description of the A/D converter's \overline{ADTRG} input pin.

The \overline{IRQ}_3 to \overline{IRQ}_0 functions are selected by IER settings, regardless of whether the pin is used for input or output. Caution is therefore required. For details see section 5.3.1, External Interrupts.

When DRAM is connected to areas 2 to 5, the \overline{CS}_3 and \overline{CS}_2 output pins function as \overline{RAS} output pins for each area. For details see section 6.5, DRAM Interface.

Pins in port 8 can drive one TTL load and a 90-pF capacitive load. They can also drive a darlington transistor pair.

Pins P8₂ to P8₀ have Schmitt-trigger inputs.

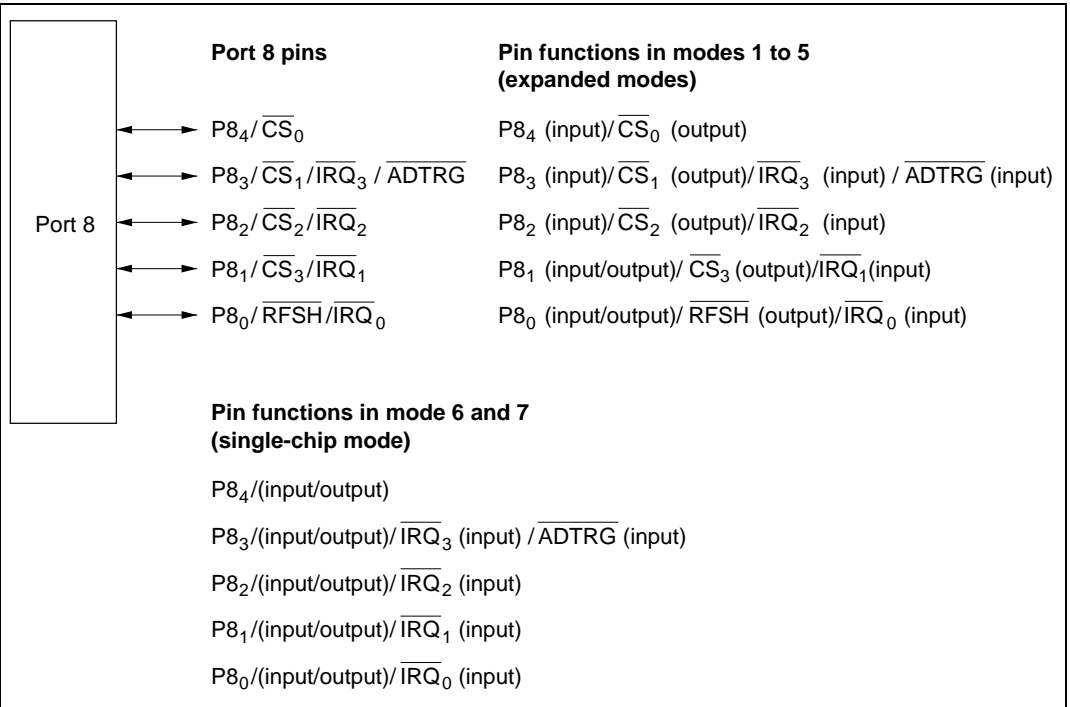

Figure 8.8 Port 8 Pin Configuration

8.9.2 Register Descriptions

Table 8.13 summarizes the registers of port 8.

Table 8.13 Port 8 Registers

Address*	Name	Abbreviation	R/W	Initial Value	
				Mode 1 to 4	Mode 5 to 7
H'EE007	Port 8 data direction register	P8DDR	W	H'F0	H'E0
H'FFFD7	Port 8 data register	P8DR	R/W	H'E0	H'E0

Note: * Lower 20 bits of the address in advanced mode.

Port 8 Data Direction Register (P8DDR): P8DDR is an 8-bit write-only register that can select input or output for each pin in port 8.

Bits 7 to 5 are reserved. They are fixed at 1, and cannot be modified.

Bit	7	6	5	4	3	2	1	0
	—	—	—	P8 ₄ DDR	P8 ₃ DDR	P8 ₂ DDR	P8 ₁ DDR	P8 ₀ DDR
Modes 1 to 4	Initial value	1	1	1	0	0	0	0
	Read/Write	—	—	—	W	W	W	W
Modes 5 to 7	Initial value	1	1	1	0	0	0	0
	Read/Write	—	—	—	W	W	W	W

Reserved bits

Port 8 data direction 4 to 0
These bits select input or output for port 8 pins

Modes 1 to 5 (Expanded Modes): When bits in P8DDR bit are set to 1, P8₄ to P8₁ become \overline{CS}_0 to \overline{CS}_3 output pins. When bits in P8DDR are cleared to 0, the corresponding pins become input ports. However, P8₁ can also be used as an output port, depending on the setting of bits DRAS2 to DRAS0 in DRAM control register A (DRCRA). For details see section 6.5.2, DRAM Space and \overline{RAS} Output Pin Settings.

In modes 1 to 4 (expanded modes with on-chip ROM disabled), following a reset P8₄ functions as the \overline{CS}_0 output, while \overline{CS}_1 to \overline{CS}_3 are input ports. In mode 5 (expanded mode with on-chip ROM enabled), following a reset \overline{CS}_0 to \overline{CS}_3 are all input ports.

When the refresh enable bit (RFSHE) in DRCRA is set to 1, P8₀ is used for $\overline{\text{RFSH}}$ output. When RFSHE is cleared to 0, P8₀ becomes an input/output port according to the P8DDR setting. For details see table 8.14.

Mode 6 and 7 (Single-Chip Mode): Port 8 is a generic input/output port. A pin in port 8 becomes an output port if the corresponding P8DDR bit is set to 1, and an input port if this bit is cleared to 0.

P8DDR is a write-only register. Its value cannot be read. All bits return 1 when read.

P8DDR is initialized to H'F0 in modes 1 to 4, and to H'E0 in modes 5 to 7, by a reset and in hardware standby mode. In software standby mode P8DDR retains its previous setting. Therefore, if a transition is made to software standby mode while port 8 is functioning as an input/output port and a P8DDR bit is set to 1, the corresponding pin maintains its output state.

Port 8 Data Register (P8DR): P8DR is an 8-bit readable/writable register that stores output data for port 8. When port 8 functions as an output port, the value of this register is output. When a bit in P8DDR is set to 1, if port 8 is read the value of the corresponding P8DR bit is returned. When a bit in P8DDR is cleared to 0, if port 8 is read the corresponding pin logic level is read.

Bits 7 to 5 are reserved. They are fixed at 1, and cannot be modified.

Bit	7	6	5	4	3	2	1	0
	—	—	—	P8 ₄	P8 ₃	P8 ₂	P8 ₁	P8 ₀
Initial value	1	1	1	0	0	0	0	0
Read/Write	—	—	—	R/W	R/W	R/W	R/W	R/W

Reserved bits
Port 8 data 4 to 0
These bits store data for port 8 pins

P8DR is initialized to H'E0 by a reset and in hardware standby mode. In software standby mode it retains its previous setting.

Table 8.14 Port 8 Pin Functions in Modes 1 to 5

Pin	Pin Functions and Selection Method	
$P8_4/\overline{CS}_0$	Bit $P8_4$ DDR selects the pin function as follows	
	$P8_4$ DDR	0 1
	Pin function	$P8_4$ input \overline{CS}_0 output
$P8_3/\overline{CS}_1/\overline{IRQ}_3/\overline{ADTRG}$	Bit $P8_3$ DDR selects the pin function as follows	
	$P8_3$ DDR	0 1
	Pin function	$P8_3$ input \overline{CS}_1 output
		\overline{IRQ}_3 input
		\overline{ADTRG} input
$P8_2/\overline{CS}_2/\overline{IRQ}_2$	The DRAM interface settings by bits DRAS2 to DRAS0 in DRCRA, and bit $P8_2$ DDR, select the pin function as follows.	
	DRAM interface settings	(1) in table below (2) in table below
	$P8_2$ DDR	0 1 —
	Pin function	$P8_2$ input \overline{CS}_2 output \overline{CS}_2 output*
		\overline{IRQ}_3 input
Note: * \overline{CS}_2 is output as \overline{RAS}_2 .		
DRAM interface setting	(1) (2)	
DRAS2	0 1	
DRAS1	0 1 0 1	
DRAS0	0 1 0 1 0 1 0 1	
$P8_1/\overline{CS}_3/\overline{IRQ}_1$	The DRAM interface settings by bits DRAS2 to DRAS0 in DRCRA, and bit $P8_1$ DDR, select the pin function as follows.	
	DRAM interface settings	(1) in table below (2) in table below (3) in table below
	$P8_1$ DDR	0 1 0 1 —
	Pin function	$P8_1$ input pin \overline{CS}_3 output pin $P8_1$ input pin $P8_1$ output pin \overline{CS}_3 output pin*
		\overline{IRQ}_1 input pin
Note: * \overline{CS}_3 is output as \overline{RAS}_3 .		
DRAM interface setting	(1) (3) (2) (3) (2)	
DRAS2	0 1	
DRAS1	0 1 0 1	
DRAS0	0 1 0 1 0 1 0 1	
$P8_0/\overline{RFSH}/\overline{IRQ}_0$	Bit RFSHE in DRCRA and bit $P8_0$ DDR select the pin function as follows.	
	RFSHE	0 1*
	$P8_0$ DDR	0 1 —
	Pin function	$P8_0$ input $P8_0$ output \overline{RFSH} output
		\overline{IRQ}_0 input
Note: * If areas 2 to 5 are not designated as DRAM space, this bit should not be set to 1.		

Table 8.15 Port 8 Pin Functions in Mode 6 and 7

Pin	Pin Functions and Selection Method		
P8 ₄	Bit P8 ₄ DDR selects the pin function as follows		
	P8 ₄ DDR	0	1
	Pin function	P8 ₄ input	P8 ₄ output
P8 ₃ / $\overline{\text{IRQ}}_3$ / $\overline{\text{ADTRG}}$	Bit P8 ₃ DDR selects the pin function as follows		
	P8 ₃ DDR	0	1
	Pin function	P8 ₃ input	P8 ₃ output
		$\overline{\text{IRQ}}_3$ input	
		$\overline{\text{ADTRG}}$ input	
P8 ₂ / $\overline{\text{IRQ}}_2$	Bit P8 ₂ DDR selects the pin function as follows		
	P8 ₂ DDR	0	1
	Pin function	P8 ₂ input	P8 ₂ output
		$\overline{\text{IRQ}}_2$ input	
P8 ₁ / $\overline{\text{IRQ}}_1$	Bit P8 ₁ DDR selects the pin function as follows		
	P8 ₁ DDR	0	1
	Pin function	P8 ₁ input	P8 ₁ output
		$\overline{\text{IRQ}}_1$ input	
P8 ₀ / $\overline{\text{IRQ}}_0$	Bit P8 ₀ DDR select the pin function as follows		
	P8 ₀ DDR	0	1
	Pin function	P8 ₀ input	P8 ₀ output
		$\overline{\text{IRQ}}_0$ input	

8.10 Port 9

8.10.1 Overview

Port 9 is a 6-bit input/output port that is also used for input and output (TxD₀, TxD₁, RxD₀, RxD₁, SCK₀, SCK₁) by serial communication interface channels 0 and 1 (SCI0 and SCI1), and for $\overline{\text{IRQ}}_5$ and $\overline{\text{IRQ}}_4$ input. See table 8.17 for the selection of pin functions.

The $\overline{\text{IRQ}}_5$ and $\overline{\text{IRQ}}_4$ functions are selected by IER settings, regardless of whether the pin is used for input or output. Caution is therefore required. For details see section 5.3.1, External Interrupts.

Port 9 has the same set of pin functions in all operating modes. Figure 8.9 shows the pin configuration of port 9.

Pins in port 9 can drive one TTL load and a 30-pF capacitive load. They can also drive a darlington transistor pair.

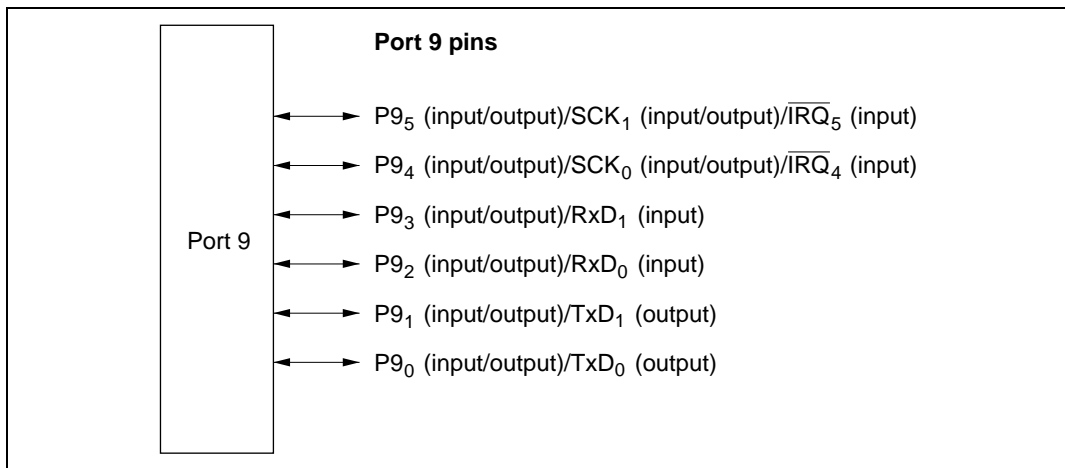

Figure 8.9 Port 9 Pin Configuration

8.10.2 Register Descriptions

Table 8.16 summarizes the registers of port 9.

Table 8.16 Port 9 Registers

Address*	Name	Abbreviation	R/W	Initial Value
H'EE008	Port 9 data direction register	P9DDR	W	H'C0
H'FFFD8	Port 9 data register	P9DR	R/W	H'C0

Note: * Lower 20 bits of the address in advanced mode.

Port 9 Data Direction Register (P9DDR): P9DDR is an 8-bit write-only register that can select input or output for each pin in port 9.

Bits 7 and 6 are reserved. They are fixed at 1, and cannot be modified.

Bit	7	6	5	4	3	2	1	0
	—	—	P9 ₅ DDR	P9 ₄ DDR	P9 ₃ DDR	P9 ₂ DDR	P9 ₁ DDR	P9 ₀ DDR
Initial value	1	1	0	0	0	0	0	0
Read/Write	—	—	W	W	W	W	W	W

Reserved bits
Port 9 data direction 5 to 0
These bits select input or output for port 9 pins

When port 9 functions as an input/output port, a pin in port 9 becomes an output port if the corresponding P9DDR bit is set to 1, and an input port if this bit is cleared to 0. For the method of selecting the pin functions, see table 8.17.

P9DDR is a write-only register. Its value cannot be read. All bits return 1 when read.

P9DDR is initialized to H'C0 by a reset and in hardware standby mode. In software standby mode it retains its previous setting. Therefore, if a transition is made to software standby mode while port 9 is functioning as an input/output port and a P9DDR bit is set to 1, the corresponding pin maintains its output state.

Port 9 Data Register (P9DR): P9DR is an 8-bit readable/writable register that stores output data for port 9. When port 9 functions as an output port, the value of this register is output. When a bit in P9DDR is set to 1, if port 9 is read the value of the corresponding P9DR bit is returned. When a bit in P9DDR is cleared to 0, if port 9 is read the corresponding pin logic level is read.

Bits 7 and 6 are reserved. They are fixed at 1, and cannot be modified.

Bit	7	6	5	4	3	2	1	0
	—	—	P9 ₅	P9 ₄	P9 ₃	P9 ₂	P9 ₁	P9 ₀
Initial value	1	1	0	0	0	0	0	0
Read/Write	—	—	R/W	R/W	R/W	R/W	R/W	R/W

Reserved bits
Port 9 data 5 to 0
These bits store data
for port 9 pins

P9DR is initialized to H'C0 by a reset and in hardware standby mode. In software standby mode it retains its previous setting.

Table 8.17 Port 9 Pin Functions

Pin	Pin Functions and Selection Method				
$P9_5/SCK_1/\overline{IRQ}_5$	Bit C/\overline{A} in SMR of SCI1, bits CKE0 and CKE1 in SCR, and bit $P9_5DDR$ select the pin function as follows				
CKE1	0			1	
C/\overline{A}	0		1	—	
CKE0	0	1	—	—	
$P9_5DDR$	0	1	—	—	
Pin function	$P9_5$ input	$P9_5$ output	SCK_1 output	SCK_1 output	SCK_1 input
	\overline{IRQ}_5 input				
$P9_4/SCK_0/\overline{IRQ}_4$	Bit C/\overline{A} in SMR of SCI0, bits CKE0 and CKE1 in SCR, and bit $P9_4DDR$ select the pin function as follows				
CKE1	0			1	
C/\overline{A}	0		1	—	
CKE0	0	1	—	—	
$P9_4DDR$	0	1	—	—	
Pin function	$P9_4$ input	$P9_4$ output	SCK_0 output	SCK_0 output	SCK_0 input
	\overline{IRQ}_4 input				
$P9_3/RxD_1$	Bit RE in SCR of SCI1, bit SMIF in SCMR, and bit $P9_3DDR$ select the pin function as follows.				
SMIF	0			1	
RE	0		1	—	
$P9_3DDR$	0	1	—	—	
Pin function	$P9_3$ input	$P9_3$ output	RxD_1 input	RxD_1 input	
$P9_2/RxD_0$	Bit RE in SCR of SCI0, bit SMIF in SCMR, and bit $P9_2DDR$ select the pin function as follows				
SMIF	0			1	
RE	0		1	—	
$P9_2DDR$	0	1	—	—	
Pin function	$P9_2$ input	$P9_2$ output	RxD_0 input	RxD_0 input	

Pin Pin Functions and Selection MethodP9₁/TxD₁Bit TE in SCR of SCI1, bit SMIF in SCMR, and bit P9₁DDR select the pin function as follows.

SMIF	0			1
TE	0		1	—
P9 ₁ DDR	0	1	—	—
Pin function	P9 ₁ input	P9 ₁ output	TxD ₁ output	TxD ₁ output*

Note: * Functions as the TxD₁ output pin, but there are two states: one in which the pin is driven, and another in which the pin is at high-impedance.

P9₀/TxD₀Bit TE in SCR of SCI0, bit SMIF in SCMR, and bit P9₀DDR select the pin function as follows.

SMIF	0			1
TE	0		1	—
P9 ₀ DDR	0	1	—	—
Pin function	P9 ₀ input	P9 ₀ output	TxD ₀ output	TxD ₀ output*

Note: * Functions as the TxD₀ output pin, but there are two states: one in which the pin is driven, and another in which the pin is at highimpedance.

8.11 Port A

8.11.1 Overview

Port A is an 8-bit input/output port that is also used for output (TP₇ to TP₀) from the programmable timing pattern controller (TPC), input and output, (TIOCB₂, TIOCA₂, TIOCB₁, TIOCA₁, TIOCB₀, TIOCA₀, TCLKD, TCLKC, TCLKB, TCLKA) by the 16-bit timer, input (TCLKD, TCLKC, TCLKB, TCLKA) to the 8-bit timer, output ($\overline{\text{TEND}}_1$, $\overline{\text{TEND}}_0$) from the DMA controller (DMAC), and address output (A₂₃ to A₂₀). A reset or hardware standby transition leaves port A as an input port, except that in modes 3 and 4, one pin is always used for A₂₀ output. See table 8.19 to 8.21 for the selection of pin functions.

Usage of pins for TPC, 16-bit timer, 8-bit timer, and DMAC input and output is described in the sections on those modules. For output of address bits A₂₃ to A₂₀ in modes 3, 4, and 5, see section 6.2.4, Bus Release Control Register (BRCR). Pins not assigned to any of these functions are available for generic input/output. Figure 8.10 shows the pin configuration of port A.

Pins in port A can drive one TTL load and a 30-pF capacitive load. They can also drive a darlington transistor pair. Port A has Schmitt-trigger inputs.

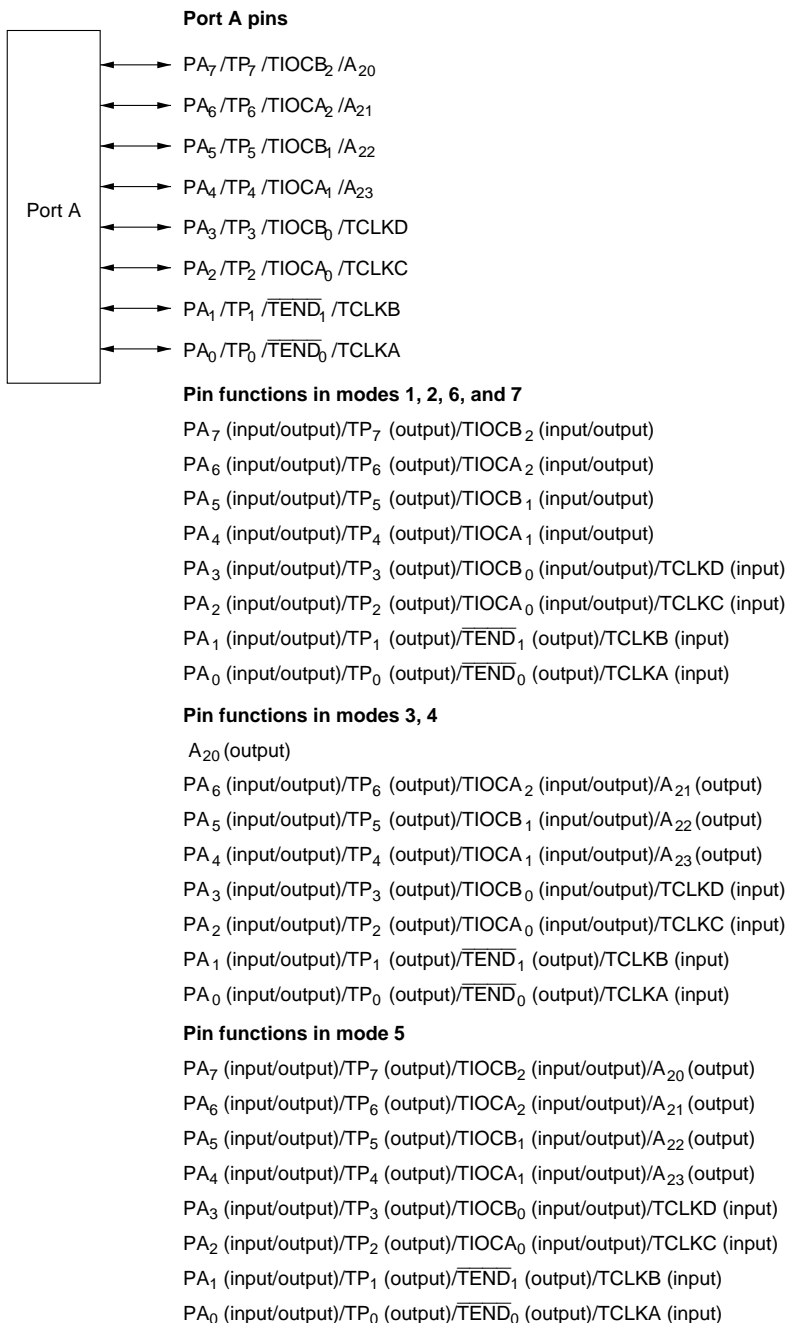
**Figure 8.10 Port A Pin Configuration**

8.11.2 Register Descriptions

Table 8.18 summarizes the registers of port A.

Table 8.18 Port A Registers

Address*	Name	PADDR	R/W	Initial Value	
				Modes 1, 2, 5, 6, and 7	Modes 3, 4
H'EE009	Port A data direction register	PADDR	W	H'00	H'80
H'FFFD9	Port A data register	PADR	R/W	H'00	H'00

Note: * Lower 20 bits of the address in advanced mode.

Port A Data Direction Register (PADDR): PADDR is an 8-bit write-only register that can select input or output for each pin in port A. When pins are used for TPC output, the corresponding PADDR bits must also be set.

Bit								
	7	6	5	4	3	2	1	0
	PA ₇ DDR	PA ₆ DDR	PA ₅ DDR	PA ₄ DDR	PA ₃ DDR	PA ₂ DDR	PA ₁ DDR	PA ₀ DDR
Modes 3, 4	Initial value	1	0	0	0	0	0	0
	Read/Write	—	W	W	W	W	W	W
Modes 1, 2, 5, 6 and 7	Initial value	0	0	0	0	0	0	0
	Read/Write	W	W	W	W	W	W	W

Port A data direction 7 to 0

These bits select input or output for port A pins

The pin functions that can be selected for pins PA₇ to PA₄ differ between modes 1, 2, 6, and 7, and modes 3 to 5. For the method of selecting the pin functions, see tables 8.19 and 8.20.

The pin functions that can be selected for pins PA₃ to PA₀ are the same in modes 1 to 7. For the method of selecting the pin functions, see table 8.21.

When port A functions as an input/output port, a pin in port A becomes an output port if the corresponding PADDR bit is set to 1, and an input port if this bit is cleared to 0. In modes 3 and 4, PA₇DDR is fixed at 1 and PA₇ functions as the A₂₀ address output pin.

PADDR is a write-only register. Its value cannot be read. All bits return 1 when read.

PADDR is initialized to H'00 by a reset and in hardware standby mode in modes 1, 2, 5, 6, and 7. It is initialized to H'80 by a reset and in hardware standby mode in modes 3 and 4. In software standby mode it retains its previous setting. Therefore, if a transition is made to software standby mode while port A is functioning as an input/output port and a PADDR bit is set to 1, the corresponding pin maintains its output state.

Port A Data Register (PADR): PADR is an 8-bit readable/writable register that stores output data for port A. When port A functions as an output port, the value of this register is output. When a bit in PADDR is set to 1, if port A is read the value of the corresponding PADR bit is returned. When a bit in PADDR is cleared to 0, if port A is read the corresponding pin logic level is read.

Bit	7	6	5	4	3	2	1	0
	PA ₇	PA ₆	PA ₅	PA ₄	PA ₃	PA ₂	PA ₁	PA ₀
Initial value	0	0	0	0	0	0	0	0
Read/Write	R/W	R/W	R/W	R/W	R/W	R/W	R/W	R/W

Port A data 7 to 0

These bits store data for port A pins

PADR is initialized to H'00 by a reset and in hardware standby mode. In software standby mode it retains its previous setting.

Table 8.19 Port A Pin Functions (Modes 1, 2, 6, 7)**Pin Pin Functions and Selection Method**

PA₇/TP₇/TIOCB₂ Bit PWM2 in TMDR, bits IOB2 to IOB0 in TIOR2, bit NDER7 in NDERA, and bit PA₇DDR select the pin function as follows.

16-bit timer channel 2 settings	(1) in table below	(2) in table below		
PA ₇ DDR	—	0	1	1
NDER7	—	—	0	1
Pin function	TIOCB ₂ output	PA ₇ input	PA ₇ output	TP ₇ output
		TIOCB ₂ input*		

Note: * TIOCB₂ input when IOB2 = 1 and PWM2 = 0.

16-bit timer channel 2 settings	(2)	(1)		(2)
IOB2	0			1
IOB1	0	0	1	—
IOB0	0	1	—	—

Pin Pin Functions and Selection Method

PA₆/TP₆/
TIOCA₂ Bit PWM2 in TMDR, bits IOA2 to IOA0 in TIOR2, bit NDER6 in NDERA, and bit PA₆DDR select the pin function as follows.

16-bit timer channel 2 settings	(1) in table below	(2) in table below		
PA ₆ DDR	—	0	1	1
NDER6	—	—	0	1
Pin function	TIOCA ₂ output	PA ₆ input	PA ₆ output	TP ₆ output
		TIOCA ₂ input*		

Note: * TIOCA₂ input when IOA2 = 1.

16-bit timer channel 2 settings	(2)	(1)		(2)	(1)
PWM2	0				1
IOA2	0		1		—
IOA1	0	0	1	—	—
IOA0	0	1	—	—	—

PA₅/TP₅/
TIOCB₁ Bit PWM1 in TMDR, bits IOB2 to IOB0 in TIOR1, bit NDER5 in NDERA, and bit PA₅DDR select the pin function as follows.

16-bit timer channel 1 settings	(1) in table below	(2) in table below		
PA ₅ DDR	—	0	1	1
NDER5	—	—	0	1
Pin function	TIOCB ₁ output	PA ₅ input	PA ₅ output	TP ₅ output
		TIOCB ₁ input*		

Note: * TIOCB₁ input when IOB2 = 1 and PWM1 = 0.

16-bit timer channel 1 settings	(2)	(1)		(2)
IOB2	0			1
IOB1	0	0	1	—
IOB0	0	1	—	—

Pin Pin Functions and Selection Method

PA₄/TP₄/
TIOCA₁ Bit PWM1 in TMDR, bits IOA2 to IOA0 in TIOR1, bit NDER4 in NDERA, and bit PA₄DDR select the pin function as follows.

16-bit timer channel 1 settings	(1) in table below	(2) in table below		
PA ₄ DDR	—	0	1	1
NDER4	—	—	0	1
Pin function	TIOCA ₁ output	PA ₄ input	PA ₄ output	TP ₄ output
		TIOCA ₁ input*		

Note: * TIOCA₁ input when IOA2 = 1.

16-bit timer channel 1 settings	(2)	(1)		(2)	(1)
PWM1	0				1
IOA2	0			1	—
IOA1	0	0	1	—	—
IOA0	0	1	—	—	—

Table 8.20 Port A Pin Functions (Modes 3, 4, 5)**Pin Pin Functions and Selection Method**PA₇/TP₇/ Modes 3 and 4: Always used as A₂₀ output.

TIOCB ₂ / A ₂₀	Pin function	A ₂₀ output			
--------------------------------------	--------------	------------------------	--	--	--

Mode 5:

Bit PWM2 in TMDR, bits IOB2 to IOB0 in TIOR2, bit NDER7 in NDERA, bit A20E in BRCCR, and bit PA₇DDR select the pin function as follows.

A20E	1				0
16-bit timer channel 2 settings	(1) in table below	(2) in table below			—
PA ₇ DDR	—	0	1	1	—
NDER7	—	—	0	1	—
Pin function	TIOCB ₂ output	PA ₇ input	PA ₇ output	TP ₇ output	A ₂₀ output
		TIOCB ₂ input*			

Note: * TIOCB₂ input when IOB2 = 1 and PWM2 = 0.

16-bit timer channel 2 settings	(2)	(1)		(2)
IOB2	0			1
IOB1	0	0	1	—
IOB0	0	1	—	—

PA₆/TP₆/ Bit PWM2 in TMDR, bits IOA2 to IOA0 in TIOR2, bit NDER6 in NDERA, bit A21E in BRCCR, and bit PA₆DDR
TIOCA₂/A₂₁ select the pin function as follows.

A21E	1				0
16-bit timer channel 2 settings	(1) in table below	(2) in table below			—
PA ₆ DDR	—	0	1	1	—
NDER6	—	—	0	1	—
Pin function	TIOCA ₂ output	PA ₆ input	PA ₆ output	TP ₆ output	A ₂₁ output
		TIOCA ₂ input*			

Note: * TIOCA₂ input when IOA2 = 1.

16-bit timer channel 2 settings	(2)	(1)		(2)	(1)
PWM2	0				1
IOA2	0			1	—
IOA1	0	0	1	—	—
IOA0	0	1	—	—	—

Pin Pin Functions and Selection Method

PA₅/TP₅/
TIOCB₁/A₂₂ Bit PWM1 in TMDR, bits IOB2 to IOB0 in TIOR1, bit NDER5 in NDERA, bit A22E in BRCCR, and bit PA₅DDR select the pin function as follows.

A22E	1				0
16-bit timer channel 1 settings	(1) in table below	(2) in table below			—
PA ₅ DDR	—	0	1	1	—
NDER5	—	—	0	1	—
Pin function	TIOCB ₁ output	PA ₅ input	PA ₅ output	TP ₅ output	A ₂₂ output
		TIOCB ₁ input*			

Note: * TIOCB₁ input when IOB2 = 1 and PWM1 = 0.

16-bit timer channel 1 settings	(2)	(1)		(2)
IOB2	0			1
IOB1	0	0	1	—
IOB0	0	1	—	—

PA₄/TP₄/
TIOCA₁/A₂₃ Bit PWM1 in TMDR, bits IOA2 to IOA0 in TIOR1, bit NDER4 in NDERA, bit A23E in BRCCR, and bit PA₄DDR select the pin function as follows.

A23E	1				0
16-bit timer channel 1 settings	(1) in table below	(2) in table below			—
PA ₄ DDR	—	0	1	1	—
NDER4	—	—	0	1	—
Pin function	TIOCA ₁ output	PA ₄ input	PA ₄ output	TP ₄ output	A ₂₃ output
		TIOCA ₁ input*			

Note: * TIOCA₁ input when IOA2 = 1.

16-bit timer channel 1 settings	(2)	(1)	(2)	(1)
PWM1	0			1
IOA2	0		1	—
IOA1	0	0	1	—
IOA0	0	1	—	—

Table 8.21 Port A Pin Functions (Modes 1 to 7)**Pin Pin Functions and Selection Method**

PA₃/TP₃/
TIOCB₀/
TCLKD

Bit PWM0 in TMDR, bits IOB2 to IOB0 in TIOR0, bits TPSC2 to TPSC0 in 16TCR2 to 16TCR0 of the 16-bit timer, bits CKS2 to CKS0 in 8TCR2 of the 8-bit timer, bit NDER3 in NDERA, and bit PA₃DDR select the pin function as follows.

16-bit timer channel 0 settings	(1) in table below	(2) in table below		
PA ₃ DDR	—	0	1	1
NDER3	—	—	0	1
Pin function	TIOCB ₀ output	PA ₃ input	PA ₃ output	TP ₃ output
		TIOCB ₀ input* ¹		
	TCLKD input* ²			

- Notes: 1. TIOCB₀ input when IOB2 = 1 and PWM0 = 0.
2. TCLKD input when TPSC2 = TPSC1 = TPSC0 = 1 in any of 16TCR2 to 16TCR0, or bits CKS2 to CKS0 in 8TCR2 are as shown in (3) in the table below.

16-bit timer channel 0 settings	(2)	(1)		(2)
IOB2	0			1
IOB1	0	0	1	—
IOB0	0	1	—	—

8-bit timer channel 2 settings	(4)	(3)		
CKS2	0	1		
CKS1	—	0		1
CKS0	—	0	1	—

Pin Pin Functions and Selection Method

PA₂/TP₂/
TIOCA₀/
TCLKC

Bit PWM0 in TMDR, bits IOA2 to IOA0 in TIOR0, bits TPSC2 to TPSC0 in 16TCR2 to 16TCR0 of the 16-bit timer, bits CKS2 to CKS0 in 8TCR0 of the 8-bit timer, bit NDER2 in NDERA, and bit PA₂DDR select the pin function as follows.

16-bit timer channel 0 settings	(1) in table below	(2) in table below		
PA ₂ DDR	—	0	1	1
NDER2	—	—	0	1
Pin function	TIOCA ₀ output	PA ₂ input	PA ₂ output	TP ₂ output
		TIOCA ₀ input* ¹		
		TCLKC input* ²		

- Notes:
1. TIOCA₀ input when IOA2 = 1.
 2. TCLKC input when TPSC2 = TPSC1 = 1 and TPSC0 = 0 in any of 16TCR2 to 16TCR0, or bits CKS2 to CKS0 in 8TCR0 are as shown in (3) in the table below.

16-bit timer channel 0 settings	(2)	(1)		(2)	(1)
PWM0	0				1
IOA2	0			1	—
IOA1	0	0	1	—	—
IOA0	0	1	—	—	—

8-bit timer channel 0 settings	(4)		(3)	
CKS2	0	1		
CKS1	—	0		1
CKS0	—	0	1	—

Pin Pin Functions and Selection Method

PA_i/TP_i/
TCLKB/
 $\overline{\text{TEND}}_1$

Bit MDF in TMDR, bits TPSC2 to TPSC0 in 16TCR2 to 16TCR0 of the 16-bit timer, bits CKS2 to CKS0 in 8TCR3 of the 8-bit timer, bit NDER1 in NDERA, and bit PA_iDDR select the pin function as follows.

PA _i DDR	0	1	1
NDER1	—	0	1
Pin function	PA _i input	PA _i output	TP _i output
	TCLKB output* ¹		
	$\overline{\text{TEND}}_1$ output* ²		

- Notes:
1. TCLKB input when MDF = 1 in TMDR, or TPSC2 = 1, TPSC1 = 0, and TPSC0 = 1 in any of 16TCR2 to 16TCR0, or bits CKS2 to CKS0 in 8TCR3 are as shown in (1) in the table below.
 2. When an external request is specified as a DMAC activation source, $\overline{\text{TEND}}_1$ output regardless of bits PA_iDDR and NDER1.

8-bit timer channel 3 settings	(2)		(1)	
CKS2	0	1		
CKS1	—	0	1	
CKS0	—	0	1	—

PA₀/TP₀/
TCLKA/
 $\overline{\text{TEND}}_0$

Bit MDF in TMDR, bits TPSC2 to TPSC0 in 16TCR2 to 16TCR0 of the 16-bit timer, bits CKS2 to CKS0 in 8TCR1 of the 8-bit timer, bit NDER0 in NDERA, and bit PA₀DDR select the pin function as follows.

PA ₀ DDR	0	1	
NDER0	—	0	1
Pin function	PA ₀ input	PA ₀ output	TP ₀ output
	TCLKA output* ¹		
	$\overline{\text{TEND}}_0$ output* ²		

- Notes:
1. TCLKA input when MDF = 1 in TMDR, or TPSC2 = 1, TPSC1 = 0 and TPSC0 = 0 in any of 16TCR2 to 16TCR0, or bits CKS2 to CKS0 in 8TCR0 are as shown in (1) in the table below.
 2. When an external request is specified as a DMAC activation source, $\overline{\text{TEND}}_0$ output regardless of bits PA₀DDR and NDER0.

8-bit timer channel 1 settings	(2)		(1)	
CKS2	0	1		
CKS1	—	0	1	
CKS0	—	0	1	—

8.12 Port B

8.12.1 Overview

Port B is an 8-bit input/output port that is also used for output (TP₁₅ to TP₈) from the programmable timing pattern controller (TPC), input/output (TMIO₃, TMO₂, TMIO₁, TMO₀) by the 8-bit timer, \overline{CS}_7 to \overline{CS}_4 output, input (\overline{DREQ}_1 , \overline{DREQ}_0) to the DMA controller (DMAC), input and output (Tx_{D2}, Rx_{D2}, SCK₂) by serial communication interface channel 2 (SCI2), and output (\overline{UCAS} , \overline{LCAS}) by the DRAM interface. See table 8.23 to 8.24 for the selection of pin functions. A reset or hardware standby transition leaves port B as an input port.

For output of \overline{CS}_7 to \overline{CS}_4 in modes 1 to 5, see section 6.3.4, Chip Select Signals. When DRAM is connected to areas 2, 3, 4, and 5, the \overline{CS}_4 and \overline{CS}_5 output pins become \overline{RAS} output pins for these areas. For details see section 6.5, DRAM Interface. Pins not assigned to any of these functions are available for generic input/output. Figure 8.11 shows the pin configuration of port B.

When DRAM is connected to areas 2, 3, 4, and 5, the \overline{CS}_4 and \overline{CS}_5 output pins become \overline{RAS} output pins for these areas. For details see 6.5, DRAM Interface.

Pins in port B can drive one TTL load and a 30-pF capacitive load. They can also drive darlington transistor pair.

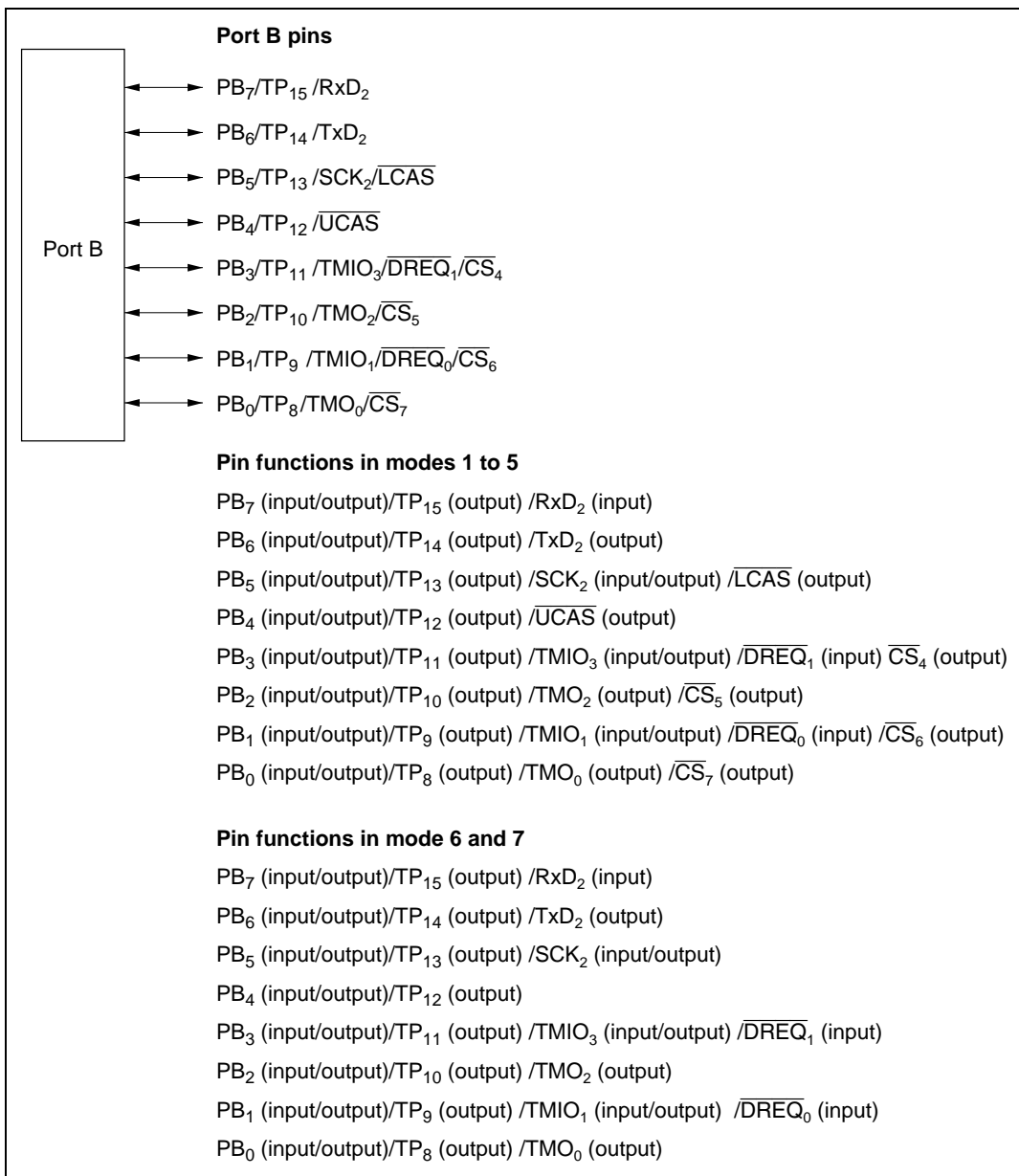

Figure 8.11 Port B Pin Configuration

8.12.2 Register Descriptions

Table 8.22 summarizes the registers of port B.

Table 8.22 Port B Registers

Address*	Name	Abbreviation	R/W	Initial Value
H'EE00A	Port B data direction register	PBDDR	W	H'00
H'FFFDA	Port B data register	PBDR	R/W	H'00

Note: * Lower 20 bits of the address in advanced mode.

Port B Data Direction Register (PBDDR): PBDDR is an 8-bit write-only register that can select input or output for each pin in port B. When pins are used for TPC output, the corresponding PBDDR bits must also be set.

Bit	7	6	5	4	3	2	1	0
	PB ₇ DDR	PB ₆ DDR	PB ₅ DDR	PB ₄ DDR	PB ₃ DDR	PB ₂ DDR	PB ₁ DDR	PB ₀ DDR
Initial value	0	0	0	0	0	0	0	0
Read/Write	W	W	W	W	W	W	W	W

Port B data direction 7 to 0

These bits select input or output for port B pins

The pin functions that can be selected for port B differ between modes 1 to 5, and modes 6 and 7. For the method of selecting the pin functions, see tables 8.23 and 8.24.

When port B functions as an input/output port, a pin in port B becomes an output port if the corresponding PBDDR bit is set to 1, and an input port if this bit is cleared to 0.

PBDDR is a write-only register. Its value cannot be read. All bits return 1 when read.

PBDDR is initialized to H'00 by a reset and in hardware standby mode. In software standby mode it retains its previous setting. Therefore, if a transition is made to software standby mode while port B is functioning as an input/output port and a PBDDR bit is set to 1, the corresponding pin maintains its output state.

Port B Data Register (PBDR): PBDR is an 8-bit readable/writable register that stores output data for pins port B. When port B functions as an output port, the value of this register is output. When a bit in PBDDR is set to 1, if port B is read the value of the corresponding PBDR bit is returned. When a bit in PBDDR is cleared to 0, if port B is read the corresponding pin logic level is read.

Bit	7	6	5	4	3	2	1	0
	PB ₇	PB ₆	PB ₅	PB ₄	PB ₃	PB ₂	PB ₁	PB ₀
Initial value	0	0	0	0	0	0	0	0
Read/Write	R/W	R/W	R/W	R/W	R/W	R/W	R/W	R/W

Port B data 7 to 0

These bits store data for port B pins

PBDR is initialized to H'00 by a reset and in hardware standby mode. In software standby mode it retains its previous setting.

Table 8.23 Port B Pin Functions (Modes 1 to 5)**Pin Pin Functions and Selection Method**

PB₇/TP₁₅/Rx_{D2} Bit RE in SCR of SCI2, bit SMIF in SCMR, bit NDER15 in NDERB, and bit PB₇DDR select the pin function as follows.

SMIF	0				1
RE	0			1	—
PB ₇ DDR	0	1	1	—	—
NDER15	—	0	1	—	—
Pin function	PB ₇ input	PB ₇ output	TP ₁₅ output	RxD ₂ input	RxD ₂ input

PB₆/TP₁₄/Tx_{D2} Bit TE in SCR of SCI2, bit SMIF in SCMR, bit NDER14 in NDERB, and bit PB₆DDR select the pin function as follows.

SMIF	0				1
TE	0			1	—
PB ₆ DDR	0	1	1	—	—
NDER14	—	0	1	—	—
Pin function	PB ₆ input	PB ₆ output	TP ₁₄ output	TxD ₂ output	TxD ₂ output*

Note: * Functions as the TxD₂ output pin, but there are two states: one in which the pin is driven, and another in which the pin is at high-impedance.

PB₅/TP₁₃/SCK₂/LCAS Bit C/ \bar{A} in SMR of SCI2, bits CKE0 and CKE1 in SCR, bit NDER13 in NDERB, and bit PB₅DDR select the pin function as follows.

CKE1	0				1
C/ \bar{A}	0			1	—
CKE0	0		1	—	—
PB ₅ DDR	0	1	1	—	—
NDER13	—	0	1	—	—
Pin function	PB ₅ input	PB ₅ output	TP ₁₃ output	SCK ₂ output	SCK ₂ output
	LCAS output*				

Note: * LCAS output depending on bits DRAS2 to DRAS0 in DRCRA and bit CSEL in DRCRB, and regardless of bits C/ \bar{A} , CKE0, and CKE1, NDER13, and PB₅DDR. For details, see section 6, Bus Controller.

PB₄/TP₁₂/UCAS Bit NDER12 in NDERB and bit PB₄DDR select the pin function as follows.

PB ₄ DDR	0	1	1
NDER12	—	0	1
Pin function	PB ₄ input	PB ₄ output	TP ₁₂ output
	UCAS output*		

Note: * UCAS output depending on bits DRAS2 to DRAS0 in DRCRA and bit CSEL in DRCRB, and regardless of bits NDER12 and PB₄DDR. For details, see section 6, Bus Controller.

Pin Pin Functions and Selection Method

$PB_3/TP_{11}/$ The DRAM interface settings by bits DRAS2 to DRAS0 in DRCRA, bits OIS3/2 and OS1/0 in 8TCSR3, bits
 $TMIO_3/$ CCLR1 and CCLR0 in 8TCR3, bit CS4E in CSCR, bit NDER11 in NDERB, and bit PB_3 DDR select the pin
 $\overline{DREQ}_1/\overline{CS}_4$ function as follows.

DRAM interface settings	(1) in table below					(2) in table below
OIS3/2 and OS1/0	All 0				Not all 0	—
CS4E	0		1		—	—
PB_3 DDR	0	1	1	—	—	—
NDER11	—	0	1	—	—	—
Pin function	PB_3 input	PB_3 output	TP_{11} output	\overline{CS}_4 output	$TMIO_3$ output	\overline{CS}_4 output* ³
	$TMIO_3$ input* ¹					
	\overline{DREQ}_1 input* ²					

- Notes:
1. $TMIO_3$ input when CCLR1 = CCLR0 = 1.
 2. When an external request is specified as a DMAC activation source, \overline{DREQ}_1 input regardless of bits OIS3 and OIS2, OS1 and OS0, CCLR1 and CCLR0, CS4E, NDER11, and PB_3 DDR.
 3. \overline{CS}_4 is output as \overline{RAS}_4 .

DRAM interface settings	(1)				(2)			(1)
DRAS2	0				1			
DRAS1	0		1		0		1	
DRAS0	0	1	0	1	0	1	0	1

$PB_2/TP_{10}/$ The DRAM interface settings by bits DRAS2 to DRAS0 in DRCRA, bits OIS3/2 and OS1/0 in 8TCSR2, bit
 $TMIO_2/\overline{CS}_5$ CS5E in CSCR, bit NDER10 in NDERB, and bit PB_2 DDR select the pin function as follows.

DRAM interface settings	(1) in table below					(2) in table below
OIS3/2 and OS1/0	All 0				Not all 0	—
CS5E	0		1		—	—
PB_2 DDR	0	1	1	—	—	—
NDER10	—	0	1	—	—	—
Pin function	PB_2 input	PB_2 output	TP_{10} output	\overline{CS}_5 output	$TMIO_2$ output	\overline{CS}_5 output*
	\overline{CS}_5 is output as \overline{RAS}_5 .					

Note: * \overline{CS}_5 is output as \overline{RAS}_5 .

DRAM interface settings	(1)				(2)	(1)	
DRAS2	0				1		
DRAS1	0		1		0		1
DRAS0	0	1	0	1	0	1	

Pin Pin Functions and Selection Method

PB₁/TP₉/
 TMIO₁/
 $\overline{\text{DREQ}}_0/\overline{\text{CS}}_6$

Bits OIS3/2 and OS1/0 in 8TCSR1, bits CCLR1 and CCLR0 in TCR1, bit CS6E in CSCR, bit NDER9 in NDERB, and bit PB₁DDR select the pin function as follows.

OIS3/2 and OS1/0	All 0			Not all 0	
CS6E	0			1	—
PB ₁ DDR	0	1	1	—	—
NDER9	—	0	1	—	—
Pin function	PB ₁ input	PB ₁ output	TP ₉ output	$\overline{\text{CS}}_6$ output	TMIO ₁ output
	TMIO ₁ input* ¹				
	$\overline{\text{DREQ}}_0$ input* ²				

- Notes:
1. TMIO₁ input when CCLR1 = CCLR0 = 1.
 2. When an external request is specified as a DMAC activation source, $\overline{\text{DREQ}}_0$ input regardless of bits OIS3/2 and OS1/0, bits CCLR1/0, bit CS6E, bit NDER9, and bit PB₁DDR.

PB₀/TP₈/
 TMO₀/ $\overline{\text{CS}}_7$

Bits OIS3/2 and OS1/0 in 8TCSR0, bit CS7E in CSCR, bit NDER8 in NDERB, and bit PB₀DDR select the pin function as follows.

OIS3/2 and OS1/0	All 0			Not all 0	
CS7E	0			1	—
PB ₀ DDR	0	1	1	—	—
NDER8	—	0	1	—	—
Pin function	PB ₀ input	PB ₀ output	TP ₈ output	$\overline{\text{CS}}_7$ output	TMO ₀ output

Table 8.24 Port B Pin Functions (Modes 6 and 7)**Pin Pin Functions and Selection Method**

PB₇/TP₁₅/RxD₂ Bit RE in SCR of SCI2, bit SMIF in SCMR, bit NDER15 in NDERB, and bit PB₇DDR select the pin function as follows.

SMIF	0				1
RE	0			1	—
PB ₇ DDR	0	1	1	—	—
NDER15	—	0	1	—	—
Pin function	PB ₇ input	PB ₇ output	TP ₁₅ output	RxD ₂ input	RxD ₂ input

PB₆/TP₁₄/TxD₂ Bit TE in SCR of SCI2, bit SMIF in SCMR, bit NDER14 in NDERB, and bit PB₆DDR select the pin function as follows.

SMIF	0				1
TE	0			1	—
PB ₆ DDR	0	1	1	—	—
NDER14	—	0	1	—	—
Pin function	PB ₆ input	PB ₆ output	TP ₁₄ output	TxD ₂ output	TxD ₂ output*

Note: * Functions as the TxD2 output pin, but there are two states: one in which the pin is driven, and another in which the pin is at high-impedance.

PB₅/TP₁₃/SCK₂ Bit C/ \bar{A} in SMR of SCI2, bits CKE0 and CKE1 in SCR, bit NDER13 in NDERB, and bit PB₅DDR select the pin function as follows.

CKE1	0				1
C/ \bar{A}	0			1	—
CKE0	0		1	—	—
PB ₅ DDR	0	1	1	—	—
NDER13	—	0	1	—	—
Pin function	PB ₅ input	PB ₅ output	TP ₁₃ output	SCK ₂ output	SCK ₂ output SCK ₂ input

PB₄/TP₁₂ Bit NDER12 in NDERB and bit PB₄DDR select the pin function as follows.

PB ₄ DDR	0	1	1
NDER12	—	0	1
Pin function	PB ₄ input	PB ₄ output	TP ₁₂ output

Pin Pin Functions and Selection Method

PB₃/TP₁₁/
TMIO₃/
 $\overline{\text{DREQ}}_1$

Bits OIS3/2 and OS1/0 in TCSR3, bits CCLR1 and CCLR0 in TCR3, bit NDER11 in NDERB, and bit PB₃DDR select the pin function as follows.

OIS3/2 and OS1/0	All 0			Not all 0
PB ₃ DDR	0	1	1	—
NDER11	—	0	1	—
Pin function	PB ₃ input	PB ₃ output	TP ₁₁ output	TMIO ₃ output
	TMIO ₃ input* ¹			
	$\overline{\text{DREQ}}_1$ input* ²			

- Notes:
1. TMIO₃ input when CCLR1 = CCLR0 = 1.
 2. When an external request is specified as a DMAC activation source, $\overline{\text{DREQ}}_1$ input regardless of bits OIS3/2 and OS1/0, bit NDER11, and bit PB₃DDR.

PB₂/TP₁₀/
TMO₂

Bits OIS3/2 and OS1/0 in TCSR2, bit NDER10 in NDERB, and bit PB₂DDR select the pin function as follows.

OIS3/2 and OS1/0	All 0			Not all 0
PB ₂ DDR	0	1	1	—
NDER10	—	0	1	—
Pin function	PB ₂ input	PB ₂ output	TP ₁₀ output	TMO ₂ output

PB₁/TP₉/
TMIO₁/
 $\overline{\text{DREQ}}_0$

Bits OIS3/2 and OS1/0 in TCSR1, bits CCLR1 and CCLR0 in TCR1, bit NDER9 in NDERB, and bit PB₁DDR select the pin function as follows.

OIS3/2 and OS1/0	All 0			Not all 0
PB ₁ DDR	0	1	1	—
NDER9	—	0	1	—
Pin function	PB ₁ input	PB ₁ output	TP ₉ output	TMIO ₁ output
	TMIO ₁ input* ¹			
	$\overline{\text{DREQ}}_0$ input* ²			

- Notes:
1. TMIO₁ input when CCLR1 = CCLR0 = 1.
 2. When an external request is specified as a DMAC activation source, $\overline{\text{DREQ}}_0$ input regardless of bits OIS3/2 and OS1/0, bit NDER9, and bit PB₁DDR.

PB₀/TP₈/
TMO₀

Bits OIS3/2 and OS1/0 in TCSR0, bit NDER8 in NDERB, and bit PB₀DDR select the pin function as follows.

OIS3/2 and OS1/0	All 0			Not all 0
PB ₀ DDR	0	1	1	—
NDER8	—	0	1	—
Pin function	PB ₀ input	PB ₀ output	TP ₈ output	TMO ₀ output

Section 9 16-Bit Timer

9.1 Overview

The H8/3068F has built-in 16-bit timer module with three 16-bit counter channels.

9.1.1 Features

16-bit timer features are listed below.

- Capability to process up to 6 pulse outputs or 6 pulse inputs
- Six general registers (GRs, two per channel) with independently-assignable output compare or input capture functions
- Selection of eight counter clock sources for each channel:
 - Internal clocks: ϕ , $\phi/2$, $\phi/4$, $\phi/8$
 - External clocks: TCLKA, TCLKB, TCLKC, TCLKD
- Five operating modes selectable in all channels:
 - Waveform output by compare match
 - Selection of 0 output, 1 output, or toggle output (only 0 or 1 output in channel 2)
 - Input capture function
 - Rising edge, falling edge, or both edges (selectable)
 - Counter clearing function
 - Counters can be cleared by compare match or input capture
 - Synchronization
 - Two or more timer counters (16TCNTs) can be preset simultaneously, or cleared simultaneously by compare match or input capture. Counter synchronization enables synchronous register input and output.
 - PWM mode
 - PWM output can be provided with an arbitrary duty cycle. With synchronization, up to three-phase PWM output is possible
- Phase counting mode selectable in channel 2
 - Two-phase encoder output can be counted automatically.
- High-speed access via internal 16-bit bus
 - The 16TCNTs and GRs can be accessed at high speed via a 16-bit bus.
- Any initial timer output value can be set

- Nine interrupt sources
Each channel has two compare match/input capture interrupts and an overflow interrupt. All interrupts can be requested independently.
- Output triggering of programmable timing pattern controller (TPC)
Compare match/input capture signals from channels 0 to 2 can be used as TPC output triggers.

Table 9.1 summarizes the 16-bit timer functions.

Table 9.1 16-bit timer Functions

Item		Channel 0	Channel 1	Channel 2
Clock sources		Internal clocks: ϕ , $\phi/2$, $\phi/4$, $\phi/8$ External clocks: TCLKA, TCLKB, TCLKC, TCLKD, selectable independently		
General registers (output compare/input capture registers)		GRA0, GRB0	GRA1, GRB1	GRA2, GRB2
Input/output pins		TIOCA ₀ , TIOCB ₀	TIOCA ₁ , TIOCB ₁	TIOCA ₂ , TIOCB ₂
Counter clearing function		GRA0/GRB0 compare match or input capture	GRA1/GRB1 compare match or input capture	GRA2/GRB2 compare match or input capture
Initial output value setting function		Available	Available	Available
Compare match output	0	Available	Available	Available
	1	Available	Available	Available
	Toggle	Available	Available	Not available
Input capture function		Available	Available	Available
Synchronization		Available	Available	Available
PWM mode		Available	Available	Available
Phase counting mode		Not available	Not available	Available
Interrupt sources		Three sources	Three sources	Three sources
		• Compare match/input capture A0	• Compare match/input capture A1	• Compare match/input capture A2
		• Compare match/input capture B0	• Compare match/input capture B1	• Compare match/input capture B2
		• Overflow	• Overflow	• Overflow

9.1.2 Block Diagrams

16-bit timer Block Diagram (Overall): Figure 9.1 is a block diagram of the 16-bit timer.

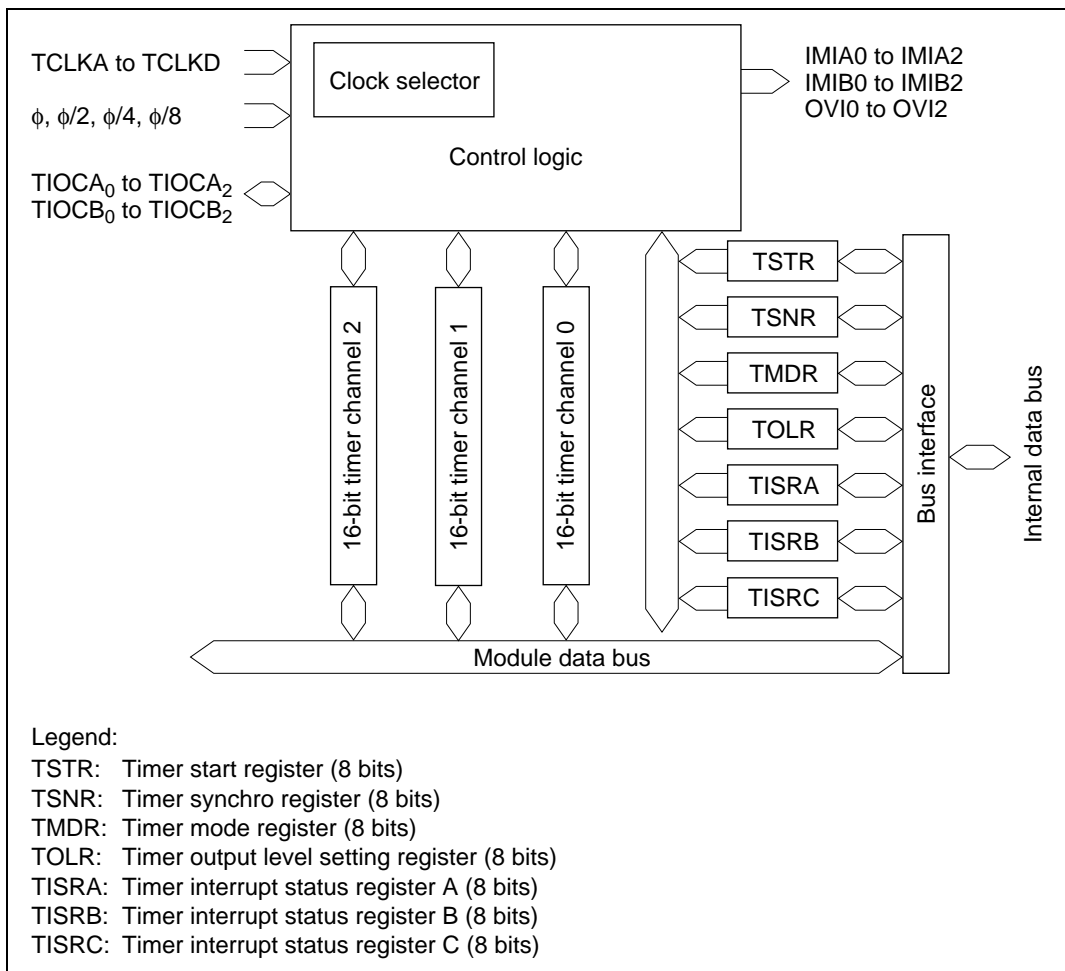

Figure 9.1 16-bit timer Block Diagram (Overall)

Block Diagram of Channels 0 and 1: 16-bit timer channels 0 and 1 are functionally identical. Both have the structure shown in figure 9.2.

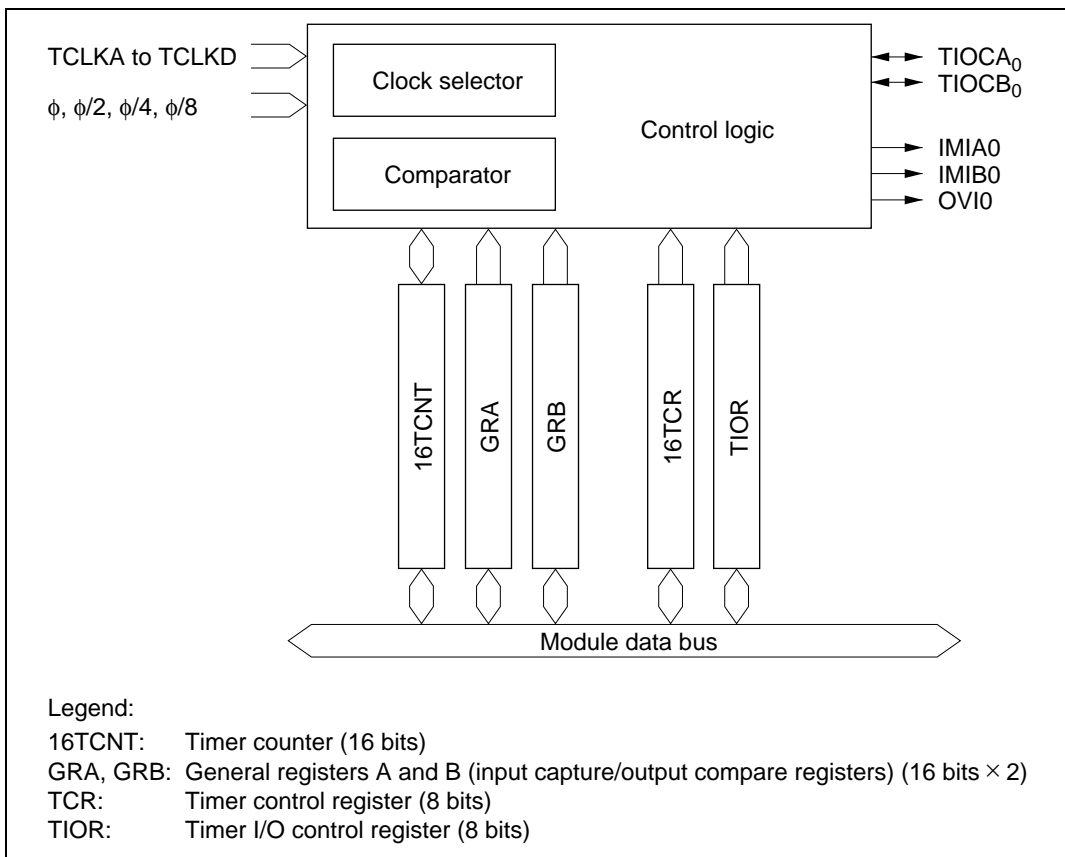

Figure 9.2 Block Diagram of Channels 0 and 1

Block Diagram of Channel 2: Figure 9.3 is a block diagram of channel 2

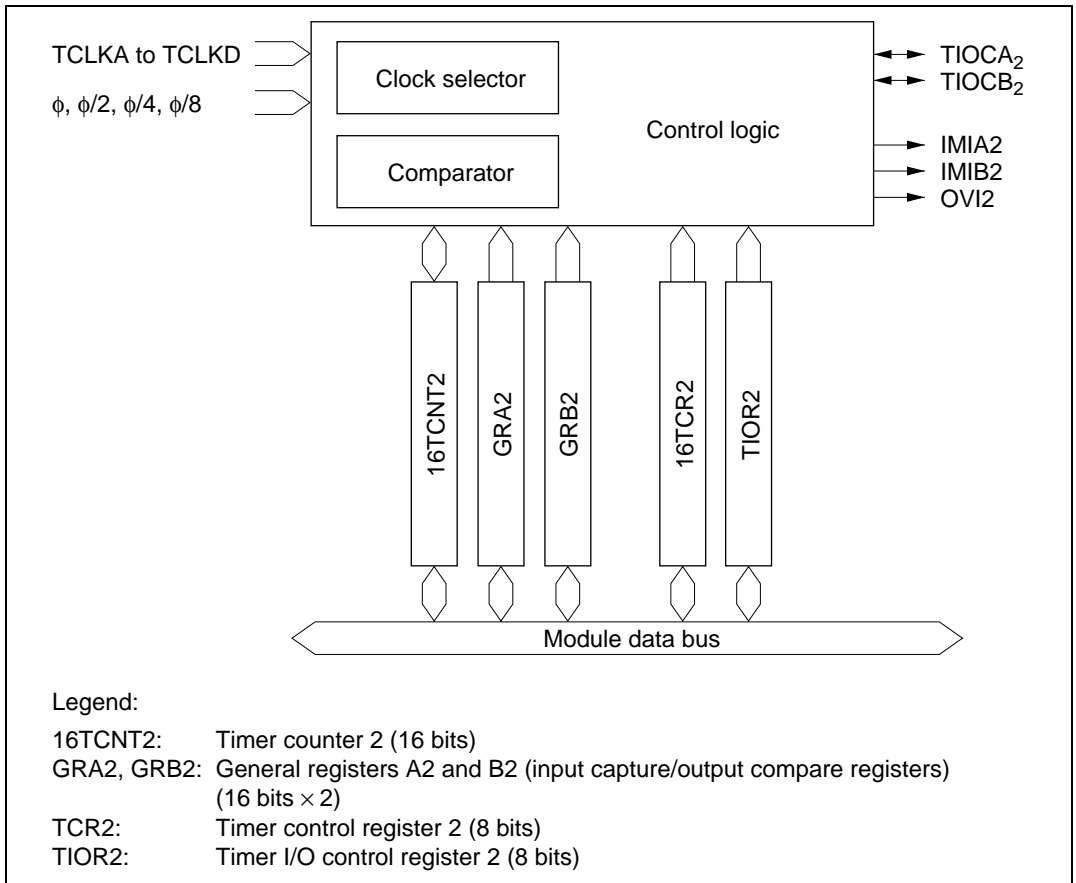

Figure 9.3 Block Diagram of Channel 2

9.1.3 Pin Configuration

Table 9.2 summarizes the 16-bit timer pins.

Table 9.2 16-bit timer Pins

Channel	Name	Abbreviation	Input/Output	Function
Common	Clock input A	TCLKA	Input	External clock A input pin (phase-A input pin in phase counting mode)
	Clock input B	TCLKB	Input	External clock B input pin (phase-B input pin in phase counting mode)
	Clock input C	TCLKC	Input	External clock C input pin
	Clock input D	TCLKD	Input	External clock D input pin
0	Input capture/output compare A0	TIOCA ₀	Input/output	GRA0 output compare or input capture pin PWM output pin in PWM mode
	Input capture/output compare B0	TIOCB ₀	Input/output	GRB0 output compare or input capture pin
1	Input capture/output compare A1	TIOCA ₁	Input/output	GRA1 output compare or input capture pin PWM output pin in PWM mode
	Input capture/output compare B1	TIOCB ₁	Input/output	GRB1 output compare or input capture pin
2	Input capture/output compare A2	TIOCA ₂	Input/output	GRA2 output compare or input capture pin PWM output pin in PWM mode
	Input capture/output compare B2	TIOCB ₂	Input/output	GRB2 output compare or input capture pin

9.1.4 Register Configuration

Table 9.3 summarizes the 16-bit timer registers.

Table 9.3 16-bit timer Registers

Channel	Address* ¹	Name	Abbreviation	R/W	Initial Value
Common	H'FFF60	Timer start register	TSTR	R/W	H'F8
	H'FFF61	Timer synchro register	TSNC	R/W	H'F8
	H'FFF62	Timer mode register	TMDR	R/W	H'98
	H'FFF63	Timer output level setting register	TOLR	W	H'C0
	H'FFF64	Timer interrupt status register A	TISRA	R/(W)* ²	H'88
	H'FFF65	Timer interrupt status register B	TISRB	R/(W)* ²	H'88
	H'FFF66	Timer interrupt status register C	TISRC	R/(W)* ²	H'88
0	H'FFF68	Timer control register 0	16TCR0	R/W	H'80
	H'FFF69	Timer I/O control register 0	TIOR0	R/W	H'88
	H'FFF6A	Timer counter 0H	16TCNT0H	R/W	H'00
	H'FFF6B	Timer counter 0L	16TCNT0L	R/W	H'00
	H'FFF6C	General register A0H	GRA0H	R/W	H'FF
	H'FFF6D	General register A0L	GRA0L	R/W	H'FF
	H'FFF6E	General register B0H	GRB0H	R/W	H'FF
	H'FFF6F	General register B0L	GRB0L	R/W	H'FF
1	H'FFF70	Timer control register 1	16TCR1	R/W	H'80
	H'FFF71	Timer I/O control register 1	TIOR1	R/W	H'88
	H'FFF72	Timer counter 1H	16TCNT1H	R/W	H'00
	H'FFF73	Timer counter 1L	16TCNT1L	R/W	H'00
	H'FFF74	General register A1H	GRA1H	R/W	H'FF
	H'FFF75	General register A1L	GRA1L	R/W	H'FF
	H'FFF76	General register B1H	GRB1H	R/W	H'FF
	H'FFF77	General register B1L	GRB1L	R/W	H'FF

Channel	Address* ¹	Name	Abbreviation	R/W	Initial Value
2	H'FFF78	Timer control register 2	16TCR2	R/W	H'80
	H'FFF79	Timer I/O control register 2	TIOR2	R/W	H'88
	H'FFF7A	Timer counter 2H	16TCNT2H	R/W	H'00
	H'FFF7B	Timer counter 2L	16TCNT2L	R/W	H'00
	H'FFF7C	General register A2H	GRA2H	R/W	H'FF
	H'FFF7D	General register A2L	GRA2L	R/W	H'FF
	H'FFF7E	General register B2H	GRB2H	R/W	H'FF
	H'FFF7F	General register B2L	GRB2L	R/W	H'FF

Notes: 1. The lower 20 bits of the address in advanced mode are indicated.
 2. Only 0 can be written in bits 3 to 0, to clear the flags.

9.2 Register Descriptions

9.2.1 Timer Start Register (TSTR)

TSTR is an 8-bit readable/writable register that starts and stops the timer counter (16TCNT) in channels 0 to 2.

Bit	7	6	5	4	3	2	1	0
	—	—	—	—	—	STR2	STR1	STR0
Initial value	1	1	1	1	1	0	0	0
Read/Write	—	—	—	—	—	R/W	R/W	R/W

Reserved bits
Counter start 2 to 0
These bits start and stop 16TCNT2 to 16TCNT0

TSTR is initialized to H'F8 by a reset and in standby mode.

Bits 7 to 3—Reserved: These bits cannot be modified and are always read as 1.

Bit 2—Counter Start 2 (STR2): Starts and stops timer counter 2 (16TCNT2).

Bit 2 STR2	Description
0	16TCNT2 is halted (Initial value)
1	16TCNT2 is counting

Bit 1—Counter Start 1 (STR1): Starts and stops timer counter 1 (16TCNT1).

Bit 1 STR1	Description
0	16TCNT1 is halted (Initial value)
1	16TCNT1 is counting

Bit 0—Counter Start 0 (STR0): Starts and stops timer counter 0 (16TCNT0).

Bit 0 STR0	Description
0	16TCNT0 is halted (Initial value)
1	16TCNT0 is counting

9.2.2 Timer Synchro Register (TSNC)

TSNC is an 8-bit readable/writable register that selects whether channels 0 to 2 operate independently or synchronously. Channels are synchronized by setting the corresponding bits to 1.

Bit	7	6	5	4	3	2	1	0
	—	—	—	—	—	SYNC2	SYNC1	SYNC0
Initial value	1	1	1	1	1	0	0	0
Read/Write	—	—	—	—	—	R/W	R/W	R/W

Reserved bits
Timer sync 2 to 0
These bits synchronize channels 2 to 0

TSNC is initialized to H'F8 by a reset and in standby mode.

Bits 7 to 3—Reserved: These bits cannot be modified and are always read as 1.

Bit 2—Timer Sync 2 (SYNC2): Selects whether channel 2 operates independently or synchronously.

Bit 2**SYNC2 Description**

0	Channel 2's timer counter (16TCNT2) operates independently 16TCNT2 is preset and cleared independently of other channels	(Initial value)
1	Channel 2 operates synchronously 16TCNT2 can be synchronously preset and cleared	

Bit 1—Timer Sync 1 (SYNC1): Selects whether channel 1 operates independently or synchronously.

Bit 1**SYNC1 Description**

0	Channel 1's timer counter (16TCNT1) operates independently 16TCNT1 is preset and cleared independently of other channels	(Initial value)
1	Channel 1 operates synchronously 16TCNT1 can be synchronously preset and cleared	

Bit 0—Timer Sync 0 (SYNC0): Selects whether channel 0 operates independently or synchronously.

Bit 0**SYNC0 Description**

0	Channel 0's timer counter (16TCNT0) operates independently 16TCNT0 is preset and cleared independently of other channels	(Initial value)
1	Channel 0 operates synchronously 16TCNT0 can be synchronously preset and cleared	

9.2.3 Timer Mode Register (TMDR)

TMDR is an 8-bit readable/writable register that selects PWM mode for channels 0 to 2. It also selects phase counting mode and the overflow flag (OVF) setting conditions for channel 2.

Bit	7	6	5	4	3	2	1	0
	—	MDF	FDIR	—	—	PWM2	PWM1	PWM0
Initial value	1	0	0	1	1	0	0	0
Read/Write	—	R/W	R/W	—	—	R/W	R/W	R/W

Reserved bit
 These bits select PWM mode for channels 2 to 0

Flag direction
 Selects the setting condition for the overflow flag (OVF) in TISRC

Phase counting mode flag
 Selects phase counting mode for channel 2

Reserved bit

TMDR is initialized to H'98 by a reset and in standby mode.

Bit 7—Reserved: This bit cannot be modified and is always read as 1.

Bit 6—Phase Counting Mode Flag (MDF): Selects whether channel 2 operates normally or in phase counting mode.

Bit 6

MDF	Description
0	Channel 2 operates normally (Initial value)
1	Channel 2 operates in phase counting mode

When MDF is set to 1 to select phase counting mode, 16TCNT2 operates as an up/down-counter and pins TCLKA and TCLKB become counter clock input pins. 16TCNT2 counts both rising and falling edges of TCLKA and TCLKB, and counts up or down as follows.

Counting Direction	Down-Counting				Up-Counting			
	↑	High	↓	Low	Low	↑	High	↓
TCLKA pin	↑	High	↓	Low	Low	↑	High	↓
TCLKB pin	Low	↑	High	↓	↑	High	↓	Low

In phase counting mode, external clock edge selection by bits CKEG1 and CKEG0 in 16TCR2 and counter clock selection by bits TPSC2 to TPSC0 are invalid, and the above phase counting mode operations take precedence.

The counter clearing condition selected by the CCLR1 and CCLR0 bits in 16TCR2 and the compare match/input capture settings and interrupt functions of TIOR2, TISRA, TISRB, TISRC remain effective in phase counting mode.

Bit 5—Flag Direction (FDIR): Designates the setting condition for the OVF flag in TISRC. The FDIR designation is valid in all modes in channel 2.

Bit 5 FDIR	Description
0	OVF is set to 1 in TISRC when 16TCNT2 overflows or underflows (Initial value)
1	OVF is set to 1 in TISRC when 16TCNT2 overflows

Bits 4 and 3—Reserved: These bits cannot be modified and are always read as 1.

Bit 2—PWM Mode 2 (PWM2): Selects whether channel 2 operates normally or in PWM mode.

Bit 2 PWM2	Description
0	Channel 2 operates normally (Initial value)
1	Channel 2 operates in PWM mode

When bit PWM2 is set to 1 to select PWM mode, pin TIOCA₂ becomes a PWM output pin. The output goes to 1 at compare match with GRA2, and to 0 at compare match with GRB2.

Bit 1—PWM Mode 1 (PWM1): Selects whether channel 1 operates normally or in PWM mode.

Bit 1 PWM1	Description
0	Channel 1 operates normally (Initial value)
1	Channel 1 operates in PWM mode

When bit PWM1 is set to 1 to select PWM mode, pin TIOCA₁ becomes a PWM output pin. The output goes to 1 at compare match with GRA1, and to 0 at compare match with GRB1.

Bit 0—PWM Mode 0 (PWM0): Selects whether channel 0 operates normally or in PWM mode.

Bit 0

PWM0	Description	
0	Channel 0 operates normally	(Initial value)
1	Channel 0 operates in PWM mode	

When bit PWM0 is set to 1 to select PWM mode, pin TIOCA₀ becomes a PWM output pin. The output goes to 1 at compare match with GRA0, and to 0 at compare match with GRB0.

9.2.4 Timer Interrupt Status Register A (TISRA)

TISRA is an 8-bit readable/writable register that indicates GRA compare match or input capture and enables or disables GRA compare match and input capture interrupt requests.

Bit	7	6	5	4	3	2	1	0
	—	IMIEA2	IMIEA1	IMIEA0	—	IMFA2	IMFA1	IMFA0
Initial value	1	0	0	0	1	0	0	0
Read/Write	—	R/W	R/W	R/W	—	R/(W)*	R/(W)*	R/(W)*

Reserved bit
Input capture/compare match interrupt enable A2 to A0
 These bits enable or disable interrupts by the IMFA flags

Reserved bit
Input capture/compare match flags A2 to A0
 Status flags indicating GRA compare match or input capture

Note: * Only 0 can be written, to clear the flag.

TISRA is initialized to H'88 by a reset and in standby mode.

Bit 7—Reserved: This bit cannot be modified and is always read as 1.

Bit 6—Input Capture/Compare Match Interrupt Enable A2 (IMIEA2): Enables or disables the interrupt requested by the IMFA2 when IMFA2 flag is set to 1.

Bit 6

IMIEA2	Description	
0	IMIA2 interrupt requested by IMFA2 flag is disabled	(Initial value)
1	IMIA2 interrupt requested by IMFA2 flag is enabled	

Bit 5—Input Capture/Compare Match Interrupt Enable A1 (IMIEA1): Enables or disables the interrupt requested by the IMFA1 flag when IMFA1 is set to 1.

Bit 5

IMIEA1	Description	
0	IMIA1 interrupt requested by IMFA1 flag is disabled	(Initial value)
1	IMIA1 interrupt requested by IMFA1 flag is enabled	

Bit 4—Input Capture/Compare Match Interrupt Enable A0 (IMIEA0): Enables or disables the interrupt requested by the IMFA0 flag when IMFA0 is set to 1.

Bit 4

IMIEA0	Description	
0	IMIA0 interrupt requested by IMFA0 flag is disabled	(Initial value)
1	IMIA0 interrupt requested by IMFA0 flag is enabled	

Bit 3—Reserved: This bit cannot be modified and is always read as 1.

Bit 2—Input Capture/Compare Match Flag A2 (IMFA2): This status flag indicates GRA2 compare match or input capture events.

Bit 2

IMFA2	Description	
0	[Clearing condition] Read IMFA2 flag when IMFA2 =1, then write 0 in IMFA2 flag	(Initial value)
1	[Setting conditions] <ul style="list-style-type: none"> 16TCNT2 = GRA2 when GRA2 functions as an output compare register 16TCNT2 value is transferred to GRA2 by an input capture signal when GRA2 functions as an input capture register 	

Bit 1—Input Capture/Compare Match Flag A1 (IMFA1): This status flag indicates GRA1 compare match or input capture events.

Bit 1 IMFA1	Description
0	[Clearing condition] (Initial value) Read IMFA1 flag when IMFA1 =1, then write 0 in IMFA1 flag
1	[Setting conditions] <ul style="list-style-type: none"> • 16TCNT1 = GRA1 when GRA1 functions as an output compare register • 16TCNT1 value is transferred to GRA1 by an input capture signal when GRA1 functions as an input capture register

Bit 0—Input Capture/Compare Match Flag A0 (IMFA0): This status flag indicates GRA0 compare match or input capture events.

Bit 0 IMFA0	Description
0	[Clearing condition] (Initial value) Read IMFA0 flag when IMFA0 =1, then write 0 in IMFA0 flag
1	[Setting conditions] <ul style="list-style-type: none"> • 16TCNT0 = GRA0 when GRA0 functions as an output compare register • 16TCNT0 value is transferred to GRA0 by an input capture signal when GRA0 functions as an input capture register

9.2.5 Timer Interrupt Status Register B (TISRB)

TISRB is an 8-bit readable/writable register that indicates GRB compare match or input capture and enables or disables GRB compare match and input capture interrupt requests.

Bit	7	6	5	4	3	2	1	0
	—	IMIEB2	IMIEB1	IMIEB0	—	IMFB2	IMFB1	IMFB0
Initial value	1	0	0	0	1	0	0	0
Read/Write	—	R/W	R/W	R/W	—	R/(W)*	R/(W)*	R/(W)*

Reserved bit
Input capture/compare match interrupt enable B2 to B0
 These bits enable or disable interrupts by the IMFB flags

Input capture/compare match flags B2 to B0
 Status flags indicating GRB compare match or input capture

Reserved bit

Note: * Only 0 can be written, to clear the flag.

TISRB is initialized to H'88 by a reset and in standby mode.

Bit 7—Reserved: This bit cannot be modified and is always read as 1.

Bit 6—Input Capture/Compare Match Interrupt Enable B2 (IMIEB2): Enables or disables the interrupt requested by the IMFB2 when IMFB2 flag is set to 1.

Bit 6

IMIEB2 Description

0	IMIEB2 interrupt requested by IMFB2 flag is disabled	(Initial value)
1	IMIEB2 interrupt requested by IMFB2 flag is enabled	

Bit 5—Input Capture/Compare Match Interrupt Enable B1 (IMIEB1): Enables or disables the interrupt requested by the IMFB1 when IMFB1 flag is set to 1.

Bit 5

IMIEB1	Description
0	IMIB1 interrupt requested by IMFB1 flag is disabled (Initial value)
1	IMIB1 interrupt requested by IMFB1 flag is enabled

Bit 4—Input Capture/Compare Match Interrupt Enable B0 (IMIEB0): Enables or disables the interrupt requested by the IMFB0 when IMFB0 flag is set to 1.

Bit 4

IMIEB0	Description
0	IMIB0 interrupt requested by IMFB0 flag is disabled (Initial value)
1	IMIB0 interrupt requested by IMFB0 flag is enabled

Bit 3—Reserved: This bit cannot be modified and is always read as 1.

Bit 2—Input Capture/Compare Match Flag B2 (IMFB2): This status flag indicates GRB2 compare match or input capture events.

Bit 2

IMFB2	Description
0	[Clearing condition] (Initial value) Read IMFB2 flag when IMFB2 =1, then write 0 in IMFB2 flag
1	[Setting conditions] <ul style="list-style-type: none"> 16TCNT2 = GRB2 when GRB2 functions as an output compare register 16TCNT2 value is transferred to GRB2 by an input capture signal when GRB2 functions as an input capture register

Bit 1—Input Capture/Compare Match Flag B1 (IMFB1): This status flag indicates GRB1 compare match or input capture events.

Bit 1 IMFB1	Description	
0	[Clearing condition] Read IMFB1 flag when IMFB1 =1, then write 0 in IMFB1 flag	(Initial value)
1	[Setting conditions] <ul style="list-style-type: none"> • 16TCNT1 = GRB1 when GRB1 functions as an output compare register • 16TCNT1 value is transferred to GRB1 by an input capture signal when GRB1 functions as an input capture register 	

Bit 0—Input Capture/Compare Match Flag B0 (IMFB0): This status flag indicates GRB0 compare match or input capture events.

Bit 0 IMFB0	Description	
0	[Clearing condition] Read IMFB0 flag when IMFB0 =1, then write 0 in IMFB0 flag	(Initial value)
1	[Setting conditions] <ul style="list-style-type: none"> • 16TCNT0 = GRB0 when GRB0 functions as an output compare register • 16TCNT0 value is transferred to GRB0 by an input capture signal when GRB0 functions as an input capture register 	

9.2.6 Timer Interrupt Status Register C (TISRC)

TISRC is an 8-bit readable/writable register that indicates 16TCNT overflow or underflow and enables or disables overflow interrupt requests.

Bit	7	6	5	4	3	2	1	0
	—	OVIE2	OVIE1	OVIE0	—	OVF2	OVF1	OVF0
Initial value	1	0	0	0	1	0	0	0
Read/Write	—	R/W	R/W	R/W	—	R/(W)*	R/(W)*	R/(W)*

Reserved bit
 Overflow interrupt enable 2 to 0
 These bits enable or disable interrupts by the OVF flags

Overflow flags 2 to 0
 Status flags indicating
 interrupts by OVF flags

Note: * Only 0 can be written, to clear the flag.

TISRC is initialized to H'88 by a reset and in standby mode.

Bit 7—Reserved: This bit cannot be modified and is always read as 1.

Bit 6—Overflow Interrupt Enable 2 (OVIE2): Enables or disables the interrupt requested by the OVF2 when OVF2 flag is set to 1.

Bit 6

OVIE2	Description
0	OVI2 interrupt requested by OVF2 flag is disabled (Initial value)
1	OVI2 interrupt requested by OVF2 flag is enabled

Bit 5—Overflow Interrupt Enable 1 (OVIE1): Enables or disables the interrupt requested by the OVF1 when OVF1 flag is set to 1.

Bit 5

OVIE1	Description
0	OVI1 interrupt requested by OVF1 flag is disabled (Initial value)
1	OVI1 interrupt requested by OVF1 flag is enabled

Bit 4—Overflow Interrupt Enable 0 (OVIE0): Enables or disables the interrupt requested by the OVF0 when OVF0 flag is set to 1.

Bit 4

OVIE0	Description	
0	OVI0 interrupt requested by OVF0 flag is disabled	(Initial value)
1	OVI0 interrupt requested by OVF0 flag is enabled	

Bit 3—Reserved: This bit cannot be modified and is always read as 1.

Bit 2—Overflow Flag 2 (OVF2): This status flag indicates 16TCNT2 overflow.

Bit 2

OVF2	Description	
0	[Clearing condition] Read OVF2 flag when OVF2 =1, then write 0 in OVF2 flag	(Initial value)
1	[Setting condition] 16TCNT2 overflowed from H'FFFF to H'0000, or underflowed from H'0000 to H'FFFF	

Note: 16TCNT underflow occurs when 16TCNT operates as an up/down-counter. Underflow occurs only when channel 2 operates in phase counting mode (MDF = 1 in TMDR).

Bit 1—Overflow Flag 1 (OVF1): This status flag indicates 16TCNT1 overflow.

Bit 1

OVF1	Description	
0	[Clearing condition] Read OVF1 flag when OVF1 =1, then write 0 in OVF1 flag	(Initial value)
1	[Setting condition] 16TCNT1 overflowed from H'FFFF to H'0000	

Bit 0—Overflow Flag 0 (OVF0): This status flag indicates 16TCNT0 overflow.

Bit 0

OVF0	Description	
0	[Clearing condition] Read OVF0 flag when OVF0 =1, then write 0 in OVF0 flag	(Initial value)
1	[Setting condition] 16TCNT0 overflowed from H'FFFF to H'0000	

9.2.7 Timer Counters (16TCNT)

16TCNT is a 16-bit counter. The 16-bit timer has three 16TCNTs, one for each channel.

Channel	Abbreviation	Function
0	16TCNT0	Up-counter
1	16TCNT1	
2	16TCNT2	Phase counting mode: up/down-counter Other modes: up-counter

Bit	15	14	13	12	11	10	9	8	7	6	5	4	3	2	1	0
	<input type="checkbox"/>	<input type="checkbox"/>	<input type="checkbox"/>	<input type="checkbox"/>	<input type="checkbox"/>	<input type="checkbox"/>	<input type="checkbox"/>	<input type="checkbox"/>	<input type="checkbox"/>	<input type="checkbox"/>	<input type="checkbox"/>	<input type="checkbox"/>	<input type="checkbox"/>	<input type="checkbox"/>	<input type="checkbox"/>	<input type="checkbox"/>
Initial value	0	0	0	0	0	0	0	0	0	0	0	0	0	0	0	0
Read/Write	R/W	R/W	R/W	R/W	R/W	R/W	R/W	R/W	R/W	R/W	R/W	R/W	R/W	R/W	R/W	R/W

Each 16TCNT is a 16-bit readable/writable register that counts pulse inputs from a clock source. The clock source is selected by bits TPSC2 to TPSC0 in 16TCR.

16TCNT0 and 16TCNT1 are up-counters. 16TCNT2 is an up/down-counter in phase counting mode and an up-counter in other modes.

16TCNT can be cleared to H'0000 by compare match with GRA or GRB or by input capture to GRA or GRB (counter clearing function).

When 16TCNT overflows (changes from H'FFFF to H'0000), the OVF flag is set to 1 in TISRC of the corresponding channel.

When 16TCNT underflows (changes from H'0000 to H'FFFF), the OVF flag is set to 1 in TISRC of the corresponding channel.

The 16TCNTs are linked to the CPU by an internal 16-bit bus and can be written or read by either word access or byte access.

Each 16TCNT is initialized to H'0000 by a reset and in standby mode.

9.2.8 General Registers (GRA, GRB)

The general registers are 16-bit registers. The 16-bit timer has 6 general registers, two in each channel.

Channel	Abbreviation	Function
0	GRA0, GRB0	Output compare/input capture register
1	GRA1, GRB1	
2	GRA2, GRB2	

Bit	15	14	13	12	11	10	9	8	7	6	5	4	3	2	1	0
Initial value	1	1	1	1	1	1	1	1	1	1	1	1	1	1	1	1
Read/Write	R/W	R/W	R/W	R/W	R/W	R/W	R/W	R/W	R/W	R/W	R/W	R/W	R/W	R/W	R/W	R/W

A general register is a 16-bit readable/writable register that can function as either an output compare register or an input capture register. The function is selected by settings in TIOR.

When a general register is used as an output compare register, its value is constantly compared with the 16TCNT value. When the two values match (compare match), the IMFA or IMFB flag is set to 1 in TISRA/TISRB. Compare match output can be selected in TIOR.

When a general register is used as an input capture register, an external input capture signal are detected and the current 16TCNT value is stored in the general register. The corresponding IMFA or IMFB flag in TISRA/TISRB is set to 1 at the same time. The edges of the input capture signal are selected in TIOR.

TIOR settings are ignored in PWM mode.

General registers are linked to the CPU by an internal 16-bit bus and can be written or read by either word access or byte access.

General registers are set as output compare registers (with no pin output) and initialized to H'FFFF by a reset and in standby mode.

9.2.9 Timer Control Registers (16TCR)

16TCR is an 8-bit register. The 16-bit timer has three 16TCRs, one in each channel.

Channel	Abbreviation	Function
0	16TCR0	16TCR controls the timer counter. The 16TCRs in all channels are functionally identical. When phase counting mode is selected in channel 2, the settings of bits CKEG1 and CKEG0 and TPSC2 to TPSC0 in 16TCR2 are ignored.
1	16TCR1	
2	16TCR2	

Bit	7	6	5	4	3	2	1	0
	—	CCLR1	CCLR0	CKEG1	CKEG0	TPSC2	TPSC1	TPSC0
Initial value	1	0	0	0	0	0	0	0
Read/Write	—	R/W	R/W	R/W	R/W	R/W	R/W	R/W

Reserved bit
Counter clear 1/0
 These bits select the counter clear source

Clock edge 1/0
 These bits select external clock edges

Timer prescaler 2 to 0
 These bits select the timer counter clock

Each 16TCR is an 8-bit readable/writable register that selects the timer counter clock source, selects the edge or edges of external clock sources, and selects how the counter is cleared.

16TCR is initialized to H'80 by a reset and in standby mode.

Bit 7—Reserved: This bit cannot be modified and is always read as 1.

Bits 6 and 5—Counter Clear 1 and 0 (CCLR1, CCLR0): These bits select how 16TCNT is cleared.

Bit 6 CCLR1	Bit 5 CCLR0	Description
0	0	16TCNT is not cleared (Initial value)
	1	16TCNT is cleared by GRA compare match or input capture* ¹
1	0	16TCNT is cleared by GRB compare match or input capture* ¹
	1	Synchronous clear: 16TCNT is cleared in synchronization with other synchronized timers* ²

Notes: 1. 16TCNT is cleared by compare match when the general register functions as an output compare register, and by input capture when the general register functions as an input capture register.

2. Selected in TSNC.

Bits 4 and 3—Clock Edge 1 and 0 (CKEG1, CKEG0): These bits select external clock input edges when an external clock source is used.

Bit 4 CKEG1	Bit 3 CKEG0	Description
0	0	Count rising edges (Initial value)
	1	Count falling edges
1	—	Count both edges

When channel 2 is set to phase counting mode, bits CKEG1 and CKEG0 in 16TCR2 are ignored. Phase counting takes precedence.

Bits 2 to 0—Timer Prescaler 2 to 0 (TPSC2 to TPSC0): These bits select the counter clock source.

Bit 2 TPSC2	Bit 1 TPSC1	Bit 0 TPSC0	Function
0	0	0	Internal clock: ϕ (Initial value)
		1	Internal clock: $\phi/2$
	1	0	Internal clock: $\phi/4$
		1	Internal clock: $\phi/8$
1	0	0	External clock A: TCLKA input
		1	External clock B: TCLKB input
	1	0	External clock C: TCLKC input
		1	External clock D: TCLKD input

When bit TPSC2 is cleared to 0 an internal clock source is selected, and the timer counts only falling edges. When bit TPSC2 is set to 1 an external clock source is selected, and the timer counts the edges selected by bits CKEG1 and CKEG0.

When channel 2 is set to phase counting mode (MDF = 1 in TMDR), the settings of bits TPSC2 to TPSC0 in 16TCR2 are ignored. Phase counting takes precedence.

9.2.10 Timer I/O Control Register (TIOR)

TIOR is an 8-bit register. The 16-bit timer has three TIORs, one in each channel.

Channel	Abbreviation	Function
0	TIOR0	TIOR controls the general registers. Some functions differ in PWM mode.
1	TIOR1	
2	TIOR2	

Bit	7	6	5	4	3	2	1	0
	—	IOB2	IOB1	IOB0	—	IOA2	IOA1	IOA0
Initial value	1	0	0	0	1	0	0	0
Read/Write	—	R/W	R/W	R/W	—	R/W	R/W	R/W

Reserved bit
 I/O control B2 to B0
 These bits select GRB functions

Reserved bit
 I/O control A2 to A0
 These bits select GRA functions

Each TIOR is an 8-bit readable/writable register that selects the output compare or input capture function for GRA and GRB, and specifies the functions of the TIORA and TIORB pins. If the output compare function is selected, TIOR also selects the type of output. If input capture is selected, TIOR also selects the edges of the input capture signal.

TIOR is initialized to H'88 by a reset and in standby mode.

Bit 7—Reserved: This bit cannot be modified and is always read as 1.

Bits 6 to 4—I/O Control B2 to B0 (IOB2 to IOB0): These bits select the GRB function.

Bit 6 IOB2	Bit 5 IOB1	Bit 4 IOB0	Function	
0	0	0	GRB is an output compare register	No output at compare match (Initial value)
		1		0 output at GRB compare match* ¹
	1	0		1 output at GRB compare match* ¹
		1		Output toggles at GRB compare match (1 output in channel 2)* ¹ * ²
1	0	0	GRB is an input compare register	GRB captures rising edge of input
		1		GRB captures falling edge of input
	1	0		GRB captures both edges of input
		1		

- Notes: 1. After a reset, the output conforms to the TOLR setting until the first compare match.
2. Channel 2 output cannot be toggled by compare match. When this setting is made, 1 output is selected automatically.

Bit 3—Reserved: This bit cannot be modified and is always read as 1.

Bits 2 to 0—I/O Control A2 to A0 (IOA2 to IOA0): These bits select the GRA function.

Bit 2 IOA2	Bit 1 IOA1	Bit 0 IOA0	Function	
0	0	0	GRA is an output compare register	No output at compare match (Initial value)
		1		0 output at GRA compare match* ¹
	1	0		1 output at GRA compare match* ¹
		1		Output toggles at GRA compare match (1 output in channel 2)* ¹ * ²
1	0	0	GRA is an input compare register	GRA captures rising edge of input
		1		GRA captures falling edge of input
	1	0		GRA captures both edges of input
		1		

- Notes: 1. After a reset, the output conforms to the TOLR setting until the first compare match.
2. Channel 2 output cannot be toggled by compare match. When this setting is made, 1 output is selected automatically.

9.2.11 Timer Output Level Setting Register C (TOLR)

TOLR is an 8-bit write-only register that selects the timer output level for channels 0 to 2.

Bit	7	6	5	4	3	2	1	0
	—	—	TOB2	TOA2	TOB1	TOA1	TOB0	TOA0
Initial value	1	1	0	0	0	0	0	0
Read/Write	—	—	W	W	W	W	W	W

Reserved bits

Output level setting A2 to A0, B2 to B0
 These bits set the levels of the timer outputs (TIOCA₂ to TIOCA₀, and TIOCB₂ to TIOCB₀)

A TOLR setting can only be made when the corresponding bit in TSTR is 0.

TOLR is a write-only register, and cannot be read. If it is read, all bits will return a value of 1.

TOLR is initialized to H'00 by a reset and in standby mode.

Bits 7 and 6—Reserved: These bits cannot be modified.

Bit 5—Output Level Setting B2 (TOB2): Sets the value of timer output TIOCB₂.

Bit 5

TOB2	Description
0	TIOCB ₂ is 0 (Initial value)
1	TIOCB ₂ is 1

Bit 4—Output Level Setting A2 (TOA2): Sets the value of timer output TIOCA₂.

Bit 4

TOA2	Description
0	TIOCA ₂ is 0 (Initial value)
1	TIOCA ₂ is 1

Bit 3—Output Level Setting B1 (TOB1): Sets the value of timer output TIOCB₁.

Bit 3 TOB1	Description	
0	TIOCB ₁ is 0	(Initial value)
1	TIOCB ₁ is 1	

Bit 2—Output Level Setting A1 (TOA1): Sets the value of timer output TIOCA₁.

Bit 2 TOA1	Description	
0	TIOCA ₁ is 0	(Initial value)
1	TIOCA ₁ is 1	

Bit 1—Output Level Setting B0 (TOB0): Sets the value of timer output TIOCB₀.

Bit 0 TOB0	Description	
0	TIOCB ₀ is 0	(Initial value)
1	TIOCB ₀ is 1	

Bit 0—Output Level Setting A0 (TOA0): Sets the value of timer output TIOCA₀.

Bit 0 TOA0	Description	
0	TIOCA ₀ is 0	(Initial value)
1	TIOCA ₀ is 1	

9.3 CPU Interface

9.3.1 16-Bit Accessible Registers

The timer counters (16TCNTs), general registers A and B (GRAs and GRBs) are 16-bit registers, and are linked to the CPU by an internal 16-bit data bus. These registers can be written or read a word at a time, or a byte at a time.

Figures 9.4 and 9.5 show examples of word read/write access to a timer counter (16TCNT). Figures 9.6 to 9.9 show examples of byte read/write access to 16TCNTH and 16TCNTL.

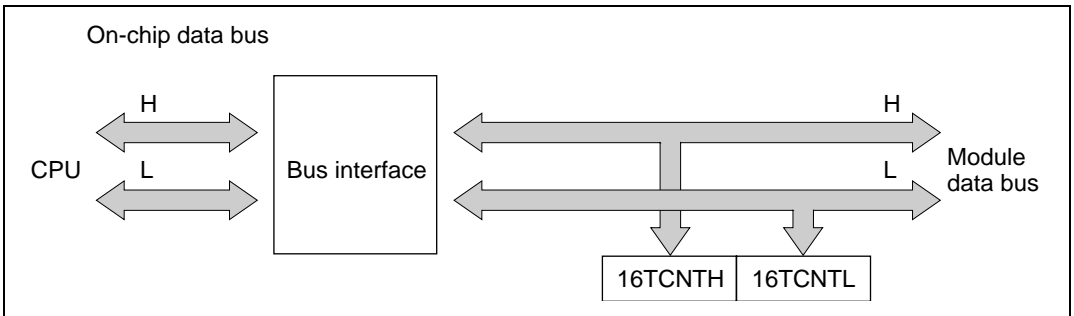

Figure 9.4 16TCNT Access Operation [CPU → 16TCNT (Word)]

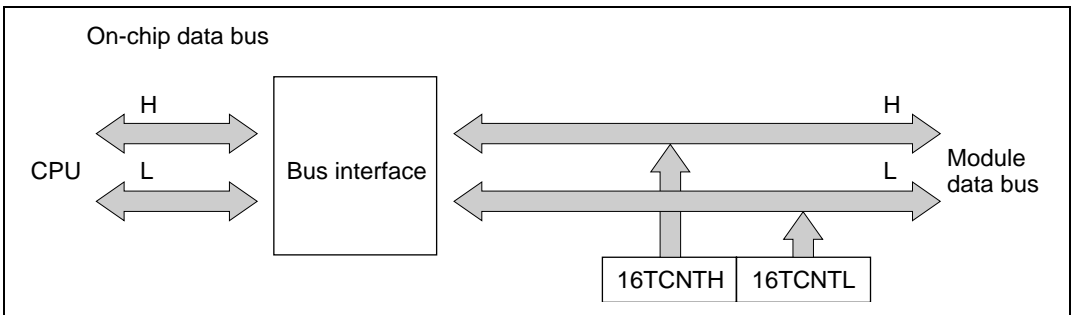

Figure 9.5 Access to Timer Counter (CPU Reads 16TCNT, Word)

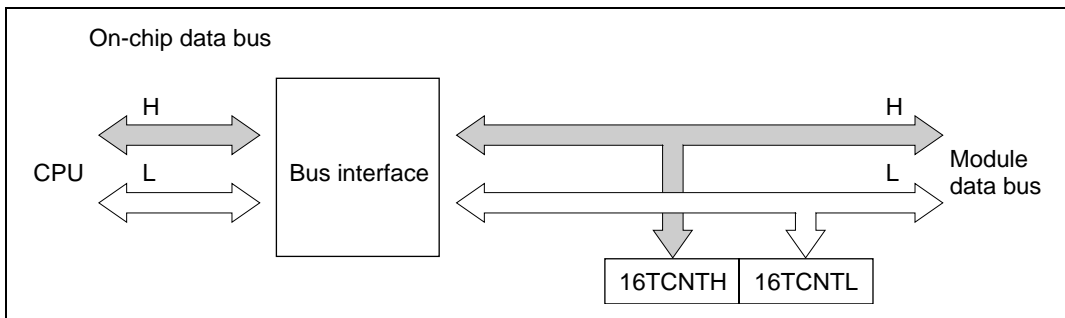

Figure 9.6 Access to Timer Counter H (CPU Writes to 16TCNTH, Upper Byte)

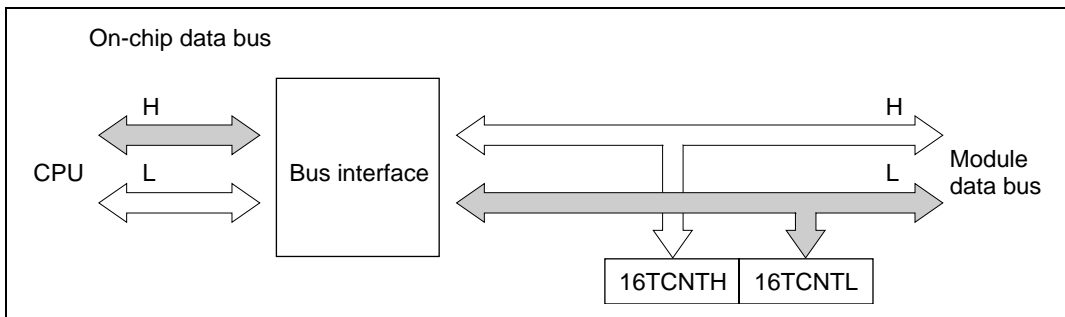

Figure 9.7 Access to Timer Counter L (CPU Writes to 16TCNTL, Lower Byte)

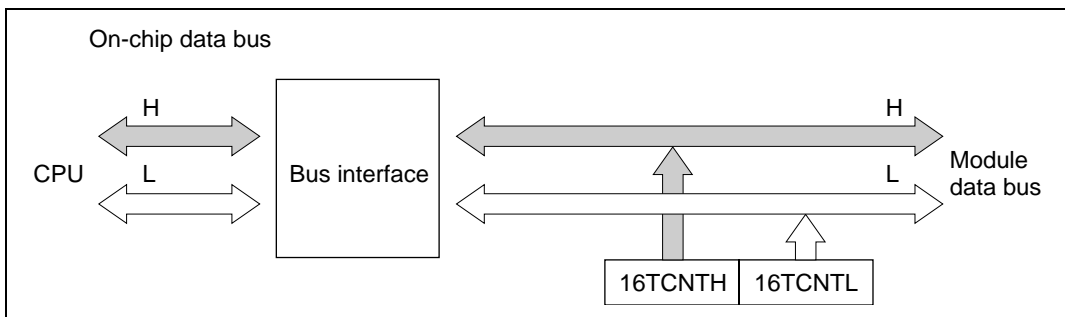

Figure 9.8 Access to Timer Counter H (CPU Reads 16TCNTH, Upper Byte)

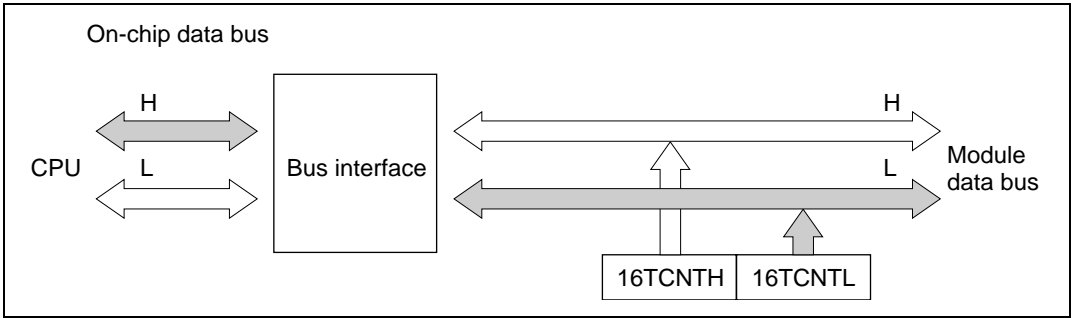

Figure 9.9 Access to Timer Counter L (CPU Reads 16TCNTL, Lower Byte)

9.3.2 8-Bit Accessible Registers

The registers other than the timer counters and general registers are 8-bit registers. These registers are linked to the CPU by an internal 8-bit data bus.

Figures 9.10 and 9.11 show examples of byte read and write access to a 16TCR.

If a word-size data transfer instruction is executed, two byte transfers are performed.

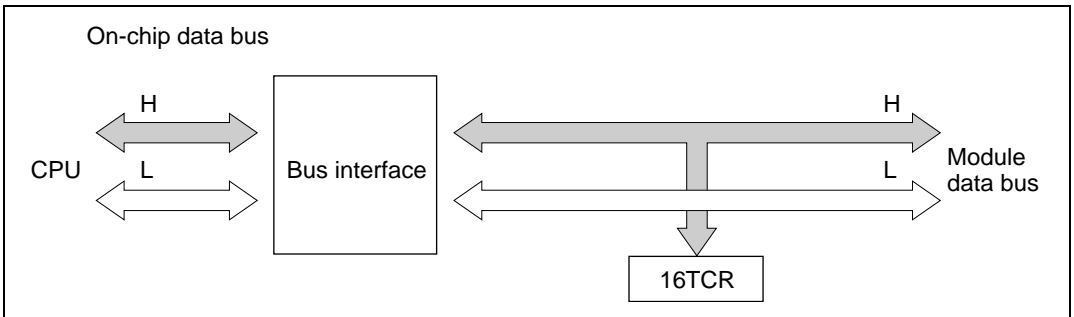

Figure 9.10 16TCR Access (CPU Writes to 16TCR)

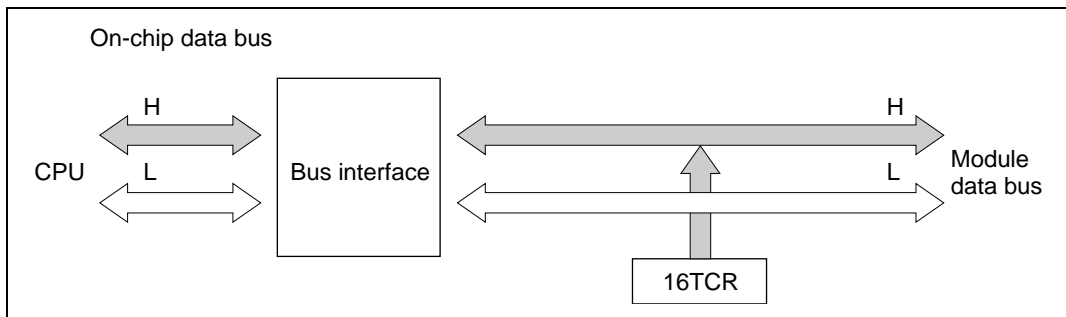

Figure 9.11 16TCR Access (CPU Reads 16TCR)

9.4 Operation

9.4.1 Overview

A summary of operations in the various modes is given below.

Normal Operation: Each channel has a timer counter and general registers. The timer counter counts up, and can operate as a free-running counter, periodic counter, or external event counter. GRA and GRB can be used for input capture or output compare.

Synchronous Operation: The timer counters in designated channels are preset synchronously. Data written to the timer counter in any one of these channels is simultaneously written to the timer counters in the other channels as well. The timer counters can also be cleared synchronously if so designated by the CCLR1 and CCLR0 bits in the TCRs.

PWM Mode: A PWM waveform is output from the TIOCA pin. The output goes to 1 at compare match A and to 0 at compare match B. The duty cycle can be varied from 0% to 100% depending on the settings of GRA and GRB. When a channel is set to PWM mode, its GRA and GRB automatically become output compare registers.

Phase Counting Mode: The phase relationship between two clock signals input at TCLKA and TCLKB is detected and 16TCNT2 counts up or down accordingly. When phase counting mode is selected TCLKA and TCLKB become clock input pins and 16TCNT2 operates as an up/down-counter.

9.4.2 Basic Functions

Counter Operation: When one of bits STR0 to STR2 is set to 1 in the timer start register (TSTR), the timer counter (16TCNT) in the corresponding channel starts counting. The counting can be free-running or periodic.

- Sample setup procedure for counter

Figure 9.12 shows a sample procedure for setting up a counter.

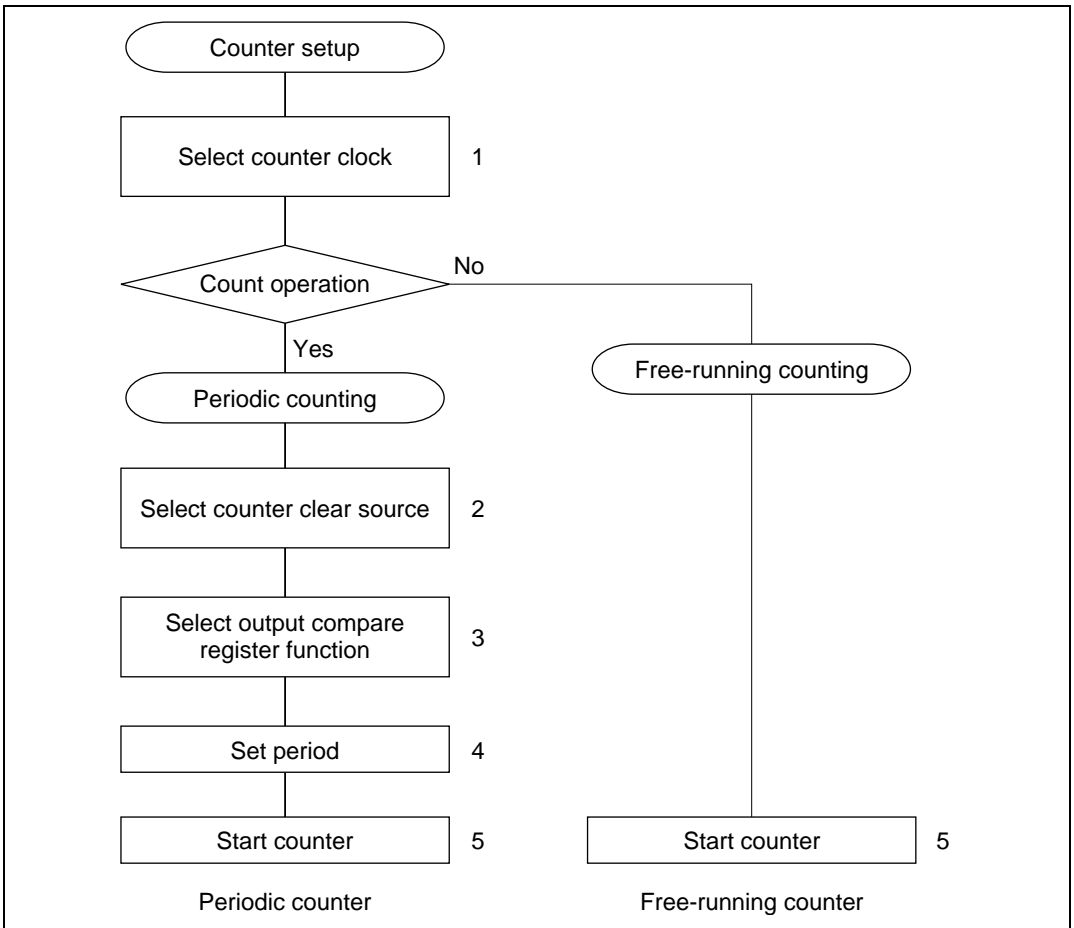

Figure 9.12 Counter Setup Procedure (Example)

1. Set bits TPSC2 to TPSC0 in 16TCR to select the counter clock source. If an external clock source is selected, set bits CKEG1 and CKEG0 in 16TCR to select the desired edge(s) of the external clock signal.
 2. For periodic counting, set CCLR1 and CCLR0 in 16TCR to have 16TCNT cleared at GRA compare match or GRB compare match.
 3. Set TIOR to select the output compare function of GRA or GRB, whichever was selected in step 2.
 4. Write the count period in GRA or GRB, whichever was selected in step 2.
 5. Set the STR bit to 1 in TSTR to start the timer counter.
- Free-running and periodic counter operation

A reset leaves the counters (16TCNTs) in 16-bit timer channels 0 to 2 all set as free-running counters. A free-running counter starts counting up when the corresponding bit in TSTR is set to 1. When the count overflows from H'FFFF to H'0000, the OVF flag is set to 1 in TISRC. After the overflow, the counter continues counting up from H'0000. Figure 9.13 illustrates free-running counting.

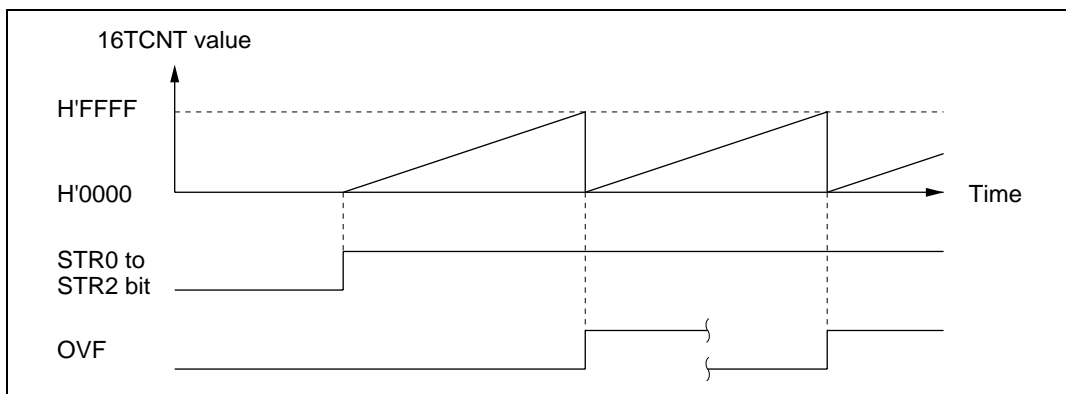

Figure 9.13 Free-Running Counter Operation

When a channel is set to have its counter cleared by compare match, in that channel 16TCNT operates as a periodic counter. Select the output compare function of GRA or GRB, set bit CCLR1 or CCLR0 in 16TCR to have the counter cleared by compare match, and set the count period in GRA or GRB. After these settings, the counter starts counting up as a periodic counter when the corresponding bit is set to 1 in TSTR. When the count matches GRA or GRB, the IMFA or IMFB flag is set to 1 in TISRA/TISRB and the counter is cleared to H'0000. If the corresponding IMIEA or IMIEB bit is set to 1 in TISRA/TISRB, a CPU interrupt is requested at this time. After the compare match, 16TCNT continues counting up from H'0000. Figure 9.14 illustrates periodic counting.

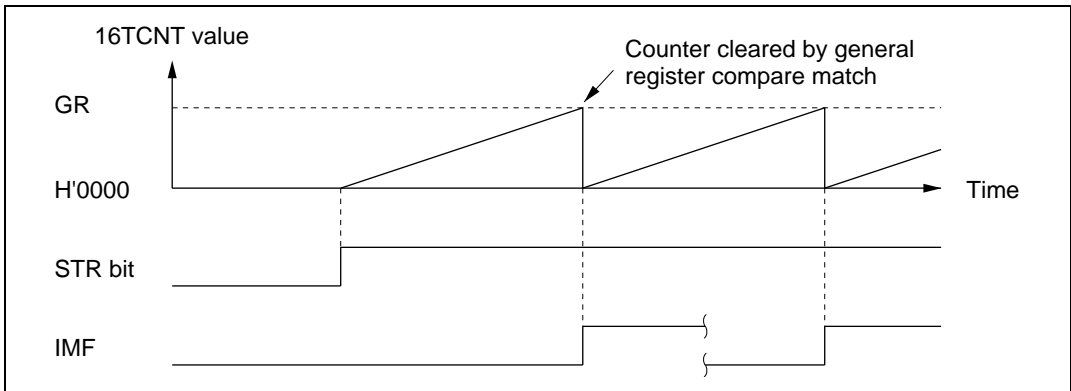

Figure 9.14 Periodic Counter Operation

- 16TCNT count timing

- Internal clock source

Bits TPSC2 to TPSC0 in 16TCR select the system clock (ϕ) or one of three internal clock sources obtained by prescaling the system clock ($\phi/2$, $\phi/4$, $\phi/8$).

Figure 9.15 shows the timing.

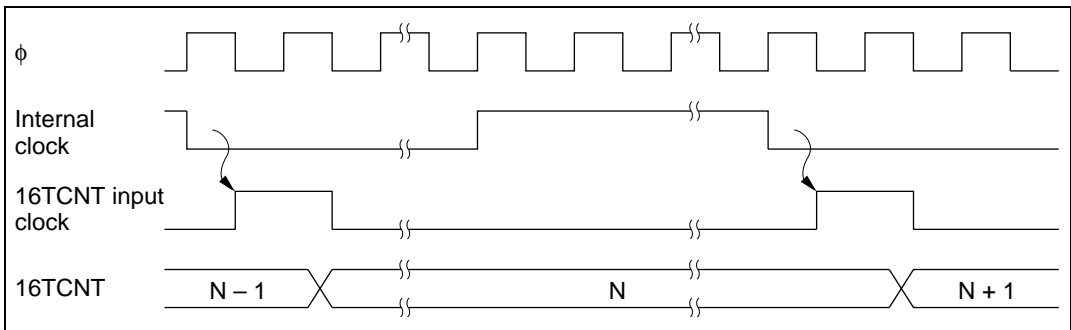

Figure 9.15 Count Timing for Internal Clock Sources

- External clock source

The external clock pin (TCLKA to TCLKD) can be selected by bits TPSC2 to TPSC0 in 16TCR, and the detected edge by bits CKEG1 and CKEG0. The rising edge, falling edge, or both edges can be selected.

The pulse width of the external clock signal must be at least 1.5 system clocks when a single edge is selected, and at least 2.5 system clocks when both edges are selected.

Shorter pulses will not be counted correctly.

Figure 9.16 shows the timing when both edges are detected.

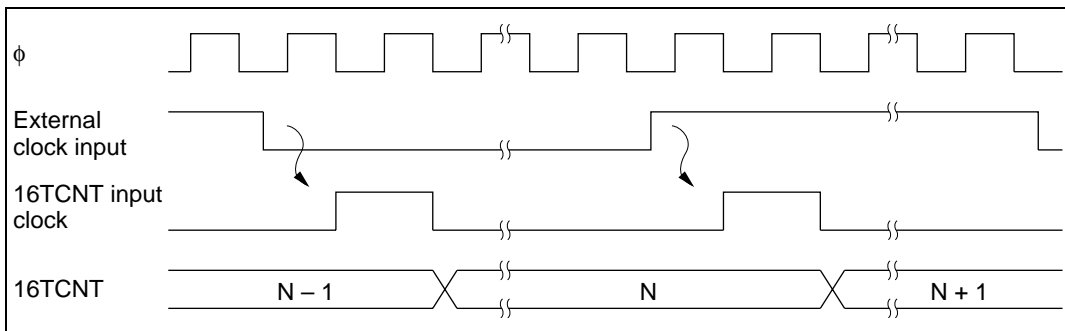

Figure 9.16 Count Timing for External Clock Sources (when Both Edges are Detected)

Waveform Output by Compare Match: In 16-bit timer channels 0, 1 compare match A or B can cause the output at the TIOCA or TIOCB pin to go to 0, go to 1, or toggle. In channel 2 the output can only go to 0 or go to 1.

- Sample setup procedure for waveform output by compare match

Figure 9.17 shows an example of the setup procedure for waveform output by compare match.

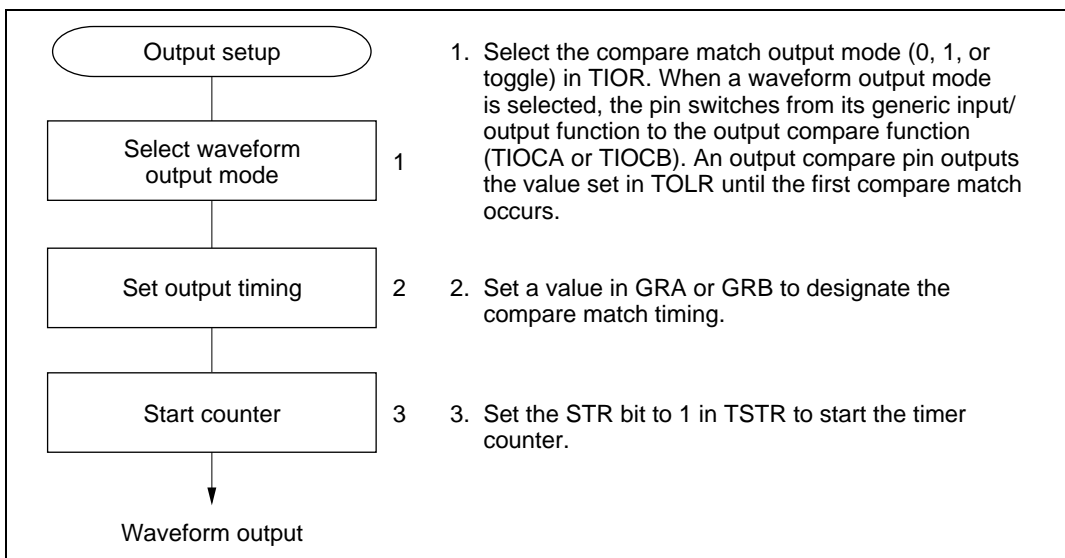

Figure 9.17 Setup Procedure for Waveform Output by Compare Match (Example)

- Examples of waveform output

Figure 9.18 shows examples of 0 and 1 output. 16TCNT operates as a free-running counter, 0 output is selected for compare match A, and 1 output is selected for compare match B. When the pin is already at the selected output level, the pin level does not change.

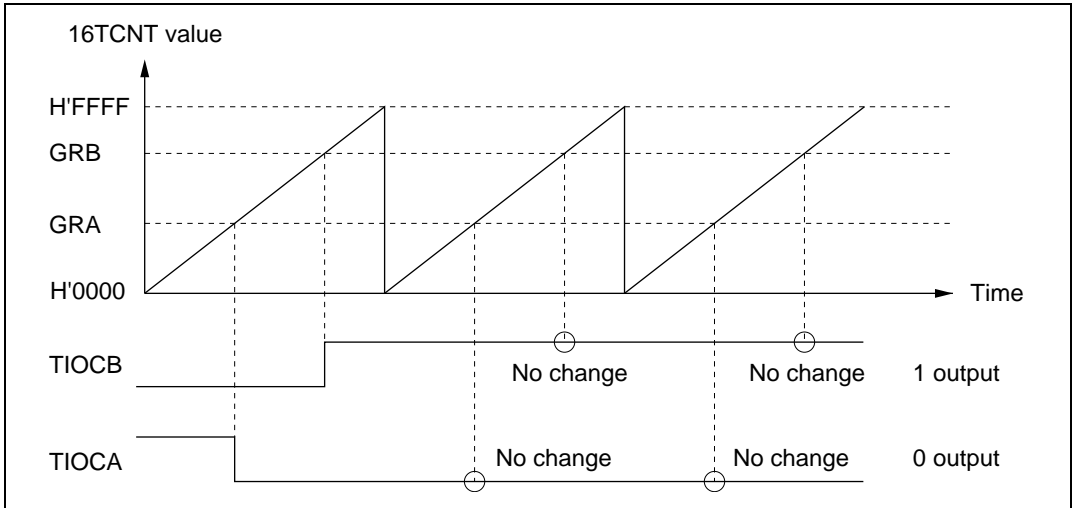

Figure 9.18 0 and 1 Output (TOA = 1, TOB = 0)

Figure 9.19 shows examples of toggle output. 16TCNT operates as a periodic counter, cleared by compare match B. Toggle output is selected for both compare match A and B.

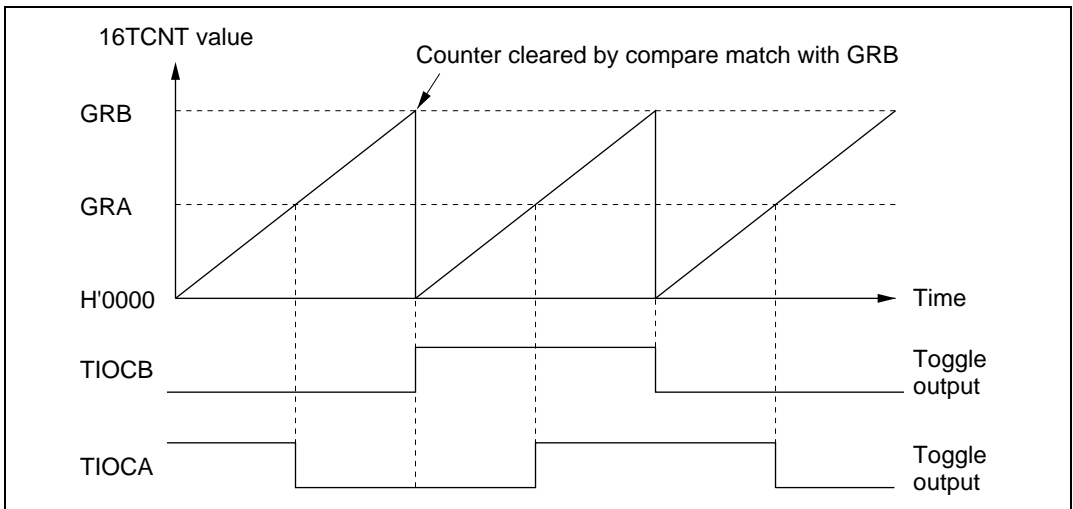

Figure 9.19 Toggle Output (TOA = 1, TOB = 0)

- Output compare output timing

The compare match signal is generated in the last state in which 16TCNT and the general register match (when 16TCNT changes from the matching value to the next value). When the compare match signal is generated, the output value selected in TIOR is output at the output compare pin (TIOCA or TIOCB). When 16TCNT matches a general register, the compare match signal is not generated until the next counter clock pulse.

Figure 9.20 shows the output compare timing.

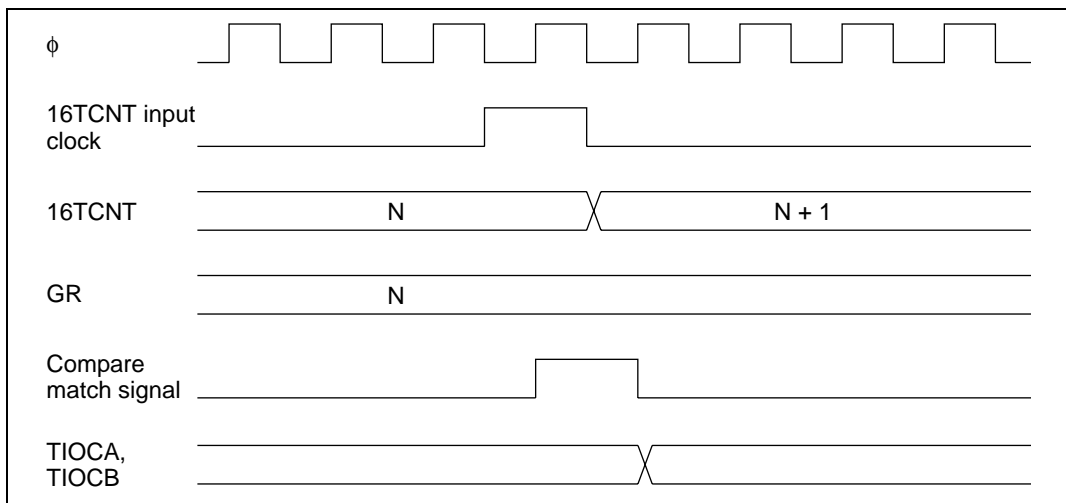

Figure 9.20 Output Compare Output Timing

Input Capture Function: The 16TCNT value can be transferred to a general register when an input edge is detected at an input capture input/output compare pin (TIOCA or TIOCB). Rising-edge, falling-edge, or both-edge detection can be selected. The input capture function can be used to measure pulse width or period.

- Sample setup procedure for input capture

Figure 9.21 shows a sample procedure for setting up input capture.

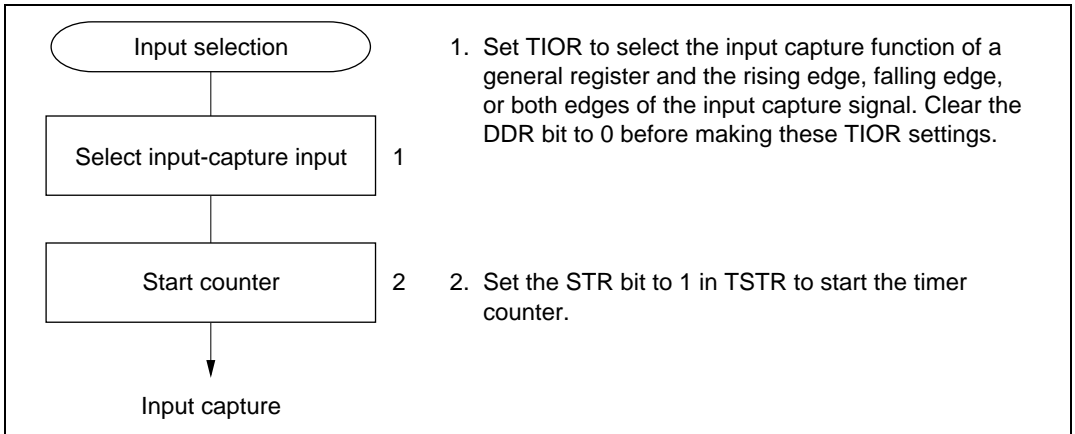

Figure 9.21 Setup Procedure for Input Capture (Example)

- Examples of input capture

Figure 9.22 illustrates input capture when the falling edge of TIOCB and both edges of TIOCA are selected as capture edges. 16TCNT is cleared by input capture into GRB.

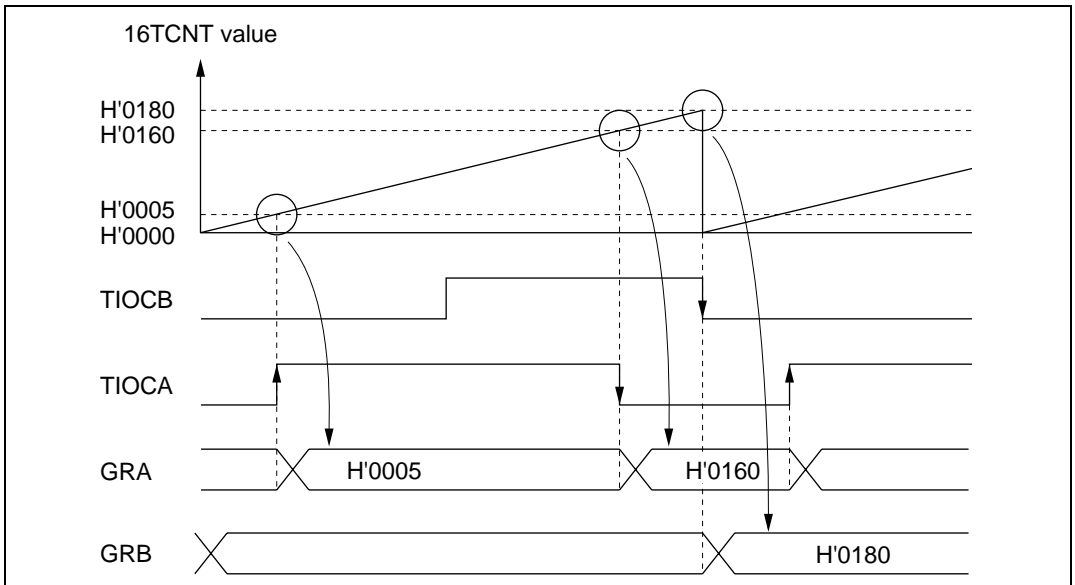

Figure 9.22 Input Capture (Example)

- Input capture signal timing

Input capture on the rising edge, falling edge, or both edges can be selected by settings in TIOR. Figure 9.23 shows the timing when the rising edge is selected. The pulse width of the input capture signal must be at least 1.5 system clocks for single-edge capture, and 2.5 system clocks for capture of both edges.

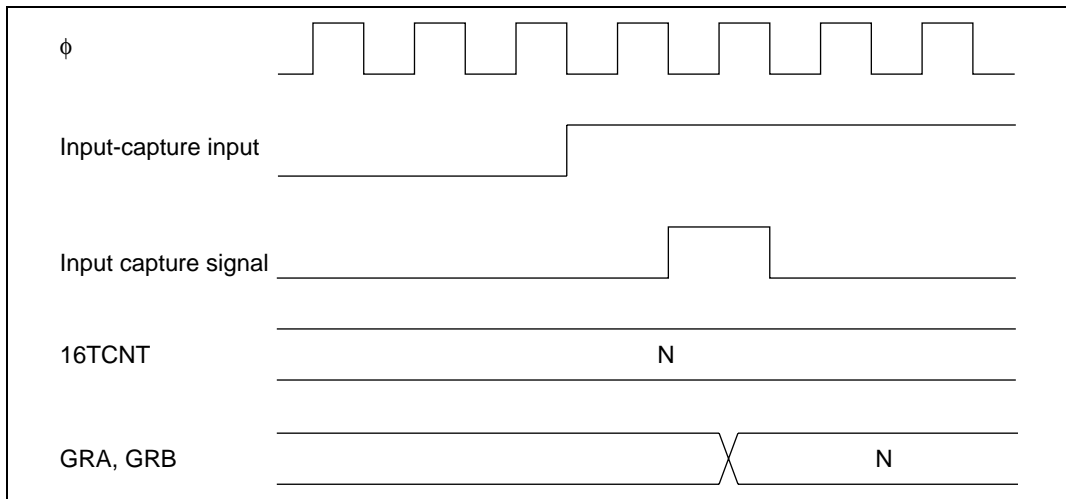

Figure 9.23 Input Capture Signal Timing

9.4.3 Synchronization

The synchronization function enables two or more timer counters to be synchronized by writing the same data to them simultaneously (synchronous preset). With appropriate 16TCR settings, two or more timer counters can also be cleared simultaneously (synchronous clear). Synchronization enables additional general registers to be associated with a single time base. Synchronization can be selected for all channels (0 to 2).

Sample Setup Procedure for Synchronization: Figure 9.24 shows a sample procedure for setting up synchronization.

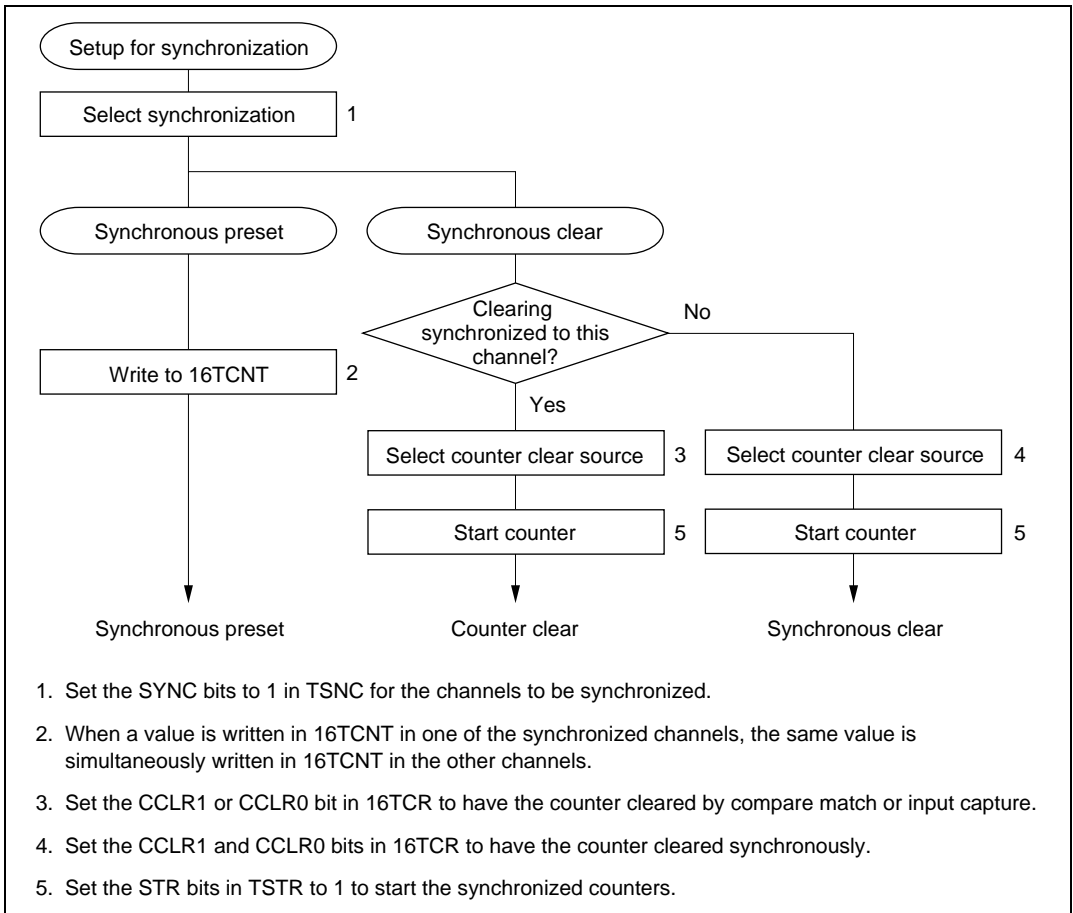

Figure 9.24 Setup Procedure for Synchronization (Example)

Example of Synchronization: Figure 9.25 shows an example of synchronization. Channels 0, 1, and 2 are synchronized, and are set to operate in PWM mode. Channel 0 is set for counter clearing by compare match with GRB0. Channels 1 and 2 are set for synchronous counter clearing. The timer counters in channels 0, 1, and 2 are synchronously preset, and are synchronously cleared by compare match with GRB0. A three-phase PWM waveform is output from pins TIOCA₀, TIOCA₁, and TIOCA₂. For further information on PWM mode, see section 9.4.4, PWM Mode.

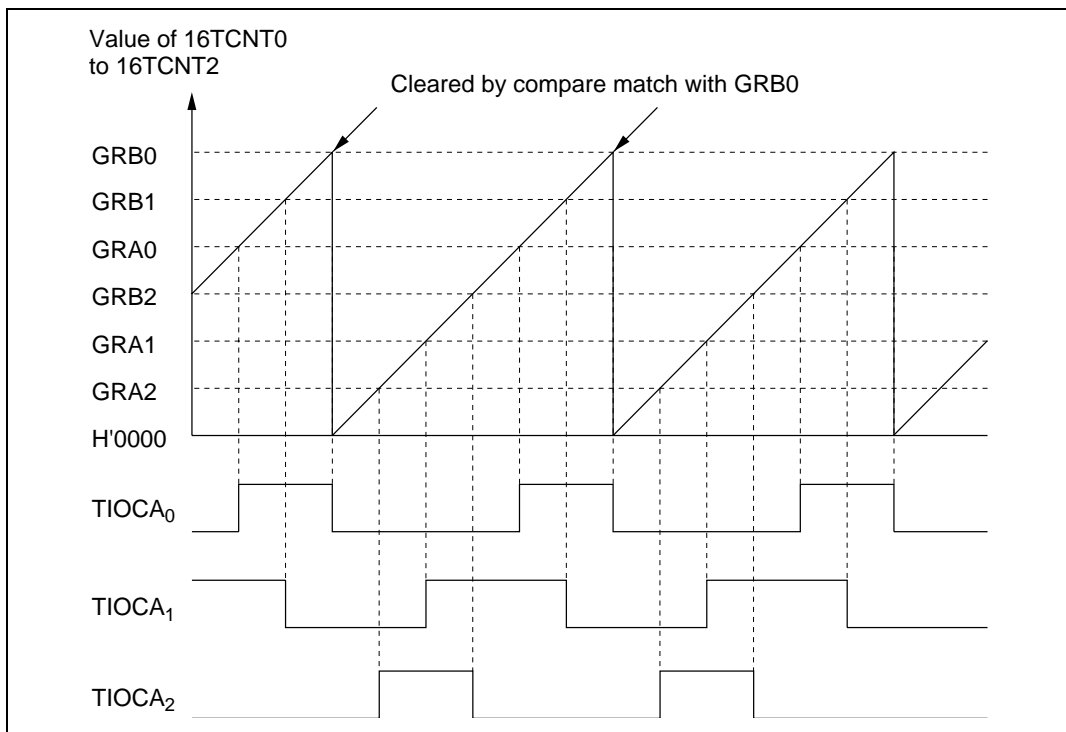

Figure 9.25 Synchronization (Example)

9.4.4 PWM Mode

In PWM mode GRA and GRB are paired and a PWM waveform is output from the TIOCA pin. GRA specifies the time at which the PWM output changes to 1. GRB specifies the time at which the PWM output changes to 0. If either GRA or GRB compare match is selected as the counter clear source, a PWM waveform with a duty cycle from 0% to 100% is output at the TIOCA pin. PWM mode can be selected in all channels (0 to 2).

Table 9.4 summarizes the PWM output pins and corresponding registers. If the same value is set in GRA and GRB, the output does not change when compare match occurs.

Table 9.4 PWM Output Pins and Registers

Channel	Output Pin	1 Output	0 Output
0	TIOCA ₀	GRA0	GRB0
1	TIOCA ₁	GRA1	GRB1
2	TIOCA ₂	GRA2	GRB2

Sample Setup Procedure for PWM Mode: Figure 9.26 shows a sample procedure for setting up PWM mode.

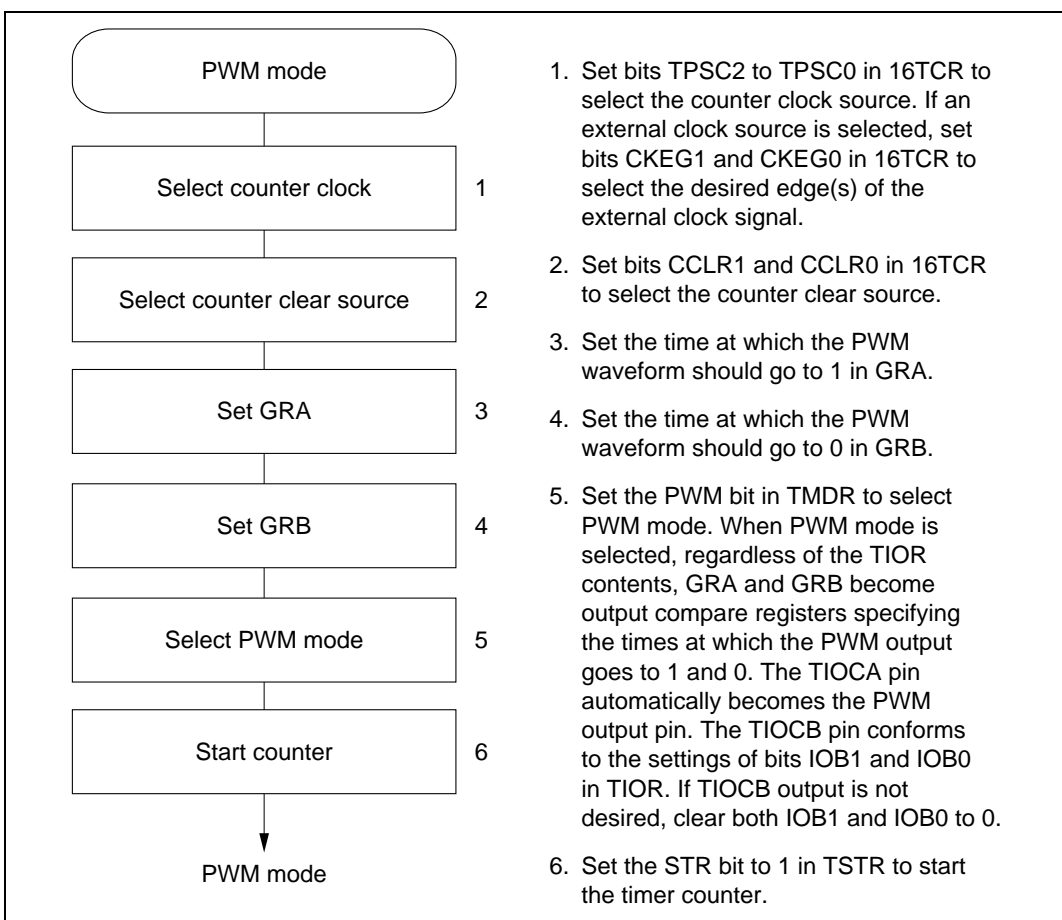
**Figure 9.26 Setup Procedure for PWM Mode (Example)**

Examples of PWM Mode: Figure 9.27 shows examples of operation in PWM mode. In PWM mode TIOCA becomes an output pin. The output goes to 1 at compare match with GRA, and to 0 at compare match with GRB.

In the examples shown, 16TCNT is cleared by compare match with GRA or GRB. Synchronized operation and free-running counting are also possible.

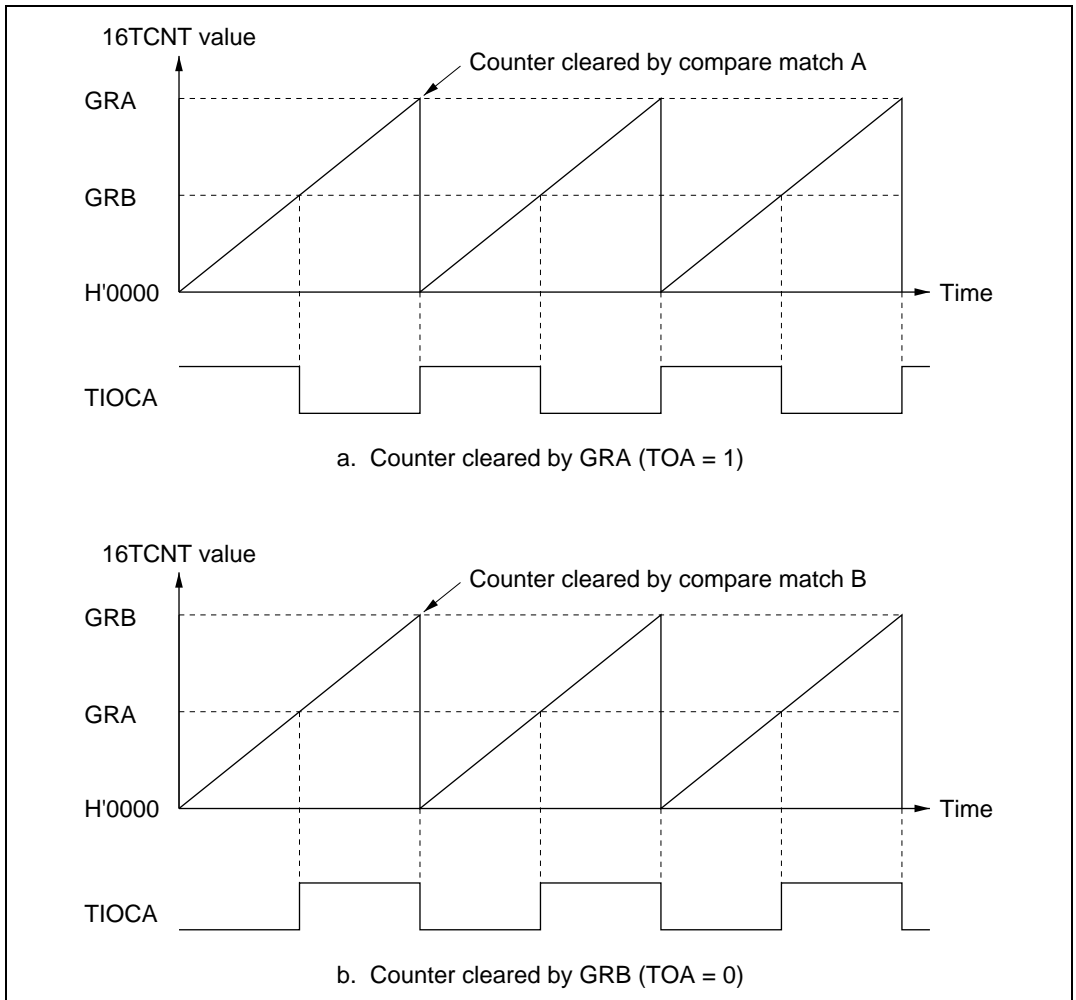

Figure 9.27 PWM Mode (Example 1)

Figure 9.28 shows examples of the output of PWM waveforms with duty cycles of 0% and 100%. If the counter is cleared by compare match with GRB, and GRA is set to a higher value than GRB, the duty cycle is 0%. If the counter is cleared by compare match with GRA, and GRB is set to a higher value than GRA, the duty cycle is 100%.

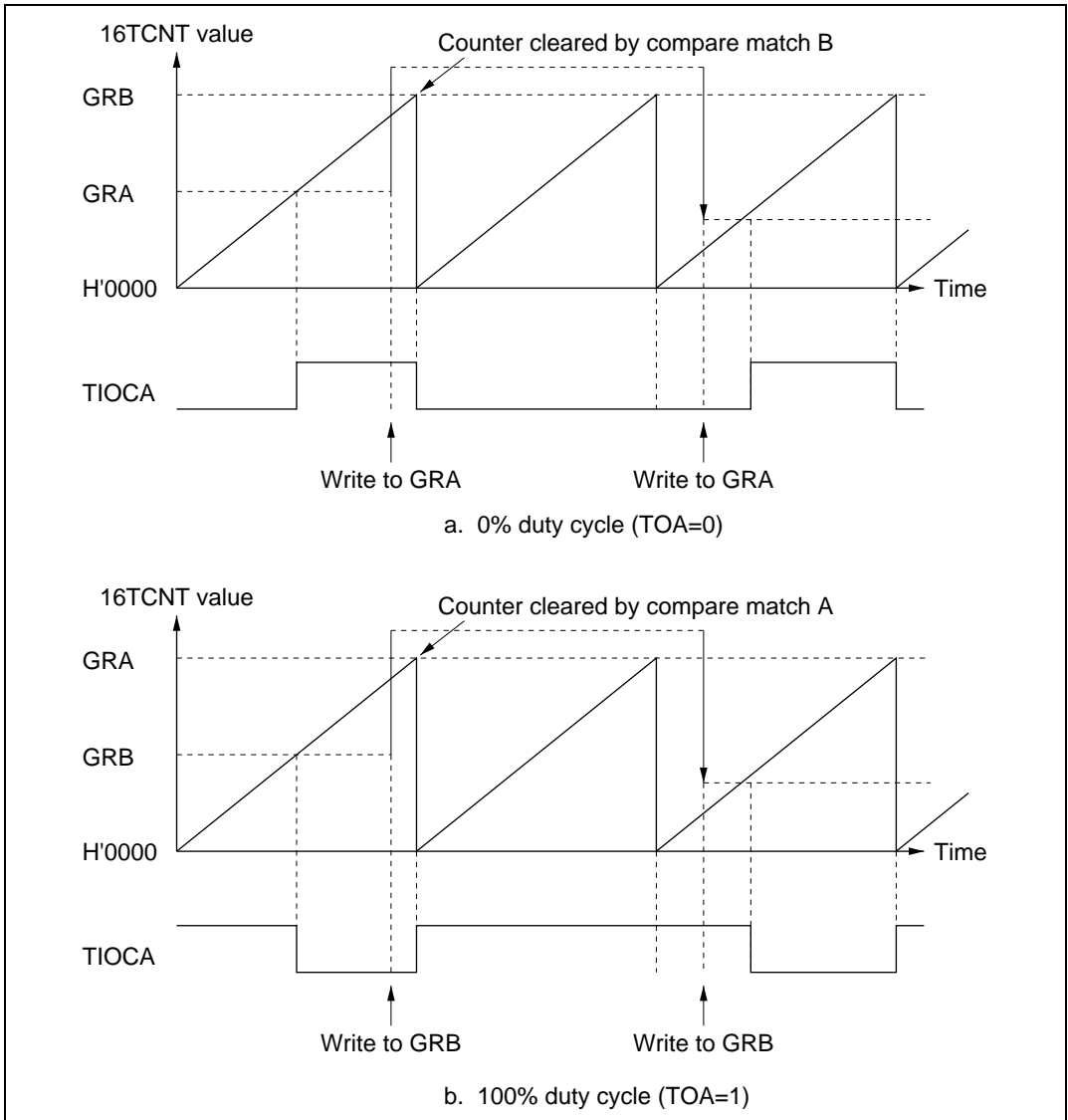

Figure 9.28 PWM Mode (Example 2)

9.4.5 Phase Counting Mode

In phase counting mode the phase difference between two external clock inputs (at the TCLKA and TCLKB pins) is detected, and 16TCNT2 counts up or down accordingly.

In phase counting mode, the TCLKA and TCLKB pins automatically function as external clock input pins and 16TCNT2 becomes an up/down-counter, regardless of the settings of bits TPSC2 to TPSC0, CKEG1, and CKEG0 in 16TCR2. Settings of bits CCLR1, CCLR0 in 16TCR2, and settings in TIOR2, TISRA, TISRB, TISRC, setting of STR2 bit in TSTR, GRA2, and GRB2 are valid. The input capture and output compare functions can be used, and interrupts can be generated.

Phase counting is available only in channel 2.

Sample Setup Procedure for Phase Counting Mode: Figure 9.29 shows a sample procedure for setting up phase counting mode.

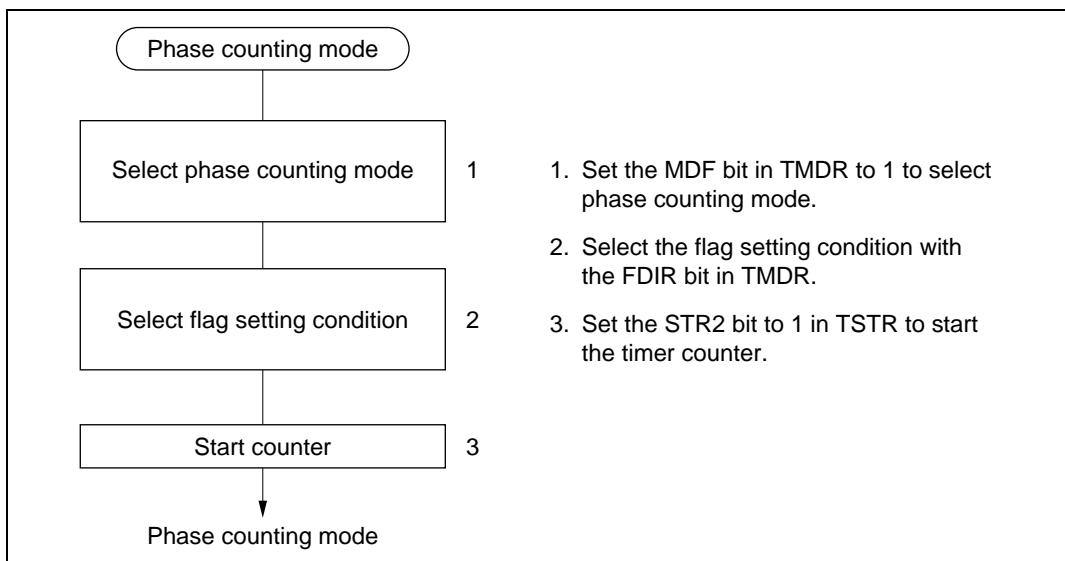

Figure 9.29 Setup Procedure for Phase Counting Mode (Example)

Example of Phase Counting Mode: Figure 9.30 shows an example of operations in phase counting mode. Table 9.5 lists the up-counting and down-counting conditions for 16TCNT2.

In phase counting mode both the rising and falling edges of TCLKA and TCLKB are counted. The phase difference between TCLKA and TCLKB must be at least 1.5 states, the phase overlap must also be at least 1.5 states, and the pulse width must be at least 2.5 states.

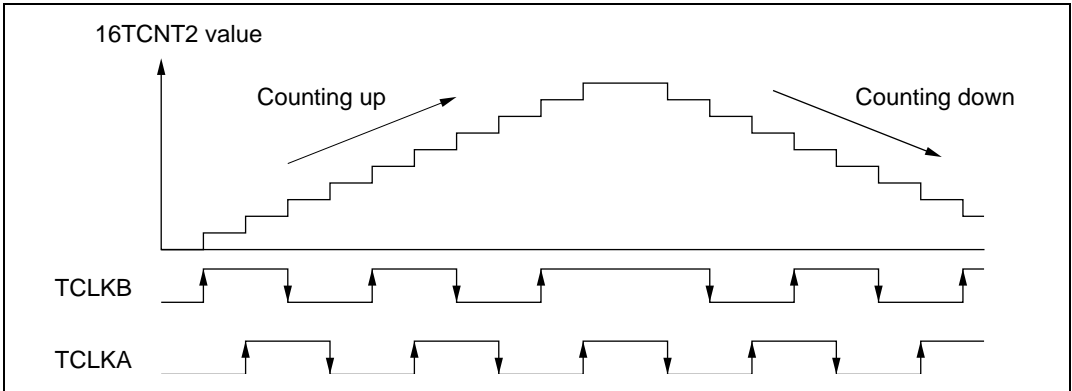

Figure 9.30 Operation in Phase Counting Mode (Example)

Table 9.5 Up/Down Counting Conditions

Counting Direction	Up-Counting				Down-Counting			
	TCLKB pin	High	Low	TCLKA pin	High	Low	TCLKB pin	High
Up-Counting	↑	High	↓	Low	High	↓	Low	↑
Down-Counting	↓	Low	↑	High	↓	Low	↑	High

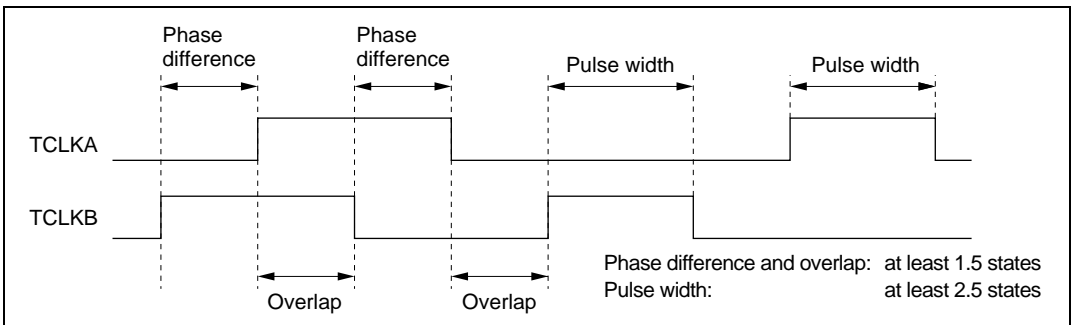

Figure 9.31 Phase Difference, Overlap, and Pulse Width in Phase Counting Mode

9.4.6 16-Bit Timer Output Timing

The initial value of 16-bit timer output when a timer count operation begins can be specified arbitrarily by making a setting in TOLR.

Figure 9.32 shows the timing for setting the initial value with TOLR.

Only write to TOLR when the corresponding bit in TSTR is cleared to 0.

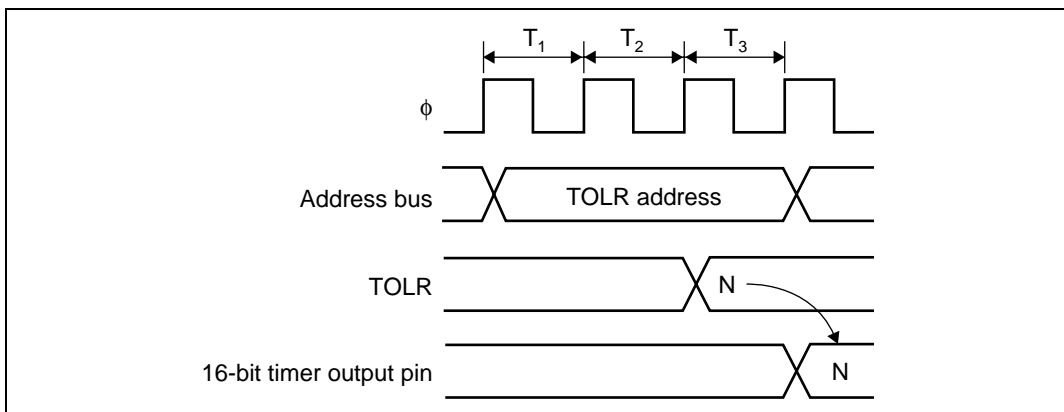

Figure 9.32 Timing for Setting 16-Bit Timer Output Level by Writing to TOLR

9.5 Interrupts

The 16-bit timer has two types of interrupts: input capture/compare match interrupts, and overflow interrupts.

9.5.1 Setting of Status Flags

Timing of Setting of IMFA and IMFB at Compare Match: IMFA and IMFB are set to 1 by a compare match signal generated when 16TCNT matches a general register (GR). The compare match signal is generated in the last state in which the values match (when 16TCNT is updated from the matching count to the next count). Therefore, when 16TCNT matches a general register, the compare match signal is not generated until the next 16TCNT clock input. Figure 9.33 shows the timing of the setting of IMFA and IMFB.

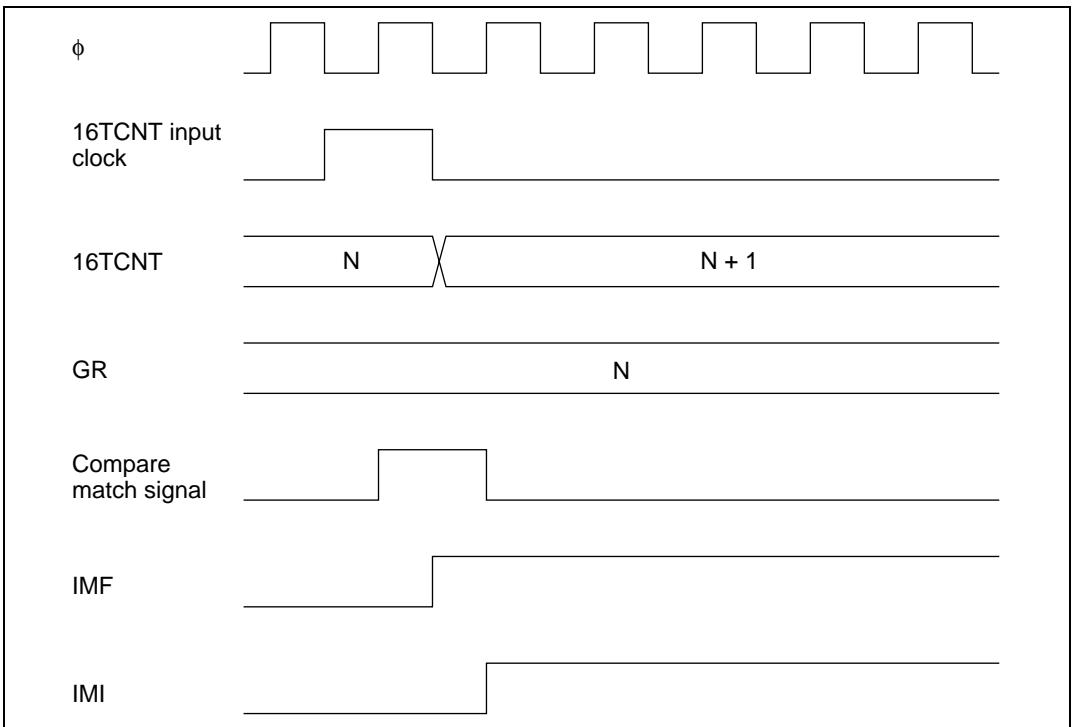

Figure 9.33 Timing of Setting of IMFA and IMFB by Compare Match

Timing of Setting of IMFA and IMFB by Input Capture: IMFA and IMFB are set to 1 by an input capture signal. The 16TCNT contents are simultaneously transferred to the corresponding general register. Figure 9.34 shows the timing.

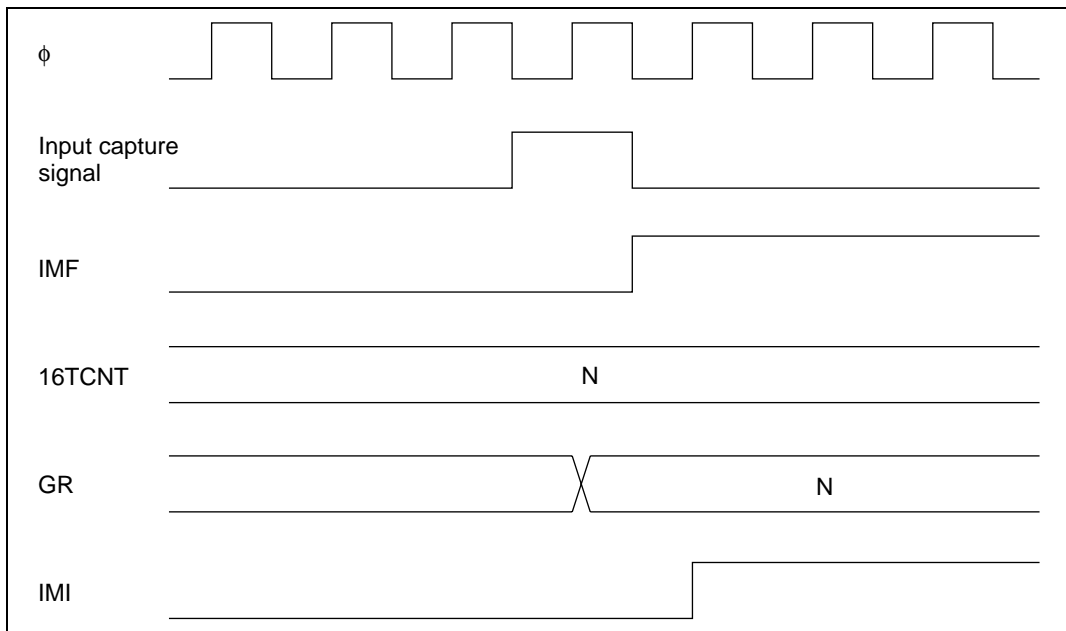

Figure 9.34 Timing of Setting of IMFA and IMFB by Input Capture

Timing of Setting of Overflow Flag (OVF): OVF is set to 1 when 16TCNT overflows from H'FFFF to H'0000 or underflows from H'0000 to H'FFFF. Figure 9.35 shows the timing.

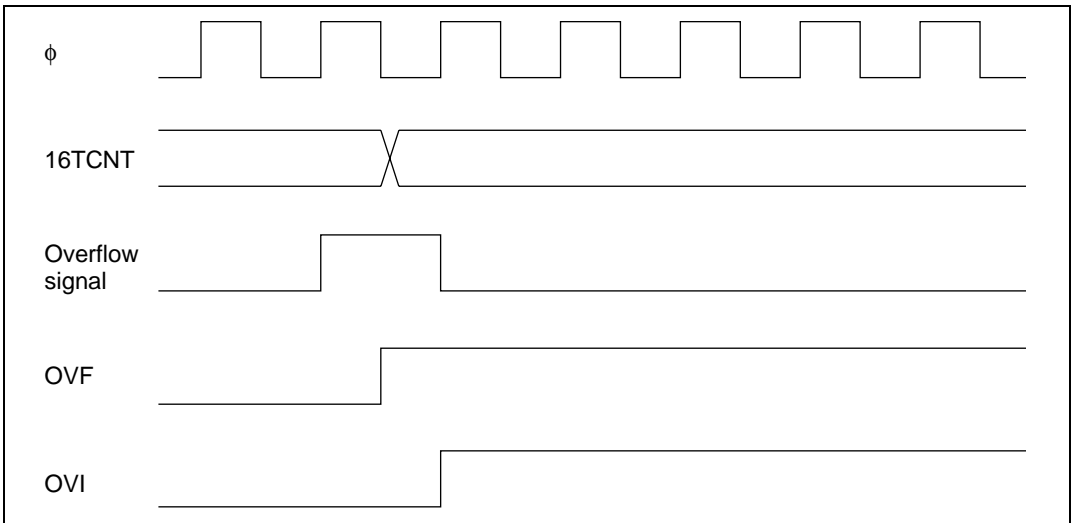

Figure 9.35 Timing of Setting of OVF

9.5.2 Timing of Clearing of Status Flags

If the CPU reads a status flag while it is set to 1, then writes 0 in the status flag, the status flag is cleared. Figure 9.36 shows the timing.

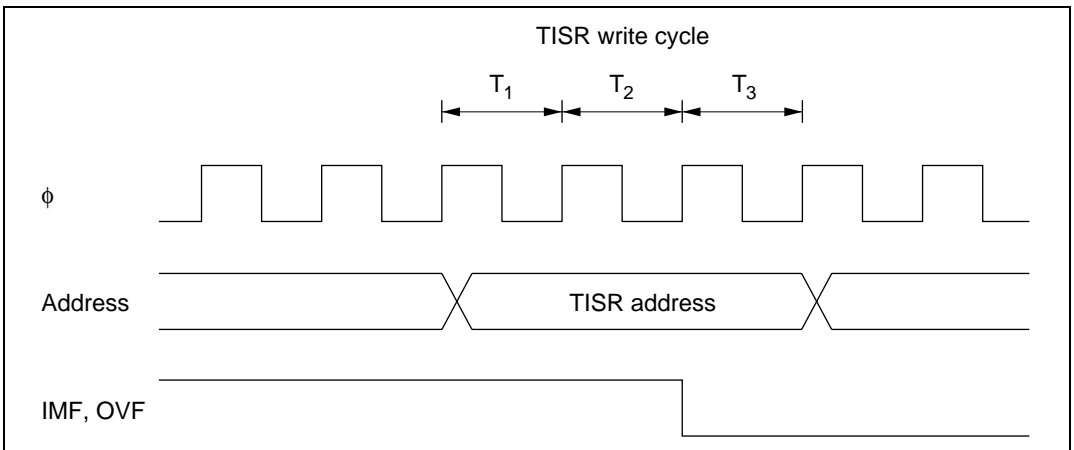

Figure 9.36 Timing of Clearing of Status Flags

9.5.3 Interrupt Sources

Each 16-bit timer channel can generate a compare match/input capture A interrupt, a compare match/input capture B interrupt, and an overflow interrupt. In total there are nine interrupt sources of three kinds, all independently vectored. An interrupt is requested when the interrupt request flag are set to 1.

The priority order of the channels can be modified in interrupt priority registers A (IPRA). For details see section 5, Interrupt Controller.

Table 9.6 lists the interrupt sources.

Table 9.6 16-bit timer Interrupt Sources

Channel	Interrupt Source	Description	Priority*
0	IMIA0	Compare match/input capture A0	High ↑ ↓ Low
	IMIB0	Compare match/input capture B0	
	OVI0	Overflow 0	
1	IMIA1	Compare match/input capture A1	↑ ↓ Low
	IMIB1	Compare match/input capture B1	
	OVI1	Overflow 1	
2	IMIA2	Compare match/input capture A2	↑ ↓ Low
	IMIB2	Compare match/input capture B2	
	OVI2	Overflow 2	

Note: * The priority immediately after a reset is indicated. Inter-channel priorities can be changed by settings in IPRA.

9.6 Usage Notes

This section describes contention and other matters requiring special attention during 16-bit timer operations.

Contention between 16TCNT Write and Clear: If a counter clear signal occurs in the T_3 state of a 16TCNT write cycle, clearing of the counter takes priority and the write is not performed.

See

figure 9.37.

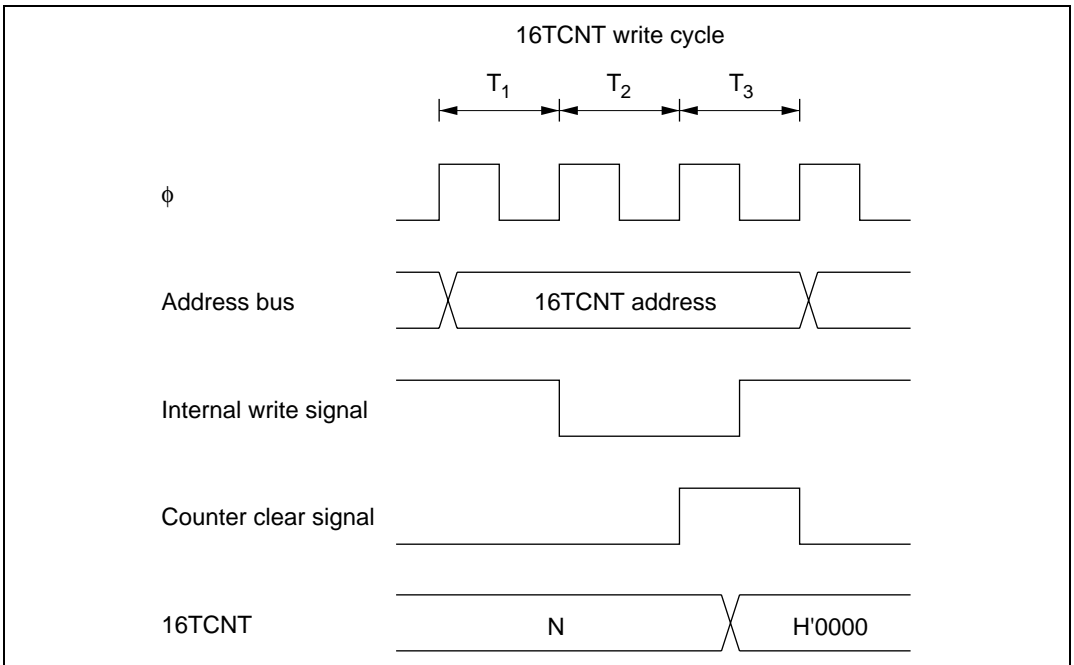

Figure 9.37 Contention between 16TCNT Write and Clear

Contention between 16TCNT Word Write and Increment: If an increment pulse occurs in the T_3 state of a 16TCNT word write cycle, writing takes priority and 16TCNT is not incremented. Figure 9.38 shows the timing in this case.

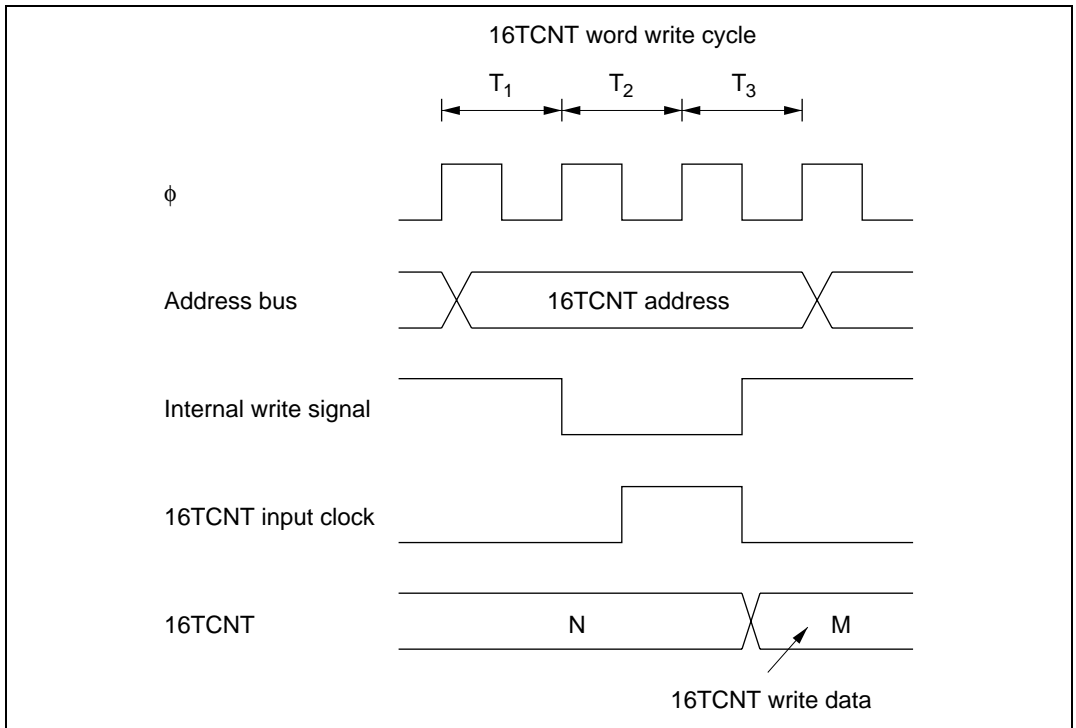

Figure 9.38 Contention between 16TCNT Word Write and Increment

Contention between 16TCNT Byte Write and Increment: If an increment pulse occurs in the T_2 or T_3 state of a 16TCNT byte write cycle, writing takes priority and 16TCNT is not incremented. The byte data for which a write was not performed is not incremented, and retains its pre-write value. See figure 9.39, which shows an increment pulse occurring in the T_2 state of a byte write to 16TCNTH.

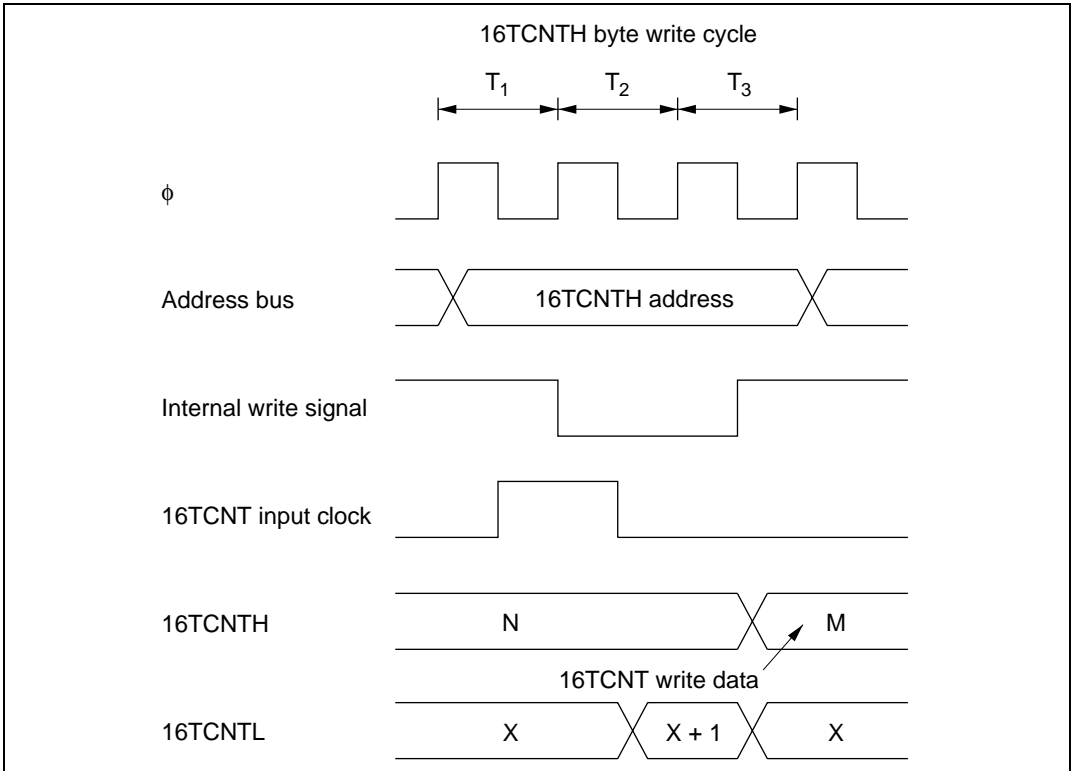

Figure 9.39 Contention between 16TCNT Byte Write and Increment

Contention between General Register Write and Compare Match: If a compare match occurs in the T_3 state of a general register write cycle, writing takes priority and the compare match signal is inhibited. See figure 9.40.

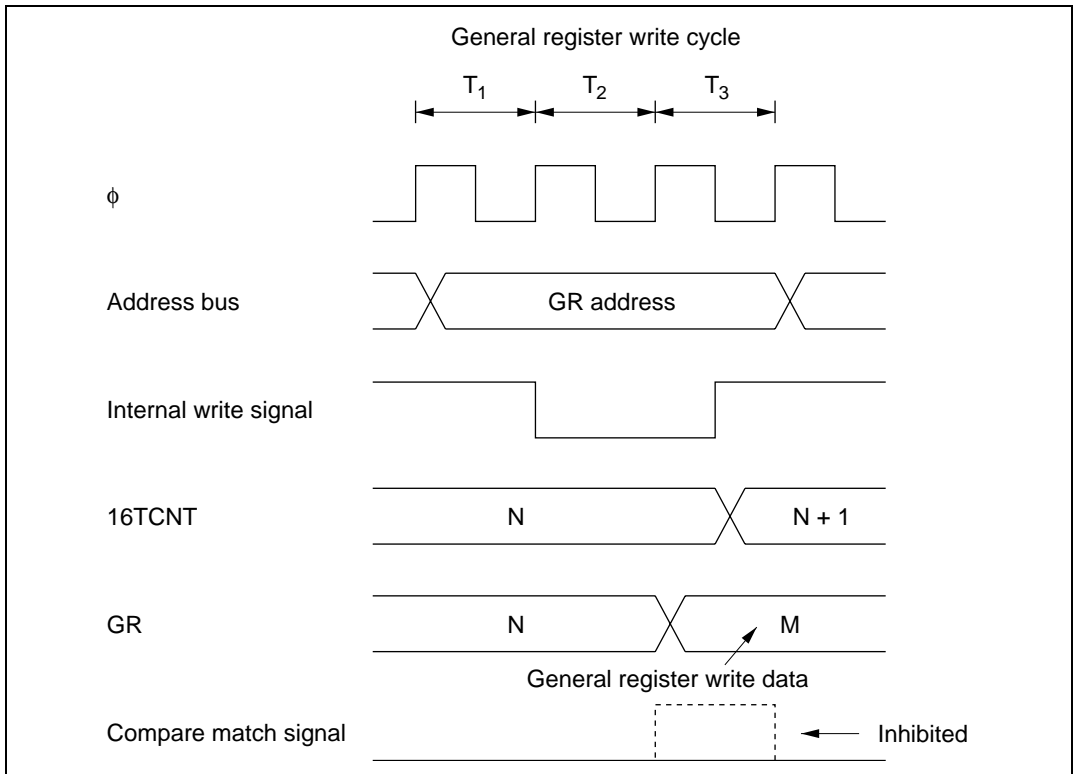

Figure 9.40 Contention between General Register Write and Compare Match

Contention between 16TCNT Write and Overflow or Underflow: If an overflow occurs in the T_3 state of a 16TCNT write cycle, writing takes priority and the counter is not incremented. OVF is set to 1. The same holds for underflow. See figure 9.41.

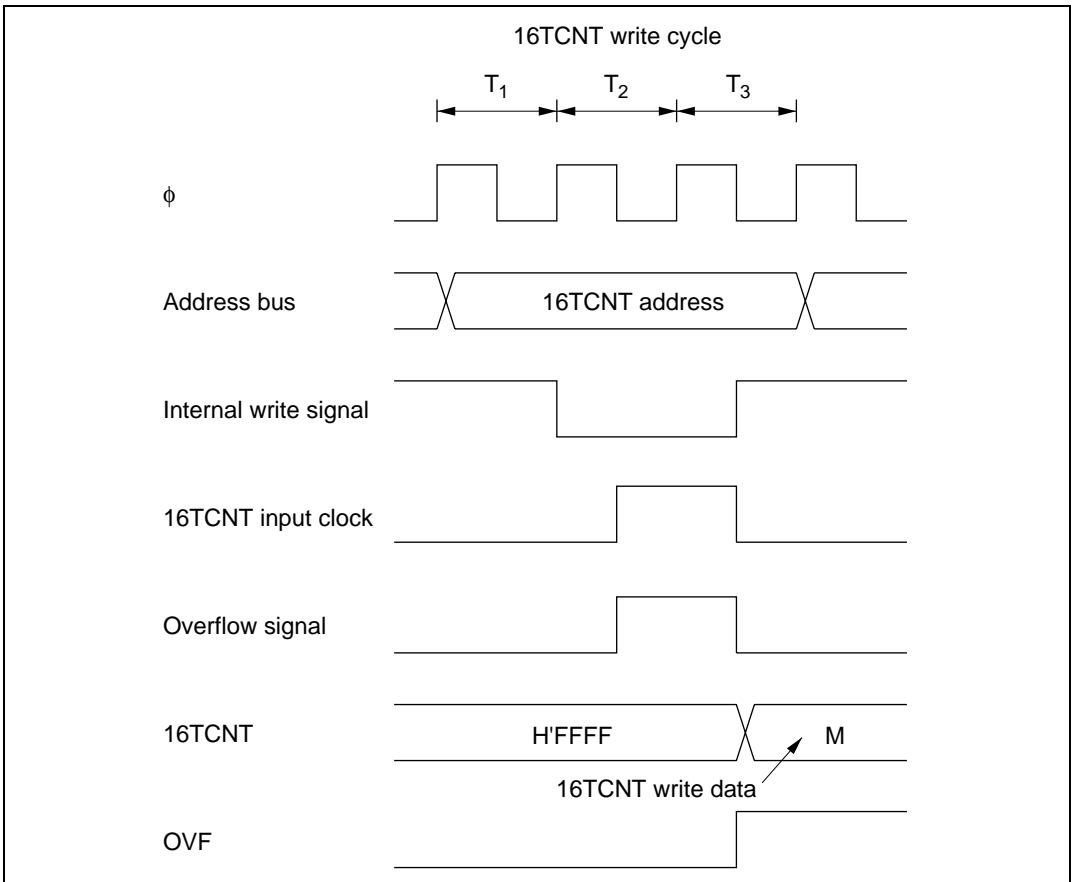

Figure 9.41 Contention between 16TCNT Write and Overflow

Contention between General Register Read and Input Capture: If an input capture signal occurs during the T_3 state of a general register read cycle, the value before input capture is read. See figure 9.42.

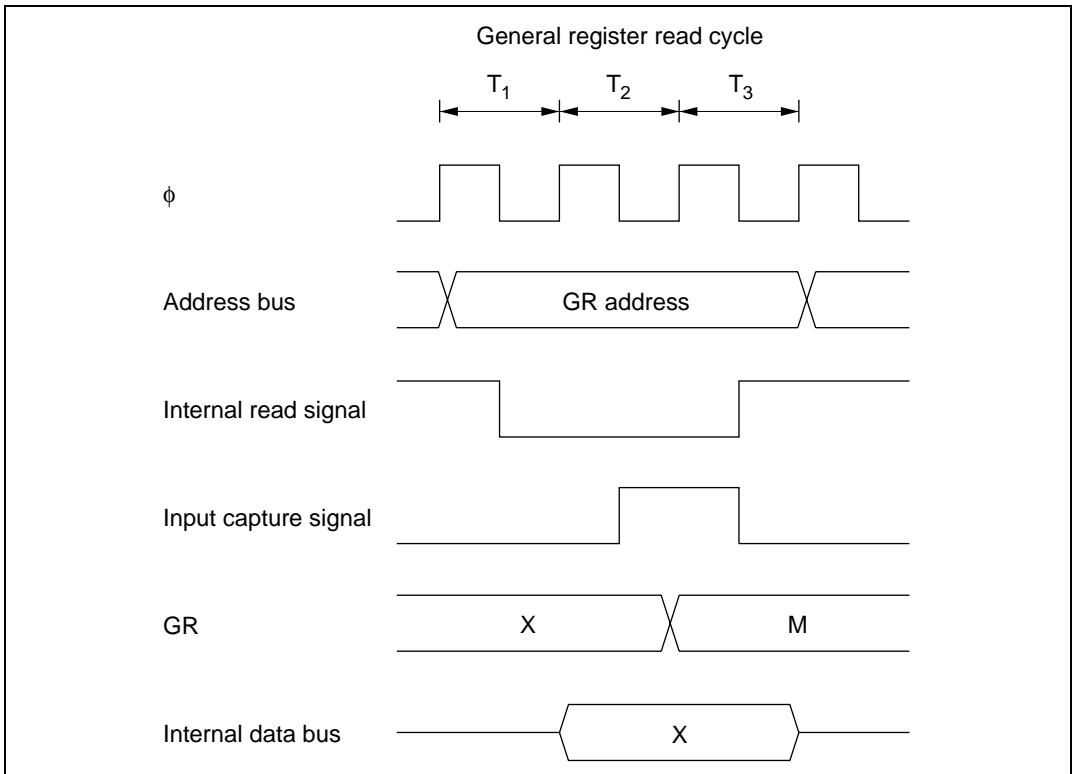

Figure 9.42 Contention between General Register Read and Input Capture

Contention between Counter Clearing by Input Capture and Counter Increment: If an input capture signal and counter increment signal occur simultaneously, the counter is cleared according to the input capture signal. The counter is not incremented by the increment signal. The value before the counter is cleared is transferred to the general register. See figure 9.43.

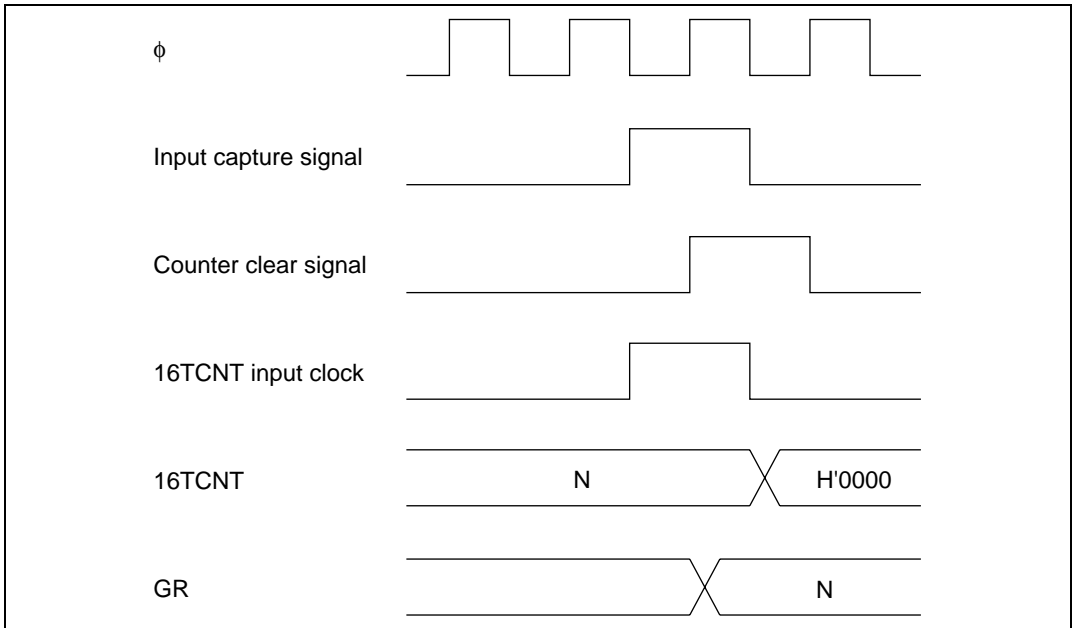

Figure 9.43 Contention between Counter Clearing by Input Capture and Counter Increment

Contention between General Register Write and Input Capture: If an input capture signal occurs in the T_3 state of a general register write cycle, input capture takes priority and the write to the general register is not performed. See figure 9.44.

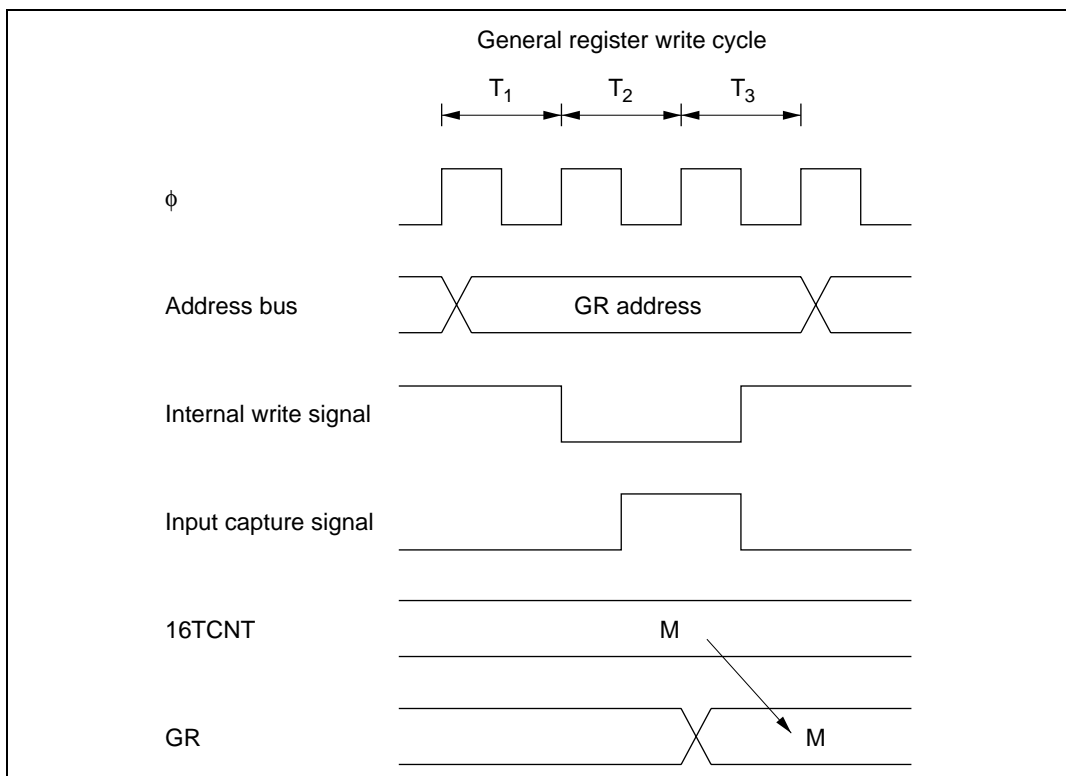

Figure 9.44 Contention between General Register Write and Input Capture

Note on Waveform Period Setting: When a counter is cleared by compare match, the counter is cleared in the last state at which the 16TCNT value matches the general register value, at the time when this value would normally be updated to the next count. The actual counter frequency is therefore given by the following formula:

$$f = \frac{\phi}{(N+1)}$$

(f: counter frequency. ϕ : system clock frequency. N: value set in general register.)

Note on Writes in Synchronized Operation: When channels are synchronized, if a 16TCNT value is modified by byte write access, all 16 bits of all synchronized counters assume the same value as the counter that was addressed.

(Example) When channels 1 and 2 are synchronized

- Byte write to channel 1 or byte write to channel 2

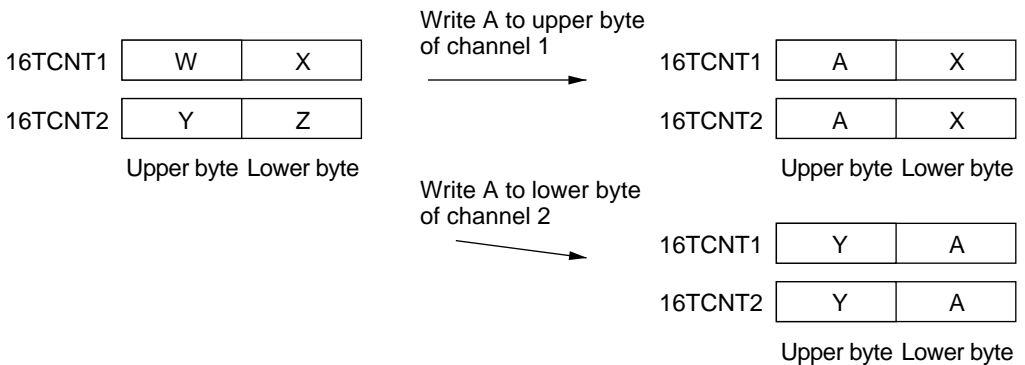

- Word write to channel 1 or word write to channel 2

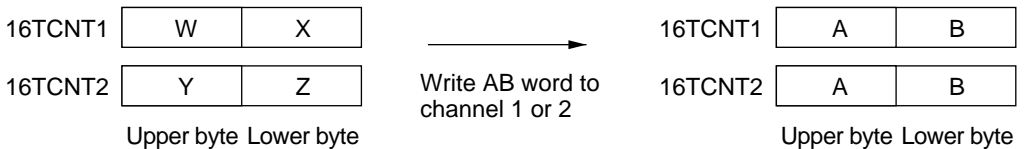

16-bit timer Operating Modes

Table 9.7 (a) 16-bit timer Operating Modes (Channel 0)

Operating Mode		Register Settings							
		TSNC	TMDR			TIOR0		16TCR0	
		Synchro- nization	MDF	FDIR	PWM	IOA	IOB	Clear Select	Clock Select
Synchronous preset		SYNC0 = 1	—	—	○	○	○	○	○
PWM mode		○	—	—	PWM0 = 1	—	○*	○	○
Output compare A		○	—	—	PWM0 = 0	IOA2 = 0 Other bits unrestricted	○	○	○
Output compare B		○	—	—	○	○	IOB2 = 0 Other bits unrestricted	○	○
Input capture A		○	—	—	PWM0 = 0	IOA2 = 1 Other bits unrestricted	○	○	○
Input capture B		○	—	—	PWM0 = 0	○	IOB2 = 1 Other bits unrestricted	○	○
Counter clearing	By compare match/input capture A	○	—	—	○	○	○	CCLR1 = 0 CCLR0 = 1	○
	By compare match/input capture B	○	—	—	○	○	○	CCLR1 = 1 CCLR0 = 0	○
	Syn- chronous clear	SYNC0 = 1	—	—	○	○	○	CCLR1 = 1 CCLR0 = 1	○

Legend: ○ Setting available (valid). — Setting does not affect this mode.

Note: * The input capture function cannot be used in PWM mode. If compare match A and compare match B occur simultaneously, the compare match signal is inhibited.

Table 9.7 (b) 16-bit timer Operating Modes (Channel 1)

Operating Mode	Register Settings							
	TSNC	TMDR			TIOR1		16TCR1	
	Synchro- nization	MDF	FDIR	PWM	IOA	IOB	Clear Select	Clock Select
Synchronous preset	SYNC1 = 1	—	—	○	○	○	○	○
PWM mode	○	—	—	PWM1 = 1	—	○*	○	○
Output compare A	○	—	—	PWM1 = 0	IOA2 = 0 Other bits unrestricted	○	○	○
Output compare B	○	—	—	○	○	IOB2 = 0 Other bits unrestricted	○	○
Input capture A	○	—	—	PWM1 = 0	IOA2 = 1 Other bits unrestricted	○	○	○
Input capture B	○	—	—	PWM1 = 0	○	IOB2 = 1 Other bits unrestricted	○	○
Counter clearing	By compare match/input capture A	○	—	—	○	○	CCLR1 = 0 CCLR0 = 1	○
	By compare match/input capture B	○	—	—	○	○	CCLR1 = 1 CCLR0 = 0	○
	Synchronous clear	SYNC1 = 1	—	—	○	○	CCLR1 = 1 CCLR0 = 1	○

Legend: ○ Setting available (valid). — Setting does not affect this mode.

Note: * The input capture function cannot be used in PWM mode. If compare match A and compare match B occur simultaneously, the compare match signal is inhibited.

Table 9.7 (c) 16-bit timer Operating Modes (Channel 2)

Operating Mode	Register Settings							
	TSNC	TMDR			TIOA2		16TCR2	
	Synchro- nization	MDF	FDIR	PWM	IOA	IOB	Clear Select	Clock Select
Synchronous preset	SYNC2 = 1	○	—	○	○	○	○	○
PWM mode	○	○	—	PWM2 = 1	—	○*	○	○
Output compare A	○	○	—	PWM2 = 0	IOA2 = 0 Other bits unrestricted	○	○	○
Output compare B	○	○	—	○	○	IOB2 = 0 Other bits unrestricted	○	○
Input capture A	○	○	—	PWM2 = 0	IOA2 = 1 Other bits unrestricted	○	○	○
Input capture B	○	○	—	PWM2 = 0	○	IOB2 = 1 Other bits unrestricted	○	○
Counter clearing	By compare match/input capture A	○	○	—	○	○	CCLR1 = 0 CCLR0 = 1	○
	By compare match/input capture B	○	○	—	○	○	CCLR1 = 1 CCLR0 = 0	○
	Syn-chronous clear	SYNC2 = 1	○	—	○	○	CCLR1 = 1 CCLR0 = 1	○
Phase counting mode	○	MDF = 1	○	○	○	○	○	—

Legend: ○ Setting available (valid). — Setting does not affect this mode.

Note: * The input capture function cannot be used in PWM mode. If compare match A and compare match B occur simultaneously, the compare match signal is inhibited.

Section 10 8-Bit Timers

10.1 Overview

The H8/3068F has a built-in 8-bit timer module with four channels (TMR0, TMR1, TMR2, and TMR3), based on 8-bit counters. Each channel has an 8-bit timer counter (8TCNT) and two 8-bit time constant registers (TCORA and TCORB) that are constantly compared with the 8TCNT value to detect compare match events. The timers can be used as multifunctional timers in a variety of applications, including the generation of a rectangular-wave output with an arbitrary duty cycle.

10.1.1 Features

The features of the 8-bit timer module are listed below.

- Selection of four clock sources
The counters can be driven by one of three internal clock signals ($\phi/8$, $\phi/64$, or $\phi/8192$) or an external clock input (enabling use as an external event counter).
- Selection of three ways to clear the counters
The counters can be cleared on compare match A or B, or input capture B.
- Timer output controlled by two compare match signals
The timer output signal in each channel is controlled by two independent compare match signals, enabling the timer to generate output waveforms with an arbitrary duty cycle or PWM output.
- A/D converter can be activated by a compare match
- Two channels can be cascaded
 - Channels 0 and 1 can be operated as the upper and lower halves of a 16-bit timer (16-bit count mode).
 - Channels 2 and 3 can be operated as the upper and lower halves of a 16-bit timer (16-bit count mode).
 - Channel 1 can count channel 0 compare match events (compare match count mode).
 - Channel 3 can count channel 2 compare match events (compare match count mode).
- Input capture function can be set
8-bit or 16-bit input capture operation is available.

- Twelve interrupt sources

There are twelve interrupt sources: four compare match sources, four compare match/input capture sources, four overflow sources.

Two of the compare match sources and two of the combined compare match/input capture sources each have an independent interrupt vector. The remaining compare match interrupts, combined compare match/input capture interrupts, and overflow interrupts have one interrupt vector for two sources.

10.1.2 Block Diagram

The 8-bit timers are divided into two groups of two channels each: group 0 comprising channels 0 and 1, and group 1 comprising channels 2 and 3. Figure 10.1 shows a block diagram of 8-bit timer group 0.

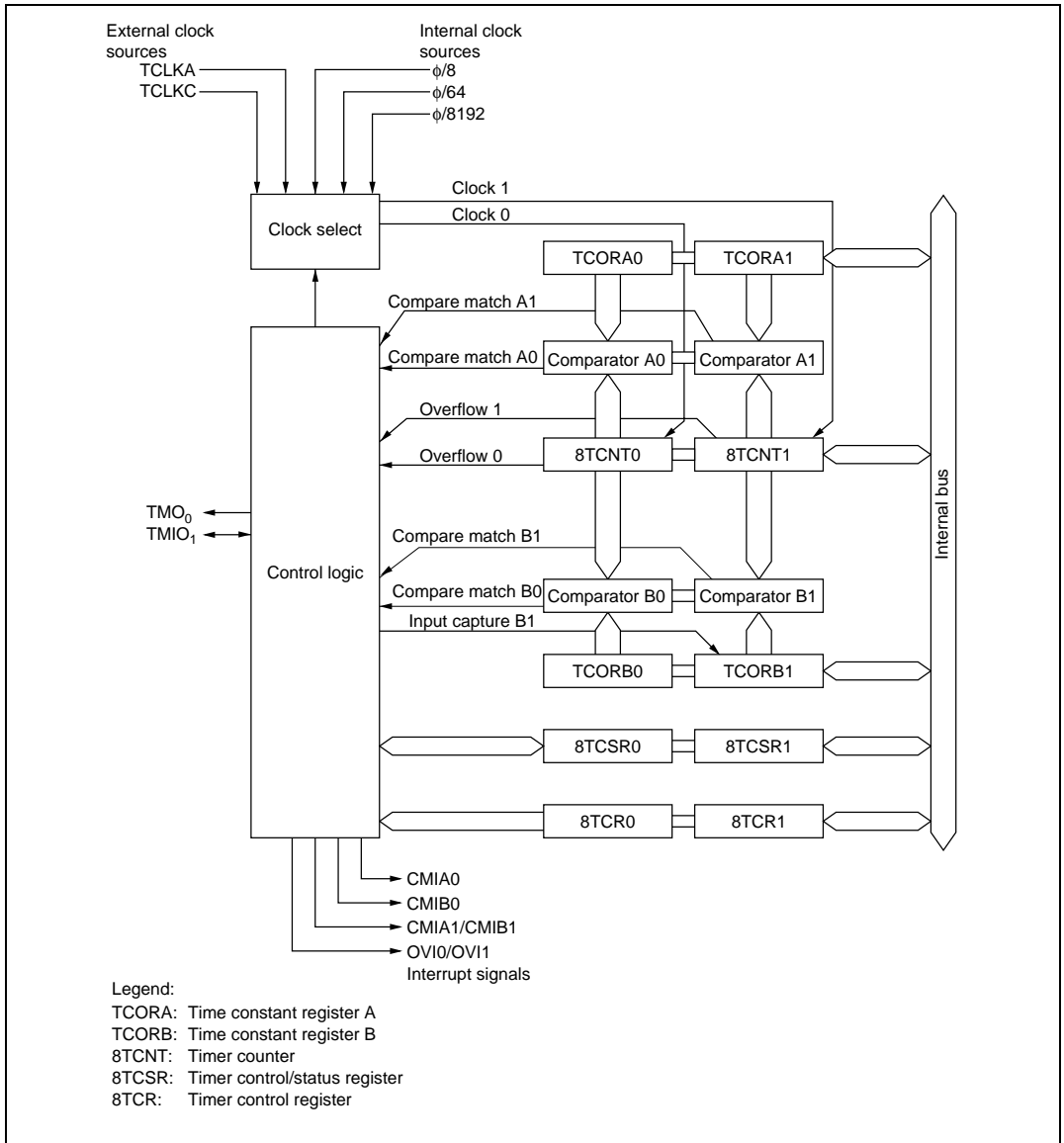

Figure 10.1 Block Diagram of 8-Bit Timer Unit (Two Channels: Group 0)

10.1.3 Pin Configuration

Table 10.1 summarizes the input/output pins of the 8-bit timer module.

Table 10.1 8-Bit Timer Pins

Group	Channel	Name	Abbreviation	I/O	Function
0	0	Timer output	TMO ₀	Output	Compare match output
		Timer clock input	TCLKC	Input	Counter external clock input
	1	Timer input/output	TMIO ₁	I/O	Compare match output/input capture input
		Timer clock input	TCLKA	Input	Counter external clock input
1	2	Timer output	TMO ₂	Output	Compare match output
		Timer clock input	TCLKD	Input	Counter external clock input
	3	Timer input/output	TMIO ₃	I/O	Compare match output/input capture input
		Timer clock input	TCLKB	Input	Counter external clock input

10.1.4 Register Configuration

Table 10.2 summarizes the registers of the 8-bit timer module.

Table 10.2 8-Bit Timer Registers

Channel	Address* ¹	Name	Abbreviation	R/W	Initial value
0	H'FFF80	Timer control register 0	8TCR0	R/W	H'00
	H'FFF82	Timer control/status register 0	8TCSR0	R/(W)* ²	H'00
	H'FFF84	Time constant register A0	TCORA0	R/W	H'FF
	H'FFF86	Time constant register B0	TCORB0	R/W	H'FF
	H'FFF88	Timer counter 0	8TCNT0	R/W	H'00
1	H'FFF81	Timer control register 1	8TCR1	R/W	H'00
	H'FFF83	Timer control/status register 1	8TCSR1	R/(W)* ²	H'00
	H'FFF85	Time constant register A1	TCORA1	R/W	H'FF
	H'FFF87	Time constant register B1	TCORB1	R/W	H'FF
	H'FFF89	Timer counter 1	8TCNT1	R/W	H'00
2	H'FFF90	Timer control register 2	8TCR2	R/W	H'00
	H'FFF92	Timer control/status register 2	8TCSR2	R/(W)* ²	H'10
	H'FFF94	Time constant register A2	TCORA2	R/W	H'FF
	H'FFF96	Time constant register B2	TCORB2	R/W	H'FF
	H'FFF98	Timer counter 2	8TCNT2	R/W	H'00
3	H'FFF91	Timer control register 3	8TCR3	R/W	H'00
	H'FFF93	Timer control/status register 3	8TCSR3	R/(W)* ²	H'00
	H'FFF95	Time constant register A3	TCORA3	R/W	H'FF
	H'FFF97	Time constant register B3	TCORB3	R/W	H'FF
	H'FFF99	Timer counter 3	8TCNT3	R/W	H'00

Notes: 1. Indicates the lower 20 bits of the address in advanced mode.

2. Only 0 can be written to bits 7 to 5, to clear these flags.

Each pair of registers for channel 0 and channel 1 comprises a 16-bit register with the channel 0 register as the upper 8 bits and the channel 1 register as the lower 8 bits, so they can be accessed together by word access.

Similarly, each pair of registers for channel 2 and channel 3 comprises a 16-bit register with the channel 2 register as the upper 8 bits and the channel 3 register as the lower 8 bits, so they can be accessed together by word access.

10.2 Register Descriptions

10.2.1 Timer Counters (8TCNT)

8TCNT0								8TCNT1								
Bit	15	14	13	12	11	10	9	8	7	6	5	4	3	2	1	0
Initial value	0	0	0	0	0	0	0	0	0	0	0	0	0	0	0	0
Read/Write	R/W	R/W	R/W	R/W	R/W	R/W	R/W	R/W	R/W	R/W	R/W	R/W	R/W	R/W	R/W	R/W

8TCNT2								8TCNT3								
Bit	15	14	13	12	11	10	9	8	7	6	5	4	3	2	1	0
Initial value	0	0	0	0	0	0	0	0	0	0	0	0	0	0	0	0
Read/Write	R/W	R/W	R/W	R/W	R/W	R/W	R/W	R/W	R/W	R/W	R/W	R/W	R/W	R/W	R/W	R/W

The timer counters (8TCNT) are 8-bit readable/writable up-counters that increment on pulses generated from an internal or external clock source. The clock source is selected by clock select bits 2 to 0 (CKS2 to CKS0) in the timer control register (8TCR). The CPU can always read or write to the timer counters.

The 8TCNT0 and 8TCNT1 pair, and the 8TCNT2 and 8TCNT3 pair, can each be accessed as a 16-bit register by word access.

8TCNT can be cleared by an input capture signal or compare match signal. Counter clear bits 1 and 0 (CCLR1 and CCLR0) in 8TCR select the method of clearing.

When 8TCNT overflows from H'FF to H'00, the overflow flag (OVF) in the timer control/status register (8TCSR) is set to 1.

Each 8TCNT is initialized to H'00 by a reset and in standby mode.

10.2.2 Time Constant Registers A (TCORA)

TCORA0 to TCORA3 are 8-bit readable/writable registers.

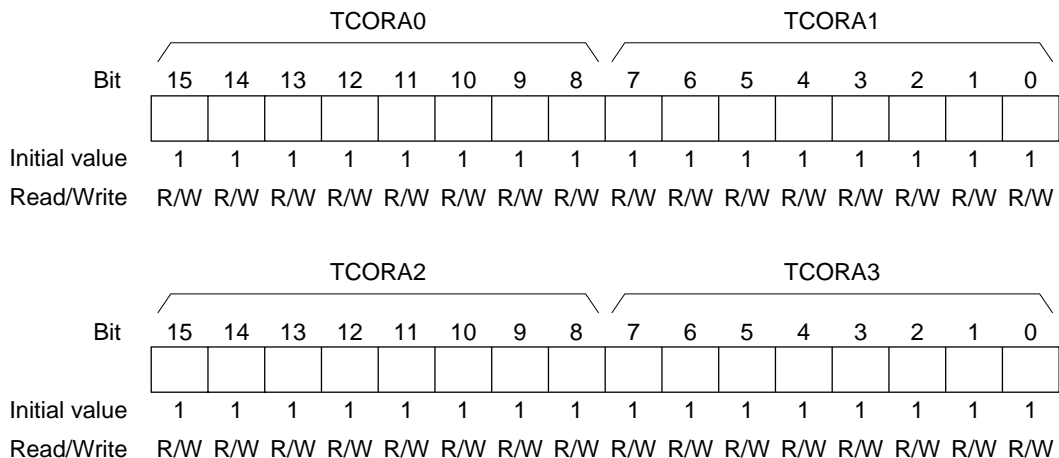

The TCORA0 and TCORA1 pair, and the TCORA2 and TCORA3 pair, can each be accessed as a 16-bit register by word access.

The TCORA value is constantly compared with the 8TCNT value. When a match is detected, the corresponding compare match flag A (CMFA) is set to 1 in 8TCSR.

The timer output can be freely controlled by these compare match signals and the settings of output select bits 1 and 0 (OS1, OS0) in 8TCSR.

Each TCORA register is initialized to H'FF by a reset and in standby mode.

10.2.3 Time Constant Registers B (TCORB)

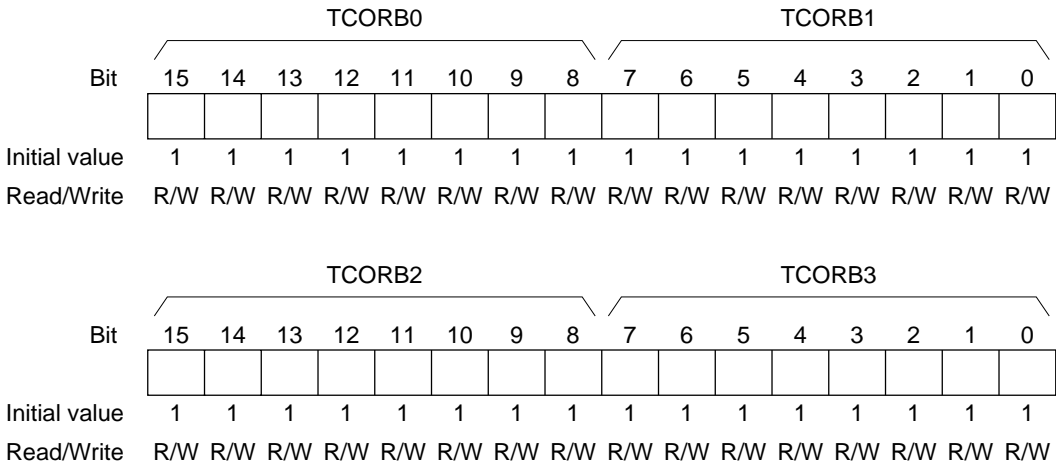

TCORB0 to TCORB3 are 8-bit readable/writable registers. The TCORB0 and TCORB1 pair, and the TCORB2 and TCORB3 pair, can each be accessed as a 16-bit register by word access.

The TCORB value is constantly compared with the 8TCNT value. When a match is detected, the corresponding compare match flag B (CMFB) is set to 1 in 8TCSR*.

The timer output can be freely controlled by these compare match signals and the settings of output/input capture edge select bits 3 and 2 (OIS3, OIS2) in 8TCSR.

When TCORB is used for input capture, it stores the 8TCNT value on detection of an external input capture signal. At this time, the CMFB flag is set to 1 in the corresponding 8TCSR register. The detected edge of the input capture signal is set in 8TCSR.

Each TCORB register is initialized to H'FF by a reset and in standby mode.

Note: * When channel 1 and channel 3 are designated for TCORB input capture, the CMFB flag is not set by a channel 0 or channel 2 compare match B.

10.2.4 Timer Control Register (8TCR)

Bit	7	6	5	4	3	2	1	0
	CMIEB	CMIEA	OVIE	CCLR1	CCLR0	CKS2	CKS1	CKS0
Initial value	0	0	0	0	0	0	0	0
Read/Write	R/W	R/W	R/W	R/W	R/W	R/W	R/W	R/W

8TCR is an 8-bit readable/writable register that selects the 8TCNT input clock, gives the 8TCNT clearing specification, and enables interrupt requests.

8TCR is initialized to H'00 by a reset and in standby mode.

For the timing, see section 10.4, Operation.

Bit 7—Compare Match Interrupt Enable B (CMIEB): Enables or disables the CMIB interrupt request when the CMFB flag is set to 1 in 8TCSR.

Bit 7

CMIEB	Description
0	CMIB interrupt requested by CMFB is disabled (Initial value)
1	CMIB interrupt requested by CMFB is enabled

Bit 6—Compare Match Interrupt Enable A (CMIEA): Enables or disables the CMIA interrupt request when the CMFA flag is set to 1 in 8TCSR.

Bit 6

CMIEA	Description
0	CMIA interrupt requested by CMFA is disabled (Initial value)
1	CMIA interrupt requested by CMFA is enabled

Bit 5—Timer Overflow Interrupt Enable (OVIE): Enables or disables the OVI interrupt request when the OVF flag is set to 1 in 8TCSR.

Bit 5

OVIE	Description
0	OVI interrupt requested by OVF is disabled (Initial value)
1	OVI interrupt requested by OVF is enabled

Bits 4 and 3—Counter Clear 1 and 0 (CCLR1, CCLR0): These bits specify the 8TCNT clearing source. Compare match A or B, or input capture B, can be selected as the clearing source.

Bit 4 CCLR1	Bit 3 CCLR0	Description	
0	0	Clearing is disabled	(Initial value)
	1	Cleared by compare match A	
1	0	Cleared by compare match B/input capture B	
	1	Cleared by input capture B	

Note: When input capture B is set as the 8TCNT1 and 8TCNT3 counter clear source, 8TCNT0 and 8TCNT2 are not cleared by compare match B.

Bits 2 to 0—Clock Select 2 to 0 (CSK2 to CSK0): These bits select whether the clock input to 8TCNT is an internal or external clock.

Three internal clocks can be selected, all divided from the system clock (ϕ): $\phi/8$, $\phi/64$, and $\phi/8192$. The rising edge of the selected internal clock triggers the count.

When use of an external clock is selected, three types of count can be selected: at the rising edge, the falling edge, and both rising and falling edges.

When $CKS2, CKS1, CKS0 = 1, 0, 0$, channels 0 and 1 and channels 2 and 3 are cascaded.

The incrementing clock source is different when 8TCR0 and 8TCR2 are set, and when 8TCR1 and 8TCR3 are set.

Bit 2 CSK2	Bit 1 CSK1	Bit 0 CSK0	Description	
0	0	0	Clock input disabled (Initial value)	
		1	Internal clock, counted on falling edge of $\phi/8$	
	1	0	Internal clock, counted on falling edge of $\phi/64$	
		1	Internal clock, counted on falling edge of $\phi/8192$	
1	0	0	Channel 0 (16-bit count mode): Count on 8TCNT1 overflow signal* ¹ Channel 1 (compare match count mode): Count on 8TCNT0 compare match A* ¹ Channel 2 (16-bit count mode): Count on 8TCNT3 overflow signal* ² Channel 3 (compare match count mode): Count on 8TCNT2 compare match A* ²	
		1	External clock, counted on rising edge	
		1	0	External clock, counted on falling edge
			1	External clock, counted on both rising and falling edges

- Notes:
1. If the clock input of channel 0 is the 8TCNT1 overflow signal and that of channel 1 is the 8TCNT0 compare match signal, no incrementing clock is generated. Do not use this setting.
 2. If the clock input of channel 2 is the 8TCNT3 overflow signal and that of channel 3 is the 8TCNT2 compare match signal, no incrementing clock is generated. Do not use this setting.

10.2.5 Timer Control/Status Registers (8TCSR)

8TCSR0

Bit	7	6	5	4	3	2	1	0
	CMFB	CMFA	OVF	ADTE	OIS3	OIS2	OS1	OS0
Initial value	0	0	0	0	0	0	0	0
Read/Write	R/(W)*	R/(W)*	R/(W)*	R/W	R/W	R/W	R/W	R/W

8TCSR2

Bit	7	6	5	4	3	2	1	0
	CMFB	CMFA	OVF	—	OIS3	OIS2	OS1	OS0
Initial value	0	0	0	1	0	0	0	0
Read/Write	R/(W)*	R/(W)*	R/(W)*	—	R/W	R/W	R/W	R/W

8TCSR1, 8TCSR3

Bit	7	6	5	4	3	2	1	0
	CMFB	CMFA	OVF	ICE	OIS3	OIS2	OS1	OS0
Initial value	0	0	0	0	0	0	0	0
Read/Write	R/(W)*	R/(W)*	R/(W)*	R/W	R/W	R/W	R/W	R/W

Note: * Only 0 can be written to bits 7 to 5, to clear these flags.

The timer control/status registers 8TCSR are 8-bit registers that indicate compare match/input capture and overflow statuses, and control compare match output/input capture edge selection.

8TCSR2 is initialized to H'10, and 8TCSR0, 8TCSR1, and 8TCSR3 to H'00, by a reset and in standby mode.

Bit 7—Compare Match/Input Capture Flag B (CMFB): Status flag that indicates the occurrence of a TCORB compare match or input capture.

Bit 7 CMFB	Description	
0	[Clearing condition] Read CMFB when CMFB = 1, then write 0 in CMFB	(Initial value)
1	[Setting conditions] <ul style="list-style-type: none"> • 8TCNT = TCORB* • The 8TCNT value is transferred to TCORB by an input capture signal when TCORB functions as an input capture register 	

Note: *When bit ICE is set to 1 in 8TCSR1 and 8TCSR3, the CMFB flag is not set when 8TCNT0 = TCORB0 or 8TCNT2 = TCORB2.

Bit 6—Compare Match Flag A (CMFA): Status flag that indicates the occurrence of a TCORA compare match.

Bit 6 CMFA	Description	
0	[Clearing condition] Read CMFA when CMFA = 1, then write 0 in CMFA	(Initial value)
1	[Setting condition] 8TCNT = TCORA	

Bit 5—Timer Overflow Flag (OVF): Status flag that indicates that the 8TCNT has overflowed from H'FF to H'00.

Bit 5 OVF	Description	
0	[Clearing condition] Read OVF when OVF = 1, then write 0 in OVF	(Initial value)
1	[Setting condition] 8TCNT overflows from H'FF to H'00	

Bit 4—A/D Trigger Enable (ADTE) (In 8TCSR0): In combination with TRGE in the A/D control register (ADCR), enables or disables A/D converter start requests by compare match A or an external trigger.

TRGE*	Bit 4 ADTE	Description
0	0	A/D converter start requests by compare match A or external trigger pin (ADTRG) input are disabled (Initial value)
	1	A/D converter start requests by compare match A or external trigger pin (ADTRG) input are disabled
1	0	A/D converter start requests by external trigger pin (ADTRG) input are enabled, and A/D converter start requests by compare match A are disabled
	1	A/D converter start requests by compare match A are enabled, and A/D converter start requests by external trigger pin (ADTRG) input are disabled

Note: * TRGE is bit 7 of the A/D control register (ADCR).

Bit 4—Reserved (In 8TCSR1): This bit is a reserved bit, but can be read and written.

Bit 4—Input Capture Enable (ICE) (In 8TCSR1 and 8TCSR3): Selects the function of TCORB1 and TCORB3.

Bit 4 ICE	Description
0	TCORB1 and TCORB3 are compare match registers (Initial value)
1	TCORB1 and TCORB3 are input capture registers

When bit ICE is set to 1 in 8TCSR1 or 8TCSR3, the operation of the TCORA and TCORB registers in channels 0 to 3 is as shown in the tables below.

Table 10.3 Operation of Channels 0 and 1 when Bit ICE is Set to 1 in 8TCSR1 Register

Register	Register Function	Status Flag Change	Timer Output Capture Input	Interrupt Request
TCORA0	Compare match operation	CMFA changed from 0 to 1 in 8TCSR0 by compare match	TMO ₀ output controllable	CMIA0 interrupt request generated by compare match
TCORB0	Compare match operation	CMFB not changed from 0 to 1 in 8TCSR0 by compare match	No output from TMO ₀	CMIB0 interrupt request not generated by compare match
TCORA1	Compare match operation	CMFA changed from 0 to 1 in 8TCSR1 by compare match	TMIO ₁ is dedicated input capture pin	CMIA1 interrupt request generated by compare match
TCORB1	Input capture operation	CMFB changed from 0 to 1 in 8TCSR1 by input capture	TMIO ₁ is dedicated input capture pin	CMIB1 interrupt request generated by input capture

Table 10.4 Operation of Channels 2 and 3 when Bit ICE is Set to 1 in 8TCSR3 Register

Register	Register Function	Status Flag Change	Timer Output Capture Input	Interrupt Request
TCORA2	Compare match operation	CMFA changed from 0 to 1 in 8TCSR2 by compare match	TMO ₂ output controllable	CMIA2 interrupt request generated by compare match
TCORB2	Compare match operation	CMFB not changed from 0 to 1 in 8TCSR2 by compare match	No output from TMO ₂	CMIB2 interrupt request not generated by compare match
TCORA3	Compare match operation	CMFA changed from 0 to 1 in 8TCSR3 by compare match	TMIO ₃ is dedicated input capture pin	CMIA3 interrupt request generated by compare match
TCORB3	Input capture operation	CMFB changed from 0 to 1 in 8TCSR3 by input capture	TMIO ₃ is dedicated input capture pin	CMIB3 interrupt request generated by input capture

Bits 3 and 2—Output/Input Capture Edge Select B3 and B2 (OIS3, OIS2): In combination with the ICE bit in 8TCSR1 (8TCSR3), these bits select the compare match B output level or the input capture input detected edge.

The function of TCORB1 (TCORB3) depends on the setting of bit 4 of 8TCSR1 (8TCSR3).

ICE Bit in 8TCSR1 (8TCSR3)	Bit 3 OIS3	Bit 2 OIS2	Description
0	0	0	No change when compare match B occurs (Initial value)
		1	0 is output when compare match B occurs
	1	0	1 is output when compare match B occurs
		1	Output is inverted when compare match B occurs (toggle output)
1	0	0	TCORB input capture on rising edge
		1	TCORB input capture on falling edge
	1	0	TCORB input capture on both rising and falling edges
		1	

- When the compare match register function is used, the timer output priority order is: toggle output > 1 output > 0 output.
- If compare match A and B occur simultaneously, the output changes in accordance with the higher-priority compare match.
- When bits OIS3, OIS2, OS1, and OS0 are all cleared to 0, timer output is disabled.

Bits 1 and 0—Output Select A1 and A0 (OS1, OS0): These bits select the compare match A output level.

Bit 1 OS1	Bit 0 OS0	Description
0	0	No change when compare match A occurs (Initial value)
	1	0 is output when compare match A occurs
1	0	1 is output when compare match A occurs
	1	Output is inverted when compare match A occurs (toggle output)

- When the compare match register function is used, the timer output priority order is: toggle output > 1 output > 0 output.
- If compare match A and B occur simultaneously, the output changes in accordance with the higher-priority compare match.
- When bits OIS3, OIS2, OS1, and OS0 are all cleared to 0, timer output is disabled.

10.3 CPU Interface

10.3.1 8-Bit Registers

8TCNT, TCORA, TCORB, 8TCR, and 8TCSR are 8-bit registers. These registers are connected to the CPU by an internal 16-bit data bus and can be read and written a word at a time or a byte at a time.

Figures 10.2 and 10.3 show the operation in word read and write accesses to 8TCNT.

Figures 10.4 to 10.7 show the operation in byte read and write accesses to 8TCNT0 and 8TCNT1.

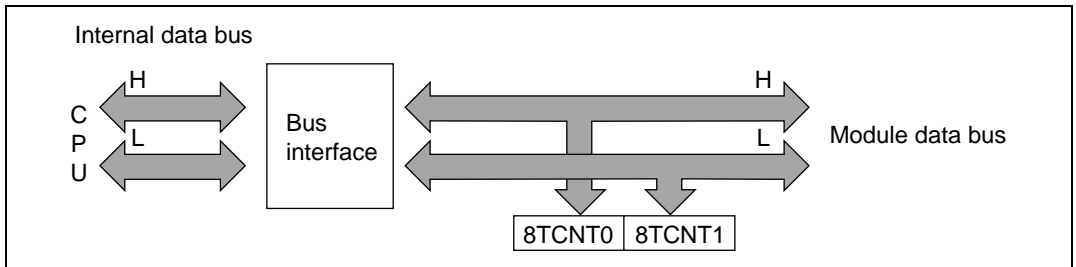

Figure 10.2 8TCNT Access Operation (CPU Writes to 8TCNT, Word)

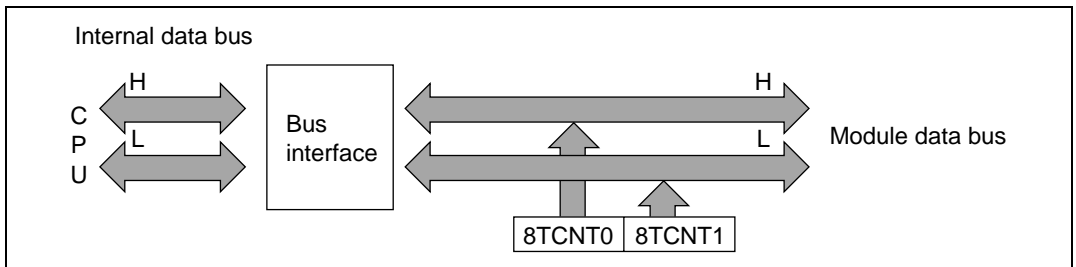

Figure 10.3 8TCNT Access Operation (CPU Reads 8TCNT, Word)

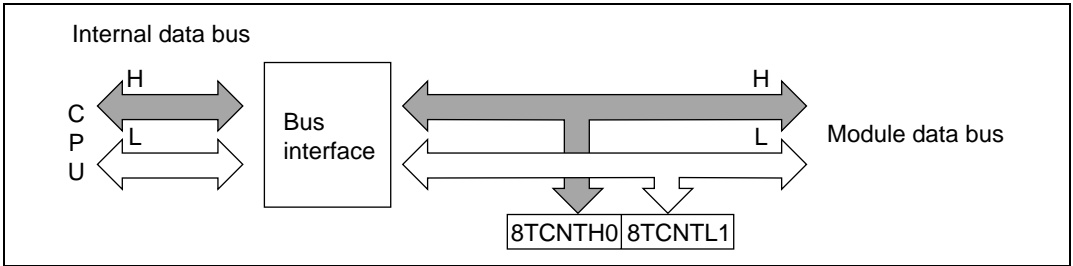

Figure 10.4 8TCNT0 Access Operation (CPU Writes to 8TCNT0, Upper Byte)

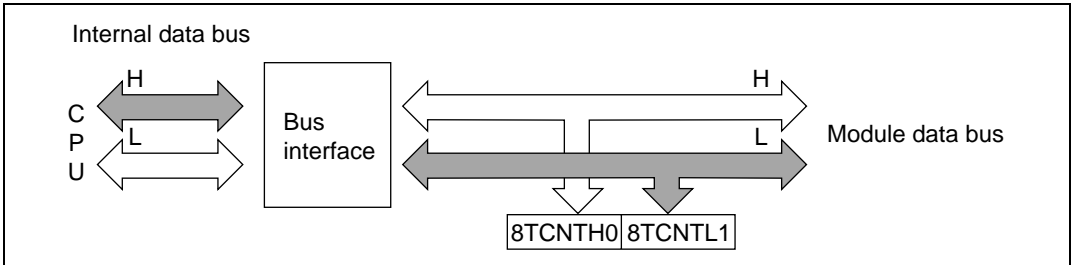

Figure 10.5 8TCNT1 Access Operation (CPU Writes to 8TCNT1, Lower Byte)

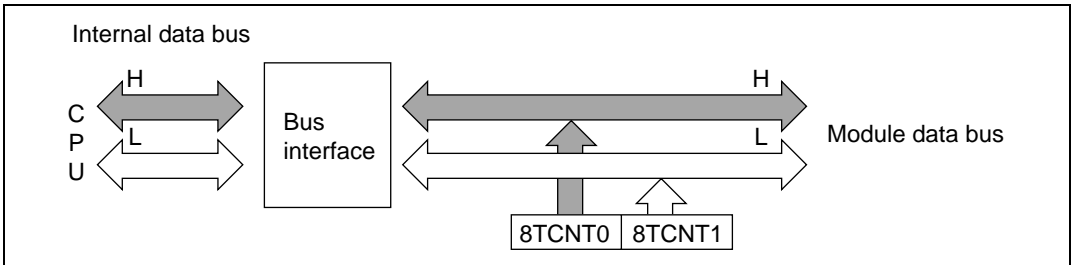

Figure 10.6 8TCNT0 Access Operation (CPU Reads 8TCNT0, Upper Byte)

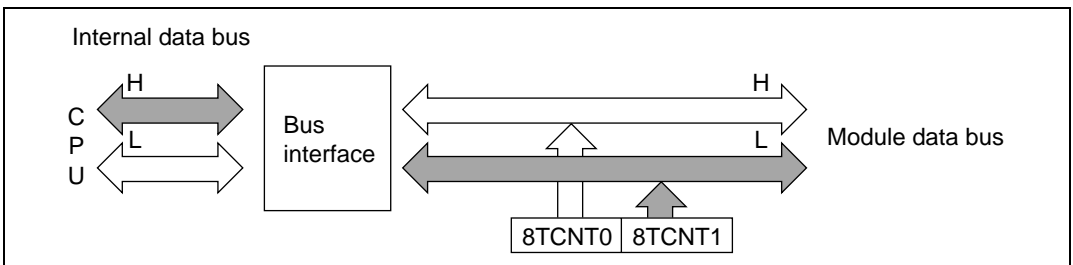

Figure 10.7 8TCNT1 Access Operation (CPU Reads 8TCNT1, Lower Byte)

10.4 Operation

10.4.1 8TCNT Count Timing

8TCNT is incremented by input clock pulses (either internal or external).

Internal Clock: Three different internal clock signals ($\phi/8$, $\phi/64$, or $\phi/8192$) divided from the system clock (ϕ) can be selected, by setting bits CKS2 to CKS0 in 8TCR. Figure 10.8 shows the count timing.

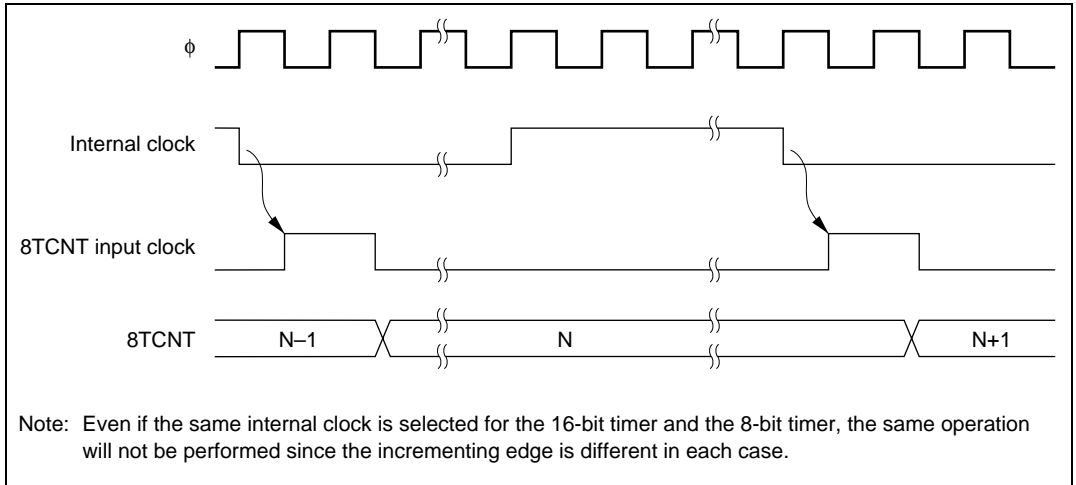

Figure 10.8 Count Timing for Internal Clock Input

External Clock: Three incrementation methods can be selected by setting bits CKS2 to CKS0 in 8TCR: on the rising edge, the falling edge, and both rising and falling edges.

The pulse width of the external clock signal must be at least 1.5 system clocks when a single edge is selected, and at least 2.5 system clocks when both edges are selected. Shorter pulses will not be counted correctly.

Figure 10.9 shows the timing for incrementation on both edges of the external clock signal.

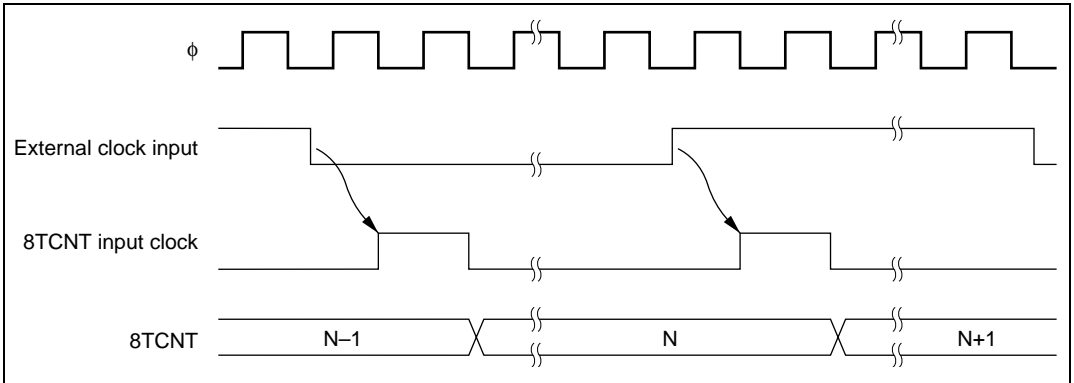

Figure 10.9 Count Timing for External Clock Input (Both-Edge Detection)

10.4.2 Compare Match Timing

Timer Output Timing: When compare match A or B occurs, the timer output is as specified by the OIS3, OIS2, OS1, and OS0 bits in 8TCSR (unchanged, 0 output, 1 output, or toggle output).

Figure 10.10 shows the timing when the output is set to toggle on compare match A.

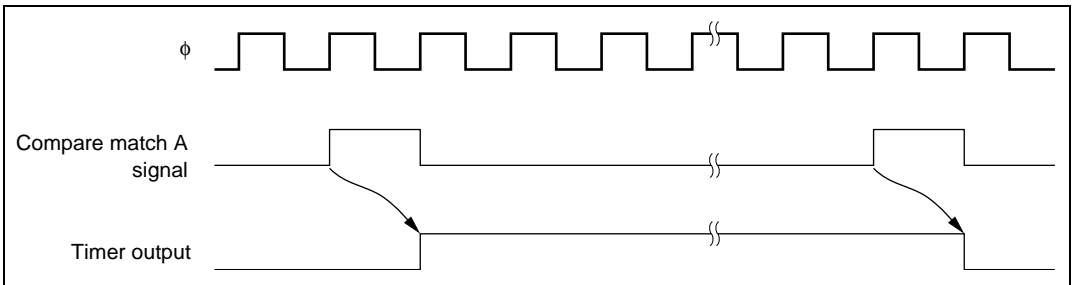

Figure 10.10 Timing of Timer Output

Clear by Compare Match: Depending on the setting of the CCLR1 and CCLR0 bits in 8TCR, 8TCNT can be cleared when compare match A or B occurs. Figure 10.11 shows the timing of this operation.

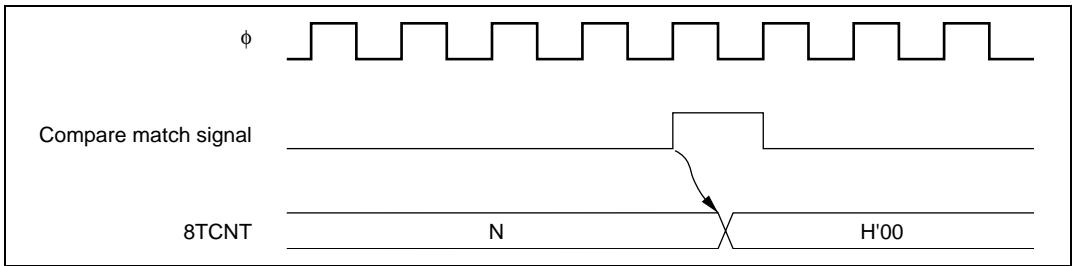

Figure 10.11 Timing of Clear by Compare Match

Clear by Input Capture: Depending on the setting of the CCLR1 and CCLR0 bits in 8TCR, 8TCNT can be cleared when input capture B occurs. Figure 10.12 shows the timing of this operation.

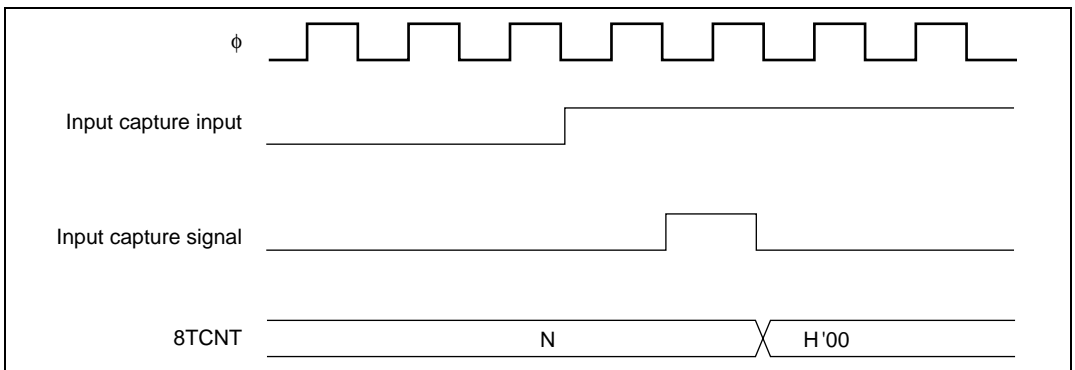

Figure 10.12 Timing of Clear by Input Capture

10.4.3 Input Capture Signal Timing

Input capture on the rising edge, falling edge, or both edges can be selected by settings in 8TCSR.

Figure 10.13 shows the timing when the rising edge is selected.

The pulse width of the input capture input signal must be at least 1.5 system clocks when a single edge is selected, and at least 2.5 system clocks when both edges are selected.

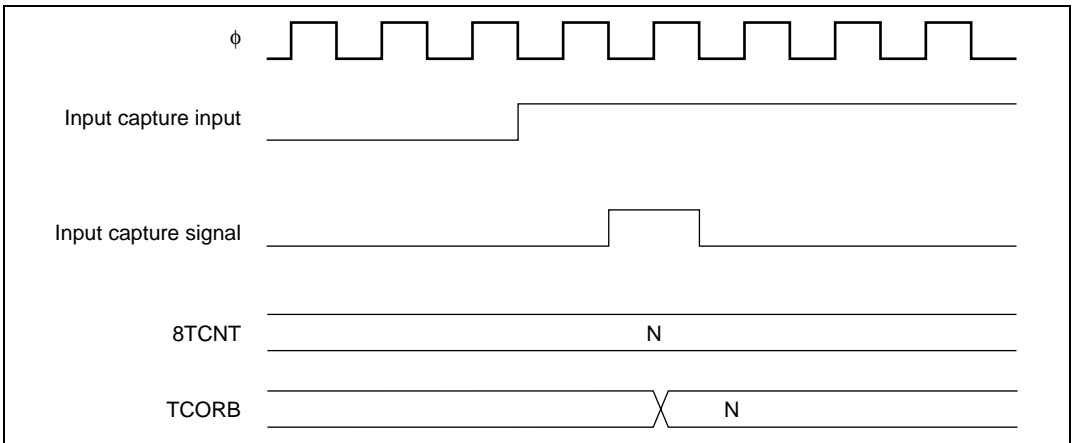

Figure 10.13 Timing of Input Capture Input Signal

10.4.4 Timing of Status Flag Setting

Timing of CMFA/CMFB Flag Setting when Compare Match Occurs: The CMFA and CMFB flags in 8TCSR are set to 1 by the compare match signal output when the TCORA or TCORB and 8TCNT values match. The compare match signal is generated in the last state of the match (when the matched 8TCNT count value is updated). Therefore, after the 8TCNT and TCORA or TCORB values match, the compare match signal is not generated until an incrementing clock pulse signal is generated. Figure 10.14 shows the timing in this case.

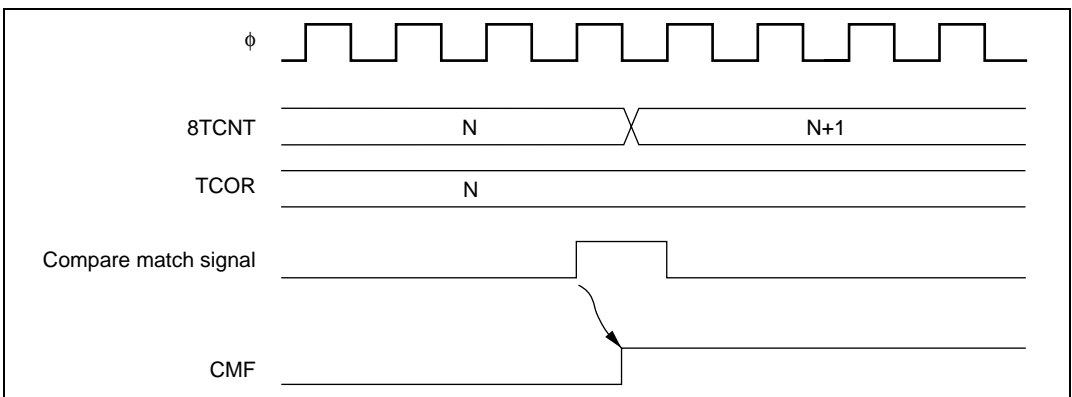

Figure 10.14 CMF Flag Setting Timing when Compare Match Occurs

Timing of CMFB Flag Setting when Input Capture Occurs: On generation of an input capture signal, the CMFB flag is set to 1 and at the same time the 8TCNT value is transferred to TCORB. Figure 10.15 shows the timing in this case.

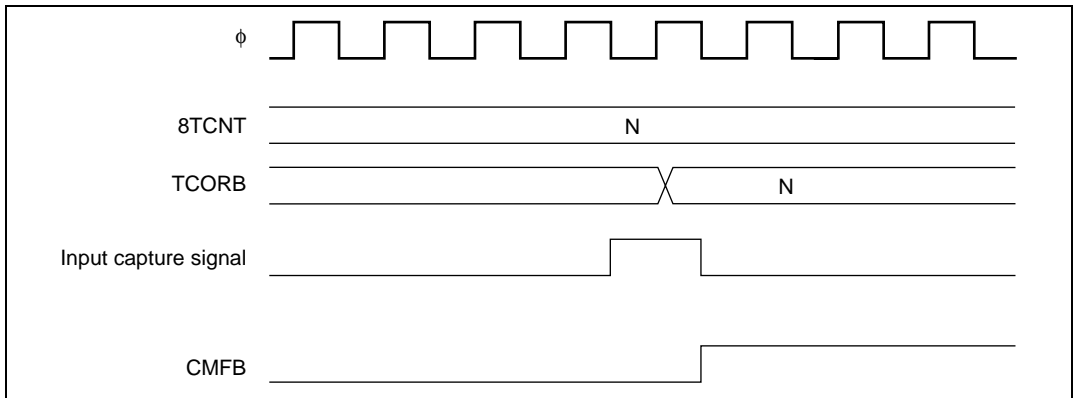

Figure 10.15 CMFB Flag Setting Timing when Input Capture Occurs

Timing of Overflow Flag (OVF) Setting: The OVF flag in 8TCSR is set to 1 by the overflow signal generated when 8TCNT overflows (from H'FF to H'00). Figure 10.16 shows the timing in this case.

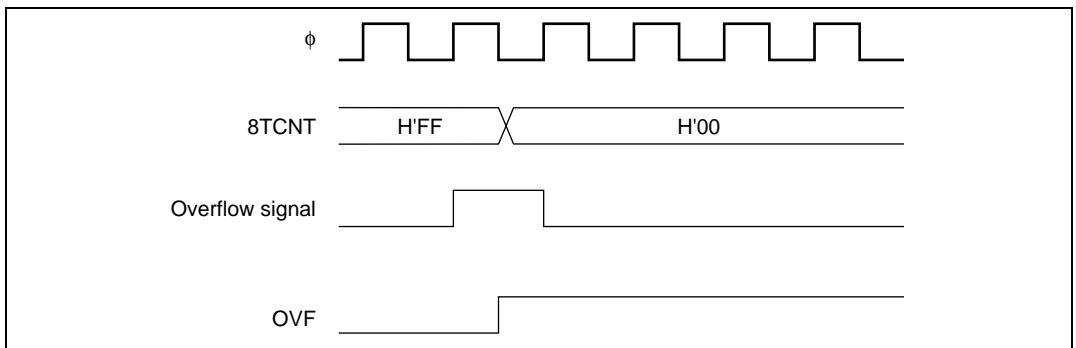

Figure 10.16 Timing of OVF Setting

10.4.5 Operation with Cascaded Connection

If bits CKS2 to CKS0 are set to (100) in either 8TCR0 or 8TCR1, the 8-bit timers of channels 0 and 1 are cascaded. With this configuration, the two timers can be used as a single 16-bit timer (16-bit timer mode), or channel 0 8-bit timer compare matches can be counted in channel 1 (compare match count mode). Similarly, if bits CKS2 to CKS0 are set to (100) in either 8TCR2

or 8TCR3, the 8-bit timers of channels 2 and 3 are cascaded. With this configuration, the two timers can be used as a single 16-bit timer (16-bit timer mode), or channel 2 8-bit timer compare matches can be counted in channel 3 (compare match count mode). In this case, the timer operates as below.

16-Bit Count Mode

- Channels 0 and 1:

When bits CKS2 to CKS0 are set to (100) in 8TCR0, the timer functions as a single 16-bit timer with channel 0 occupying the upper 8 bits and channel 1 occupying the lower 8 bits.

— Setting when Compare Match Occurs

- The CMFA or CMFB flag is set to 1 in 8TCSR0 when a 16-bit compare match occurs.
- The CMFA or CMFB flag is set to 1 in 8TCSR1 when a lower 8-bit compare match occurs.
- TMO₀ pin output control by bits OIS3, OIS2, OS1, and OS0 in 8TCSR0 is in accordance with the 16-bit compare match conditions.
- TMIO₁ pin output control by bits OIS3, OIS2, OS1, and OS0 in 8TCSR1 is in accordance with the lower 8-bit compare match conditions.

— Setting when Input Capture Occurs

- The CMFB flag is set to 1 in 8TCSR0 and 8TCSR1 when the ICE bit is 1 in TCSR1 and input capture occurs.
- TMIO₁ pin input capture input signal edge detection is selected by bits OIS3 and OIS2 in 8TCSR0.

— Counter Clear Specification

- If counter clear on compare match or input capture has been selected by the CCLR1 and CCLR0 bits in 8TCR0, the 16-bit counter (both 8TCNT0 and 8TCNT1) is cleared.
- The settings of the CCLR1 and CCLR0 bits in 8TCR1 are ignored. The lower 8 bits cannot be cleared independently.

— OVF Flag Operation

- The OVF flag is set to 1 in 8TCSR0 when the 16-bit counter (8TCNT0 and 8TCNT1) overflows (from H'FFFF to H'0000).
- The OVF flag is set to 1 in 8TCSR1 when the 8-bit counter (8TCNT1) overflows (from H'FF to H'00).

- Channels 2 and 3:

When bits CKS2 to CKS0 are set to (100) in 8TCR2, the timer functions as a single 16-bit timer with channel 2 occupying the upper 8 bits and channel 3 occupying the lower 8 bits.

- Setting when Compare Match Occurs

- The CMFA or CMFB flag is set to 1 in 8TCSR2 when a 16-bit compare match occurs.
- The CMFA or CMFB flag is set to 1 in 8TCSR3 when a lower 8-bit compare match occurs.
- TMO₂ pin output control by bits OIS3, OIS2, OS1, and OS0 in 8TCSR2 is in accordance with the 16-bit compare match conditions.
- TMIO₃ pin output control by bits OIS3, OIS2, OS1, and OS0 in 8TCSR3 is in accordance with the lower 8-bit compare match conditions.

- Setting when Input Capture Occurs

- The CMFB flag is set to 1 in 8TCSR2 and 8TCSR3 when the ICE bit is 1 in TCSR3 and input capture occurs.
- TMIO₃ pin input capture input signal edge detection is selected by bits OIS3 and OIS2 in 8TCSR2.

- Counter Clear Specification

- If counter clear on compare match has been selected by the CCLR1 and CCLR0 bits in 8TCR2, the 16-bit counter (both 8TCNT2 and 8TCNT3) is cleared.
- The settings of the CCLR1 and CCLR0 bits in 8TCR3 are ignored. The lower 8 bits cannot be cleared independently.

- OVF Flag Operation

- The OVF flag is set to 1 in 8TCSR2 when the 16-bit counter (8TCNT2 and 8TCNT3) overflows (from H'FFFF to H'0000).
- The OVF flag is set to 1 in 8TCSR3 when the 8-bit counter (8TCNT3) overflows (from H'FF to H'00).

Compare Match Count Mode

- Channels 0 and 1:

When bits CKS2 to CKS0 are set to (100) in 8TCR1, 8TCNT1 counts channel 0 compare match A events.

CMF flag setting, interrupt generation, TMO pin output, counter clearing, and so on, is in accordance with the settings for each channel.

Note: When bit ICE = 1 in 8TCSR1, the compare match register function of TCORB0 in channel 0 cannot be used.

- Channels 2 and 3:

When bits CKS2 to CKS0 are set to (100) in 8TCR3, 8TCNT3 counts channel 2 compare match A events.

CMF flag setting, interrupt generation, TMO pin output, counter clearing, and so on, is in accordance with the settings for each channel.

Note: When bit ICE = 1 in 8TCSR3, the compare match register function of TCORB2 in channel 2 cannot be used.

Caution

Do not set 16-bit counter mode and compare match count mode simultaneously within the same group, as the 8TCNT input clock will not be generated and the counters will not operate.

10.4.6 Input Capture Setting

The 8TCNT value can be transferred to TCORB on detection of an input edge on the input capture/output compare pin (TMIO₁ or TMIO₃). Rising edge, falling edge, or both edge detection can be selected. In 16-bit count mode, 16-bit input capture can be used.

Setting Input Capture Operation in 8-Bit Timer Mode (Normal Operation)

- Channel 1:
 - Set TCORB1 as an 8-bit input capture register with the ICE bit in 8TCSR1.
 - Select rising edge, falling edge, or both edges as the input edge(s) for the input capture signal (TMIO₁) with bits OIS3 and OIS2 in 8TCSR1.
 - Select the input clock with bits CKS2 to CKS0 in 8TCR1, and start the 8TCNT count.
- Channel 3:
 - Set TCORB3 as an 8-bit input capture register with the ICE bit in 8TCSR3.
 - Select rising edge, falling edge, or both edges as the input edge(s) for the input capture signal (TMIO₃) with bits OIS3 and OIS2 in 8TCSR3.
 - Select the input clock with bits CKS2 to CKS0 in 8TCR3, and start the 8TCNT count.

Note: When TCORB1 in channel 1 is used for input capture, TCORB0 in channel 0 cannot be used as a compare match register.

Similarly, when TCORB3 in channel 3 is used for input capture, TCORB2 in channel 2 cannot be used as a compare match register.

Setting Input Capture Operation in 16-Bit Count Mode

- Channels 0 and 1:
 - In 16-bit count mode, TCORB0 and TCORB1 function as a 16-bit input capture register when the ICE bit is set to 1 in 8TCSR1.
 - Select rising edge, falling edge, or both edges as the input edge(s) for the input capture signal (TMIO₁) with bits OIS3 and OIS2 in 8TCSR0. (In 16-bit count mode, the settings of bits OIS3 and OIS2 in 8TCSR1 are ignored.)
 - Select the input clock with bits CKS2 to CKS0 in 8TCR1, and start the 8TCNT count.
- Channels 2 and 3:
 - In 16-bit count mode, TCORB2 and TCORB3 function as a 16-bit input capture register when the ICE bit is set to 1 in 8TCSR3.
 - Select rising edge, falling edge, or both edges as the input edge(s) for the input capture signal (TMIO₃) with bits OIS3 and OIS2 in 8TCSR2. (In 16-bit count mode, the settings of bits OIS3 and OIS2 in 8TCSR3 are ignored.)
 - Select the input clock with bits CKS2 to CKS0 in 8TCR3, and start the 8TCNT count.

10.5 Interrupt

10.5.1 Interrupt Sources

The 8-bit timer unit can generate three types of interrupt: compare match A and B (CMIA and CMIB) and overflow (TOVI). Table 10.5 shows the interrupt sources and their priority order. Each interrupt source is enabled or disabled by the corresponding interrupt enable bit in 8TCR. A separate interrupt request signal is sent to the interrupt controller by each interrupt source.

Table 10.5 Types of 8-Bit Timer Interrupt Sources and Priority Order

Interrupt Source	Description	Priority
CMIA	Interrupt by CMFA	High
CMIB	Interrupt by CMFB	↕
TOVI	Interrupt by OVF	Low

For compare match interrupts CMIA1/CMIB1 and CMIA3/CMIB3 and the overflow interrupts (TOVI0/TOVI1 and TOVI2/TOVI3), one vector is shared by two interrupts.

Table 10.6 lists the interrupt sources.

Table 10.6 8-Bit Timer Interrupt Sources

Channel	Interrupt Source	Description
0	CMIA0	TCORA0 compare match
	CMIB0	TCORB0 compare match/input capture
1	CMIA1/CMIB1	TCORA1 compare match, or TCORB1 compare match/input capture
0, 1	TOVI0/TOVI1	Counter 0 or counter 1 overflow
2	CMIA2	TCORA2 compare match
	CMIB2	TCORB2 compare match/input capture
3	CMIA3/CMIB3	TCORA3 compare match, or TCORB3 compare match/input capture
2, 3	TOVI2/TOVI3	Counter 2 or counter 3 overflow

10.5.2 A/D Converter Activation

The A/D converter can only be activated by channel 0 compare match A.

If the ADTE bit setting is 1 when the CMFA flag in 8TCSR0 is set to 1 by generation of channel 0 compare match A, an A/D conversion start request will be issued to the A/D converter. If the TRGE bit in ADCR is 1 at this time, the A/D converter will be started. If the ADTE bit in 8TCSR0 is 1, A/D converter external trigger pin ($\overline{\text{ADTRG}}$) input is disabled.

10.6 8-Bit Timer Application Example

Figure 10.17 shows how the 8-bit timer module can be used to output pulses with any desired duty cycle. The settings for this example are as follows:

- Clear the CCLR1 bit to 0 and set the CCLR0 bit to 1 in 8TCR so that 8TCNT is cleared by a TCORA compare match.
- Set bits OIS3, OIS2, OS1, and OS0 to (0110) in 8TCSR so that 1 is output on a TCORA compare match and 0 is output on a TCORB compare match.

The above settings enable a waveform with the cycle determined by TCORA and the pulse width detected by TCORB to be output without software intervention.

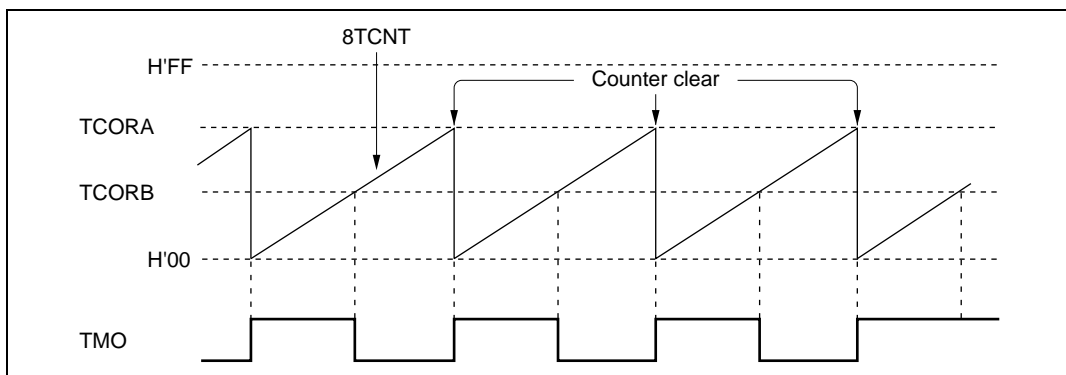

Figure 10.17 Example of Pulse Output

10.7 Usage Notes

Note that the following kinds of contention can occur in 8-bit timer operation.

10.7.1 Contention between 8TCNT Write and Clear

If a timer counter clear signal occurs in the T_3 state of a 8TCNT write cycle, clearing of the counter takes priority and the write is not performed. Figure 10.18 shows the timing in this case.

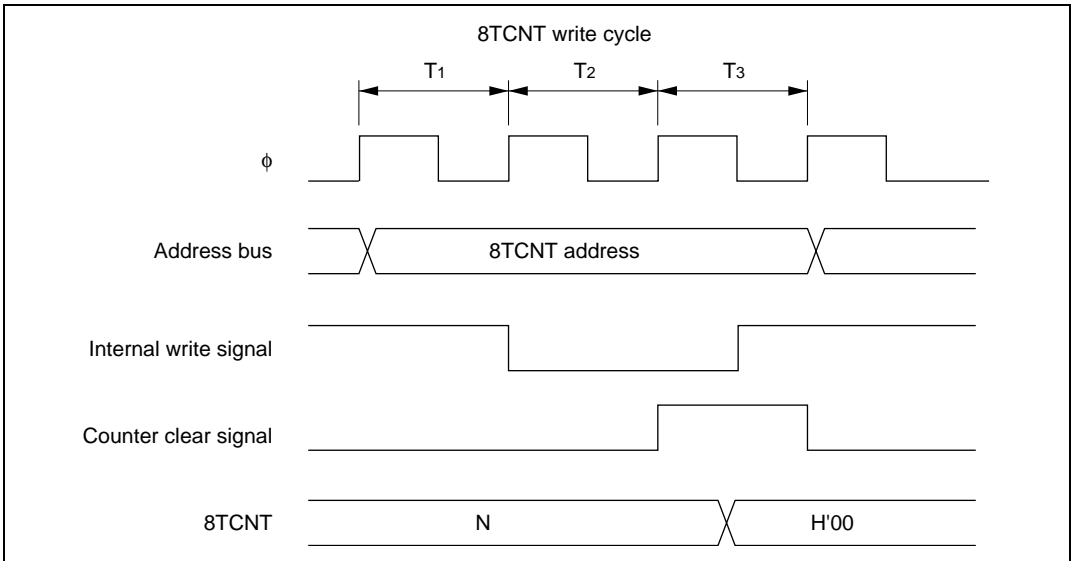

Figure 10.18 Contention between 8TCNT Write and Clear

10.7.2 Contention between 8TCNT Write and Increment

If an increment pulse occurs in the T_3 state of a 8TCNT write cycle, writing takes priority and 8TCNT is not incremented. Figure 10.19 shows the timing in this case.

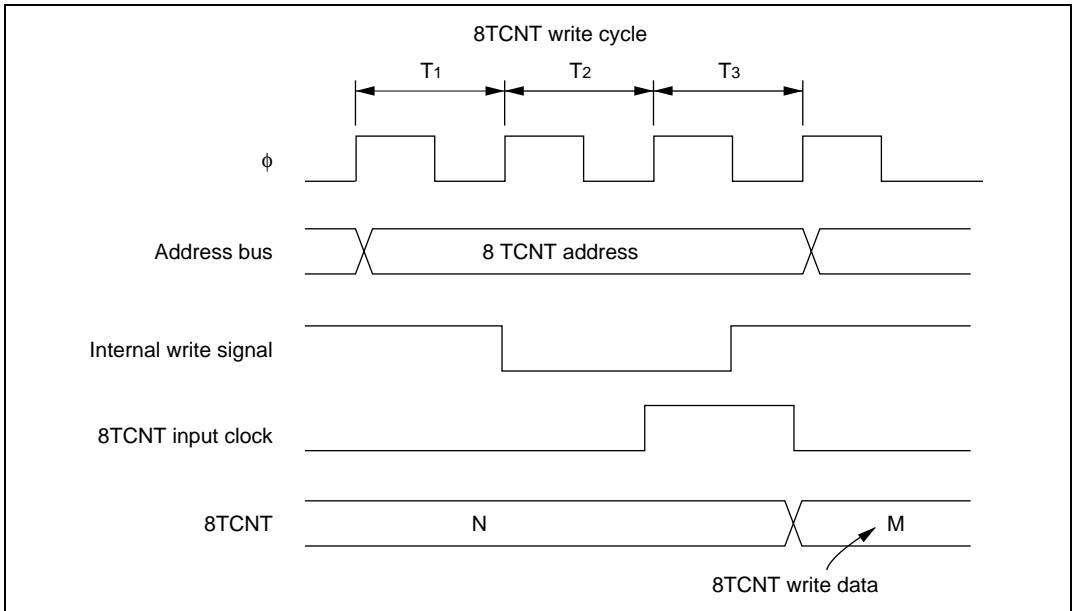

Figure 10.19 Contention between 8TCNT Write and Increment

10.7.3 Contention between TCOR Write and Compare Match

If a compare match occurs in the T_3 state of a TCOR write cycle, writing takes priority and the compare match signal is inhibited. Figure 10.20 shows the timing in this case.

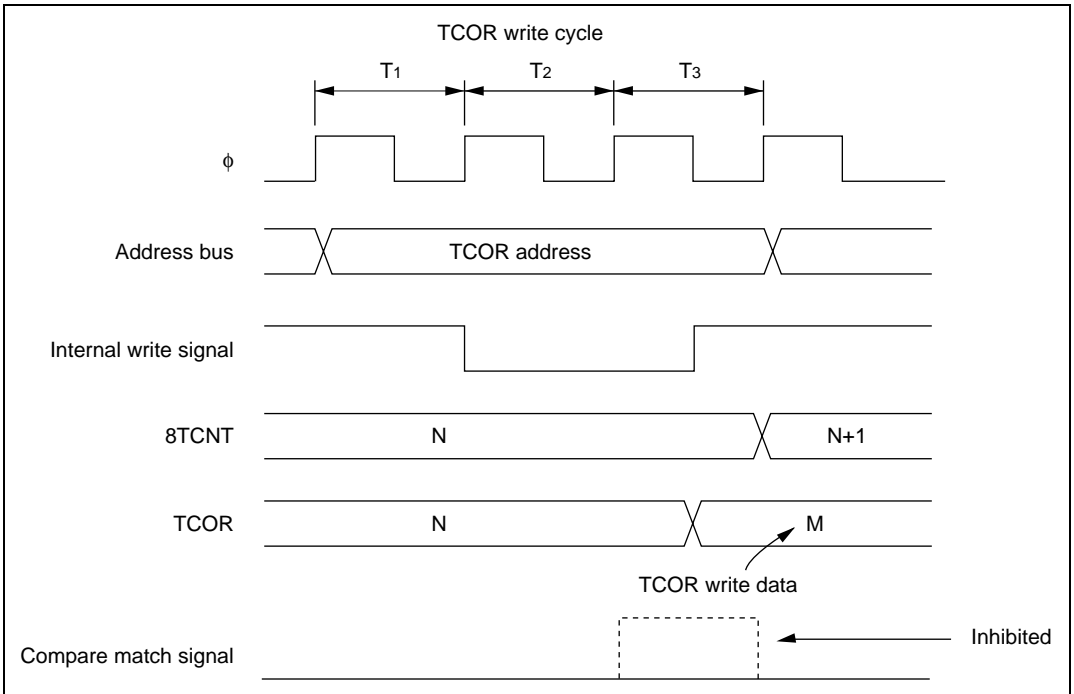

Figure 10.20 Contention between TCOR Write and Compare Match

10.7.4 Contention between TCOR Read and Input Capture

If an input capture signal occurs in the T_3 state of a TCOR read cycle, the value before input capture is read. Figure 10.21 shows the timing in this case.

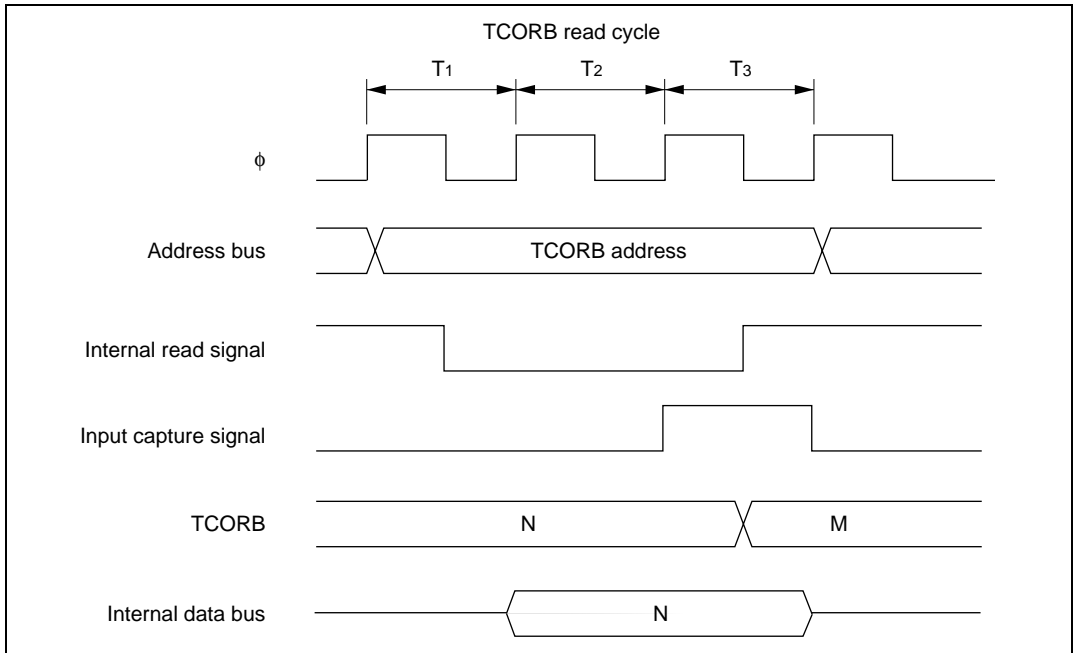

Figure 10.21 Contention between TCOR Read and Input Capture

10.7.5 Contention between Counter Clearing by Input Capture and Counter Increment

If an input capture signal and counter increment signal occur simultaneously, counter clearing by the input capture signal takes priority and the counter is not incremented. The value before the counter is cleared is transferred to TCORB. Figure 10.22 shows the timing in this case.

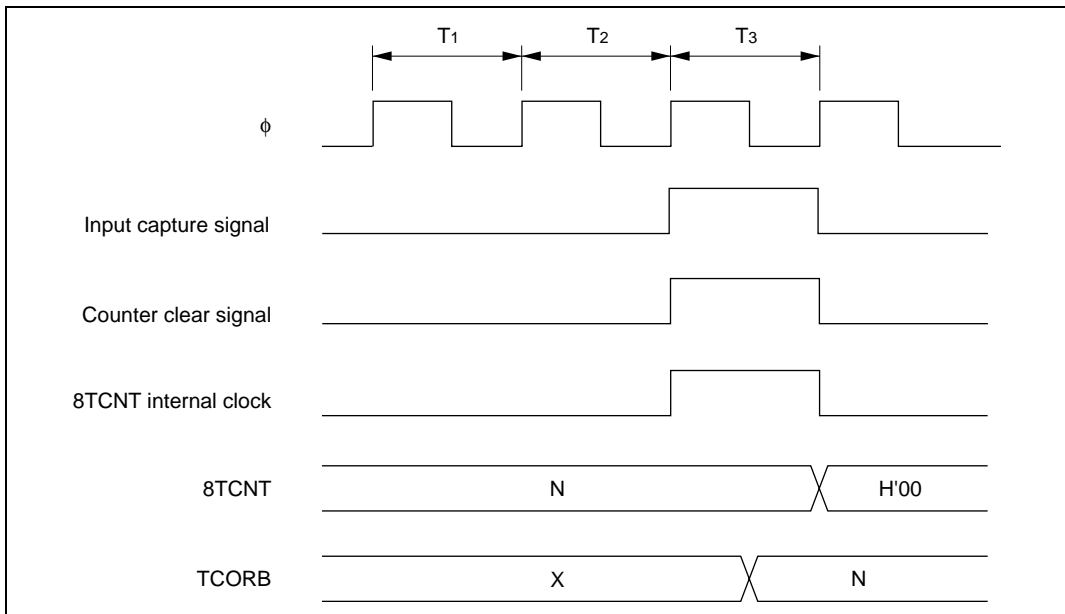

Figure 10.22 Contention between Counter Clearing by Input Capture and Counter Increment

10.7.6 Contention between TCOR Write and Input Capture

If an input capture signal occurs in the T_3 state of a TCOR write cycle, input capture takes priority and the write to TCOR is not performed. Figure 10.23 shows the timing in this case.

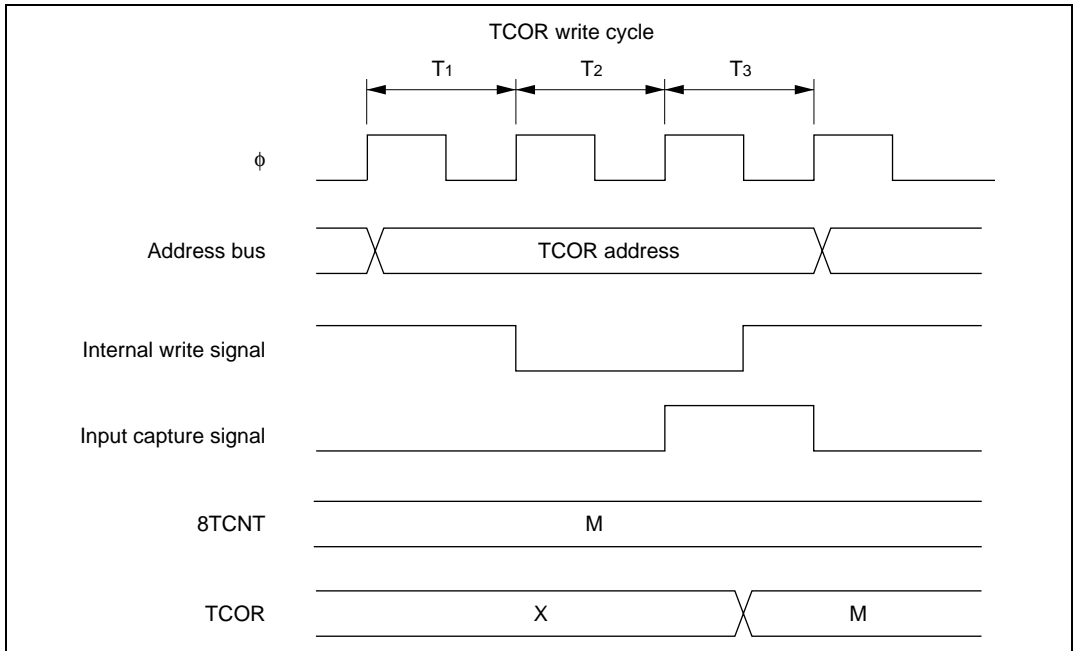

Figure 10.23 Contention between TCOR Write and Input Capture

10.7.7 Contention between 8TCNT Byte Write and Increment in 16-Bit Count Mode (Cascaded Connection)

If an increment pulse occurs in the T_3 state of an 8TCNT byte write cycle in 16-bit count mode, the counter write takes priority and the byte data for which the write was performed is not incremented. The byte data for which a write was not performed is incremented. Figure 10.24 shows the timing when an increment pulse occurs in the T_2 state of a byte write to 8TCNT (upper byte). If an increment pulse occurs in the T_2 state, on the other hand, the increment takes priority.

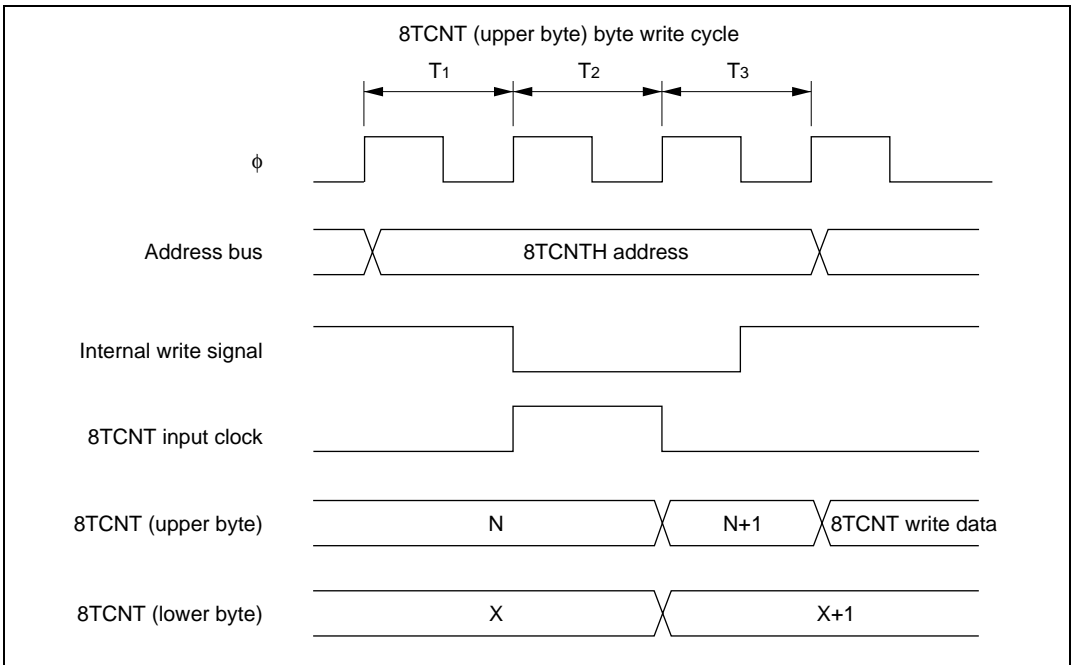

Figure 10.24 Contention between 8TCNT Byte Write and Increment in 16-Bit Count Mode

10.7.8 Contention between Compare Matches A and B

If compare matches A and B occur at the same time, the 8-bit timer operates according to the relative priority of the output states set for compare match A and compare match B, as shown in Table 10.7.

Table 10.7 Timer Output Priority Order

Output Setting	Priority
Toggle output	High
1 output	↑
0 output	↓
No change	Low

10.7.9 8TCNT Operation and Internal Clock Source Switchover

Switching internal clock sources may cause 8TCNT to increment, depending on the switchover timing. Table 10.8 shows the relation between the time of the switchover (by writing to bits CKS1 and CKS0) and the operation of 8TCNT.

The 8TCNT input clock is generated from the internal clock source by detecting the rising edge of the internal clock. If a switchover is made from a low clock source to a high clock source, as in case No. 3 in Table 10.8, the switchover will be regarded as a falling edge, a 8TCNT clock pulse will be generated, and 8TCNT will be incremented.

8TCNT may also be incremented when switching between internal and external clocks.

Table 10.8 Internal Clock Switchover and 8TCNT Operation

No.	CKS1 and CKS0 Write Timing	8TCNT Operation
1	High → high switchover* ¹	<p>Old clock source</p> <p>New clock source</p> <p>8TCNT clock</p> <p>8TCNT</p> <p>CKS bits rewritten</p>
2	High → low switchover* ²	<p>Old clock source</p> <p>New clock source</p> <p>8TCNT clock</p> <p>8TCNT</p> <p>CKS bits rewritten</p>
3	Low → high switchover* ³	<p>Old clock source</p> <p>New clock source</p> <p>8TCNT clock</p> <p>8TCNT</p> <p>CKS bits rewritten</p>

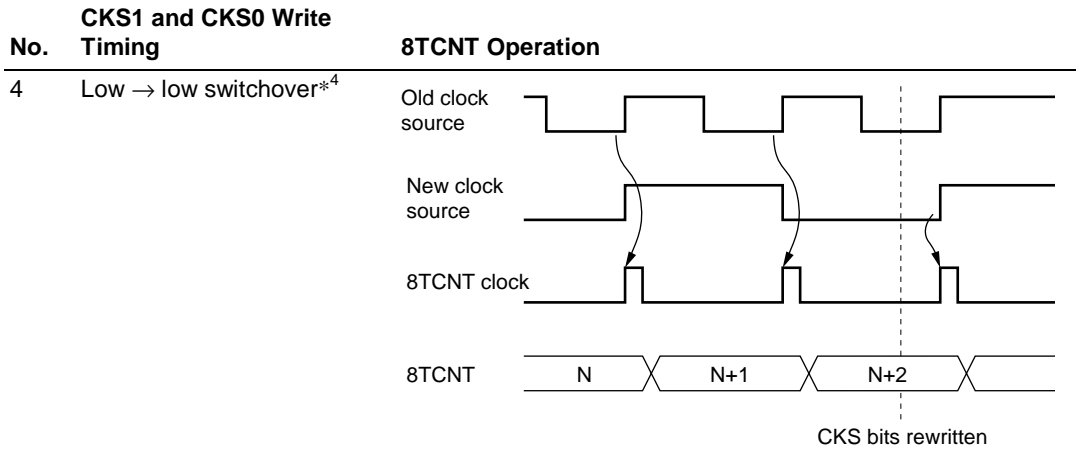

- Notes:
1. Including switchovers from the high level to the halted state, and from the halted state to the high level.
 2. Including switchover from the halted state to the low level.
 3. Including switchover from the low level to the halted state.
 4. The switchover is regarded as a rising edge, causing 8TCNT to increment.

Section 11 Programmable Timing Pattern Controller (TPC)

11.1 Overview

The H8/3068F has a built-in programmable timing pattern controller (TPC) that provides pulse outputs by using the 16-bit timer as a time base. The TPC pulse outputs are divided into 4-bit groups (group 3 to group 0) that can operate simultaneously and independently.

11.1.1 Features

TPC features are listed below.

- 16-bit output data
Maximum 16-bit data can be output. TPC output can be enabled on a bit-by-bit basis.
- Four output groups
Output trigger signals can be selected in 4-bit groups to provide up to four different 4-bit outputs.
- Selectable output trigger signals
Output trigger signals can be selected for each group from the compare match signals of three 16-bit timer channels.
- Non-overlap mode
A non-overlap margin can be provided between pulse outputs.
- Can operate together with the DMA controller (DMAC)
The compare-match signals selected as trigger signals can activate the DMAC for sequential output of data without CPU intervention.

11.1.2 Block Diagram

Figure 11.1 shows a block diagram of the TPC.

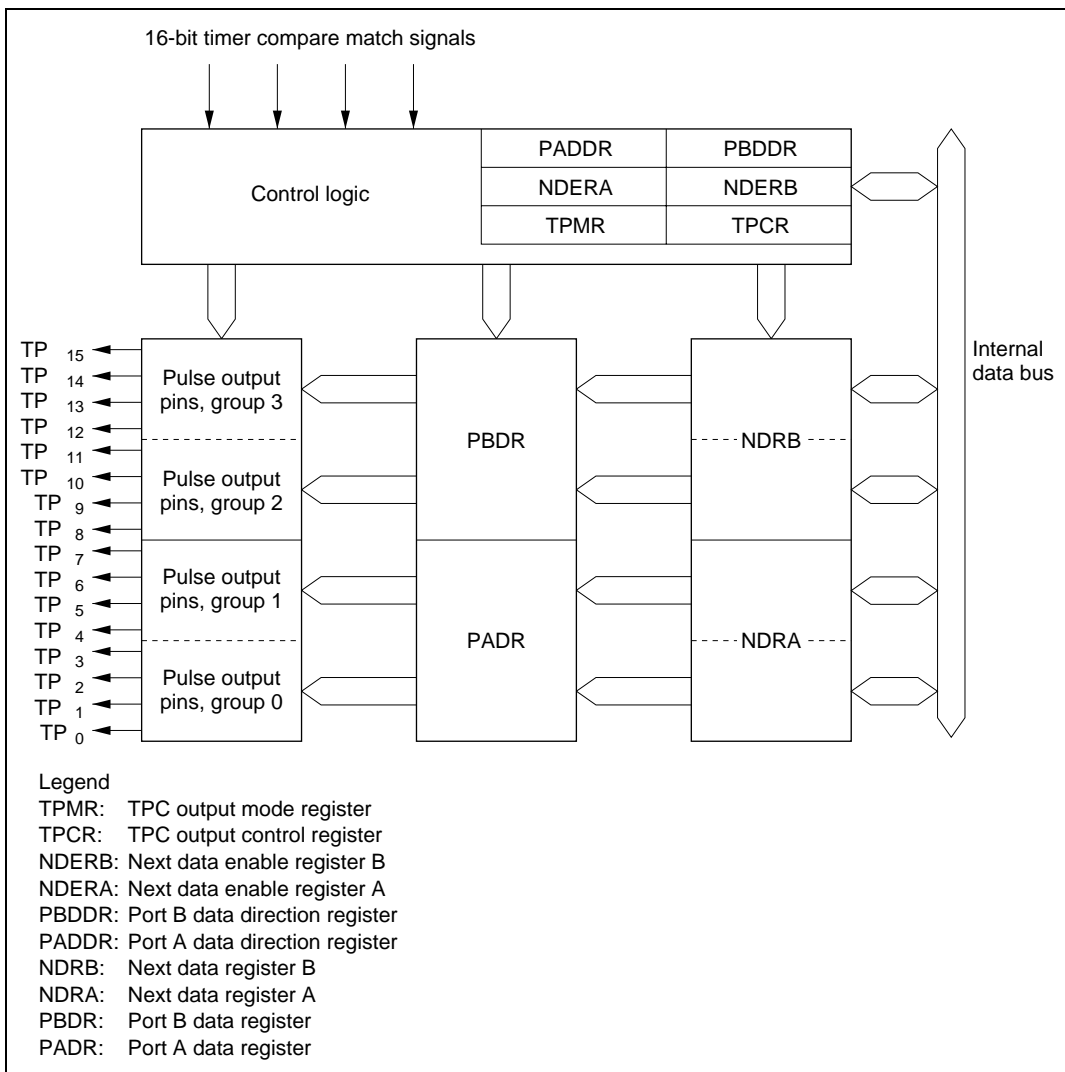

Figure 11.1 TPC Block Diagram

11.1.3 TPC Pins

Table 11.1 summarizes the TPC output pins.

Table 11.1 TPC Pins

Name	Symbol	I/O	Function
TPC output 0	TP ₀	Output	Group 0 pulse output
TPC output 1	TP ₁	Output	
TPC output 2	TP ₂	Output	
TPC output 3	TP ₃	Output	Group 1 pulse output
TPC output 4	TP ₄	Output	
TPC output 5	TP ₅	Output	
TPC output 6	TP ₆	Output	Group 2 pulse output
TPC output 7	TP ₇	Output	
TPC output 8	TP ₈	Output	
TPC output 9	TP ₉	Output	Group 3 pulse output
TPC output 10	TP ₁₀	Output	
TPC output 11	TP ₁₁	Output	
TPC output 12	TP ₁₂	Output	
TPC output 13	TP ₁₃	Output	
TPC output 14	TP ₁₄	Output	
TPC output 15	TP ₁₅	Output	

11.1.4 Registers

Table 11.2 summarizes the TPC registers.

Table 11.2 TPC Registers

Address* ¹	Name	Abbreviation	R/W	Function
H'EE009	Port A data direction register	PADDR	W	H'00
H'FFFD9	Port A data register	PADR	R/(W)* ²	H'00
H'EE00A	Port B data direction register	PBDDR	W	H'00
H'FFFDA	Port B data register	PBDR	R/(W)* ²	H'00
H'FFFA0	TPC output mode register	TPMR	R/W	H'F0
H'FFFA1	TPC output control register	TPCR	R/W	H'FF
H'FFFA2	Next data enable register B	NDERB	R/W	H'00
H'FFFA3	Next data enable register A	NDERA	R/W	H'00
H'FFFA5/ H'FFFA7* ³	Next data register A	NDRA	R/W	H'00
H'FFFA4/ H'FFFA6* ³	Next data register B	NDRB	R/W	H'00

Notes: 1. Lower 20 bits of the address in advanced mode.

2. Bits used for TPC output cannot be written.

3. The NDRA address is H'FFFA5 when the same output trigger is selected for TPC output groups 0 and 1 by settings in TPCR. When the output triggers are different, the NDRA address is H'FFFA7 for group 0 and H'FFFA5 for group 1. Similarly, the address of NDRB is H'FFFA4 when the same output trigger is selected for TPC output groups 2 and 3 by settings in TPCR. When the output triggers are different, the NDRB address is H'FFFA6 for group 2 and H'FFFA4 for group 3.

11.2 Register Descriptions

11.2.1 Port A Data Direction Register (PADDR)

PADDR is an 8-bit write-only register that selects input or output for each pin in port A.

Bit	7	6	5	4	3	2	1	0
	PA ₇ DDR	PA ₆ DDR	PA ₅ DDR	PA ₄ DDR	PA ₃ DDR	PA ₂ DDR	PA ₁ DDR	PA ₀ DDR
Initial value	0	0	0	0	0	0	0	0
Read/Write	W	W	W	W	W	W	W	W

Port A data direction 7 to 0

These bits select input or output for port A pins

Port A is multiplexed with pins TP₇ to TP₀. Bits corresponding to pins used for TPC output must be set to 1. For further information about PADDR, see section 8.11, Port A.

11.2.2 Port A Data Register (PADR)

PADR is an 8-bit readable/writable register that stores TPC output data for groups 0 and 1, when these TPC output groups are used.

Bit	7	6	5	4	3	2	1	0
	PA ₇	PA ₆	PA ₅	PA ₄	PA ₃	PA ₂	PA ₁	PA ₀
Initial value	0	0	0	0	0	0	0	0
Read/Write	R/(W)*	R/(W)*	R/(W)*	R/(W)*	R/(W)*	R/(W)*	R/(W)*	R/(W)*

Port A data 7 to 0

These bits store output data for TPC output groups 0 and 1

Note: * Bits selected for TPC output by NDERA settings become read-only bits.

For further information about PADR, see section 8.11, Port A.

11.2.3 Port B Data Direction Register (PBDDR)

PBDDR is an 8-bit write-only register that selects input or output for each pin in port B.

Bit	7	6	5	4	3	2	1	0
	PB ₇ DDR	PB ₆ DDR	PB ₅ DDR	PB ₄ DDR	PB ₃ DDR	PB ₂ DDR	PB ₁ DDR	PB ₀ DDR
Initial value	0	0	0	0	0	0	0	0
Read/Write	W	W	W	W	W	W	W	W

Port B direction 7 to 0

These bits select input or output for port B pins

Port B is multiplexed with pins TP₁₅ to TP₈. Bits corresponding to pins used for TPC output must be set to 1. For further information about PBDDR, see section 8.12, Port B.

11.2.4 Port B Data Register (PBDR)

PBDR is an 8-bit readable/writable register that stores TPC output data for groups 2 and 3, when these TPC output groups are used.

Bit	7	6	5	4	3	2	1	0
	PB ₇	PB ₆	PB ₅	PB ₄	PB ₃	PB ₂	PB ₁	PB ₀
Initial value	0	0	0	0	0	0	0	0
Read/Write	R/(W)*	R/(W)*	R/(W)*	R/(W)*	R/(W)*	R/(W)*	R/(W)*	R/(W)*

Port B data 7 to 0

These bits store output data for TPC output groups 2 and 3

Note: * Bits selected for TPC output by NDERB settings become read-only bits.

For further information about PBDR, see section 8.12, Port B.

11.2.5 Next Data Register A (NDRA)

NDRA is an 8-bit readable/writable register that stores the next output data for TPC output groups 1 and 0 (pins TP₇ to TP₀). During TPC output, when an 16-bit timer compare match event specified in TPCR occurs, NDRA contents are transferred to the corresponding bits in PADR. The address of NDRA differs depending on whether TPC output groups 0 and 1 have the same output trigger or different output triggers.

NDRA is initialized to H'00 by a reset and in hardware standby mode. It is not initialized in software standby mode.

Same Trigger for TPC Output Groups 0 and 1: If TPC output groups 0 and 1 are triggered by the same compare match event, the NDRA address is H'FFFA5. The upper 4 bits belong to group 1 and the lower 4 bits to group 0. Address H'FFFA7 consists entirely of reserved bits that cannot be modified and always read 1.

Address H'FFFA5

Bit	7	6	5	4	3	2	1	0
	NDR7	NDR6	NDR5	NDR4	NDR3	NDR2	NDR1	NDR0
Initial value	0	0	0	0	0	0	0	0
Read/Write	R/W	R/W	R/W	R/W	R/W	R/W	R/W	R/W

Next data 7 to 4	Next data 3 to 0
These bits store the next output data for TPC output group 1	These bits store the next output data for TPC output group 0

Address H'FFFA7

Bit	7	6	5	4	3	2	1	0
	—	—	—	—	—	—	—	—
Initial value	1	1	1	1	1	1	1	1
Read/Write	—	—	—	—	—	—	—	—

Reserved bits

Different Triggers for TPC Output Groups 0 and 1: If TPC output groups 0 and 1 are triggered by different compare match events, the address of the upper 4 bits of NDRA (group 1) is H'FFFA5 and the address of the lower 4 bits (group 0) is H'FFFA7. Bits 3 to 0 of address H'FFFA5 and bits 7 to 4 of address H'FFFA7 are reserved bits that cannot be modified and always read 1.

Address H'FFFA5

Bit	7	6	5	4	3	2	1	0
	NDR7	NDR6	NDR5	NDR4	—	—	—	—
Initial value	0	0	0	0	1	1	1	1
Read/Write	R/W	R/W	R/W	R/W	—	—	—	—

Next data 7 to 4
Reserved bits

These bits store the next output data for TPC output group 1

Address H'FFFA7

Bit	7	6	5	4	3	2	1	0
	—	—	—	—	NDR3	NDR2	NDR1	NDR0
Initial value	1	1	1	1	0	0	0	0
Read/Write	—	—	—	—	R/W	R/W	R/W	R/W

Reserved bits
Next data 3 to 0

These bits store the next output data for TPC output group 0

11.2.6 Next Data Register B (NDRB)

NDRB is an 8-bit readable/writable register that stores the next output data for TPC output groups 3 and 2 (pins TP₁₅ to TP₈). During TPC output, when an 16-bit timer compare match event specified in TPCR occurs, NDRB contents are transferred to the corresponding bits in PBDR. The address of NDRB differs depending on whether TPC output groups 2 and 3 have the same output trigger or different output triggers.

NDRB is initialized to H'00 by a reset and in hardware standby mode. It is not initialized in software standby mode.

Same Trigger for TPC Output Groups 2 and 3: If TPC output groups 2 and 3 are triggered by the same compare match event, the NDRB address is H'FFFA4. The upper 4 bits belong to group 3 and the lower 4 bits to group 2. Address H'FFFA6 consists entirely of reserved bits that cannot be modified and always read 1.

Address H'FFFA4

Bit	7	6	5	4	3	2	1	0
	NDR15	NDR14	NDR13	NDR12	NDR11	NDR10	NDR9	NDR8
Initial value	0	0	0	0	0	0	0	0
Read/Write	R/W	R/W	R/W	R/W	R/W	R/W	R/W	R/W

Next data 15 to 12	Next data 11 to 8
These bits store the next output data for TPC output group 3	These bits store the next output data for TPC output group 2

Address H'FFFA6

Bit	7	6	5	4	3	2	1	0
	—	—	—	—	—	—	—	—
Initial value	1	1	1	1	1	1	1	1
Read/Write	—	—	—	—	—	—	—	—

Reserved bits

Different Triggers for TPC Output Groups 2 and 3: If TPC output groups 2 and 3 are triggered by different compare match events, the address of the upper 4 bits of NDRB (group 3) is H'FFFA4 and the address of the lower 4 bits (group 2) is H'FFFA6. Bits 3 to 0 of address H'FFFA4 and bits 7 to 4 of address H'FFFA6 are reserved bits that cannot be modified and always read 1.

Address H'FFFA4

Bit	7	6	5	4	3	2	1	0
	NDR15	NDR14	NDR13	NDR12	—	—	—	—
Initial value	0	0	0	0	1	1	1	1
Read/Write	R/W	R/W	R/W	R/W	—	—	—	—

Next data 15 to 12
Reserved bits

These bits store the next output data for TPC output group 3

Address H'FFFA6

Bit	7	6	5	4	3	2	1	0
	—	—	—	—	NDR11	NDR10	NDR9	NDR8
Initial value	1	1	1	1	0	0	0	0
Read/Write	—	—	—	—	R/W	R/W	R/W	R/W

Reserved bits
Next data 11 to 8

These bits store the next output data for TPC output group 2

11.2.7 Next Data Enable Register A (NDERA)

NDERA is an 8-bit readable/writable register that enables or disables TPC output groups 1 and 0 (TP₇ to TP₀) on a bit-by-bit basis.

Bit	7	6	5	4	3	2	1	0
	NDER7	NDER6	NDER5	NDER4	NDER3	NDER2	NDER1	NDER0
Initial value	0	0	0	0	0	0	0	0
Read/Write	R/W	R/W	R/W	R/W	R/W	R/W	R/W	R/W

Next data enable 7 to 0

These bits enable or disable
TPC output groups 1 and 0

If a bit is enabled for TPC output by NDERA, then when the 16-bit timer compare match event selected in the TPC output control register (TPCR) occurs, the NDRA value is automatically transferred to the corresponding PADR bit, updating the output value. If TPC output is disabled, the bit value is not transferred from NDRA to PADR and the output value does not change.

NDERA is initialized to H'00 by a reset and in hardware standby mode. It is not initialized in software standby mode.

Bits 7 to 0—Next Data Enable 7 to 0 (NDER7 to NDER0): These bits enable or disable TPC output groups 1 and 0 (TP₇ to TP₀) on a bit-by-bit basis.

Bits 7 to 0

NDER7 to NDER0

Description

0	TPC outputs TP ₇ to TP ₀ are disabled (NDR7 to NDR0 are not transferred to PA ₇ to PA ₀)	(Initial value)
1	TPC outputs TP ₇ to TP ₀ are enabled (NDR7 to NDR0 are transferred to PA ₇ to PA ₀)	

11.2.8 Next Data Enable Register B (NDERB)

NDERB is an 8-bit readable/writable register that enables or disables TPC output groups 3 and 2 (TP₁₅ to TP₈) on a bit-by-bit basis.

Bit	7	6	5	4	3	2	1	0
	NDER15	NDER14	NDER13	NDER12	NDER11	NDER10	NDER9	NDER8
Initial value	0	0	0	0	0	0	0	0
Read/Write	R/W	R/W	R/W	R/W	R/W	R/W	R/W	R/W

Next data enable 15 to 8

These bits enable or disable
TPC output groups 3 and 2

If a bit is enabled for TPC output by NDERB, then when the 16-bit timer compare match event selected in the TPC output control register (TPCR) occurs, the NDRB value is automatically transferred to the corresponding PBDR bit, updating the output value. If TPC output is disabled, the bit value is not transferred from NDRB to PBDR and the output value does not change.

NDERB is initialized to H'00 by a reset and in hardware standby mode. It is not initialized in software standby mode.

Bits 7 to 0—Next Data Enable 15 to 8 (NDER15 to NDER8): These bits enable or disable TPC output groups 3 and 2 (TP₁₅ to TP₈) on a bit-by-bit basis.

Bits 7 to 0

NDER15 to NDER8

Description

0	TPC outputs TP ₁₅ to TP ₈ are disabled (NDR15 to NDR8 are not transferred to PB ₇ to PB ₀)	(Initial value)
1	TPC outputs TP ₁₅ to TP ₈ are enabled (NDR15 to NDR8 are transferred to PB ₇ to PB ₀)	

11.2.9 TPC Output Control Register (TPCR)

TPCR is an 8-bit readable/writable register that selects output trigger signals for TPC outputs on a group-by-group basis.

Bit	7	6	5	4	3	2	1	0
	G3CMS1	G3CMS0	G2CMS1	G2CMS0	G1CMS1	G1CMS0	G0CMS1	G0CMS0
Initial value	1	1	1	1	1	1	1	1
Read/Write	R/W	R/W	R/W	R/W	R/W	R/W	R/W	R/W

<p>Group 3 compare match select 1 and 0 These bits select the compare match event that triggers TPC output group 3 (TP₁₅ to TP₁₂)</p>	<p>Group 2 compare match select 1 and 0 These bits select the compare match event that triggers TPC output group 2 (TP₁₁ to TP₈)</p>	<p>Group 1 compare match select 1 and 0 These bits select the compare match event that triggers TPC output group 1 (TP₇ to TP₄)</p>	<p>Group 0 compare match select 1 and 0 These bits select the compare match event that triggers TPC output group 0 (TP₃ to TP₀)</p>
--	---	--	--

TPCR is initialized to H'FF by a reset and in hardware standby mode. It is not initialized in software standby mode.

Bits 7 and 6—Group 3 Compare Match Select 1 and 0 (G3CMS1, G3CMS0): These bits select the compare match event that triggers TPC output group 3 (TP₁₅ to TP₁₂).

Bit 7 G3CMS1	Bit 6 G3CMS0	Description
0	0	TPC output group 3 (TP ₁₅ to TP ₁₂) is triggered by compare match in 16-bit timer channel 0
	1	TPC output group 3 (TP ₁₅ to TP ₁₂) is triggered by compare match in 16-bit timer channel 1
1	0	TPC output group 3 (TP ₁₅ to TP ₁₂) is triggered by compare match in 16-bit timer channel 2
	1	TPC output group 3 (TP ₁₅ to TP ₁₂) is triggered by compare match in 16-bit timer channel 2 (Initial value)

Bits 5 and 4—Group 2 Compare Match Select 1 and 0 (G2CMS1, G2CMS0): These bits select the compare match event that triggers TPC output group 2 (TP₁₁ to TP₈).

Bit 5 G2CMS1	Bit 4 G2CMS0	Description
0	0	TPC output group 2 (TP ₁₁ to TP ₈) is triggered by compare match in 16-bit timer channel 0
	1	TPC output group 2 (TP ₁₁ to TP ₈) is triggered by compare match in 16-bit timer channel 1
1	0	TPC output group 2 (TP ₁₁ to TP ₈) is triggered by compare match in 16-bit timer channel 2
	1	TPC output group 2 (TP ₁₁ to TP ₈) is triggered by compare match in 16-bit timer channel 2 (Initial value)

Bits 3 and 2—Group 1 Compare Match Select 1 and 0 (G1CMS1, G1CMS0): These bits select the compare match event that triggers TPC output group 1 (TP₇ to TP₄).

Bit 3 G1CMS1	Bit 2 G1CMS0	Description
0	0	TPC output group 1 (TP ₇ to TP ₄) is triggered by compare match in 16-bit timer channel 0
	1	TPC output group 1 (TP ₇ to TP ₄) is triggered by compare match in 16-bit timer channel 1
1	0	TPC output group 1 (TP ₇ to TP ₄) is triggered by compare match in 16-bit timer channel 2
	1	TPC output group 1 (TP ₇ to TP ₄) is triggered by compare match in 16-bit timer channel 2 (Initial value)

Bits 1 and 0—Group 0 Compare Match Select 1 and 0 (G0CMS1, G0CMS0): These bits select the compare match event that triggers TPC output group 0 (TP₃ to TP₀).

Bit 1 G0CMS1	Bit 0 G0CMS0	Description
0	0	TPC output group 0 (TP ₃ to TP ₀) is triggered by compare match in 16-bit timer channel 0
	1	TPC output group 0 (TP ₃ to TP ₀) is triggered by compare match in 16-bit timer channel 1
1	0	TPC output group 0 (TP ₃ to TP ₀) is triggered by compare match in 16-bit timer channel 2
	1	TPC output group 0 (TP ₃ to TP ₀) is triggered by compare match in 16-bit timer channel 2 (Initial value)

11.2.10 TPC Output Mode Register (TPMR)

TPMR is an 8-bit readable/writable register that selects normal or non-overlapping TPC output for each group.

Bit	7	6	5	4	3	2	1	0
	—	—	—	—	G3NOV	G2NOV	G1NOV	G0NOV
Initial value	1	1	1	1	0	0	0	0
Read/Write	—	—	—	—	R/W	R/W	R/W	R/W

Reserved bits

Group 3 non-overlap

Selects non-overlapping TPC output for group 3 (TP₁₅ to TP₁₂)

Group 2 non-overlap

Selects non-overlapping TPC output for group 2 (TP₁₁ to TP₈)

Group 1 non-overlap

Selects non-overlapping TPC output for group 1 (TP₇ to TP₄)

Group 0 non-overlap

Selects non-overlapping TPC output for group 0 (TP₃ to TP₀)

The output trigger period of a non-overlapping TPC output waveform is set in general register B (GRB) in the 16-bit timer channel selected for output triggering. The non-overlap margin is set in general register A (GRA). The output values change at compare match A and B. For details see section 11.3.4, Non-Overlapping TPC Output.

TPMR is initialized to H'F0 by a reset and in hardware standby mode. It is not initialized in software standby mode.

Bits 7 to 4—Reserved: These bits cannot be modified and are always read as 1.

Bit 3—Group 3 Non-Overlap (G3NOV): Selects normal or non-overlapping TPC output for group 3 (TP₁₅ to TP₁₂).

Bit 3

G3NOV	Description	
0	Normal TPC output in group 3 (output values change at compare match A in the selected 16-bit timer channel)	(Initial value)
1	Non-overlapping TPC output in group 3 (independent 1 and 0 output at compare match A and B in the selected 16-bit timer channel)	

Bit 2—Group 2 Non-Overlap (G2NOV): Selects normal or non-overlapping TPC output for group 2 (TP₁₁ to TP₈).

Bit 2

G2NOV	Description	
0	Normal TPC output in group 2 (output values change at compare match A in the selected 16-bit timer channel)	(Initial value)
1	Non-overlapping TPC output in group 2 (independent 1 and 0 output at compare match A and B in the selected 16-bit timer channel)	

Bit 1—Group 1 Non-Overlap (G1NOV): Selects normal or non-overlapping TPC output for group 1 (TP₇ to TP₄).

Bit 1

G1NOV	Description	
0	Normal TPC output in group 1 (output values change at compare match A in the selected 16-bit timer channel)	(Initial value)
1	Non-overlapping TPC output in group 1 (independent 1 and 0 output at compare match A and B in the selected 16-bit timer channel)	

Bit 0—Group 0 Non-Overlap (G0NOV): Selects normal or non-overlapping TPC output for group 0 (TP₃ to TP₀).

Bit 0

G0NOV	Description	
0	Normal TPC output in group 0 (output values change at compare match A in the selected 16-bit timer channel)	(Initial value)
1	Non-overlapping TPC output in group 0 (independent 1 and 0 output at compare match A and B in the selected 16-bit timer channel)	

11.3 Operation

11.3.1 Overview

When corresponding bits in PADDR or PBDDR and NDERA or NDERB are set to 1, TPC output is enabled. The TPC output initially consists of the corresponding PADDR or PBDDR contents. When a compare-match event selected in TPCR occurs, the corresponding NDRA or NDRB bit contents are transferred to PADDR or PBDDR to update the output values.

Figure 11.2 illustrates the TPC output operation. Table 11.3 summarizes the TPC operating conditions.

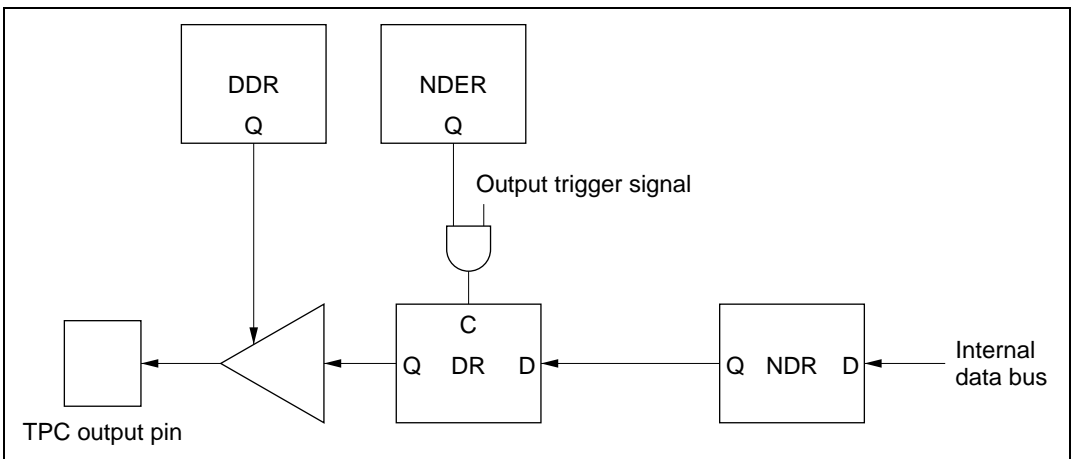

Figure 11.2 TPC Output Operation

Table 11.3 TPC Operating Conditions

NDER	DDR	Pin Function
0	0	Generic input port
	1	Generic output port
1	0	Generic input port (but the DR bit is a read-only bit, and when compare match occurs, the NDR bit value is transferred to the DR bit)
	1	TPC pulse output

Sequential output of up to 16-bit patterns is possible by writing new output data to NDRA and NDRB before the next compare match. For information on non-overlapping operation, see section 11.3.4, Non-Overlapping TPC Output.

11.3.2 Output Timing

If TPC output is enabled, NDRA/NDRB contents are transferred to PADR/PBDR and output when the selected compare match event occurs. Figure 11.3 shows the timing of these operations for the case of normal output in groups 2 and 3, triggered by compare match A.

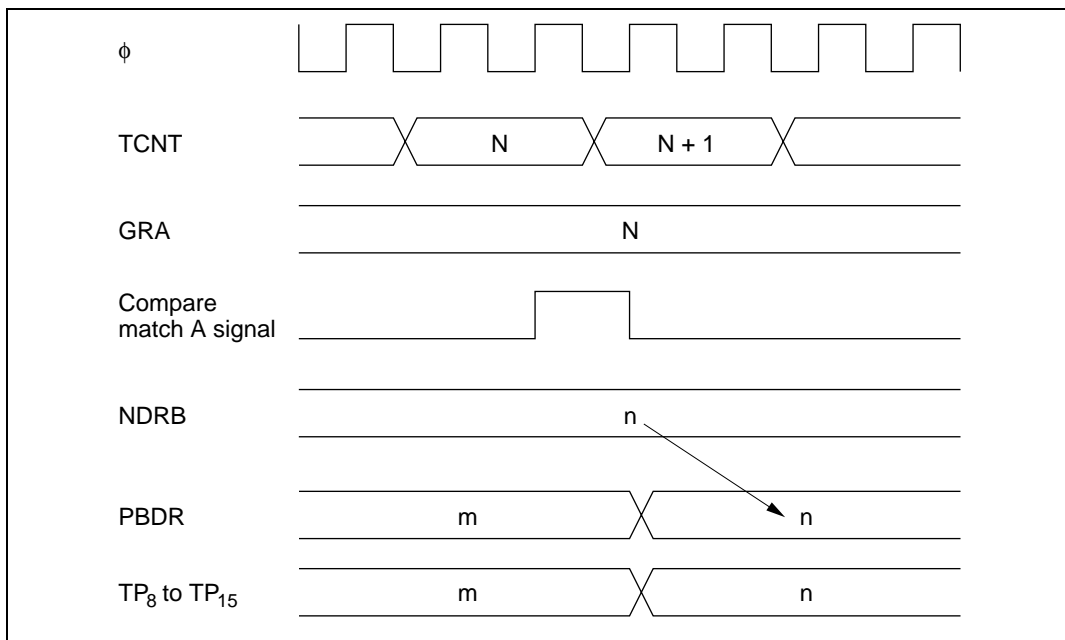

Figure 11.3 Timing of Transfer of Next Data Register Contents and Output (Example)

11.3.3 Normal TPC Output

Sample Setup Procedure for Normal TPC Output: Figure 11.4 shows a sample procedure for setting up normal TPC output.

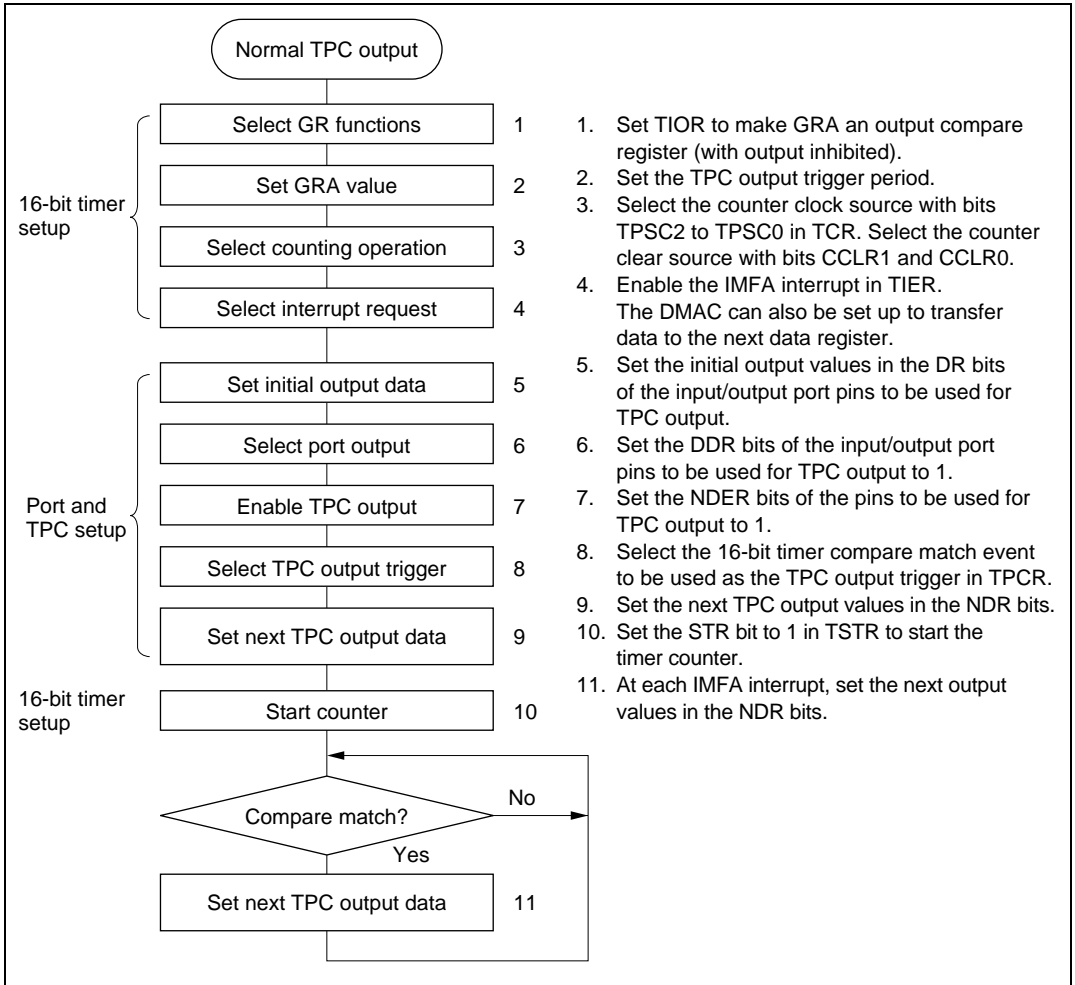

Figure 11.4 Setup Procedure for Normal TPC Output (Example)

Example of Normal TPC Output (Example of Five-Phase Pulse Output): Figure 11.5 shows an example in which the TPC is used for cyclic five-phase pulse output.

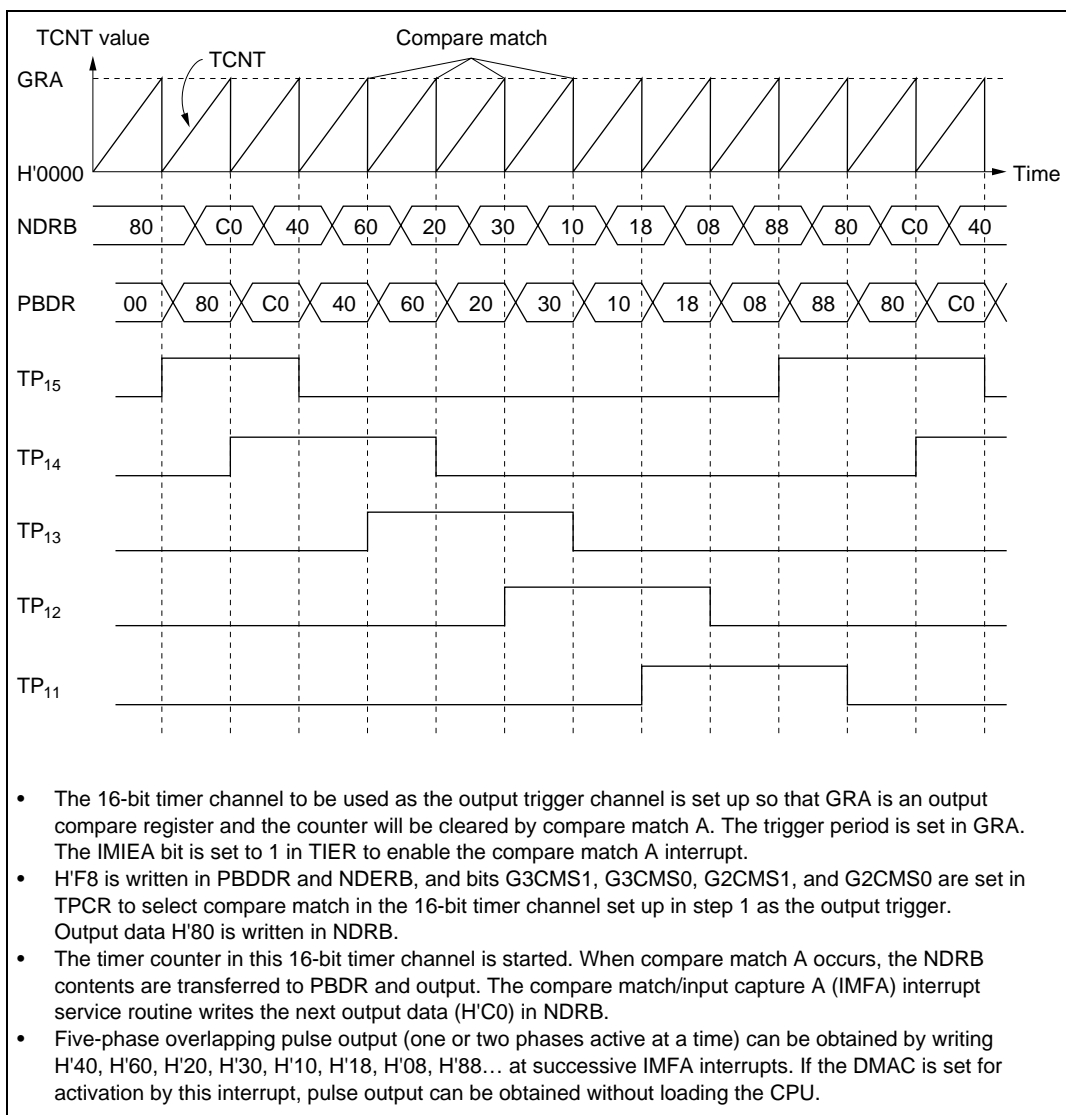

Figure 11.5 Normal TPC Output Example (Five-Phase Pulse Output)

11.3.4 Non-Overlapping TPC Output

Sample Setup Procedure for Non-Overlapping TPC Output: Figure 11.6 shows a sample procedure for setting up non-overlapping TPC output.

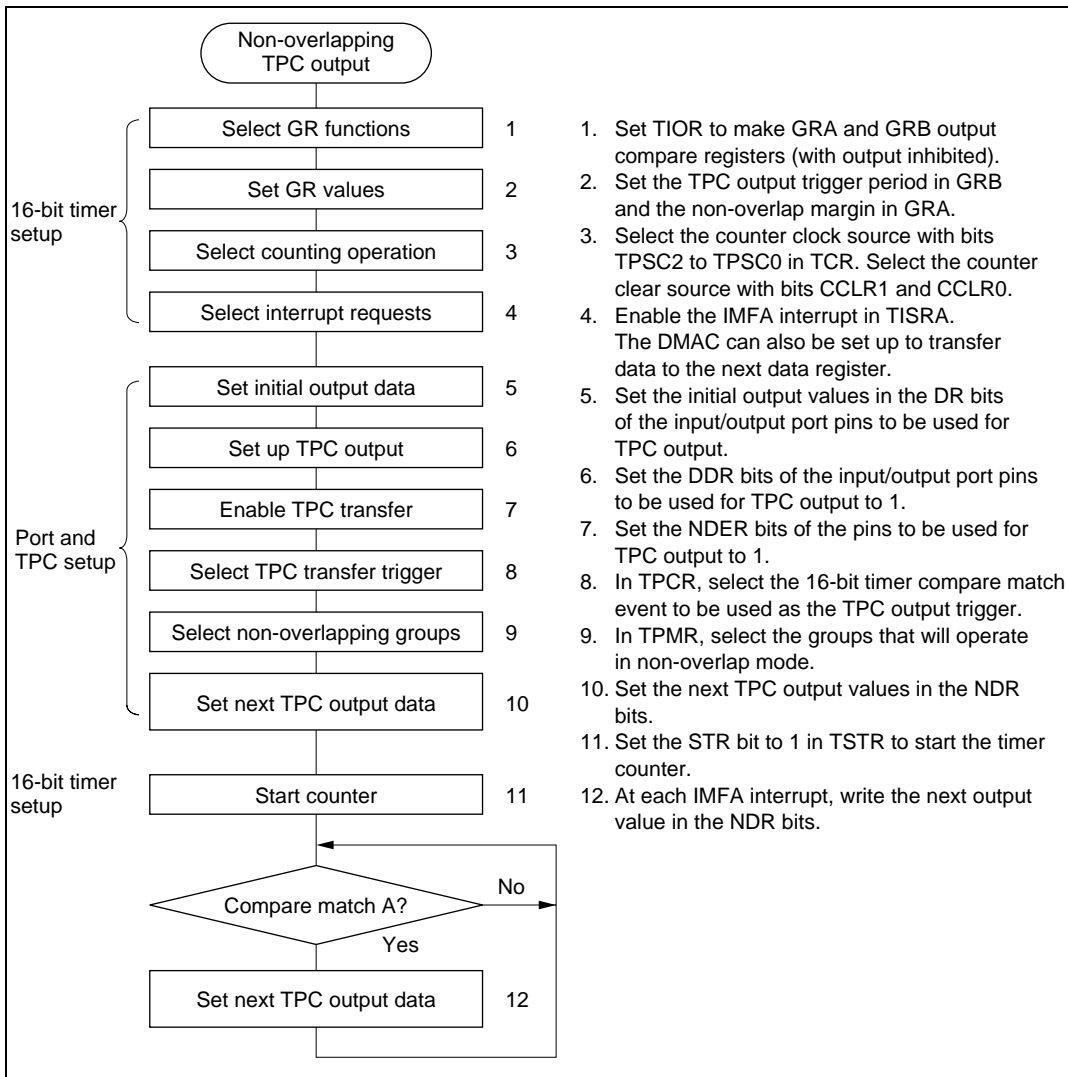
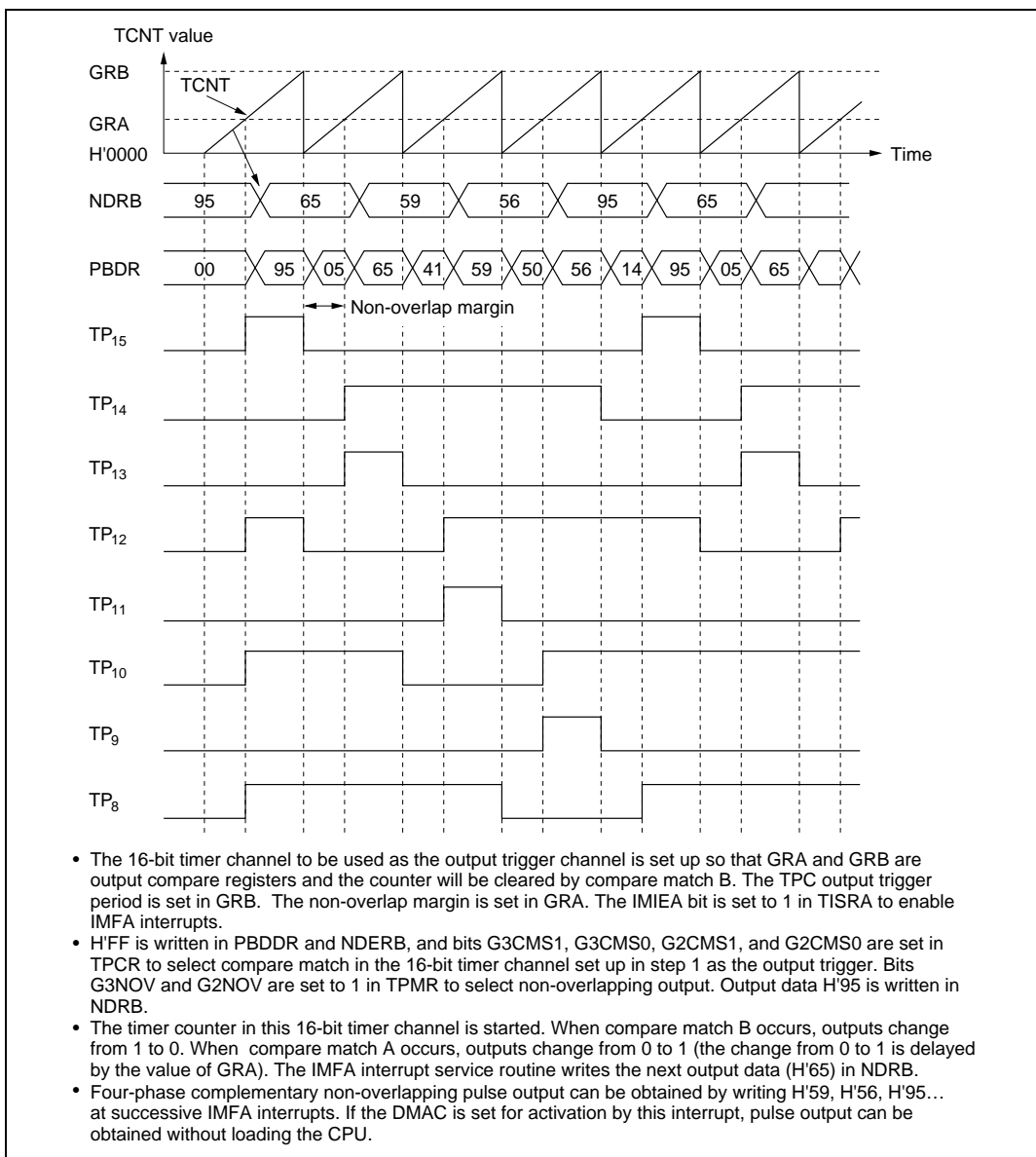

Figure 11.6 Setup Procedure for Non-Overlapping TPC Output (Example)

Example of Non-Overlapping TPC Output (Example of Four-Phase Complementary Non-Overlapping Output): Figure 11.7 shows an example of the use of TPC output for four-phase complementary non-overlapping pulse output.



- The 16-bit timer channel to be used as the output trigger channel is set up so that GRA and GRB are output compare registers and the counter will be cleared by compare match B. The TPC output trigger period is set in GRB. The non-overlap margin is set in GRA. The IMIEA bit is set to 1 in TISRA to enable IMFA interrupts.
- H'FF is written in PBDDR and NDERB, and bits G3CMS1, G3CMS0, G2CMS1, and G2CMS0 are set in TPCR to select compare match in the 16-bit timer channel set up in step 1 as the output trigger. Bits G3NOV and G2NOV are set to 1 in TPMPR to select non-overlapping output. Output data H'95 is written in NDRB.
- The timer counter in this 16-bit timer channel is started. When compare match B occurs, outputs change from 1 to 0. When compare match A occurs, outputs change from 0 to 1 (the change from 0 to 1 is delayed by the value of GRA). The IMFA interrupt service routine writes the next output data (H'65) in NDRB.
- Four-phase complementary non-overlapping pulse output can be obtained by writing H'59, H'56, H'95... at successive IMFA interrupts. If the DMAC is set for activation by this interrupt, pulse output can be obtained without loading the CPU.

Figure 11.7 Non-Overlapping TPC Output Example (Four-Phase Complementary Non-Overlapping Pulse Output)

11.3.5 TPC Output Triggering by Input Capture

TPC output can be triggered by 16-bit timer input capture as well as by compare match. If GRA functions as an input capture register in the 16-bit timer channel selected in TPCR, TPC output will be triggered by the input capture signal. Figure 11.8 shows the timing.

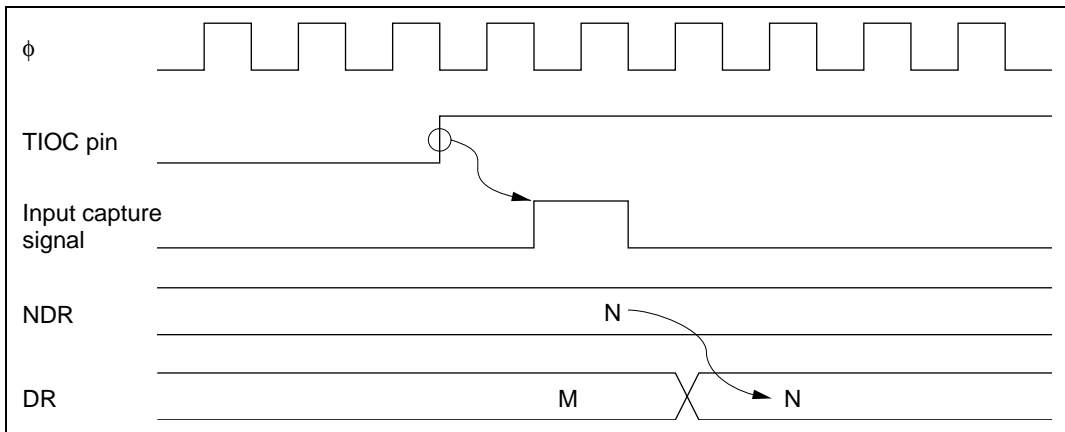

Figure 11.8 TPC Output Triggering by Input Capture (Example)

11.4 Usage Notes

11.4.1 Operation of TPC Output Pins

TP₀ to TP₁₅ are multiplexed with 16-bit timer, DMAC, address bus, and other pin functions. When 16-bit timer, DMAC, or address output is enabled, the corresponding pins cannot be used for TPC output. The data transfer from NDR bits to DR bits takes place, however, regardless of the usage of the pin.

Pin functions should be changed only under conditions in which the output trigger event will not occur.

11.4.2 Note on Non-Overlapping Output

During non-overlapping operation, the transfer of NDR bit values to DR bits takes place as follows.

1. NDR bits are always transferred to DR bits at compare match A.
2. At compare match B, NDR bits are transferred only if their value is 0. Bits are not transferred if their value is 1.

Figure 11.9 illustrates the non-overlapping TPC output operation.

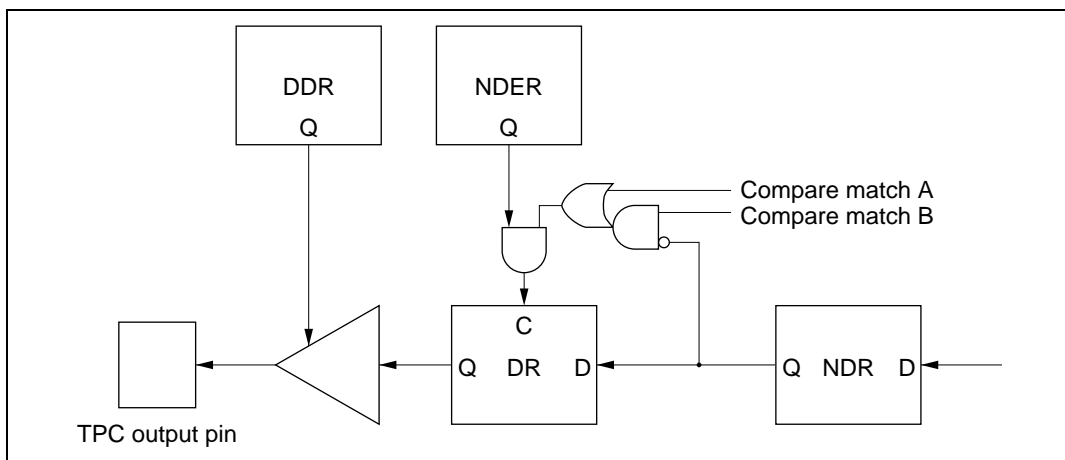

Figure 11.9 Non-Overlapping TPC Output

Therefore, 0 data can be transferred ahead of 1 data by making compare match B occur before compare match A. NDR contents should not be altered during the interval from compare match B to compare match A (the non-overlap margin).

This can be accomplished by having the IMFA interrupt service routine write the next data in NDR, or by having the IMFA interrupt activate the DMAC. The next data must be written before the next compare match B occurs.

Figure 11.10 shows the timing relationships.

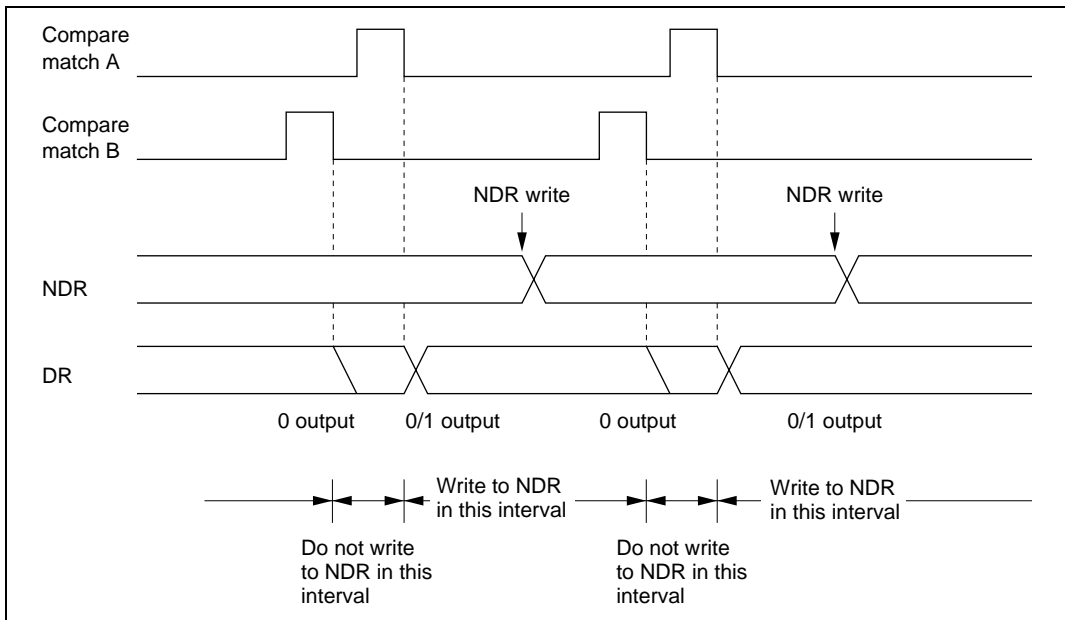

Figure 11.10 Non-Overlapping Operation and NDR Write Timing

Section 12 Watchdog Timer

12.1 Overview

The H8/3068F has an on-chip watchdog timer (WDT). The WDT has two selectable functions: it can operate as a watchdog timer to supervise system operation, or it can operate as an interval timer. As a watchdog timer, it generates a reset signal for the H8/3068F chip if a system crash allows the timer counter (TCNT) to overflow before being rewritten. In interval timer operation, an interval timer interrupt is requested at each TCNT overflow.

12.1.1 Features

WDT features are listed below.

- Selection of eight counter clock sources
 $\phi/2$, $\phi/32$, $\phi/64$, $\phi/128$, $\phi/256$, $\phi/512$, $\phi/2048$, or $\phi/4096$
- Interval timer option
- Timer counter overflow generates a reset signal or interrupt.
The reset signal is generated in watchdog timer operation. An interval timer interrupt is generated in interval timer operation.
- Watchdog timer reset signal resets the entire H8/3068F internally.
The reset signal generated by timer counter overflow during watchdog timer operation resets the entire H8/3068F internally.

12.1.2 Block Diagram

Figure 12.1 shows a block diagram of the WDT.

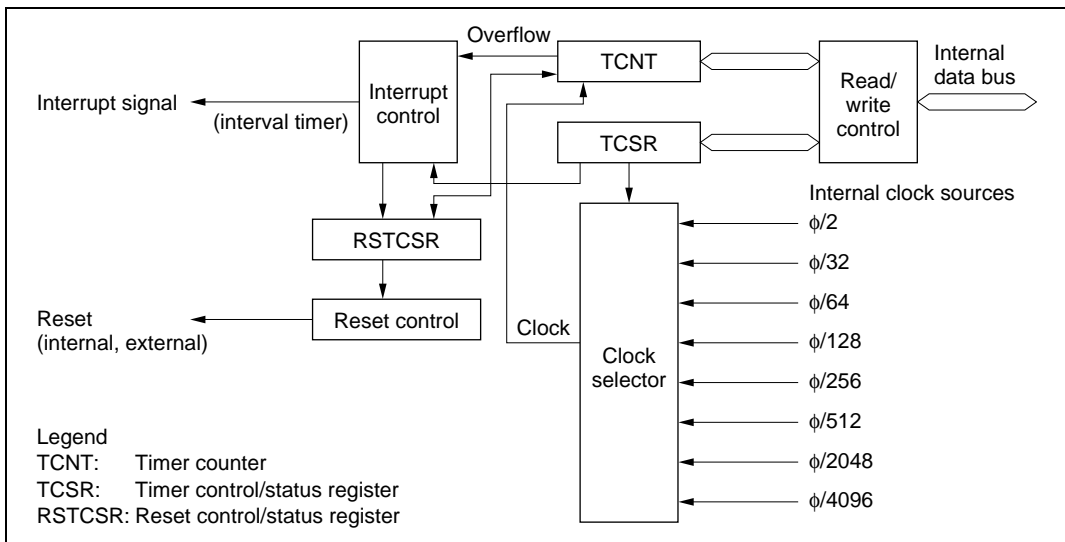

Figure 12.1 WDT Block Diagram

12.1.3 Register Configuration

Table 12.1 summarizes the WDT registers.

Table 12.1 WDT Registers

Address* ¹		Name	Abbreviation	R/W	Initial Value
Write* ²	Read				
H'FFF8C	H'FFF8C	Timer control/status register	TCSR	R/(W)* ³	H'18
	H'FFF8D	Timer counter	TCNT	R/W	H'00
H'FFF8E	H'FFF8F	Reset control/status register	RSTCSR	R/(W)* ³	H'3F

Notes: 1. Lower 20 bits of the address in advanced mode.

2. Write word data starting at this address.

3. Only 0 can be written in bit 7, to clear the flag.

12.2 Register Descriptions

12.2.1 Timer Counter (TCNT)

TCNT is an 8-bit readable and writable up-counter.

Bit	7	6	5	4	3	2	1	0
Initial value	0	0	0	0	0	0	0	0
Read/Write	R/W	R/W	R/W	R/W	R/W	R/W	R/W	R/W

Note: TCNT is write-protected by a password. For details see section 12.2.4, Notes on Register Access.

When the TME bit is set to 1 in TCSR, TCNT starts counting pulses generated from an internal clock source selected by bits CKS2 to CKS0 in TCSR. When the count overflows (changes from H'FF to H'00), the OVF bit is set to 1 in TCSR. TCNT is initialized to H'00 by a reset and when the TME bit is cleared to 0.

12.2.2 Timer Control/Status Register (TCSR)

TCSR is an 8-bit readable and writable register. Its functions include selecting the timer mode and clock source.

Bit	7	6	5	4	3	2	1	0
	OVF	WT/IT	TME	—	—	CKS2	CKS1	CKS0
Initial value	0	0	0	1	1	0	0	0
Read/Write	R/(W)*	R/W	R/W	—	—	R/W	R/W	R/W

Overflow flag
 Status flag indicating overflow

Timer mode select
 Selects the mode

Timer enable
 Selects whether TCNT runs or halts

Reserved bits

Clock select
 These bits select the TCNT clock source

Notes: TCSR is write-protected by a password. For details see section 12.2.4, Notes on Register Access.

* Only 0 can be written, to clear the flag.

Bits 7 to 5 are initialized to 0 by a reset and in standby mode. Bits 2 to 0 are initialized to 0 by a reset. In software standby mode bits 2 to 0 are not initialized, but retain their previous values.

Bit 7—Overflow Flag (OVF): This status flag indicates that the timer counter has overflowed from H'FF to H'00.

Bit 7 OVF	Description	
0	[Clearing condition] Cleared by reading OVF when OVF = 1, then writing 0 in OVF	(Initial value)
1	[Setting condition] Set when TCNT changes from H'FF to H'00	

Bit 6—Timer Mode Select (WT/ $\overline{\text{IT}}$): Selects whether to use the WDT as a watchdog timer or interval timer. If used as an interval timer, the WDT generates an interval timer interrupt request when TCNT overflows. If used as a watchdog timer, the WDT generates a reset signal when TCNT overflows.

Bit 6 WT/ $\overline{\text{IT}}$	Description	
0	Interval timer: requests interval timer interrupts	(Initial value)
1	Watchdog timer: generates a reset signal	

Bit 5—Timer Enable (TME): Selects whether TCNT runs or is halted. When WT/ $\overline{\text{IT}}$ = 1, clear the software standby bit (SSBY) to 0 in SYSCR before setting TME. When setting SSBY to 1, TME should be cleared to 0.

Bit 5 TME	Description	
0	TCNT is initialized to H'00 and halted	(Initial value)
1	TCNT is counting	

Bits 4 and 3—Reserved: These bits cannot be modified and are always read as 1.

Bits 2 to 0—Clock Select 2 to 0 (CKS2/1/0): These bits select one of eight internal clock sources, obtained by prescaling the system clock (ϕ), for input to TCNT.

Bit 2 CKS2	Bit 1 CKS1	Bit 0 CKS0	Description
0	0	0	$\phi/2$ (Initial value)
		1	$\phi/32$
	1	0	$\phi/64$
		1	$\phi/128$
1	0	0	$\phi/256$
		1	$\phi/512$
	1	0	$\phi/2048$
		1	$\phi/4096$

12.2.3 Reset Control/Status Register (RSTCSR)

RSTCSR is an 8-bit readable and writable register that indicates when a reset signal has been generated by watchdog timer overflow, and controls external output of the reset signal.

Bit	7	6	5	4	3	2	1	0
	WRST	—	—	—	—	—	—	—
Initial value	0	0	1	1	1	1	1	1
Read/Write	R/(W)*	R/W	—	—	—	—	—	—

Reserved bits

Watchdog timer reset
Indicates that a reset signal has been generated

Notes: RSTCSR is write-protected by a password. For details see section 12.2.4, Notes on Register Access.

* Only 0 can be written in bit 7, to clear the flag.

Bits 7 and 6 are initialized by input of a reset signal at the $\overline{\text{RES}}$ pin. They are not initialized by reset signals generated by watchdog timer overflow.

Bit 7—Watchdog Timer Reset (WRST): During watchdog timer operation, this bit indicates that TCNT has overflowed and generated a reset signal. This reset signal resets the entire H8/3068F chip internally.

Bit 7

WRST	Description
0	[Clearing condition] Reset signal at $\overline{\text{RES}}$ pin. Read WRST when WRST =1, then write 0 in WRST. (Initial value)
1	[Setting condition] Set when TCNT overflow generates a reset signal during watchdog timer operation

Bit 6—Reserved

Bits 5 to 0—Reserved: These bits cannot be modified and are always read as 1.

12.2.4 Notes on Register Access

The watchdog timer's TCNT, TCSR, and RSTCSR registers differ from other registers in being more difficult to write. The procedures for writing and reading these registers are given below.

Writing to TCNT and TCSR: These registers must be written by a word transfer instruction. They cannot be written by byte instructions. Figure 12.2 shows the format of data written to TCNT and TCSR. TCNT and TCSR both have the same write address. The write data must be contained in the lower byte of the written word. The upper byte must contain H'5A (password for TCNT) or H'A5 (password for TCSR). This transfers the write data from the lower byte to TCNT or TCSR.

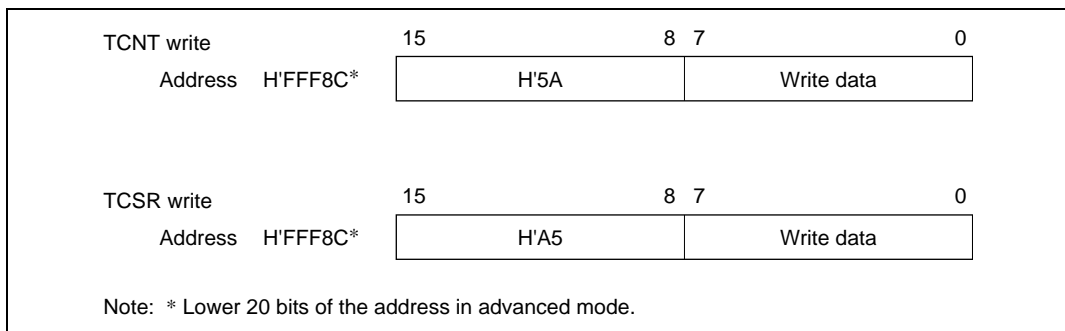

Figure 12.2 Format of Data Written to TCNT and TCSR

Writing to RSTCSR: RSTCSR must be written by a word transfer instruction. It cannot be written by byte transfer instructions. Figure 12.3 shows the format of data written to RSTCSR. To write 0 in the WRST bit, the write data must have H'A5 in the upper byte and H'00 in the lower byte. The data (H'00) in the lower byte is written to RSTCSR, clearing the WRST bit to 0. To write to the RSTOE bit, the upper byte must contain H'5A and the lower byte must contain the write data. Writing this word transfers a write data value into the RSTOE bit.

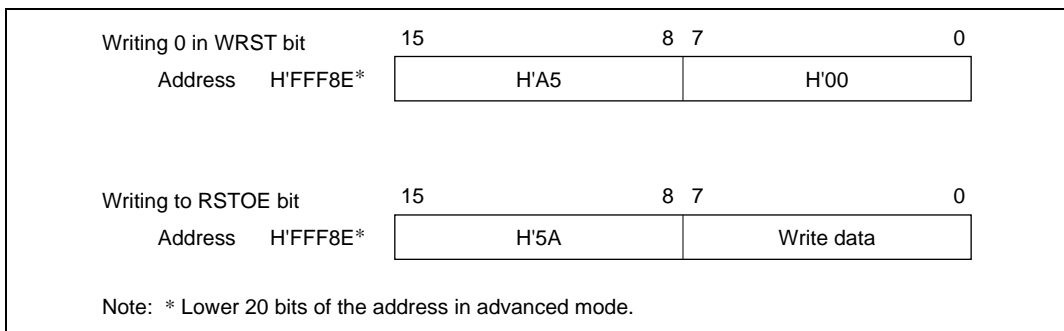

Figure 12.3 Format of Data Written to RSTCSR

Reading TCNT, TCSR, and RSTCSR: These registers are read like other registers. Reading TCNT, TCSR, and RSTCSR: These registers are read like other registers. Byte transfer instructions can be used. The read addresses are H'FFF8C for TCSR, H'FFF8D for TCNT, and H'FFF8F for RSTCSR, as listed in table 12.2.

Table 12.2 Read Addresses of TCNT, TCSR, and RSTCSR

Address*	Register
H'FFF8C	TCSR
H'FFF8D	TCNT
H'FFF8F	RSTCSR

Note: * Lower 20 bits of the address in advanced mode.

12.3 Operation

Operations when the WDT is used as a watchdog timer and as an interval timer are described below.

12.3.1 Watchdog Timer Operation

Figure 12.4 illustrates watchdog timer operation. To use the WDT as a watchdog timer, set the WT/\overline{IT} and TME bits to 1 in $TCSR$. Software must prevent $TCNT$ overflow by rewriting the $TCNT$ value (normally by writing $H'00$) before overflow occurs. If $TCNT$ fails to be rewritten and overflows due to a system crash etc., the H8/3068F is internally reset for a duration of 518 states.

A watchdog reset has the same vector as a reset generated by input at the \overline{RES} pin. Software can distinguish a \overline{RES} reset from a watchdog reset by checking the $WRST$ bit in $RSTCSR$.

If a \overline{RES} reset and a watchdog reset occur simultaneously, the \overline{RES} reset takes priority.

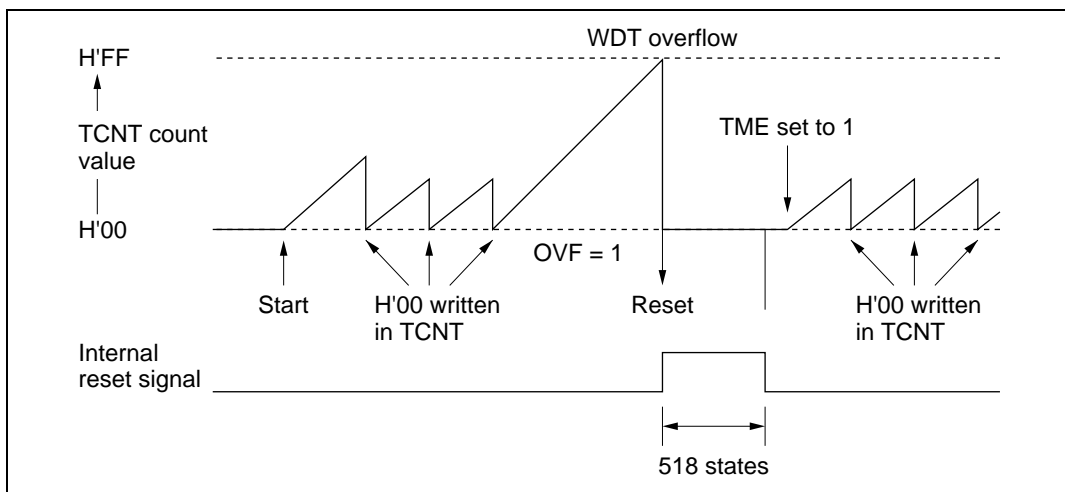

Figure 12.4 Operation in Watchdog Timer Mode

12.3.2 Interval Timer Operation

Figure 12.5 illustrates interval timer operation. To use the WDT as an interval timer, clear bit $\overline{WT/IT}$ to 0 and set bit TME to 1 in TCSR. An interval timer interrupt request is generated at each TCNT overflow. This function can be used to generate interval timer interrupts at regular intervals.

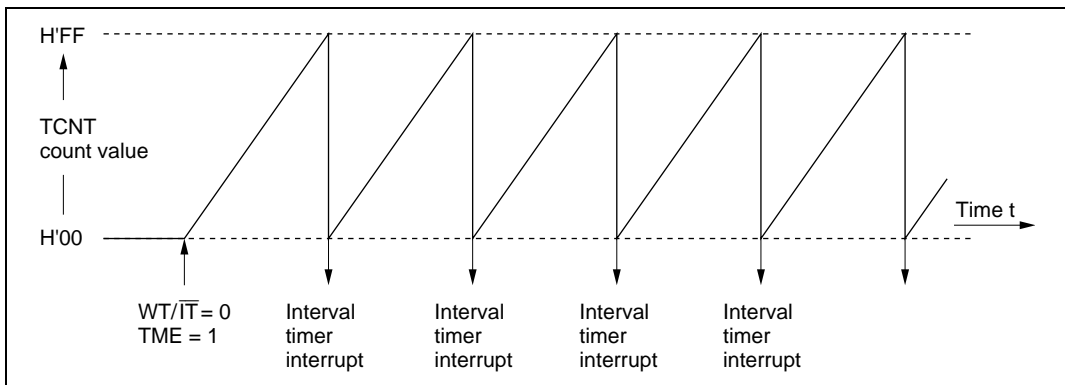

Figure 12.5 Interval Timer Operation

12.3.3 Timing of Setting of Overflow Flag (OVF)

Figure 12.6 shows the timing of setting of the OVF flag. The OVF flag is set to 1 when TCNT overflows. At the same time, a reset signal is generated in watchdog timer operation, or an interval timer interrupt is generated in interval timer operation.

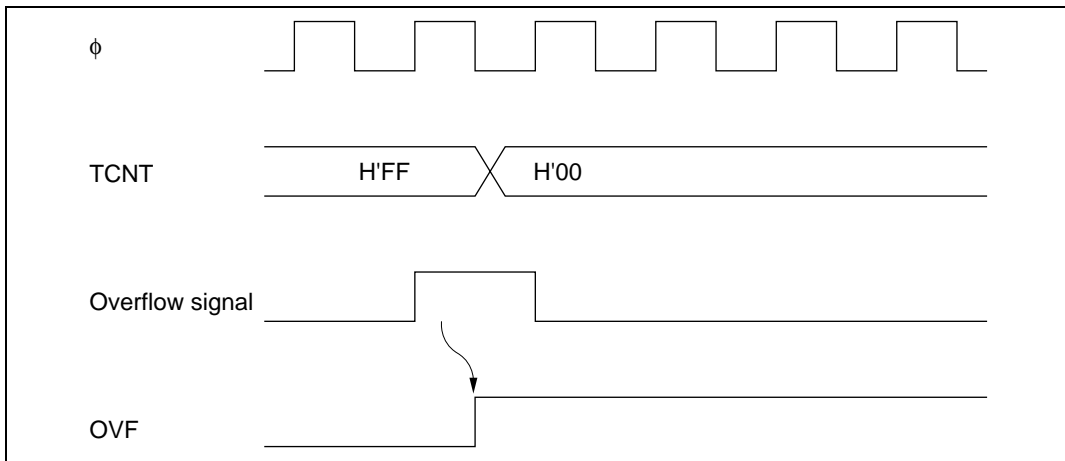

Figure 12.6 Timing of Setting of OVF

12.3.4 Timing of Setting of Watchdog Timer Reset Bit (WRST)

The WRST bit in RSTCSR is valid when bits $\overline{WT/IT}$ and TME are both set to 1 in TCSR.

Figure 12.7 shows the timing of setting of WRST and the internal reset timing. The WRST bit is set to 1 when TCNT overflows and OVF is set to 1. At the same time an internal reset signal is generated for the entire H8/3068F chip. This internal reset signal clears OVF to 0, but the WRST bit remains set to 1. The reset routine must therefore clear the WRST bit.

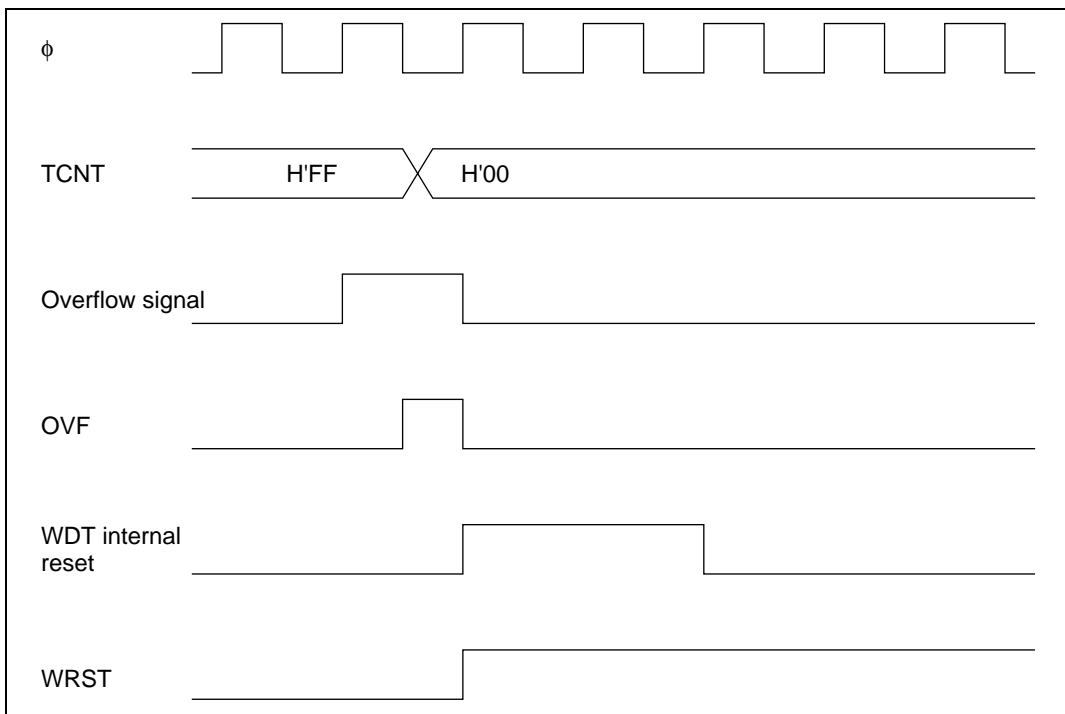

Figure 12.7 Timing of Setting of WRST Bit and Internal Reset

12.4 Interrupts

During interval timer operation, an overflow generates an interval timer interrupt (WOVI). The interval timer interrupt is requested whenever the OVF bit is set to 1 in TCSR.

12.5 Usage Notes

Contention between TCNT Write and Increment: If a timer counter clock pulse is generated during the T_3 state of a write cycle to TCNT, the write takes priority and the timer count is not incremented. See figure 12.8.

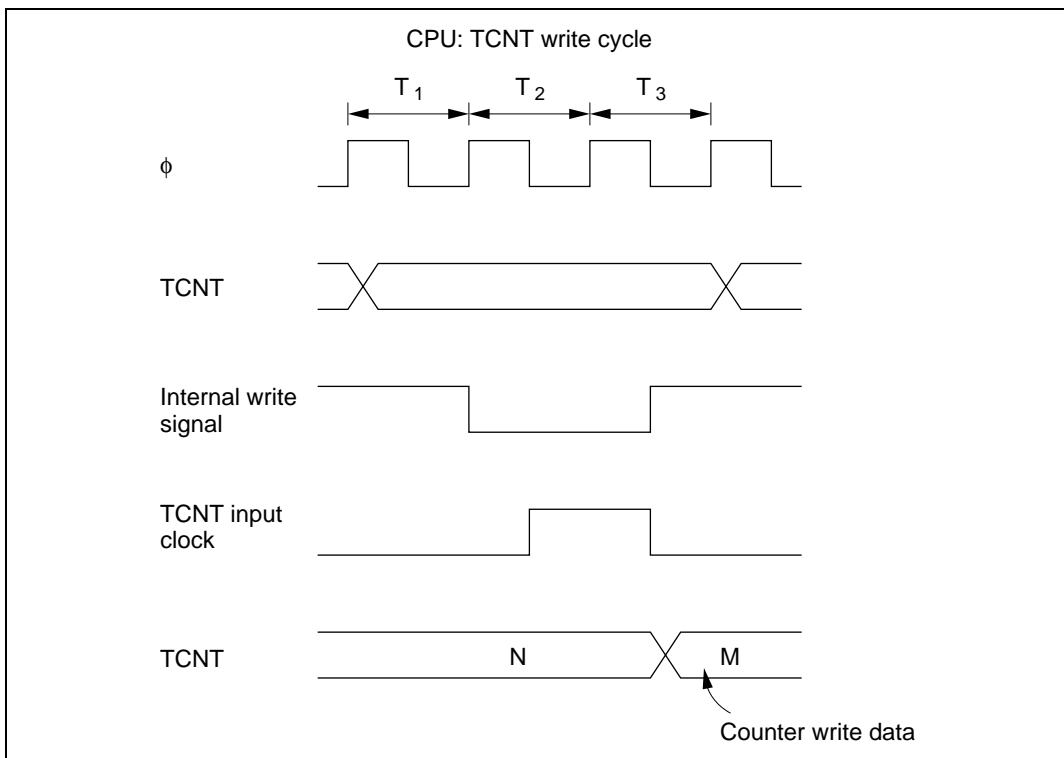

Figure 12.8 Contention between TCNT Write and Count up

Changing CKS2 to CKS0 Bit: Halt TCNT by clearing the TME bit to 0 in TCSR before changing the values of bits CKS2 to CKS0.

Section 13 Serial Communication Interface

13.1 Overview

The H8/3068F has a serial communication interface (SCI) with three independent channels. All three channels have identical functions. The SCI can communicate in both asynchronous and synchronous mode. It also has a multiprocessor communication function for serial communication among two or more processors.

When the SCI is not used, it can be halted to conserve power. Each SCI channel can be halted independently. For details, see section 20.6, Module Standby Function.

The SCI also has a smart card interface function conforming to the ISO/IEC 7816-3 (Identification Card) standard. This function supports serial communication with a smart card. Switching between the normal serial communication interface and the smart card interface is carried out by means of a register setting.

13.1.1 Features

SCI features are listed below.

- Selection of synchronous or asynchronous mode for serial communication

Asynchronous mode

Serial data communication is synchronized one channel at a time. The SCI can communicate with a universal asynchronous receiver/transmitter (UART), asynchronous communication interface adapter (ACIA), or other chip that employs standard asynchronous communication. It can also communicate with two or more other processors using the multiprocessor communication function. There are twelve selectable serial data transfer formats.

- Data length: 7 or 8 bits
- Stop bit length: 1 or 2 bits
- Parity: even/odd/none
- Multiprocessor bit: 1 or 0
- Receive error detection: parity, overrun, and framing errors
- Break detection: by reading the RxD level directly when a framing error occurs

Synchronous mode

Serial data communication is synchronized with a clock signal. The SCI can communicate with other chips having a synchronous communication function.

There is a single serial data communication format.

— Data length: 8 bits

— Receive error detection: overrun errors

- Full-duplex communication

The transmitting and receiving sections are independent, so the SCI can transmit and receive simultaneously. The transmitting and receiving sections are both double-buffered, so serial data can be transmitted and received continuously.

- The following settings can be made for the serial data to be transferred:

— LSB-first or MSB-first transfer

— Inversion of data logic level

- Built-in baud rate generator with selectable bit rates

- Selectable transmit/receive clock sources: internal clock from baud rate generator, or external clock from the SCK pin

- Four types of interrupts

Transmit-data-empty, transmit-end, receive-data-full, and receive-error interrupts are requested independently. The transmit-data-empty and receive-data-full interrupts from SCIO can activate the DMA controller (DMAC) to transfer data.

Features of the smart card interface are listed below.

- Asynchronous communication

— Data length: 8 bits

— Parity bits generated and checked

— Error signal output in receive mode (parity error)

— Error signal detect and automatic data retransmit in transmit mode

— Supports both direct convention and inverse convention

- Built-in baud rate generator with selectable bit rates

- Three types of interrupts

Transmit-data-empty, receive-data-full, and transmit/receive-error interrupts are requested independently. The transmit-data-empty and receive-data-full interrupts can activate the DMA controller (DMAC) to transfer data.

13.1.2 Block Diagram

Figure 13.1 shows a block diagram of the SCI.

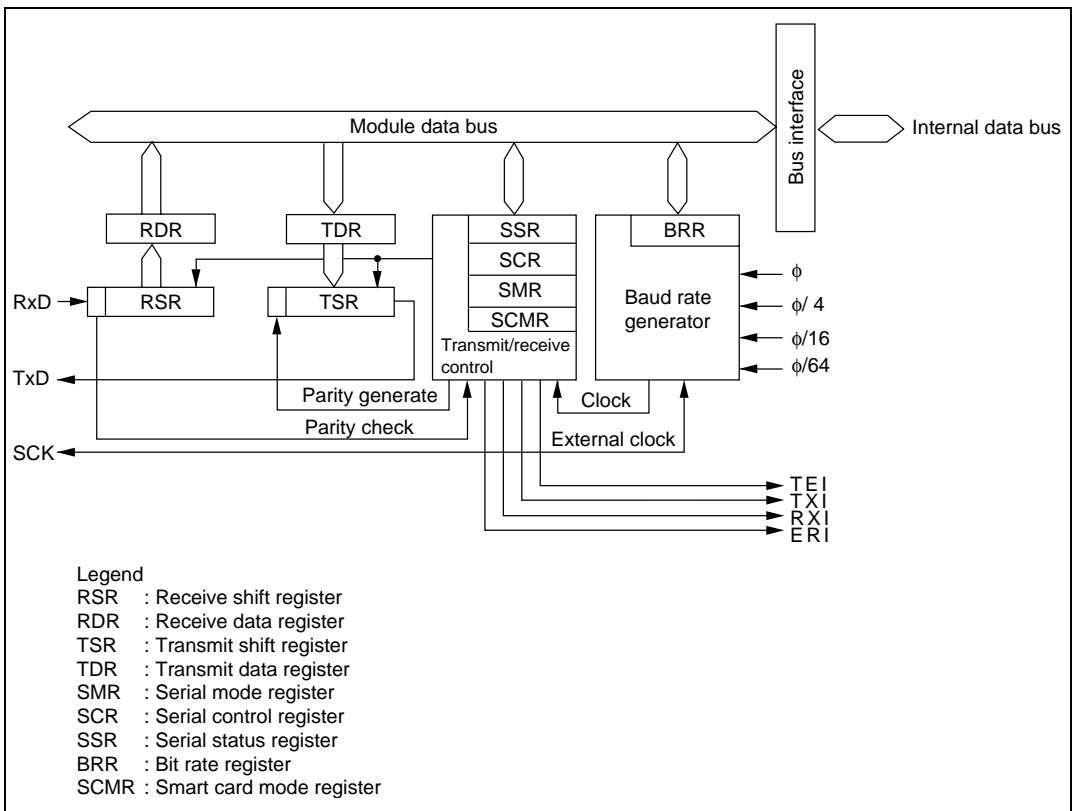

Figure 13.1 SCI Block Diagram

13.1.3 Input/Output Pins

The SCI has serial pins for each channel as listed in table 13.1.

Table 13.1 SCI Pins

Channel	Name	Abbreviation	I/O	Function
0	Serial clock pin	SCK ₀	Input/output	SCI ₀ clock input/output
	Receive data pin	RxD ₀	Input	SCI ₀ receive data input
	Transmit data pin	TxD ₀	Output	SCI ₀ transmit data output
1	Serial clock pin	SCK ₁	Input/output	SCI ₁ clock input/output
	Receive data pin	RxD ₁	Input	SCI ₁ receive data input
	Transmit data pin	TxD ₁	Output	SCI ₁ transmit data output
2	Serial clock pin	SCK ₂	Input/output	SCI ₂ clock input/output
	Receive data pin	RxD ₂	Input	SCI ₂ receive data input
	Transmit data pin	TxD ₂	Output	SCI ₂ transmit data output

13.1.4 Register Configuration

The SCI has internal registers as listed in table 13.2. These registers select asynchronous or synchronous mode, specify the data format and bit rate, control the transmitter and receiver sections, and specify switching between the serial communication interface and smart card interface.

Table 13.2 SCI Registers

Channel	Address* ¹	Name	Abbreviation	R/W	Initial Value
0	H'FFFB0	Serial mode register	SMR	R/W	H'00
	H'FFFB1	Bit rate register	BRR	R/W	H'FF
	H'FFFB2	Serial control register	SCR	R/W	H'00
	H'FFFB3	Transmit data register	TDR	R/W	H'FF
	H'FFFB4	Serial status register	SSR	R/(W)* ²	H'84
	H'FFFB5	Receive data register	RDR	R	H'00
	H'FFFB6	Smart card mode register	SCMR	R/W	H'F2
1	H'FFFB8	Serial mode register	SMR	R/W	H'00
	H'FFFB9	Bit rate register	BRR	R/W	H'FF
	H'FFFB A	Serial control register	SCR	R/W	H'00
	H'FFFB B	Transmit data register	TDR	R/W	H'FF
	H'FFFB C	Serial status register	SSR	R/(W)* ²	H'84
	H'FFFB D	Receive data register	RDR	R	H'00
	H'FFFB E	Smart card mode register	SCMR	R/W	H'F2
2	H'FFFC0	Serial mode register	SMR	R/W	H'00
	H'FFFC1	Bit rate register	BRR	R/W	H'FF
	H'FFFC2	Serial control register	SCR	R/W	H'00
	H'FFFC3	Transmit data register	TDR	R/W	H'FF
	H'FFFC4	Serial status register	SSR	R/(W)* ²	H'84
	H'FFFC5	Receive data register	RDR	R	H'00
	H'FFFC6	Smart card mode register	SCMR	R/W	H'F2

Notes: 1. Indicates the lower 20 bits of the address in advanced mode.

2. Only 0 can be written, to clear flags.

13.2 Register Descriptions

13.2.1 Receive Shift Register (RSR)

RSR is the register that receives serial data.

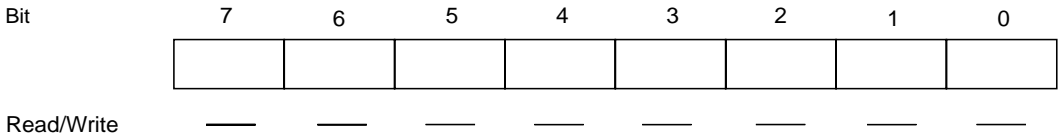

The SCI loads serial data input at the RxD pin into RSR in the order received, LSB (bit 0) first, thereby converting the data to parallel data. When one byte of data has been received, it is automatically transferred to RDR. The CPU cannot read or write RSR directly.

13.2.2 Receive Data Register (RDR)

RDR is the register that stores received serial data.

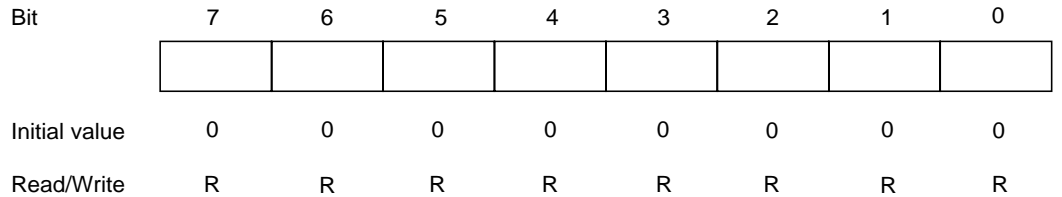

When the SCI has received one byte of serial data, it transfers the received data from RSR into RDR for storage, completing the receive operation. RSR is then ready to receive the next data. This double-buffering allows data to be received continuously.

RDR is a read-only register. Its contents cannot be modified by the CPU. RDR is initialized to H'00 by a reset and in standby mode.

13.2.3 Transmit Shift Register (TSR)

TSR is the register that transmits serial data.

Bit	7	6	5	4	3	2	1	0
Read/Write	—	—	—	—	—	—	—	—

The SCI loads transmit data from TDR to TSR, then transmits the data serially from the TxD pin, LSB (bit 0) first. After transmitting one data byte, the SCI automatically loads the next transmit data from TDR into TSR and starts transmitting it. If the TDRE flag is set to 1 in SSR, however, the SCI does not load the TDR contents into TSR. The CPU cannot read or write RSR directly.

13.2.4 Transmit Data Register (TDR)

TDR is an 8-bit register that stores data for serial transmission.

Bit	7	6	5	4	3	2	1	0
Initial value	1	1	1	1	1	1	1	1
Read/Write	R/W	R/W	R/W	R/W	R/W	R/W	R/W	R/W

When the SCI detects that TSR is empty, it moves transmit data written in TDR from TDR into TSR and starts serial transmission. Continuous serial transmission is possible by writing the next transmit data in TDR during serial transmission from TSR.

The CPU can always read and write TDR. TDR is initialized to H'FF by a reset and in standby mode.

13.2.5 Serial Mode Register (SMR)

SMR is an 8-bit register that specifies the SCI's serial communication format and selects the clock source for the baud rate generator.

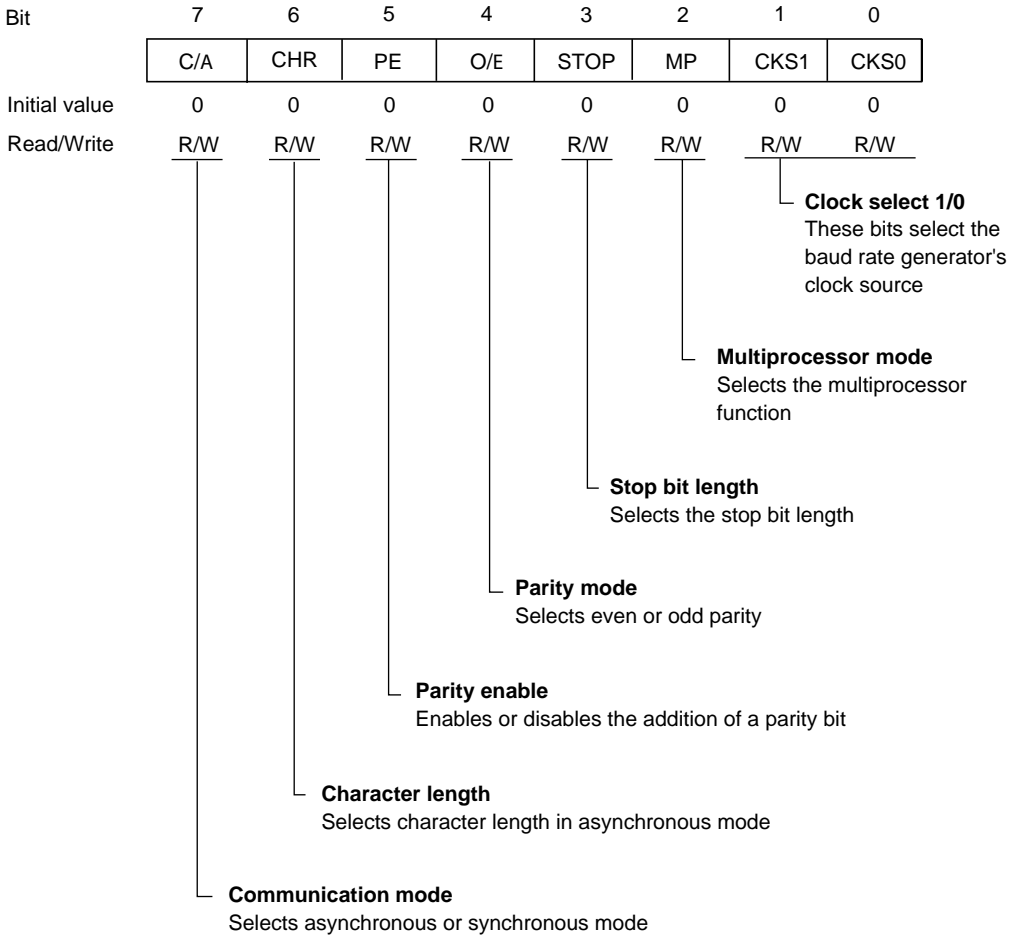

The CPU can always read and write SMR. SMR is initialized to H'00 by a reset and in standby mode.

Bit 7—Communication Mode (C/A)/GSM Mode (GM): The function of this bit differs for the normal serial communication interface and for the smart card interface. Its function is switched with the SMIF bit in SCMR.

For serial communication interface (SMIF bit in SCMR cleared to 0): Selects whether the SCI operates in asynchronous or synchronous mode.

Bit 7

C/A	Description	
0	Asynchronous mode	(Initial value)
1	Synchronous mode	

For smart card interface (SMIF bit in SCMR set to 1): Selects GSM mode for the smart card interface.

Bit 7

GM	Description	
0	The TEND flag is set 12.5 etu after the start bit	(Initial value)
1	The TEND flag is set 11.0 etu after the start bit	

Note: etu (Elementary time unit: the time for transfer of one bit)

Bit 6—Character Length (CHR): Selects 7-bit or 8-bits data length in asynchronous mode. In synchronous mode, the data length is 8 bits regardless of the CHR setting,

Bit 6

CHR	Description	
0	8-bit data	(Initial value)
1	7-bit data*	

Note: * When 7-bit data is selected, the MSB (bit 7) of TDR is not transmitted.

Bit 5—Parity Enable (PE): In asynchronous mode, this bit enables or disables the addition of a parity bit to transmit data, and the checking of the parity bit in receive data. In synchronous mode, the parity bit is neither added nor checked, regardless of the PE bit setting.

Bit 5

PE	Description	
0	Parity bit not added or checked	(Initial value)
1	Parity bit added and checked*	

Note: * When PE bit is set to 1, an even or odd parity bit is added to transmit data according to the even or odd parity mode selection by the O/\bar{E} bit, and the parity bit in receive data is checked to see that it matches the even or odd mode selected by the O/\bar{E} bit.

Bit 4—Parity Mode (O/\bar{E}): Selects even or odd parity. The O/\bar{E} bit setting is only valid when the PE bit is set to 1, enabling parity bit addition and checking, in asynchronous mode. The O/\bar{E} bit setting is ignored in synchronous mode, or when parity addition and checking is disabled in asynchronous mode.

Bit 4

O/\bar{E}	Description	
0	Even parity* ¹	(Initial value)
1	Odd parity* ²	

Notes: 1. When even parity is selected, the parity bit added to transmit data makes an even number of 1s in the transmitted character and parity bit combined. Receive data must have an even number of 1s in the received character and parity bit combined.
 2. When odd parity is selected, the parity bit added to transmit data makes an odd number of 1s in the transmitted character and parity bit combined. Receive data must have an odd number of 1s in the received character and parity bit combined.

Bit 3—Stop Bit Length (STOP): Selects one or two stop bits in asynchronous mode. This setting is used only in asynchronous mode. In synchronous mod no stop bit is added, so the STOP bit setting is ignored.

Bit 3

STOP	Description	
0	1 stop bit* ¹	(Initial value)
1	2 stop bits* ²	

Notes: 1. One stop bit (with value 1) is added to the end of each transmitted character.
 2. Two stop bits (with value 1) are added to the end of each transmitted character.

In receiving, only the first stop bit is checked, regardless of the STOP bit setting. If the second stop bit is 1, it is treated as a stop bit. If the second stop bit is 0, it is treated as the start bit of the next incoming character.

Bit 2—Multiprocessor Mode (MP): Selects a multiprocessor format. When a multiprocessor format is selected, parity settings made by the PE and O/E bits are ignored. The MP bit setting is valid only in asynchronous mode. It is ignored in synchronous mode.

For further information on the multiprocessor communication function, see section 13.3.3, Multiprocessor Communication.

Bit 2

MP	Description	
0	Multiprocessor function disabled	(Initial value)
1	Multiprocessor format selected	

Bits 1 and 0—Clock Select 1 and 0 (CKS1/0): These bits select the clock source for the on-chip baud rate generator. Four clock sources are available: ϕ , $\phi/4$, $\phi/16$, and $\phi/64$.

For the relationship between the clock source, bit rate register setting, and baud rate, see section 13.2.8, Bit Rate Register (BRR).

Bit 1 CKS1	Bit 0 CKS0	Description	
0	0	ϕ	(Initial value)
0	1	$\phi/4$	
1	0	$\phi/16$	
1	1	$\phi/64$	

13.2.6 Serial Control Register (SCR)

SCR register enables or disables the SCI transmitter and receiver, enables or disables serial clock output in asynchronous mode, enables or disables interrupts, and selects the transmit/receive clock source.

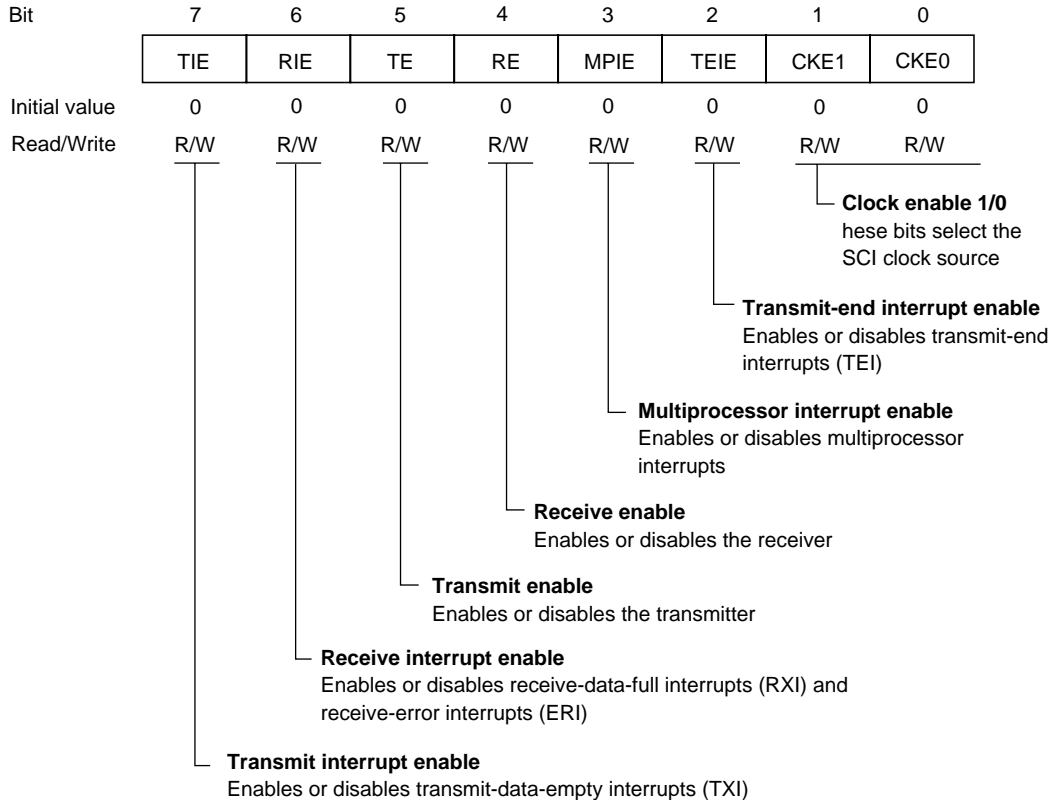

The CPU can always read and write SCR. SCR is initialized to H'00 by a reset and in standby mode.

Bit 7—Transmit Interrupt Enable (TIE): Enables or disables the transmit-data-empty interrupt (TXI) requested when the TDRE flag in SSR is set to 1 due to transfer of serial transmit data from TDR to TSR.

Bit 7

TIE	Description
0	Transmit-data-empty interrupt request (TXI) is disabled* (Initial value)
1	Transmit-data-empty interrupt request (TXI) is enabled

Note: * TXI interrupt requests can be cleared by reading the value 1 from the TDRE flag, then clearing it to 0; or by clearing the TIE bit to 0.

Bit 6—Receive Interrupt Enable (RIE): Enables or disables the receive-data-full interrupt (RXI) requested when the RDRF flag in SSR is set to 1 due to transfer of serial receive data from RSR to RDR; also enables or disables the receive-error interrupt (ERI).

Bit 6

RIE	Description
0	Receive-data-full (RXI) and receive-error (ERI) interrupt requests are disabled* (Initial value)
1	Receive-data-full (RXI) and receive-error (ERI) interrupt requests are enabled

Note: * RXI and ERI interrupt requests can be cleared by reading the value 1 from the RDRF, FER, PER, or ORER flag, then clearing the flag to 0; or by clearing the RIE bit to 0.

Bit 5—Transmit Enable (TE): Enables or disables the start of SCI serial transmitting operations.

Bit 5

TE	Description
0	Transmitting disabled* ¹ (Initial value)
1	Transmitting enabled* ²

Notes: 1. The TDRE flag is fixed at 1 in SSR.
 2. In the enabled state, serial transmission starts when the TDRE flag in SSR is cleared to 0 after writing of transmit data into TDR. Select the transmit format in SMR before setting the TE bit to 1.

Bit 4—Receive Enable (RE): Enables or disables the start of SCI serial receiving operations.

Bit 4 RE	Description
0	Receiving disabled* ¹ (Initial value)
1	Receiving enabled* ²

- Notes: 1. Clearing the RE bit to 0 does not affect the RDRF, FER, PER, and ORER flags. These flags retain their previous values.
2. In the enabled state, serial receiving starts when a start bit is detected in asynchronous mode, or serial clock input is detected in synchronous mode. Select the receive format in SMR before setting the RE bit to 1.

Bit 3—Multiprocessor Interrupt Enable (MPIE): Enables or disables multiprocessor interrupts. The MPIE bit setting is valid only in asynchronous mode, and only if the MP bit is set to 1 in SMR. The MPIE bit setting is ignored in synchronous mode or when the MP bit is cleared to 0.

Bit 3 MPIE	Description
0	Multiprocessor interrupts are disabled (normal receive operation)(Initial value) Clearing conditions (1) The MPIE bit is cleared to 0 (2) MPB = 1 in received data
1	Multiprocessor interrupts are enabled* Receive-data-full interrupts (RXI), receive-error interrupts (ERI), and setting of the RDRF, FER, and ORER status flags in SSR are disabled until data with the multiprocessor bit set to 1 is received.

Note: * The SCI does not transfer receive data from RSR to RDR, does not detect receive errors, and does not set the RDRF, FER, and ORER flags in SSR. When it receives data in which MPB = 1, the SCI sets the MPB bit to 1 in SSR, automatically clears the MPIE bit to 0, enables RXI and ERI interrupts (if the TIE and RIE bits in SCR are set to 1), and allows the FER and ORER flags to be set.

Bit 2—Transmit-End interrupt Enable (TEIE): Enables or disables the transmit-end interrupt (TEI) requested if TDR does not contain valid transmit data when the MSB is transmitted.

Bit 2 TEIE	Description	
0	Transmit-end interrupt requests (TEI) are disabled*	(Initial value)
1	Transmit-end interrupt requests (TEI) are enabled*	

Note: * TEI interrupt requests can be cleared by reading the value 1 from the TDRE flag in SSR, then clearing the TDRE flag to 0, thereby also clearing the TEND flag to 0; or by clearing the TEIE bit to 0.

Bits 1 and 0—Clock Enable 1 and 0 (CKE1/0): The function of these bits differs for the normal serial communication interface and for the smart card interface. Their function is switched with the SMIF bit in SCMR.

For serial communication interface (SMIF bit in SCMR cleared to 0): These bits select the SCI clock source and enable or disable clock output from the SCK pin. Depending on the settings of CKE1 and CKE0, the SCK pin can be used for generic input/output, serial clock output, or serial clock input.

The CKE0 setting is valid only in asynchronous mode, and only when the SCI is internally clocked (CKE1 = 0). The CKE0 setting is ignored in synchronous mode, or when an external clock source is selected (CKE1 = 1). Select the SCI operating mode in SMR before setting the CKE1 and CKE0 bits. For further details on selection of the SCI clock source, see table 13.9 in section 13.3, Operation.

Bit 1 CKE1	Bit 0 CKE0	Description	
0	0	Asynchronous mode	Internal clock, SCK pin available for generic input/output* ¹
		Synchronous mode	Internal clock, SCK pin used for serial clock output* ¹
0	1	Asynchronous mode	Internal clock, SCK pin used for clock output* ²
		Synchronous mode	Internal clock, SCK pin used for serial clock output
1	0	Asynchronous mode	External clock, SCK pin used for clock input* ³
		Synchronous mode	External clock, SCK pin used for serial clock input
1	1	Asynchronous mode	External clock, SCK pin used for clock input* ³
		Synchronous mode	External clock, SCK pin used for serial clock input

- Notes: 1. Initial value
 2. The output clock frequency is the same as the bit rate.
 3. The input clock frequency is 16 times the bit rate.

For smart card interface (SMIF bit in SCMR set to 1): These bits, together with the GM bit in SMR, determine whether the SCK pin is used for generic input/output or as the serial clock output pin.

SMR GM	Bit 1 CKE1	Bit 0 CKE0	Description	
0	0	0	SCK pin available for generic input/output	(Initial value)
0	0	1	SCK pin used for clock output	
1	0	0	SCK pin output fixed low	
1	0	1	SCK pin used for clock output	
1	1	0	SCK pin output fixed high	
1	1	1	SCK pin used for clock output	

13.2.7 Serial Status Register (SSR)

SSR is an 8-bit register containing multiprocessor bit values, and status flags that indicate the operating status of the SCI.

Bit	7	6	5	4	3	2	1	0
	TDRE	RDRF	ORER	FER/ERS	PER	TEND	MPB	MPBT
Initial value	1	0	0	0	0	1	0	0
Read/Write	R/(W)*1	R/(W)*1	R/(W)*1	R/(W)*1	R/(W)*1	R	R	R/W

Multiprocessor bit transfer
Value of multiprocessor bit to be transmitted

Multiprocessor bit
Stores the received multiprocessor bit value

Transmit end*2
Status flag indicating end of transmission

Parity error
Status flag indicating detection of a receive parity error

Framing error (FER)/Error signal status (ERS)*2
Status flag indicating detection of a receive framing error, or flag indicating detection of an error signal

Overrun error
Status flag indicating detection of a receive overrun error

Receive data register full
Status flag indicating that data has been received and stored in RDR

Transmit data register empty
Status flag indicating that transmit data has been transferred from TDR into TSR and new data can be written in TDR

Notes: 1. Only 0 can be written, to clear the flag.

2. Function differs between the normal serial communication interface and the smart card interface.

The CPU can always read and write SSR, but cannot write 1 in the TDRE, RDRF, ORER, PER, and FER flags. These flags can be cleared to 0 only if they have first been read while set to 1. The TEND and MPB flags are read-only bits that cannot be written.

SSR is initialized to H'84 by a reset and in standby mode.

Bit 7—Transmit Data Register Empty (TDRE): Indicates that the SCI has loaded transmit data from TDR into TSR and the next serial data can be written in TDR.

Bit 7 TDRE	Description
0	TDR contains valid transmit data Clearing conditions Read TDRE when TDRE = 1, then write 0 in TDRE The DMAC writes data in TDR
1	TDR does not contain valid transmit data (Initial value) Setting conditions The chip is reset or enters standby mode The TE bit in SCR is cleared to 0 TDR contents are loaded into TSR, so new data can be written in TDR

Bit 6—Receive Data Register Full (RDRF): Indicates that RDR contains new receive data.

Bit 6 RDRF	Description
0	RDR does not contain new receive data (Initial value) Clearing conditions The chip is reset or enters standby mode Read RDRF when RDRF = 1, then write 0 in RDRF The DMAC reads data from RDR
1	RDR contains new receive data Setting condition Serial data is received normally and transferred from RSR to RDR

Note: The RDR contents and the RDRF flag are not affected by detection of receive errors or by clearing of the RE bit to 0 in SCR. They retain their previous values. If the RDRF flag is still set to 1 when reception of the next data ends, an overrun error will occur and the receive data will be lost.

Bit 5—Overrun Error (ORER): Indicates that data reception ended abnormally due to an overrun error.

Bit 5 ORER	Description
0	Receiving is in progress or has ended normally* ¹ (Initial value) Clearing conditions The chip is reset or enters standby mode Read ORER when ORER = 1, then write 0 in ORER
1	A receive overrun error occurred* ² Setting condition Reception of the next serial data ends when RDRF = 1

- Notes:
1. Clearing the RE bit to 0 in SCR does not affect the ORER flag, which retains its previous value.
 2. RDR continues to hold the receive data prior to the overrun error, so subsequent receive data is lost. Serial receiving cannot continue while the ORER flag is set to 1. In synchronous mode, serial transmitting is also disabled.

Bit 4—Framing Error (FER)/Error Signal Status (ERS): The function of this bit differs for the normal serial communication interface and for the smart card interface. Its function is switched with the SMIF bit in SCMR.

For serial communication interface (SMIF bit in SCMR cleared to 0): Indicates that data reception ended abnormally due to a framing error in asynchronous mode.

Bit 4 FER	Description
0	Receiving is in progress or has ended normally* ¹ (Initial value) Clearing conditions The chip is reset or enters standby mode Read FER when FER = 1, then write 0 in FER
1	A receive framing error occurred* ² Setting condition The stop bit at the end of the receive data is checked and found to be 0

- Notes:
1. Clearing the RE bit to 0 in SCR does not affect the FER flag, which retains its previous value.
 2. When the stop bit length is 2 bits, only the first bit is checked. The second stop bit is not checked. When a framing error occurs the SCI transfers the receive data into RDR but does not set the RDRF flag. Serial receiving cannot continue while the FER flag is set to 1. In synchronous mode, serial transmitting is also disabled.

For smart card interface (SMIF bit in SCMR set to 1): Indicates the status of the error signal sent back from the receiving side during transmission. Framing errors are not detected in smart card interface mode.

Bit 4

ERS	Description	
0	Normal reception, no error signal* Clearing conditions The chip is reset or enters standby mode Read ERS when ERS = 1, then write 0 in ERS	(Initial value)
1	An error signal has been sent from the receiving side indicating detection of a parity error Setting condition The error signal is low when sampled	

Note: * Clearing the TE bit to 0 in SCR does not affect the ERS flag, which retains its previous value.

Bit 3—Parity Error (PER): Indicates that data reception ended abnormally due to a parity error in asynchronous mode.

Bit 3

PER	Description	
0	Receiving is in progress or has ended normally* ¹ Clearing conditions The chip is reset or enters standby mode Read PER when PER = 1, then write 0 in PER	(Initial value)
1	A receive parity error occurred* ² Setting condition The number of 1s in receive data, including the parity bit, does not match the even or odd parity setting of O/ \bar{E} in SMR	

Notes: 1. Clearing the RE bit to 0 in SCR does not affect the PER flag, which retains its previous value.

2. When a parity error occurs the SCI transfers the receive data into RDR but does not set the RDRF flag. Serial receiving cannot continue while the PER flag is set to 1. In asynchronous mode, serial transmitting is also disabled.

Bit 2—Transmit End (TEND): The function of this bit differs for the normal serial communication interface and for the smart card interface. Its function is switched with the SMIF bit in SCMR.

For serial communication interface (SMIF bit in SCMR cleared to 0): Indicates that when the last bit of a serial character was transmitted TDR did not contain valid transmit data, so transmission has ended. The TEND flag is a read-only bit and cannot be written.

Bit 2

TEND	Description
0	Transmission is in progress Clearing conditions Read TDRE when TDRE = 1, then write 0 in TDRE The DMAC writes data in TDR
1	End of transmission (Initial value) Setting conditions The chip is reset or enters standby mode The TE bit in SCR is cleared to 0 TDRE is 1 when the last bit of a 1-byte serial transmit character is transmitted

For smart card interface (SMIF bit in SCMR set to 1): Indicates that when the last bit of a serial character was transmitted TDR did not contain valid transmit data, so transmission has ended. The TEND flag is a read-only bit and cannot be written.

Bit 2

TEND	Description
0	Transmission is in progress Clearing conditions Read TDRE when TDRE = 1, then write 0 in TDRE The DMAC writes data in TDR
1	End of transmission (Initial value) Setting conditions The chip is reset or enters standby mode The TE bit is cleared to 0 in SCR and the FER/ERS bit is also cleared to 0 TDRE is 1 and FER/ERS is 0 (normal transmission) 2.5 etu (when GM = 0) or 1.0 etu (when GM = 1) after a 1-byte serial character is transmitted

Note: etu (Elementary time unit: the time for transfer of one bit)

Bit 1—Multiprocessor bit (MPB): Stores the value of the multiprocessor bit in the receive data when a multiprocessor format is used in asynchronous mode. MPB is a read-only bit, and cannot be written.

Bit 1 MPB	Description
0	Multiprocessor bit value in receive data is 0* (Initial value)
1	Multiprocessor bit value in receive data is 1

Note: * If the RE bit in SCR is cleared to 0 when a multiprocessor format is selected, MPB retains its previous value.

Bit 0—Multiprocessor Bit Transfer (MPBT): Stores the value of the multiprocessor bit added to transmit data when a multiprocessor format in selected for transmitting in asynchronous mode.

The MPBT bit setting is ignored in synchronous mode, when a multiprocessor format is not selected, or when the SCI cannot transmit.

Bit 1 MPBT	Description
0	Multiprocessor bit value in transmit data is 0 (Initial value)
1	Multiprocessor bit value in transmit data is 1

13.2.8 Bit Rate Register (BRR)

BRR is an 8-bit register that., together with the CKS1 and CKS0 bits in SMR that select the baud rate generator clock source, determines the serial communication bit rate.

Bit	7	6	5	4	3	2	1	0
Initial value	1	1	1	1	1	1	1	1
Read/Write	R/W	R/W	R/W	R/W	R/W	R/W	R/W	R/W

The CPU can always read and write BRR. BRR is initialized to H'FF by a reset and in standby mode. Each SCI channel has independent baud rate generator control, so different values can be set in the three channels.

Table 13.3 shows examples of BRR settings in asynchronous mode. Table 13.4 shows examples of BRR settings in synchronous mode.

Table 13.3 Examples of Bit Rates and BRR Settings in Asynchronous Mode

Bit Rate (bit/s)	ϕ (MHz)											
	2			2.097152			2.4576			3		
	n	N	Error (%)	n	N	Error (%)	n	N	Error (%)	n	N	Error (%)
110	1	141	0.03	1	148	-0.04	1	174	-0.26	1	212	0.03
150	1	103	0.16	1	108	0.21	1	127	0.00	1	155	0.16
300	0	207	0.16	0	217	0.21	0	255	0.00	1	77	0.16
600	0	103	0.16	0	108	0.21	0	127	0.00	0	155	0.16
1200	0	51	0.16	0	54	-0.70	0	63	0.00	0	77	0.16
2400	0	25	0.16	0	26	1.14	0	31	0.00	0	38	0.16
4800	0	12	0.16	0	13	-2.48	0	15	0.00	0	19	-2.34
9600	0	6	-6.99	0	6	-2.48	0	7	0.00	0	9	-2.34
19200	0	2	8.51	0	2	13.78	0	3	0.00	0	4	-2.34
31250	0	1	0.00	0	1	4.86	0	1	22.88	0	2	0.00
38400	0	1	-18.62	0	1	-14.67	0	1	0.00	—	—	—

Bit Rate (bit/s)	ϕ (MHz)											
	3.6864			4			4.9152			5		
	n	N	Error (%)	n	N	Error (%)	n	N	Error (%)	n	N	Error (%)
110	2	64	0.70	2	70	0.03	2	86	0.31	2	88	-0.25
150	1	191	0.00	1	207	0.16	1	255	0.00	2	64	0.16
300	1	95	0.00	1	103	0.16	1	127	0.00	1	129	0.16
600	0	191	0.00	0	207	0.16	0	255	0.00	1	64	0.16
1200	0	95	0.00	0	103	0.16	0	127	0.00	0	129	0.16
2400	0	47	0.00	0	51	0.16	0	63	0.00	0	64	0.16
4800	0	23	0.00	0	25	0.16	0	31	0.00	0	32	-1.36
9600	0	11	0.00	0	12	0.16	0	15	0.00	0	15	1.73
19200	0	5	0.00	0	6	-6.99	0	7	0.00	0	7	1.73
31250	—	—	—	0	3	0.00	0	4	-1.70	0	4	0.00
38400	0	2	0.00	0	2	8.51	0	3	0.00	0	3	1.73

Bit Rate (bit/s)	ϕ (MHz)											
	6			6.144			7.3728			8		
	n	N	Error (%)	n	N	Error (%)	n	N	Error (%)	n	N	Error (%)
110	2	106	-0.44	2	108	0.08	2	130	-0.07	2	141	0.03
150	2	77	0.16	2	79	0.00	2	95	0.00	2	103	0.16
300	1	155	0.16	1	159	0.00	1	191	0.00	1	207	0.16
600	1	77	0.16	1	79	0.00	1	95	0.00	1	103	0.16
1200	0	155	0.16	0	159	0.00	0	191	0.00	0	207	0.16
2400	0	77	0.16	0	79	0.00	0	95	0.00	0	103	0.16
4800	0	38	0.16	0	39	0.00	0	47	0.00	0	51	0.16
9600	0	19	-2.34	0	19	0.00	0	23	0.00	0	25	0.16
19200	0	9	-2.34	0	9	0.00	0	11	0.00	0	12	0.16
31250	0	5	0.00	0	5	2.40	0	6	5.33	0	7	0.00
38400	0	4	-2.34	0	4	0.00	0	5	0.00	0	6	-6.99

Bit Rate (bit/s)	ϕ (MHz)											
	9.8304			10			12			12.288		
	n	N	Error (%)	n	N	Error (%)	n	N	Error (%)	n	N	Error (%)
110	2	174	-0.26	2	177	-0.25	2	212	0.03	2	217	0.08
150	2	127	0.00	2	129	0.16	2	155	0.16	2	159	0.00
300	1	255	0.00	2	64	0.16	2	77	0.16	2	79	0.00
600	1	127	0.00	1	129	0.16	1	155	0.16	1	159	0.00
1200	0	255	0.00	1	64	0.16	1	77	0.16	1	79	0.00
2400	0	127	0.00	0	129	0.16	0	155	0.16	0	159	0.00
4800	0	63	0.00	0	64	0.16	0	77	0.16	0	79	0.00
9600	0	31	0.00	0	32	-1.36	0	38	0.16	0	39	0.00
19200	0	15	0.00	0	15	1.73	0	19	-2.34	0	19	0.00
31250	0	9	-1.70	0	9	0.00	0	11	0.00	0	11	2.40
38400	0	7	0.00	0	7	1.73	0	9	-2.34	0	9	0.00

ϕ (MHz)

Bit Rate (bit/s)	13			14			14.7456			16			18			20		
	n	N	Error (%)	n	N	Error (%)	n	N	Error (%)	n	N	Error (%)	n	N	Error (%)	n	N	Error (%)
110	2	230	-0.08	2	248	-0.17	3	64	0.70	3	70	0.03	3	79	-0.12	3	88	-0.25
150	2	168	0.16	2	181	0.16	2	191	0.00	2	207	0.16	2	233	0.16	3	64	0.16
300	2	84	-0.43	2	90	0.16	2	95	0.00	2	103	0.16	2	116	0.16	2	129	0.16
600	1	168	0.16	1	181	0.16	1	191	0.00	1	207	0.16	1	233	0.16	2	64	0.16
1200	1	84	-0.43	1	90	0.16	1	95	0.00	1	103	0.16	1	116	0.16	1	129	0.16
2400	0	168	0.16	0	181	0.16	0	191	0.00	0	207	0.16	0	233	0.16	1	64	0.16
4800	0	84	-0.43	0	90	0.16	0	95	0.00	0	103	0.16	0	116	0.16	0	129	0.16
9600	0	41	0.76	0	45	-0.93	0	47	0.00	0	51	0.16	0	58	-0.69	0	64	0.16
19200	0	20	0.76	0	22	-0.93	0	23	0.00	0	25	0.16	0	28	1.02	0	32	-1.36
31250	0	12	0.00	0	13	0.00	0	14	-1.70	0	15	0.00	0	17	0.00	0	19	0.00
38400	0	10	-3.82	0	10	3.57	0	11	0.00	0	12	0.16	0	14	-2.34	0	15	1.73

Table 13.4 Examples of Bit Rates and BRR Settings in Synchronous Mode

Bit Rate (bit/s)	ϕ (MHz)															
	2		4		8		10		13		16		18		20	
	n	N	n	N	n	N	n	N	n	N	n	N	n	N	n	N
110	3	70	—	—	—	—	—	—	—	—	—	—	—	—	—	—
250	2	124	2	249	3	124	—	—	3	202	3	249	—	—	—	—
500	1	249	2	124	2	249	—	—	3	101	3	124	3	140	3	155
1k	1	124	1	249	2	124	—	—	2	202	2	249	3	69	3	77
2.5k	0	199	1	99	1	199	1	249	2	80	2	99	2	112	2	124
5k	0	99	0	199	1	99	1	124	1	162	1	199	1	224	1	249
10k	0	49	0	99	0	199	0	249	1	80	1	99	1	112	1	124
25k	0	19	0	39	0	79	0	99	0	129	0	159	0	179	0	199
50k	0	9	0	19	0	39	0	49	0	64	0	79	0	89	0	99
100k	0	4	0	9	0	19	0	24	—	—	0	39	0	44	0	49
250k	0	1	0	3	0	7	0	9	0	12	0	15	0	17	0	19
500k	0	0*	0	1	0	3	0	4	—	—	0	7	0	8	0	9
1M			0	0*	0	1	—	—	—	—	0	3	0	4	0	4
2M					0	0*	—	—	—	—	0	1	—	—	—	—
2.5M					—	—	0	0*	—	—	—	—	—	—	—	—
4M											0	0*	—	—	—	—

Note: Settings with an error of 1% or less are recommended.

Legend

Blank : No setting available

— : Setting possible, but error occurs

* : Continuous transmission/reception not possible

The BRR setting is calculated as follows:

Asynchronous mode:

$$N = \frac{\phi}{64 \times 2^{2n-1} \times B} \times 10^6 - 1$$

Synchronous mode:

$$N = \frac{\phi}{8 \times 2^{2n-1} \times B} \times 10^6 - 1$$

B: Bit rate (bit/s)

N: BRR setting for baud rate generator ($0 \leq N \leq 255$)

ϕ : System clock frequency (MHz)

n: Baud rate generator clock source ($n = 0, 1, 2, 3$)

(For the clock sources and values of n, see the following table.)

n	Clock Source	SMR Settings	
		CKS1	CKS0
0	ϕ	0	0
1	$\phi/4$	0	1
2	$\phi/16$	1	0
3	$\phi/64$	1	1

The bit rate error in asynchronous mode is calculated as follows:

$$\text{Error (\%)} = \left\{ \frac{\phi \times 10^6}{(N + 1) \times B \times 64 \times 2^{2n-1}} - 1 \right\} \times 100$$

Table 13.5 shows the maximum bit rates in asynchronous mode for various system clock frequencies. Table 13.6 and 13.7 shows the maximum bit rates with external clock input.

Table 13.5 Maximum Bit Rates for Various Frequencies (Asynchronous Mode)

ϕ (MHz)	Maximum Bit Rate (bit/s)	Settings	
		n	N
2	62500	0	0
2.097152	65536	0	0
2.4576	76800	0	0
3	93750	0	0
3.6864	115200	0	0
4	125000	0	0
4.9152	153600	0	0
5	156250	0	0
6	187500	0	0
6.144	192000	0	0
7.3728	230400	0	0
8	250000	0	0
9.8304	307200	0	0
10	312500	0	0
12	375000	0	0
12.288	384000	0	0
14	437500	0	0
14.7456	460800	0	0
16	500000	0	0
17.2032	537600	0	0
18	562500	0	0
20	625000	0	0

Table 13.6 Maximum Bit Rates with External Clock Input (Asynchronous Mode)

ϕ (MHz)	External Input Clock (MHz)	Maximum Bit Rate (bit/s)
2	0.5000	31250
2.097152	0.5243	32768
2.4576	0.6144	38400
3	0.7500	46875
3.6864	0.9216	57600
4	1.0000	62500
4.9152	1.2288	76800
5	1.2500	78125
6	1.5000	93750
6.144	1.5360	96000
7.3728	1.8432	115200
8	2.0000	125000
9.8304	2.4576	153600
10	2.5000	156250
12	3.0000	187500
12.288	3.0720	192000
14	3.5000	218750
14.7456	3.6864	230400
16	4.0000	250000
17.2032	4.3008	268800
18	4.5000	281250
20	5.0000	312500

Table 13.7 Maximum Bit Rates with External Clock Input (Synchronous Mode)

ϕ (MHz)	External Input Clock (MHz)	Maximum Bit Rate (bit/s)
2	0.3333	333333.3
4	0.6667	666666.7
6	1.0000	1000000.0
8	1.3333	1333333.3
10	1.6667	1666666.7
12	2.0000	2000000.0
14	2.3333	2333333.3
16	2.6667	2666666.7
18	3.0000	3000000.0
20	3.3333	3333333.3

13.3 Operation

13.3.1 Overview

The SCI can carry out serial communication in two modes: asynchronous mode in which synchronization is achieved character by character, and synchronous mode in which synchronization is achieved with clock pulses. A smart card interface is also supported as a serial communication function for an IC card interface.

Selection of asynchronous or synchronous mode and the transmission format for the normal serial communication interface is made in SMR, as shown in table 13.8. The SCI clock source is selected by the C/\bar{A} bit in SMR and the CKE1 and CKE0 bits in SCR, as shown in table 13.9.

For details of the procedures for switching between LSB-first and MSB-first mode and inverting the data logic level, see section 14.2.1, Smart Card Mode Register (SCMR).

For selection of the smart card interface format, see section 14.3.3, Data Format.

Asynchronous Mode

- Data length is selectable: 7 or 8 bits
- Parity and multiprocessor bits are selectable, and so is the stop bit length (1 or 2 bits). These selections determine the communication format and character length.
- In receiving, it is possible to detect framing errors, parity errors, overrun errors, and the break state.
- An internal or external clock can be selected as the SCI clock source.
 - When an internal clock is selected, the SCI operates using the on-chip baud rate generator, and can output a serial clock signal with a frequency matching the bit rate.
 - When an external clock is selected, the external clock input must have a frequency 16 times the bit rate. (The on-chip baud rate generator is not used.)

Synchronous Mode

- The communication format has a fixed 8-bit data length.
- In receiving, it is possible to detect overrun errors.
- An internal or external clock can be selected as the SCI clock source.
 - When an internal clock is selected, the SCI operates using the on-chip baud rate generator, and can output a serial clock signal to external devices.
 - When an external clock is selected, the SCI operates on the input serial clock. The on-chip baud rate generator is not used.

Smart Card Interface

- One frame consists of 8-bit data and a parity bit.
- In transmitting, a guard time of at least two elementary time units (2 etu) is provided between the end of the parity bit and the start of the next frame. (An elementary time unit is the time required to transmit one bit.)
- In receiving, if a parity error is detected, a low error signal level is output for 1 etu, beginning 10.5 etu after the start bit.
- In transmitting, if an error signal is received, the same data is automatically transmitted again after at least 2 etu.
- Only asynchronous communication is supported. There is no synchronous communication function.

For details of smart card interface operation, see section 14, Smart Card Interface.

Table 13.8 SMR Settings and Serial Communication Formats

SMR Settings						SCI Communication Format				
Bit 7 C/ \bar{A}	Bit 6 CHR	Bit 2 MP	Bit 5 PE	Bit 3 STOP	Mode	Data Length	Multi-processor Bit	Parity Bit	Stop Bit Length	
0	0	0	0	0	Asynchronous mode	8-bit data	Absent	Absent	1 bit	
				1					2 bits	
				0					1 bit	
				1					2 bits	
				1	7-bit data				Absent	1 bit
				0					2 bits	
				1					1 bit	
				0					2 bits	
				1					1 bit	
				0					2 bits	
1	1	—	—	0	Asynchronous mode (multi-processor format)	7-bit data	Present	Absent	1 bit	
				1					2 bits	
				0					1 bit	
				1					2 bits	
1	—	—	—	—	Synchronous mode	8-bit data	Absent		None	

Table 13.9 SMR and SCR Settings and SCI Clock Source Selection

SMR Bit 7 C/A	SCR Setting			SCI Transmit/Receive clock	
	Bit 1 CKE1	Bit 0 CKE0	Mode	Clock Source	SCK Pin Function
0	0	0	Asynchronous mode	Internal	SCI does not use the SCK pin
		1			Outputs clock with frequency matching the bit rate
	1	0		External	Inputs clock with frequency 16 times the bit rate
		1			
1	0	0	Synchronous mode	Internal	Outputs the serial clock
		1			
	1	0		External	Inputs the serial clock
		1			

13.3.2 Operation in Asynchronous Mode

In asynchronous mode, each transmitted or received character begins with a start bit and ends with one or two stop bits. Serial communication is synchronized one character at a time.

The transmitting and receiving sections of the SCI are independent, so full-duplex communication is possible. The transmitter and the receiver are both double-buffered, so data can be written and read while transmitting and receiving are in progress, enabling continuous transmitting and receiving.

Figure 13.2 shows the general format of asynchronous serial communication. In asynchronous serial communication the communication line is normally held in the mark (high) state. The SCI monitors the line and starts serial communication when the line goes to the space (low) state, indicating a start bit. One serial character consists of a start bit (low), data (LSB first), parity bit (high or low), and one or two stop bits (high), in that order.

When receiving in asynchronous mode, the SCI synchronizes at the falling edge of the start bit. The SCI samples each data bit on the eighth pulse of a clock with a frequency 16 times the bit rate. Receive data is latched at the center of each bit.

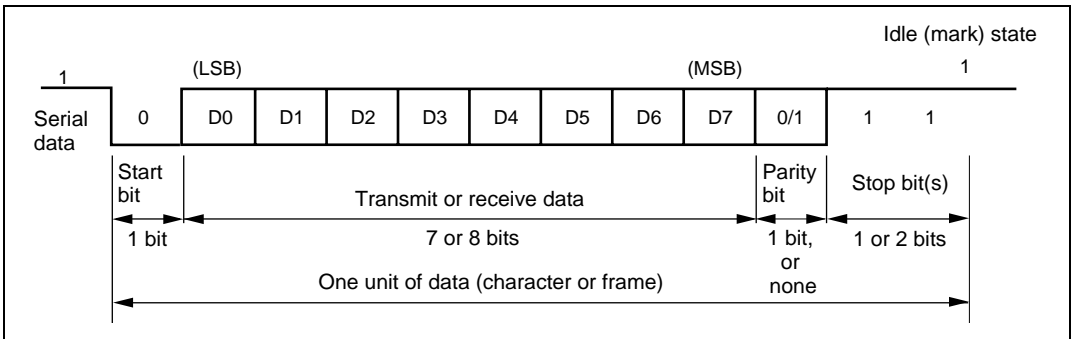

Figure 13.2 Data Format in Asynchronous Communication
(Example: 8-Bit Data with Parity and 2 Stop Bits)

Communication Formats: Table 13.10 shows the 12 communication formats that can be selected in asynchronous mode. The format is selected by settings in SMR.

Table 13.10 Serial Communication Formats (Asynchronous Mode)

SMR Settings				Serial Communication Format and Frame Length														
CHR	PE	MP	STOP	1	2	3	4	5	6	7	8	9	10	11	12			
0	0	0	0	S	8-bit data								STOP					
0	0	0	1	S	8-bit data								STOP	STOP				
0	1	0	0	S	8-bit data									P	STOP			
0	1	0	1	S	8-bit data									P	STOP	STOP		
1	0	0	0	S	7-bit data							STOP						
1	0	0	1	S	7-bit data							STOP	STOP					
1	1	0	0	S	7-bit data								P	STOP				
1	1	0	1	S	7-bit data								P	STOP	STOP			
0	—	1	0	S	8-bit data									MPB	STOP			
0	—	1	1	S	8-bit data									MPB	STOP	STOP		
1	—	1	0	S	7-bit data								MPB	STOP				
1	—	1	1	S	7-bit data								MPB	STOP	STOP			

Legend

S: Start bit

STOP: Stop bit

P: Parity bit

MPB: Multiprocessor bit

Clock: An internal clock generated by the on-chip baud rate generator or an external clock input from the SCK pin can be selected as the SCI transmit/receive clock. The clock source is selected by the C/A bit in SMR and bits CKE1 and CKE0 in SCR. For details of SCI clock source selection, see table 13.9.

When an external clock is input at the SCK pin, it must have a frequency 16 times the desired bit rate.

When the SCI is operated on an internal clock, it can output a clock signal at the SCK pin. The frequency of this output clock is equal to the bit rate. The phase is aligned as shown in figure 13.3 so that the rising edge of the clock occurs at the center of each transmit data bit.

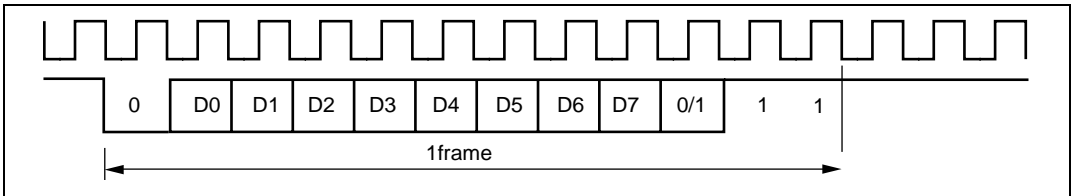

Figure 13.3 Phase Relationship between Output Clock and Serial Data (Asynchronous Mode)

Transmitting and Receiving Data:

- **SCI Initialization (Asynchronous Mode):** Before transmitting or receiving data, clear the TE and RE bits to 0 in SCR, then initialize the SCI as follows.

When changing the communication mode or format, always clear the TE and RE bits to 0 before following the procedure given below. Clearing TE to 0 sets the TDRE flag to 1 and initializes TSR. Clearing RE to 0, however, does not initialize the RDRF, PER, FER, and ORER flags, or RDR, which retain their previous contents.

When an external clock is used the clock should not be stopped during initialization or subsequent operation, since operation will be unreliable in this case.

Figure 13.4 shows a sample flowchart for initializing the SCI.

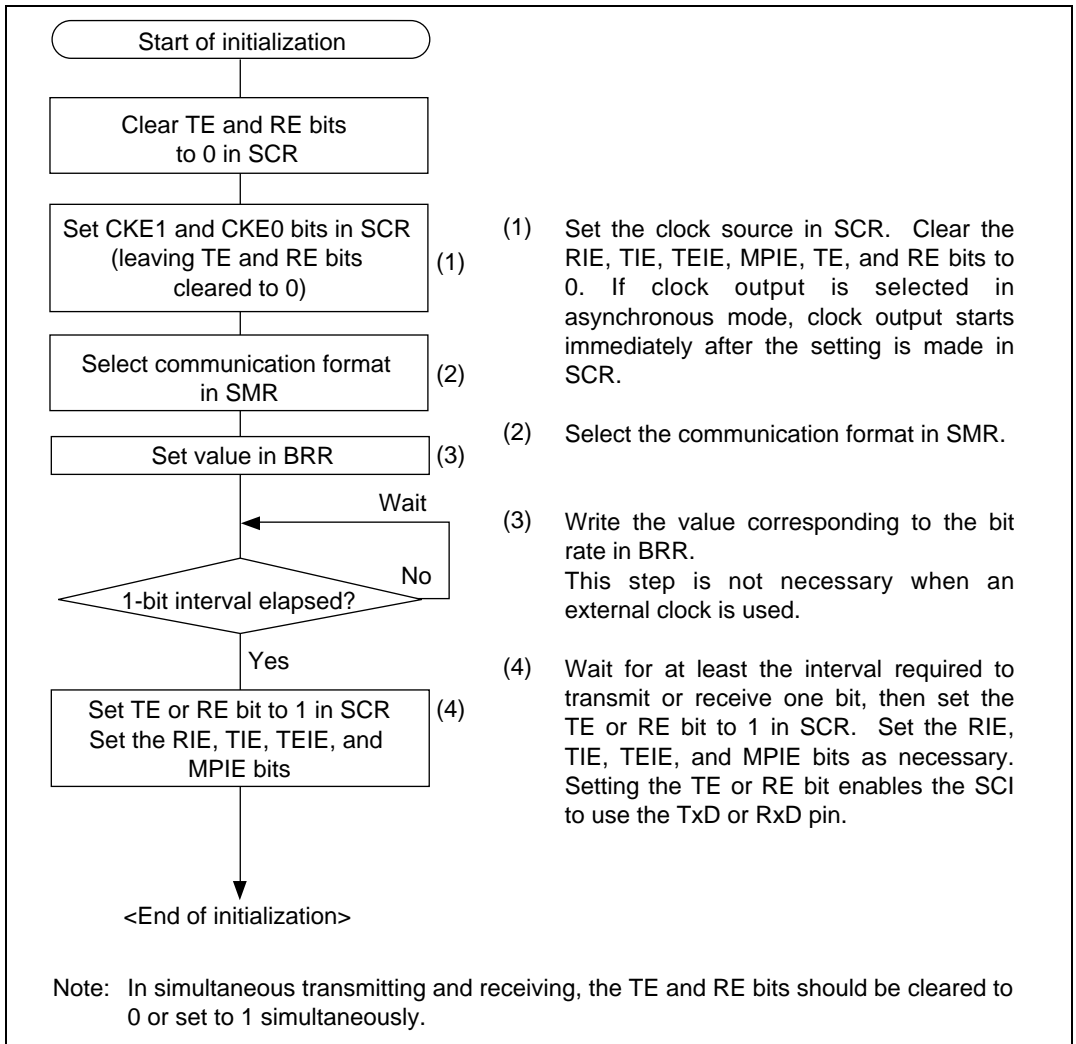

Figure 13.4 Sample Flowchart for SCI Initialization

- Transmitting Serial Data (Asynchronous Mode): Figure 13.5 shows a sample flowchart for transmitting serial data and indicates the procedure to follow.

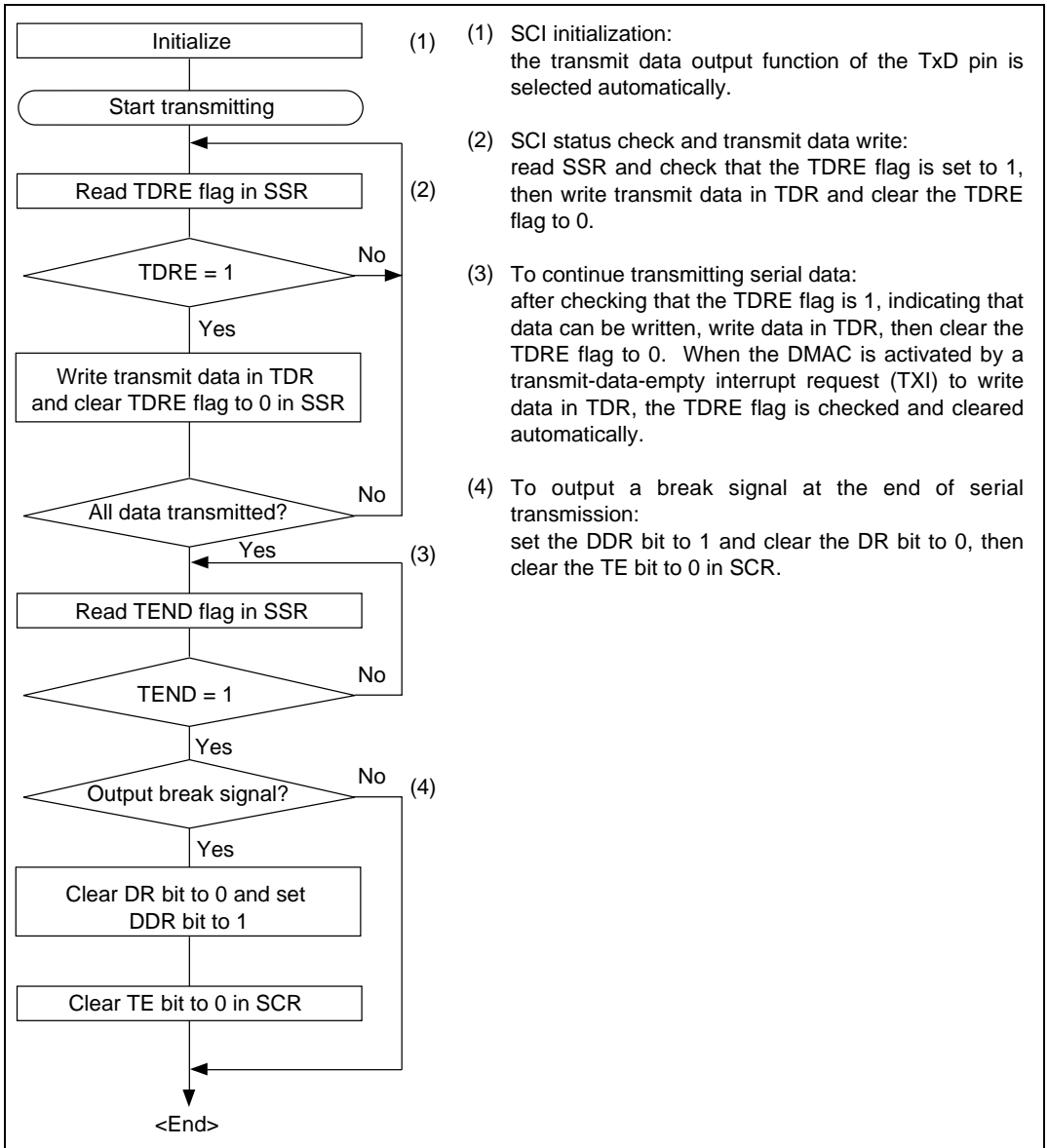

Figure 13.5 Sample Flowchart for Transmitting Serial Data

In transmitting serial data, the SCI operates as follows:

- The SCI monitors the TDRE flag in SSR. When the TDRE flag is cleared to 0, the SCI recognizes that TDR contains new data, and loads this data from TDR into TSR.
- After loading the data from TDR to TSR, the SCI sets the TDRE flag to 1 and starts transmitting. If the TIE bit is set to 1 in SCR, the SCI requests a transmit-data-empty interrupt (TXI) at this time.

Serial transmit data is transmitted in the following order from the TxD pin:

- Start bit: One 0 bit is output.
 - Transmit data: 7 or 8 bits are output, LSB first.
 - Parity bit or multiprocessor bit: One parity bit (even or odd parity), or one multiprocessor bit is output. Formats in which neither a parity bit nor a multiprocessor bit is output can also be selected.
 - Stop bit(s): One or two 1 bits (stop bits) are output.
 - Mark state: Output of 1 bits continues until the start bit of the next transmit data.
- The SCI checks the TDRE flag when it outputs the stop bit. If the TDRE flag is 0, the SCI loads new data from TDR into TSR, outputs the stop bit, then begins serial transmission of the next frame. If the TDRE flag is 1, the SCI sets the TEND flag to 1 in SSR, outputs the stop bit, then continues output of 1 bits in the mark state. If the TEIE bit is set to 1 in SCR, a transmit-end interrupt (TEI) is requested at this time

Figure 13.6 shows an example of SCI transmit operation in asynchronous mode.

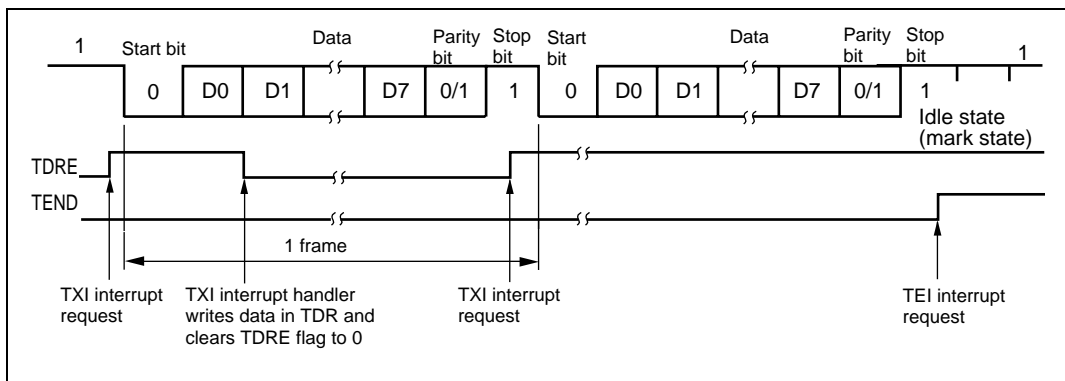

Figure 13.6 Example of SCI Transmit Operation in Asynchronous Mode (8-Bit Data with Parity and One Stop Bit)

- Receiving Serial Data (Asynchronous Mode): Figure 13.7 shows a sample flowchart for receiving serial data and indicates the procedure to follow.

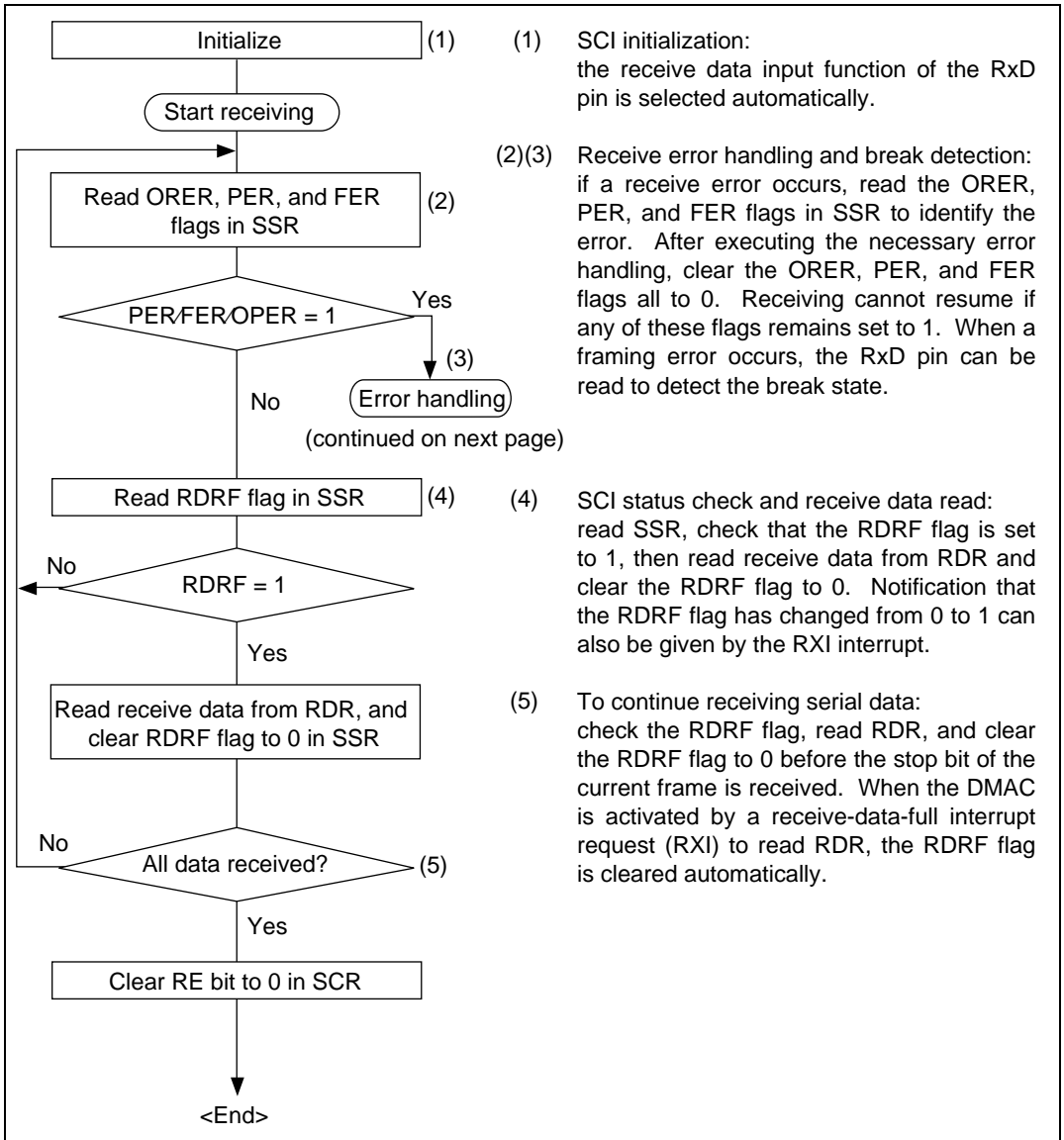

Figure 13.7 Sample Flowchart for Receiving Serial Data (1)

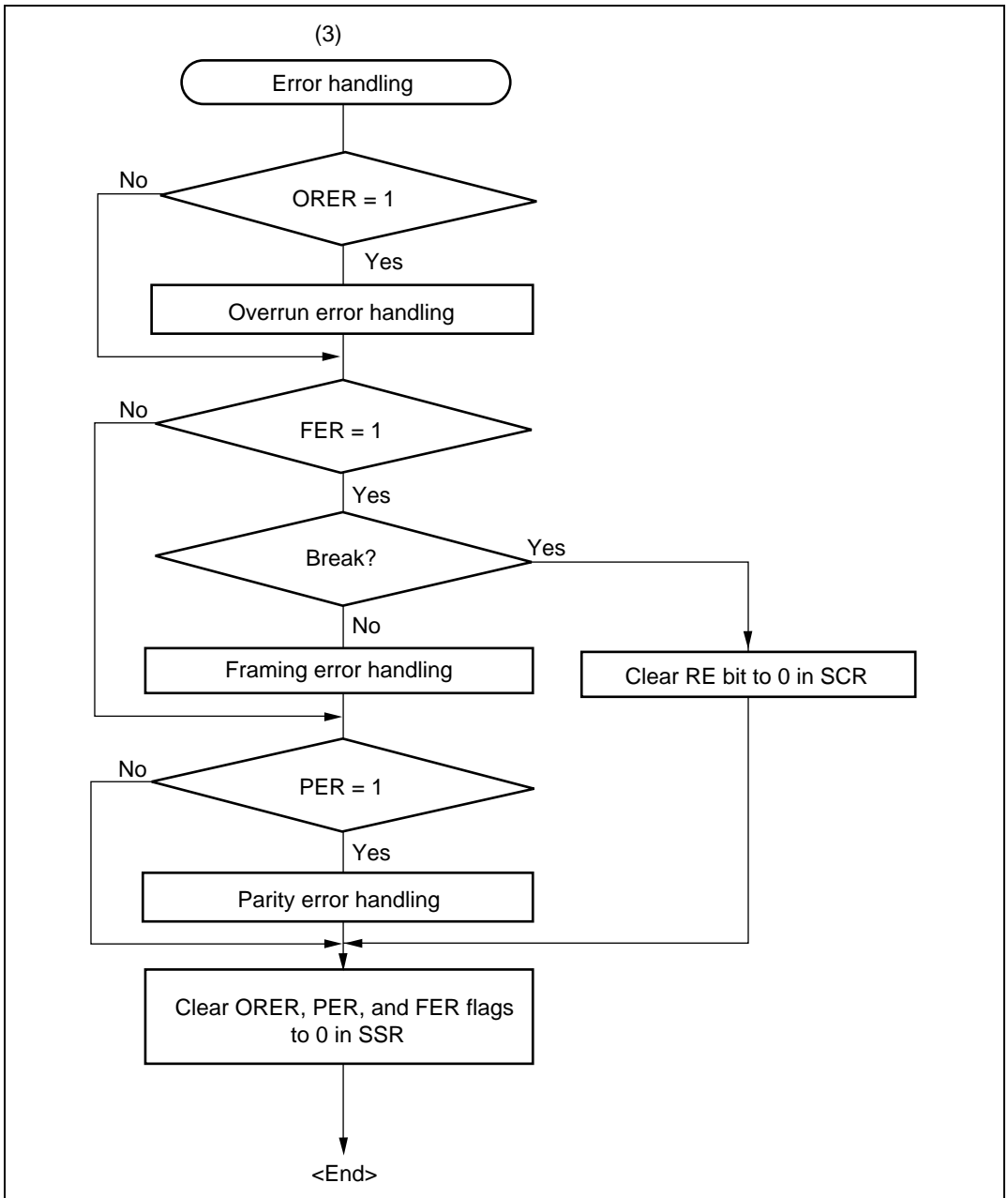

Figure 13.7 Sample Flowchart for Receiving Serial Data (2)

In receiving, the SCI operates as follows:

- The SCI monitors the communication line. When it detects a start bit (0 bit), the SCI synchronizes internally and starts receiving.
- Receive data is stored in RSR in order from LSB to MSB.
- The parity bit and stop bit are received.

After receiving these bits, the SCI carries out the following checks:

- Parity check: The number of 1s in the receive data must match the even or odd parity setting of in the O/\bar{E} bit in SMR.
- Stop bit check: The stop bit value must be 1. If there are two stop bits, only the first is checked.
- Status check: The RDRF flag must be 0, indicating that the receive data can be transferred from RSR into RDR.

If these all checks pass, the RDRF flag is set to 1 and the received data is stored in RDR. If one of the checks fails (receive error*), the SCI operates as shown in table 13.11.

Note: * When a receive error occurs, further receiving is disabled. In receiving, the RDRF flag is not set to 1. Be sure to clear the error flags to 0.

- When the RDRF flag is set to 1, if the RIE bit is set to 1 in SCR, a receive-data-full interrupt (RXI) is requested. If the ORER, PER, or FER flag is set to 1 and the RIE bit in SCR is also set to 1, a receive-error interrupt (ERI) is requested.

Table 13.11 Receive Error Conditions

Receive Error	Abbreviation	Condition	Data Transfer
Overrun error	ORER	Receiving of next data ends while RDRF flag is still set to 1 in SSR	Receive data is not transferred from RSR to RDR
Framing error	FER	Stop bit is 0	Receive data is transferred from RSR to RDR
Parity error	PER	Parity of received data differs from even/odd parity setting in SMR	Receive data is transferred from RSR to RDR

Figure 13.8 shows an example of SCI receive operation in asynchronous mode.

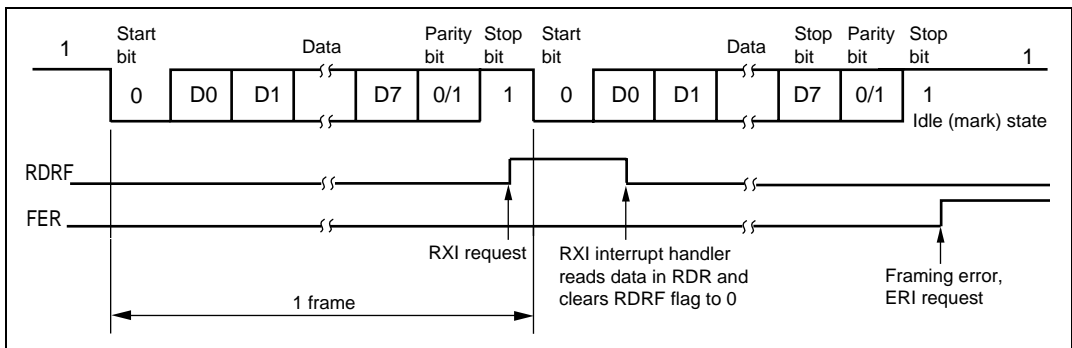

**Figure 13.8 Example of SCI Receive Operation
(8-Bit Data with Parity and One Stop Bit)**

13.3.3 Multiprocessor Communication

The multiprocessor communication function enables several processors to share a single serial communication line. The processors communicate in asynchronous mode using a format with an additional multiprocessor bit (multiprocessor format).

In multiprocessor communication, each receiving processor is addressed by an ID. A serial communication cycle consists of an ID-sending cycle that identifies the receiving processor, and a data-sending cycle. The multiprocessor bit distinguishes ID-sending cycles from data-sending cycles.

The transmitting processor starts by sending the ID of the receiving processor with which it wants to communicate as data with the multiprocessor bit set to 1. Next the transmitting processor sends transmit data with the multiprocessor bit cleared to 0.

Receiving processors skip incoming data until they receive data with the multiprocessor bit set to 1. When they receive data with the multiprocessor bit set to 1, receiving processors compare the data with their IDs. Processors with IDs not matching the received data skip further incoming data until they again receive data with the multiprocessor bit set to 1. Multiple processors can send and receive data in this way.

Figure 13.9 shows an example of communication among different processors using a multiprocessor format.

Communication Formats: Four formats are available. Parity bit settings are ignored when a multiprocessor format is selected. For details see table 13.10.

Clock: See the description of asynchronous mode.

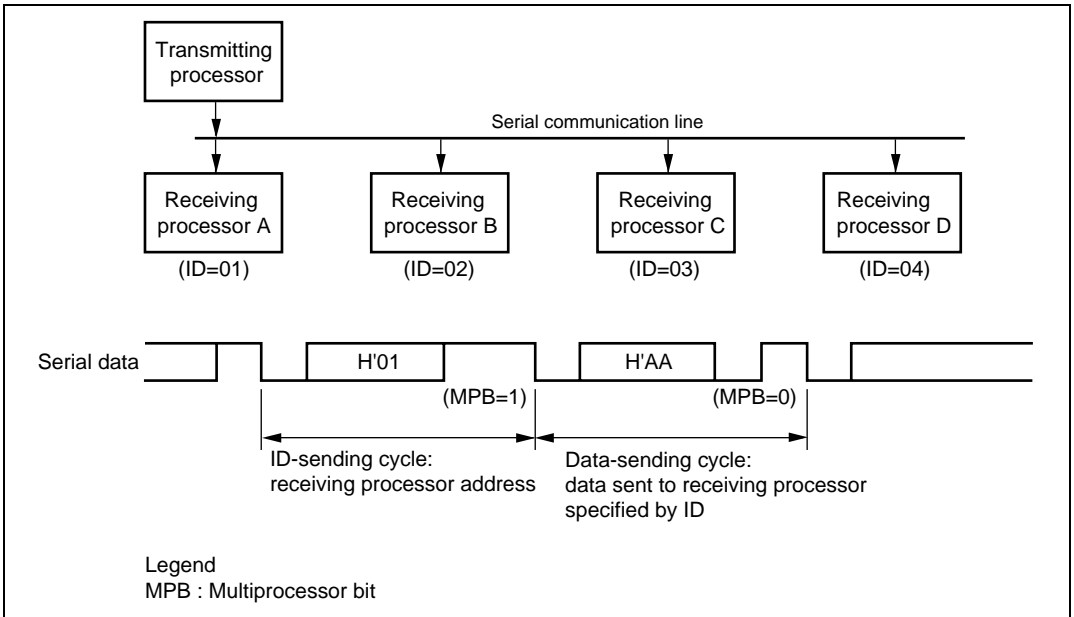

Figure 13.9 Example of Communication among Processors using Multiprocessor Format (Sending Data H'AA to Receiving Processor A)

Transmitting and Receiving Data:

- Transmitting Multiprocessor Serial Data: Figure 13.10 shows a sample flowchart for transmitting multiprocessor serial data and indicates the procedure to follow.

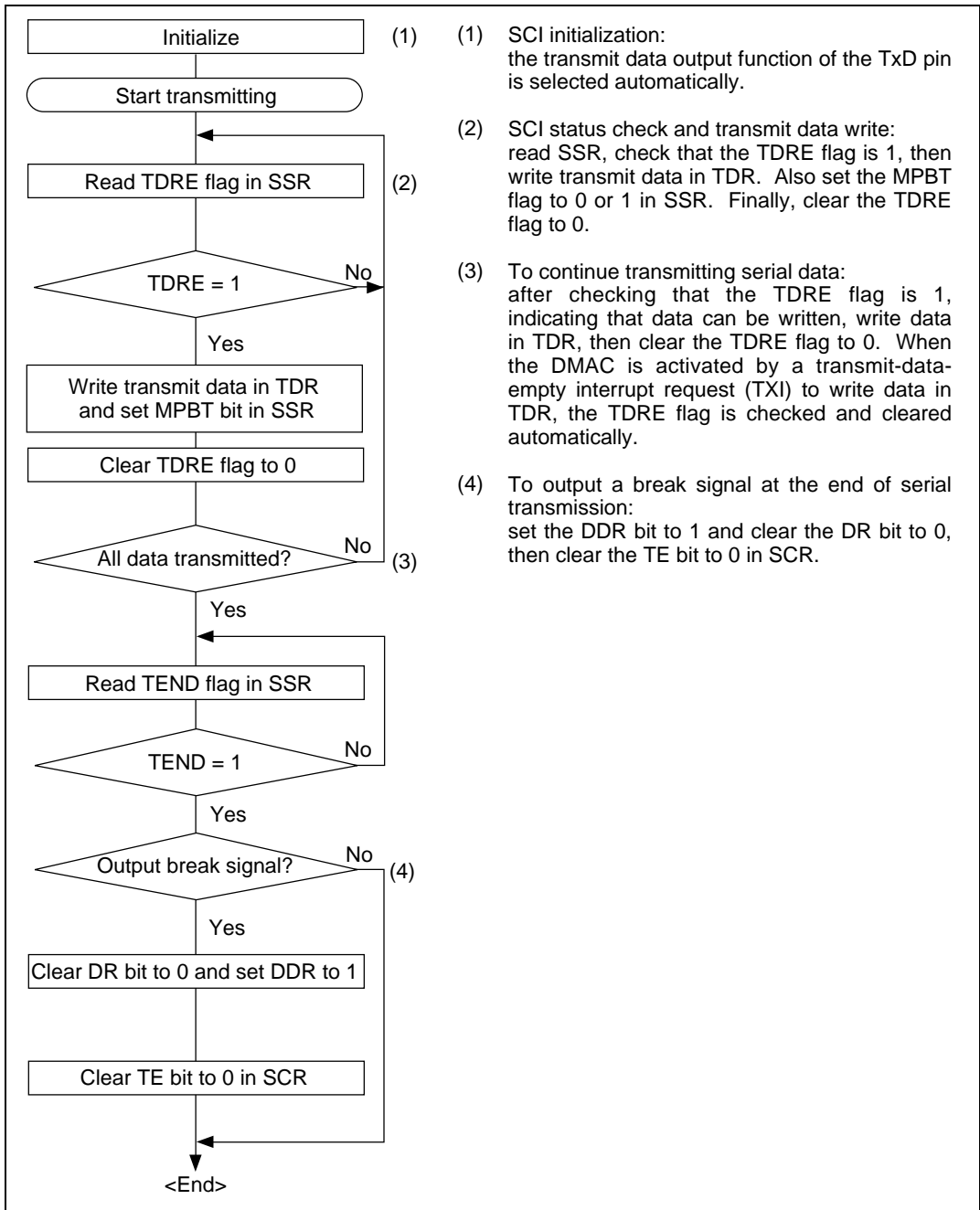

Figure 13.10 Sample Flowchart for Transmitting Multiprocessor Serial Data

In transmitting serial data, the SCI operates as follows:

- The SCI monitors the TDRE flag in SSR. When the TDRE flag is cleared to 0, the SCI recognizes that TDR contains new data, and loads this data from TDR into TSR.
- After loading the data from TDR to TSR, the SCI sets the TDRE flag to 1 and starts transmitting. If the TIE bit is set to 1 in SCR, the SCI requests a transmit-data-empty interrupt (TXI) at this time.

Serial transmit data is transmitted in the following order from the TxD pin:

- Start bit: One 0 bit is output.
- Transmit data: 7 or 8 bits are output, LSB first.
- Multiprocessor bit: One multiprocessor bit (MPBT value) is output.
- Stop bit(s): One or two 1 bits (stop bits) are output.
- Mark state: Output of 1 bits continues until the start bit of the next transmit data.

- The SCI checks the TDRE flag when it outputs the stop bit. If the TDRE flag is 0, the SCI loads new data from TDR into TSR, outputs the stop bit, then begins serial transmission of the next frame. If the TDRE flag is 1, the SCI sets the TEND flag to 1 in SSR, outputs the stop bit, then continues output of 1 bits in the mark state. If the TEIE bit is set to 1 in SCR, a transmit-end interrupt (TEI) is requested at this time

Figure 13.11 shows an example of SCI transmit operation using a multiprocessor format.

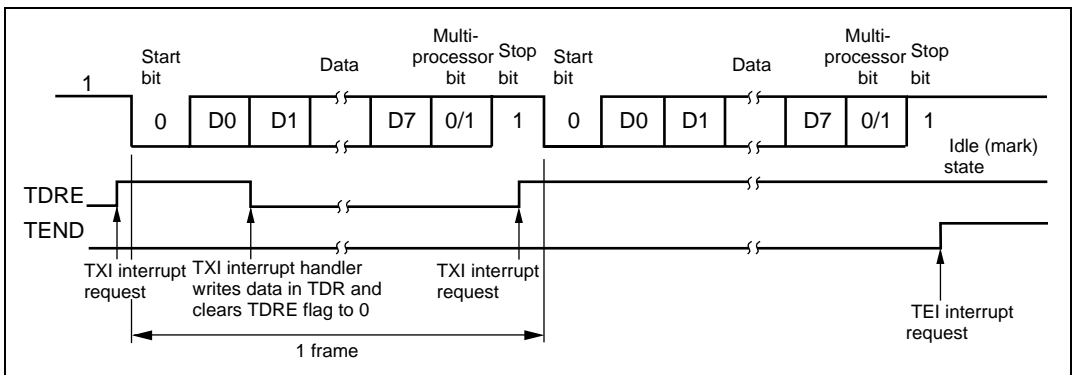

**Figure 13.11 Example of SCI Transmit Operation
(8-Bit Data with Multiprocessor Bit and One Stop Bit)**

- Receiving Multiprocessor Serial Data: Figure 13.12 shows a sample flowchart for receiving multiprocessor serial data and indicates the procedure to follow.

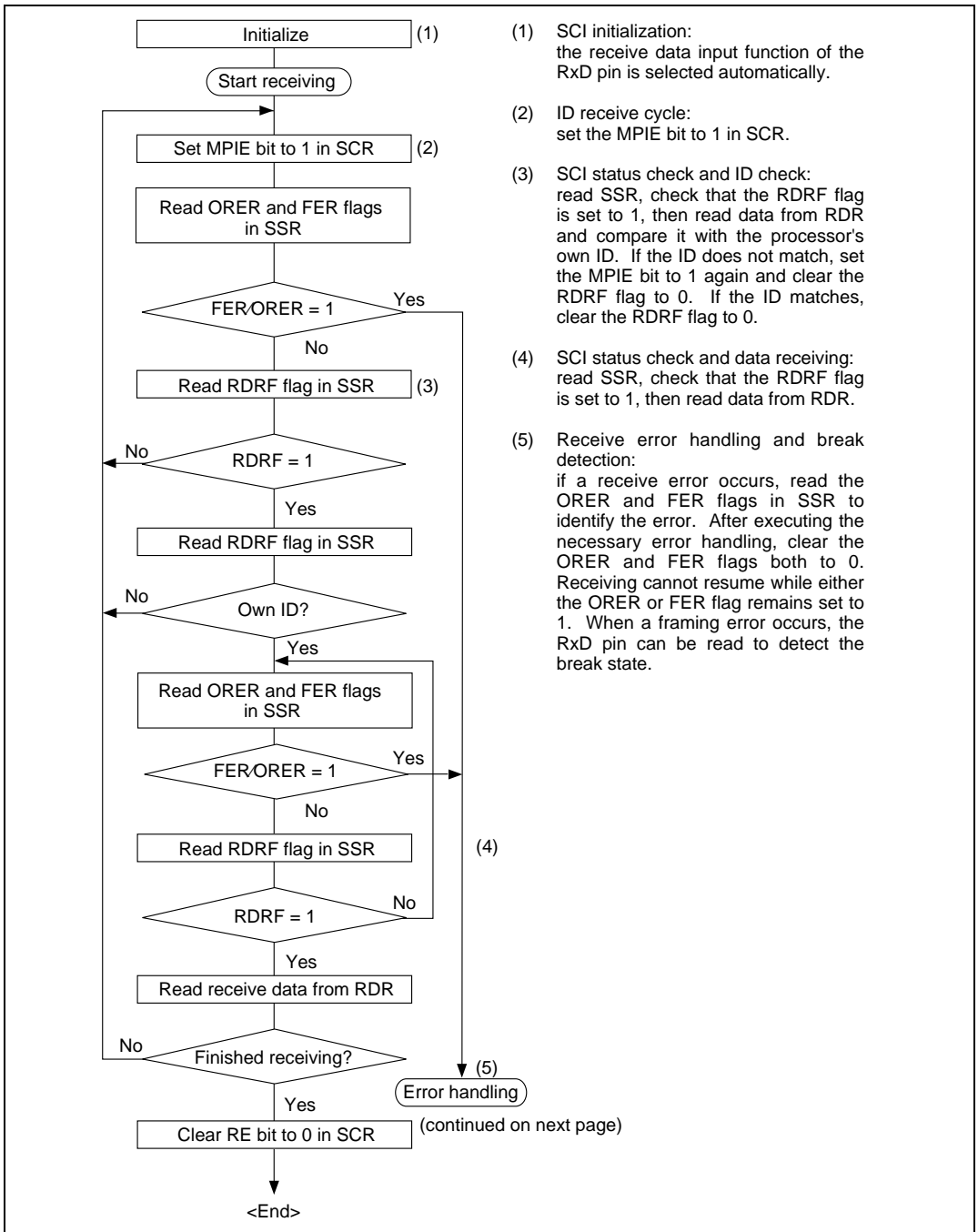

Figure 13.12 Sample Flowchart for Receiving Multiprocessor Serial Data (1)

**Figure 13.12 Sample Flowchart for Receiving Multiprocessor Serial Data (2)**

Figure 13.13 shows an example of SCI receive operation using a multiprocessor format.



**Figure 13.13 Example of SCI Receive Operation
(8-Bit Data with Multiprocessor Bit and One Stop Bit)**

13.3.4 Synchronous Operation

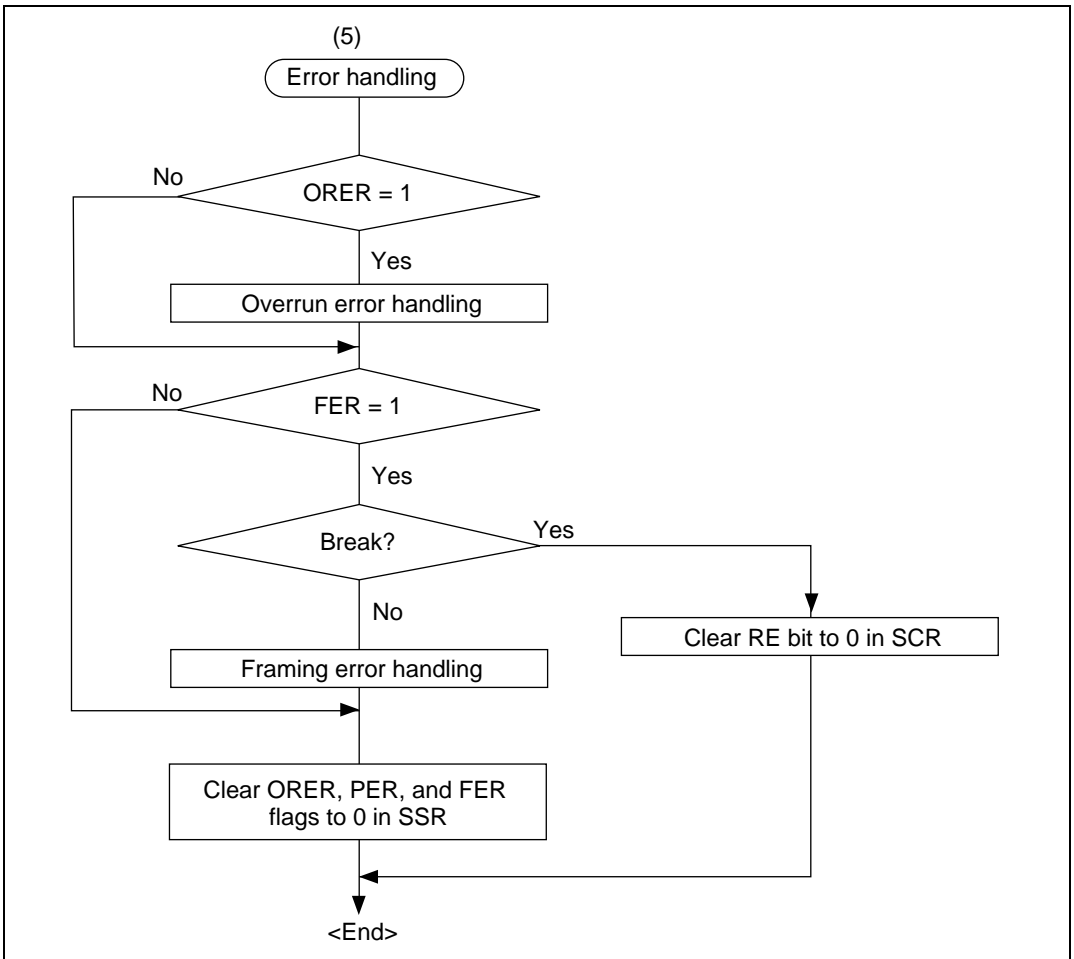
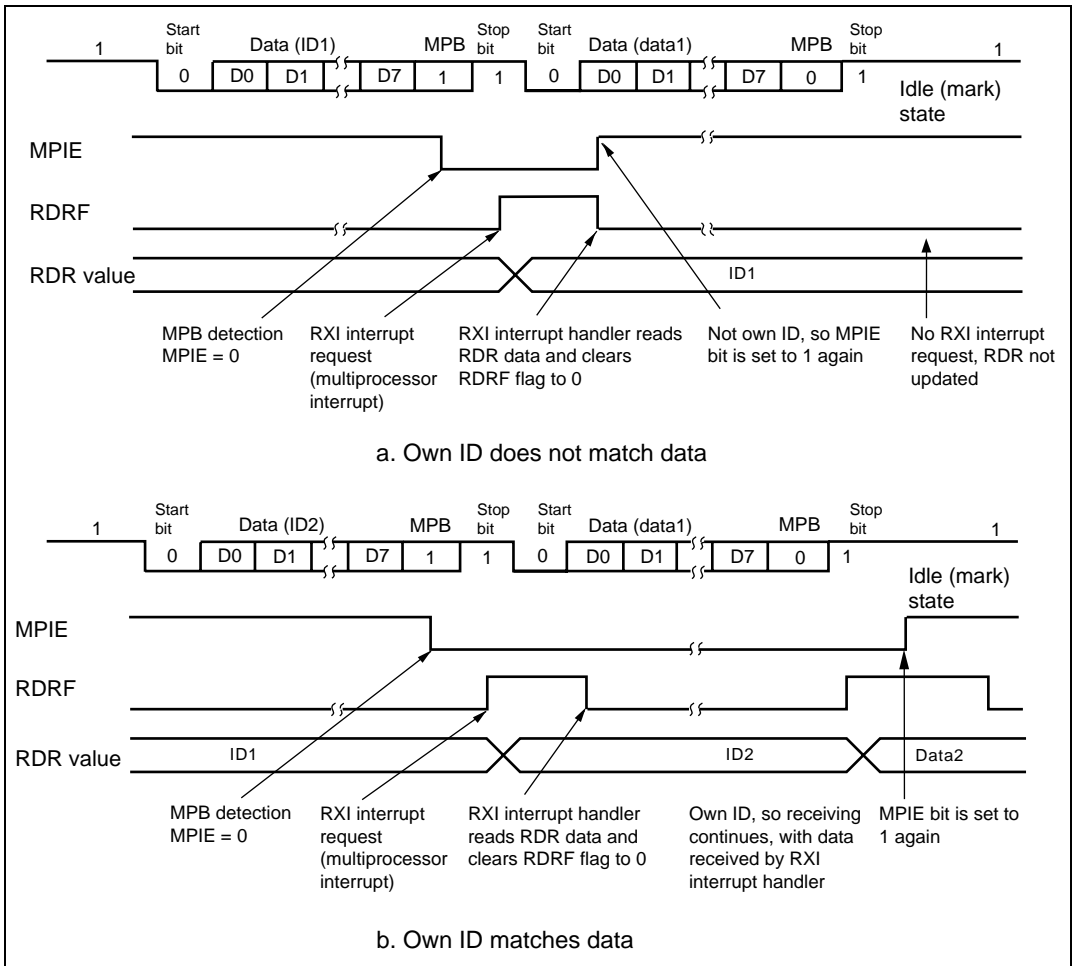
In synchronous mode, the SCI transmits and receives data in synchronization with clock pulses. This mode is suitable for high-speed serial communication.

The SCI transmitter and receiver share the same clock but are otherwise independent, so full-duplex communication is possible. The transmitter and the receiver are also double-buffered, so continuous transmitting or receiving is possible by reading or writing data while transmitting or receiving is in progress.

Figure 13.14 shows the general format in synchronous serial communication.

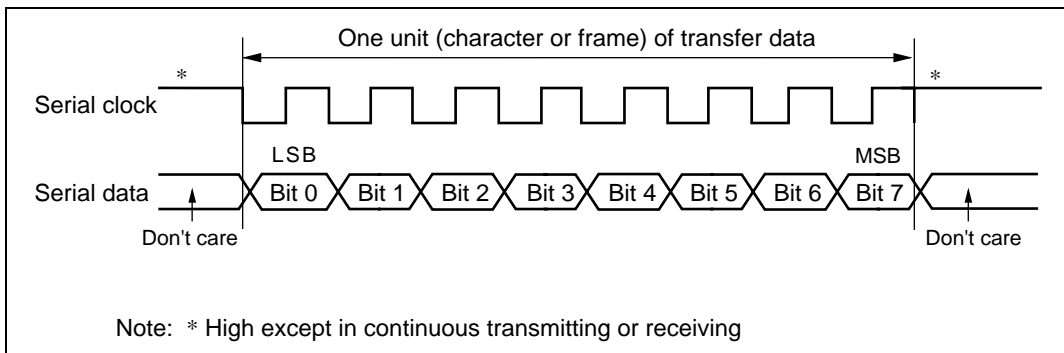

Figure 13.14 Data Format in Synchronous Communication

In synchronous serial communication, each data bit is placed on the communication line from one falling edge of the serial clock to the next. Data is guaranteed valid at the rise of the serial clock. In each character, the serial data bits are transferred in order from LSB (first) to MSB (last). After output of the MSB, the communication line remains in the state of the MSB. In synchronous mode the SCI receives data by synchronizing with the rise of the serial clock.

Communication Format: The data length is fixed at 8 bits. No parity bit or multiprocessor bit can be added.

Clock: An internal clock generated by the on-chip baud rate generator or an external clock input from the SCK pin can be selected by means of the C/\bar{A} bit in SMR and the CKE1 and CKE0 bits in SCR. See table 13.6 for details of SCI clock source selection.

When the SCI operates on an internal clock, it outputs the clock source at the SCK pin. Eight clock pulses are output per transmitted or received character. When the SCI is not transmitting or receiving, the clock signal remains in the high state. If receiving in single-character units is required, an external clock should be selected.

Transmitting and Receiving Data:

- **SCI Initialization (Synchronous Mode):** Before transmitting or receiving data, clear the TE and RE bits to 0 in SCR, then initialize the SCI as follows.

When changing the communication mode or format, always clear the TE and RE bits to 0 before following the procedure given below. Clearing TE to 0 sets the TDRE flag to 1 and initializes TSR. Note that clearing RE to 0, however, does not initialize the RDRF, PER, and ORE flags, or RDR, which retain their previous contents.

Figure 13.15 shows a sample flowchart for initializing the SCI.

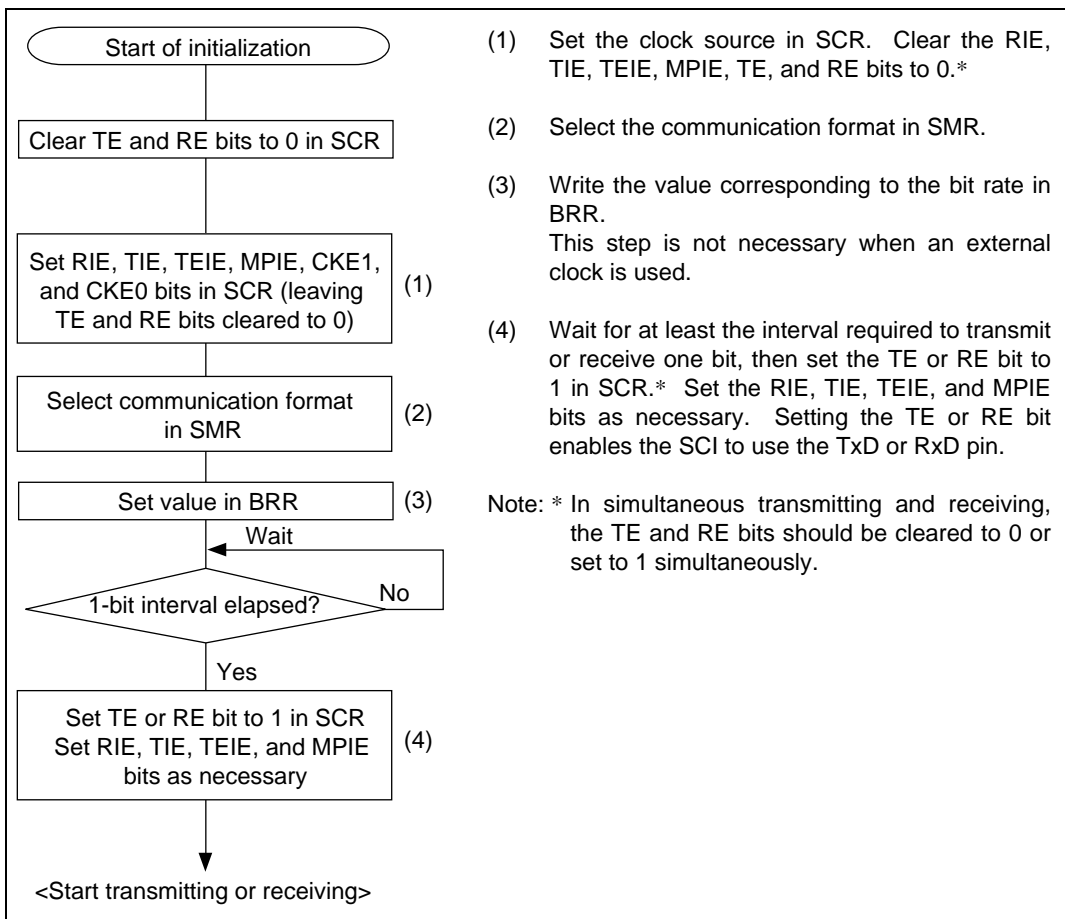

Figure 13.15 Sample Flowchart for SCI Initialization

- Transmitting Serial Data (Synchronous Mode): Figure 13.16 shows a sample flowchart for transmitting serial data and indicates the procedure to follow.

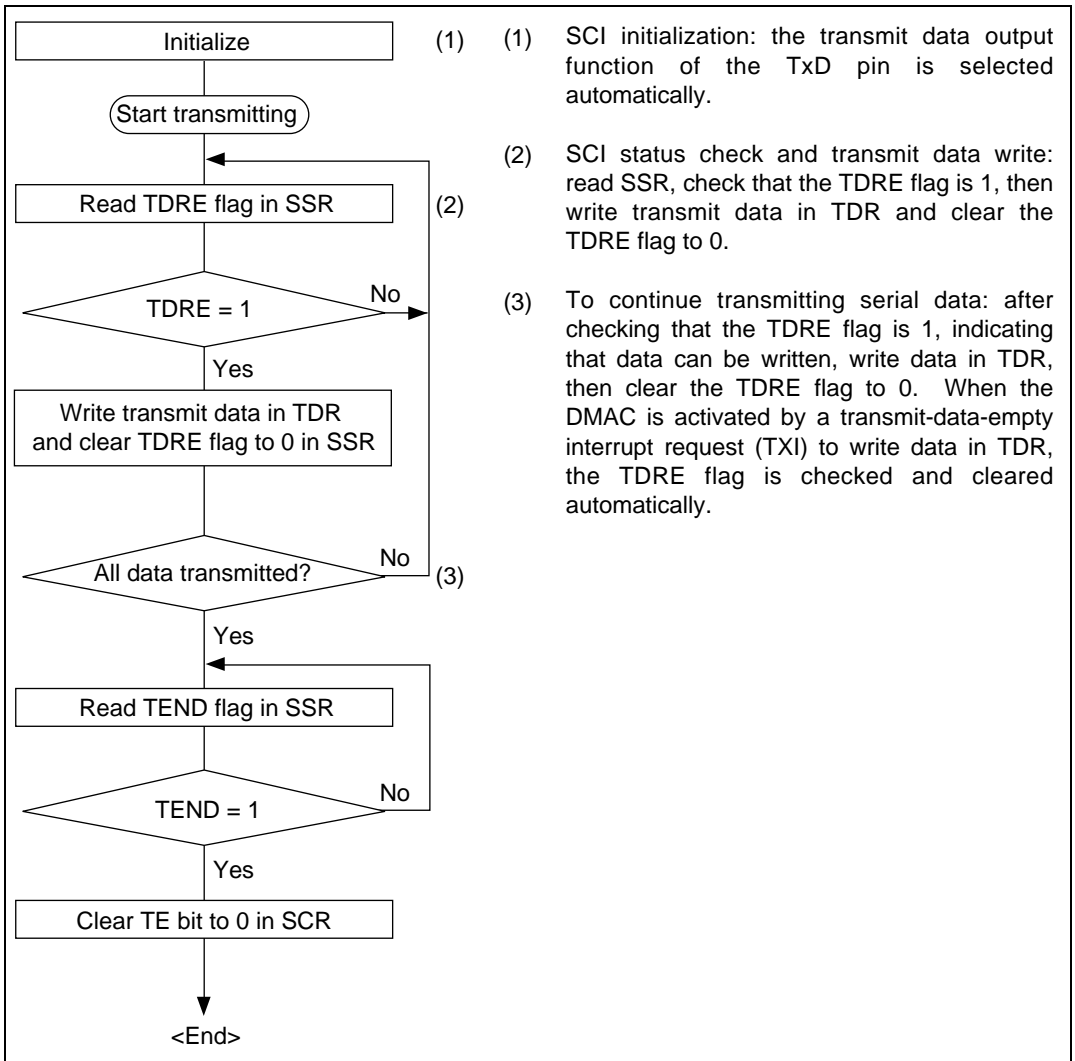

Figure 13.16 Sample Flowchart for Serial Transmitting

In transmitting serial data, the SCI operates as follows.

- The SCI monitors the TDRE flag in SSR. When the TDRE flag is cleared to 0, the SCI recognizes that TDR contains new data, and loads this data from TDR into TSR.
- After loading the data from TDR to TSR, the SCI sets the TDRE flag to 1 and starts transmitting. If the TIE bit is set to 1 in SCR, the SCI requests a transmit-data-empty interrupt (TXI) at this time.

If clock output is selected, the SCI outputs eight serial clock pulses. If an external clock source is selected, the SCI outputs data in synchronization with the input clock. Data is output from the TxD pin in order from LSB (bit 0) to MSB (bit 7).

- The SCI checks the TDRE flag when it outputs the MSB (bit 7). If the TDRE flag is 0, the SCI loads data from TDR into TSR and begins serial transmission of the next frame. If the TDRE flag is 1, the SCI sets the TEND flag to 1 in SSR, and after transmitting the MSB (bit 7), holds the TxD pin in the MSB state. If the TEIE bit is set to 1 in SCR, a transmit-end interrupt (TEI) is requested at this time.
- After the end of serial transmission, the SCK pin is held in a constant state.

Figure 13.17 shows an example of SCI transmit operation.

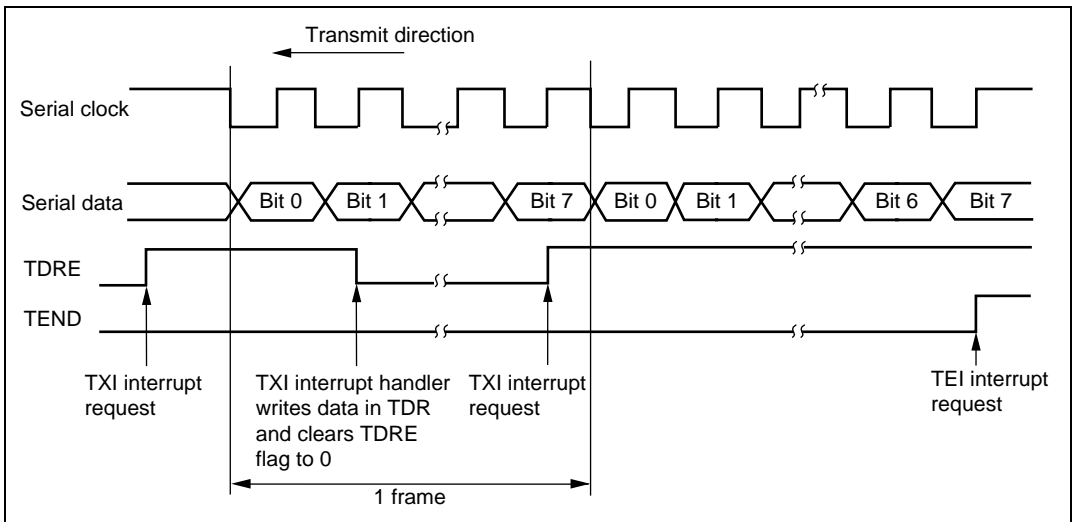

Figure 13.17 Example of SCI Transmit Operation

- Receiving Serial Data (Synchronous Mode): Figure 13.18 shows a sample flowchart for receiving serial data and indicates the procedure to follow. When switching from asynchronous to synchronous mode, make sure that the ORER, PER, and FER flags are cleared to 0. If the FER or PER flag is set to 1 the RDRF flag will not be set and both transmitting and receiving will be disabled.

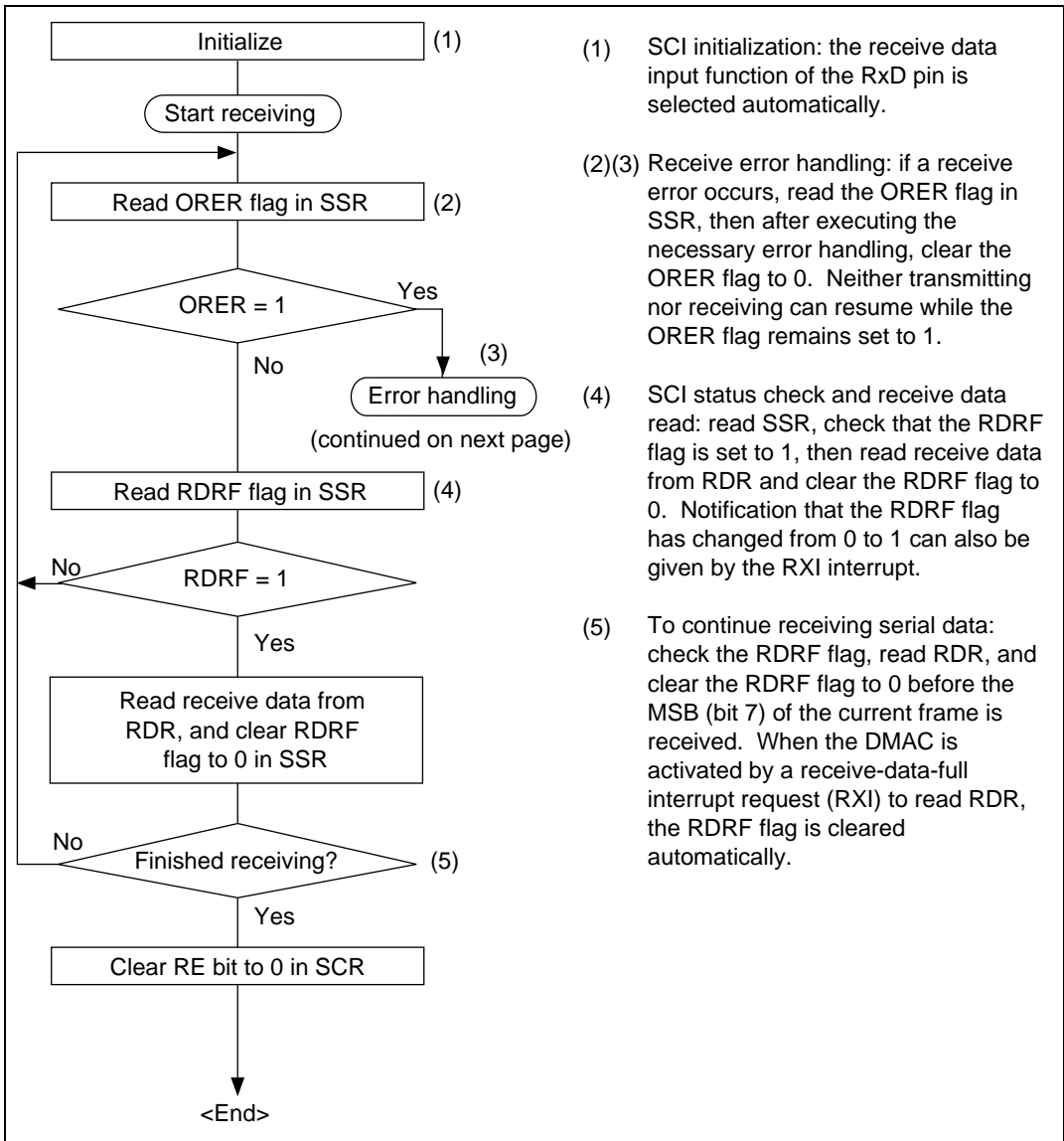

Figure 13.18 Sample Flowchart for Serial Receiving (1)

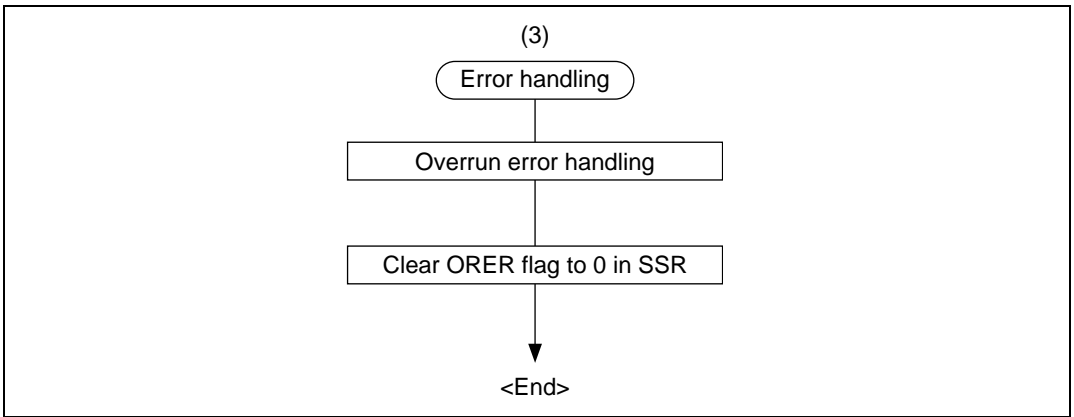

Figure 13.18 Sample Flowchart for Serial Receiving (2)

In receiving, the SCI operates as follows:

- The SCI synchronizes with serial clock input or output and synchronizes internally.
- Receive data is stored in RSR in order from LSB to MSB.
After receiving the data, the SCI checks that the RDRF flag is 0, so that receive data can be transferred from RSR to RDR. If this check passes, the RDRF flag is set to 1 and the received data is stored in RDR. If the checks fails (receive error), the SCI operates as shown in table 13.11.
When a receive error has been identified in the error check, subsequent transmit and receive operations are disabled.
- When the RDRF flag is set to 1, if the RIE bit is set to 1 in SCR, a receive-data-full interrupt (RXI) is requested. If the ORER flag is set to 1 and the RIE bit in SCR is also set to 1, a receive-error interrupt (ERI) is requested.

Figure 13.19 shows an example of SCI receive operation.

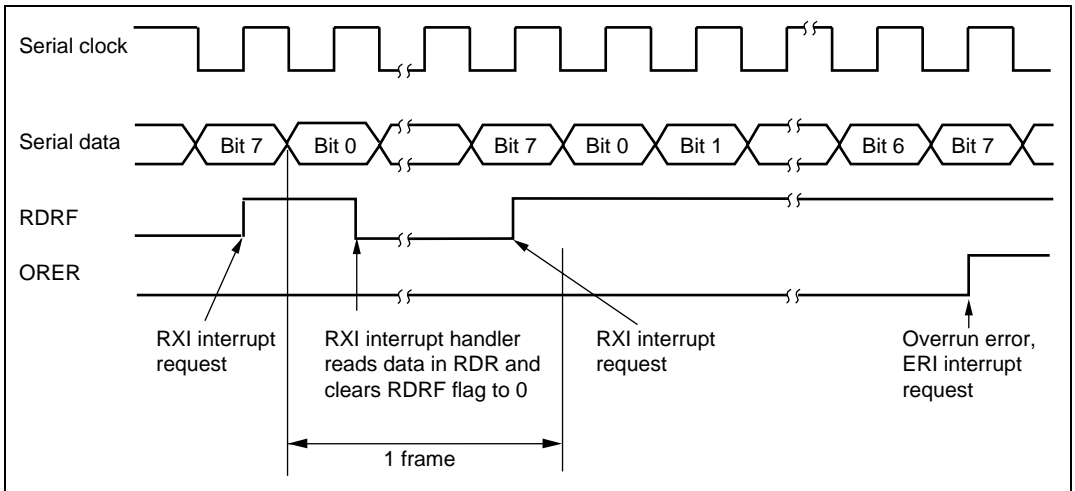

Figure 13.19 Example of SCI Receive Operation

- **Transmitting and Receiving Data Simultaneously (Synchronous Mode):** Figure 13.20 shows a sample flowchart for transmitting and receiving serial data simultaneously and indicates the procedure to follow.

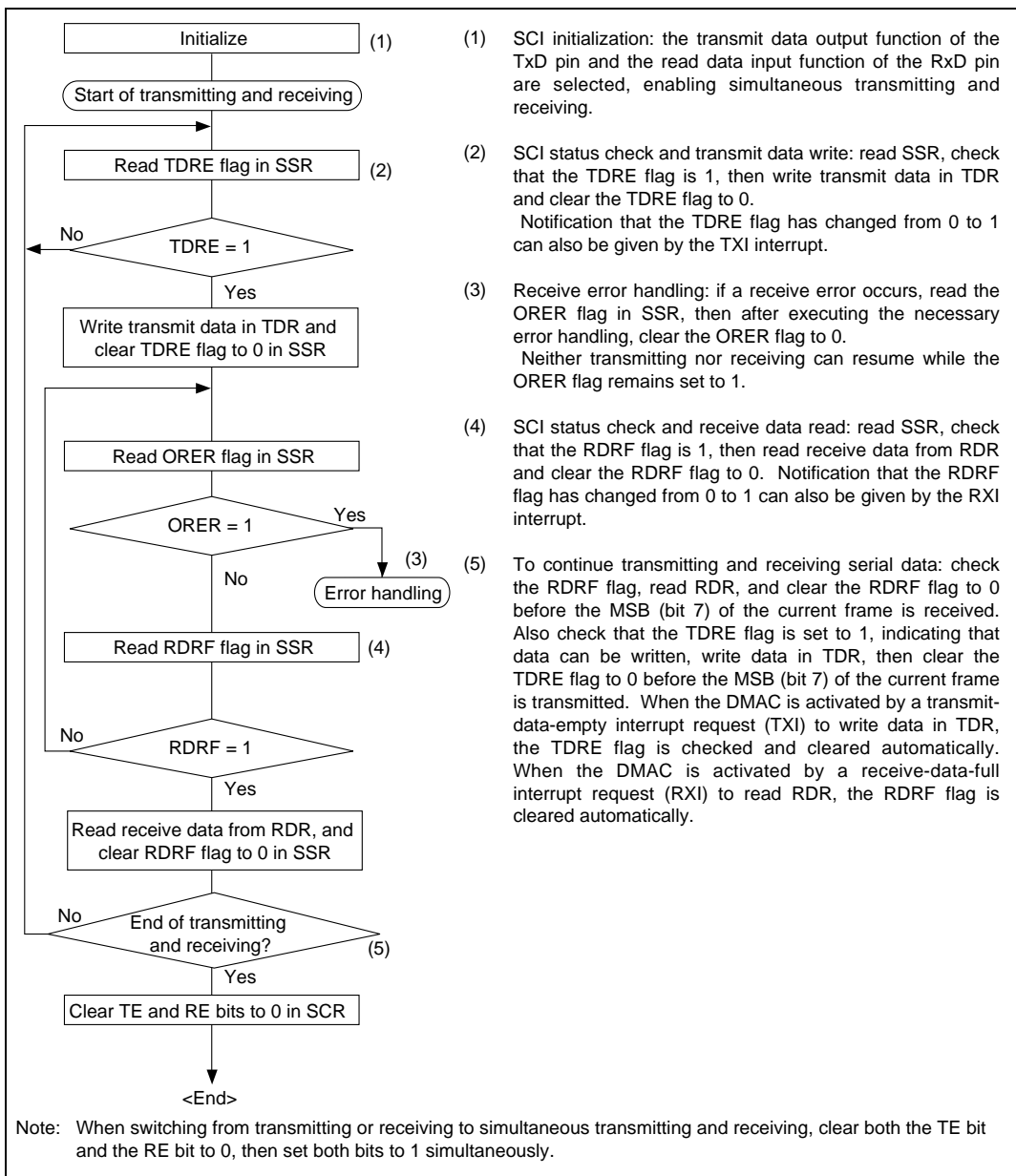

Figure 13.20 Sample Flowchart for Simultaneous Serial Transmitting and Receiving

13.4 SCI Interrupts

The SCI has four interrupt request sources: the transmit-end interrupt (TEI), receive-error interrupt (ERI), receive-data-full interrupt (RXI), and transmit-data-empty interrupt (TXI). Table 13.12 lists the interrupt sources and indicates their priority. These interrupts can be enabled or disabled by the TIE, RIE, and TEIE bits in SCR. Each interrupt request is sent separately to the interrupt controller.

A TXI interrupt is requested when the TDRE flag is set to 1 in SSR. A TEI interrupt is requested when the TEND flag is set to 1 in SSR. A TXI interrupt request can activate the DMAC to transfer data. Data transfer by the DMAC automatically clears the TDRE flag to 0. A TEI interrupt request cannot activate the DMAC.

An RXI interrupt is requested when the RDRF flag is set to 1 in SSR. An ERI interrupt is requested when the ORER, PER, or FER flag is set to 1 in SSR. An RXI interrupt can activate the DMAC to transfer data. Data transfer by the DMAC automatically clears the RDRF flag to 0. An ERI interrupt request cannot activate the DMAC.

The DMAC can be activated by interrupts from SCI channel 0.

Table 13.12 SCI Interrupt Sources

Interrupt Source	Description	Priority
ERI	Receive error (ORER, FER, or PER)	High
RXI	Receive data register full (RDRF)	↑
TXI	Transmit data register empty (TDRE)	↓
TEI	Transmit end (TEND)	Low

13.5 Usage Notes

13.5.1 Notes on Use of SCI

Note the following points when using the SCI.

TDR Write and TDRE Flag: The TDRE flag in SSR is a status flag indicating the loading of transmit data from TDR to TSR. The SCI sets the TDRE flag to 1 when it transfers data from TDR to TSR.

Data can be written into TDR regardless of the state of the TDRE flag. If new data is written in TDR when the TDRE flag is 0, the old data stored in TDR will be lost because this data has not yet been transferred to TSR. Before writing transmit data in TDR, be sure to check that the TDRE flag is set to 1.

Simultaneous Multiple Receive Errors: Table 13.13 shows the state of the SSR status flags when multiple receive errors occur simultaneously. When an overrun error occurs the RSR contents are not transferred to RDR, so receive data is lost.

Table 13.13 SSR Status Flags and Transfer of Receive Data

SSR Status Flags				Receive Data Transfer	
RDRF	ORER	FER	PER	RSR → RDR	Receive Errors
1	1	0	0	×	Overrun error
0	0	1	0	○	Framing error
0	0	0	1	○	Parity error
1	1	1	0	×	Overrun error + framing error
1	1	0	1	×	Overrun error + parity error
0	0	1	1	○	Framing error + parity error
1	1	1	1	×	Overrun error + framing error + parity error

Notes: ○: Receive data is transferred from RSR to RDR.

×: Receive data is not transferred from RSR to RDR.

Break Detection and Processing: Break signals can be detected by reading the RxD pin directly when a framing error (FER) is detected. In the break state the input from the RxD pin consists of all 0s, so the FER flag is set and the parity error flag (PER) may also be set. In the break state the SCI receiver continues to operate, so if the FER flag is cleared to 0 it will be set to 1 again.

Sending a Break Signal: The input/output condition and level of the TxD pin are determined by DR and DDR bits. This feature can be used to send a break signal.

After the serial transmitter is initialized, the DR value substitutes for the mark state until the TE bit is set to 1 (the TxD pin function is not selected until the TE bit is set to 1). The DDR and DR bits should therefore be set to 1 beforehand.

To send a break signal during serial transmission, clear the DR bit to 0, then clear the TE bit to 0. When the TE bit is cleared to 0 the transmitter is initialized, regardless of its current state, so the TxD pin becomes an input/output outputting the value 0.

Receive Error Flags and Transmitter Operation (Synchronous Mode Only): When a receive error flag (ORER, PER, or FER) is set to 1 the SCI will not start transmitting, even if the TDRE flag is cleared to 0. Be sure to clear the receive error flags to 0 when starting to transmit. Note that clearing the RE bit to 0 does not clear the receive error flags to 0.

Receive Data Sampling Timing in Asynchronous Mode and Receive Margin: In asynchronous mode the SCI operates on a base clock with 16 times the bit rate frequency. In receiving, the SCI synchronizes internally with the fall of the start bit, which it samples on the base clock. Receive data is latched at the rising edge of the eighth base clock pulse. See figure 13.21.

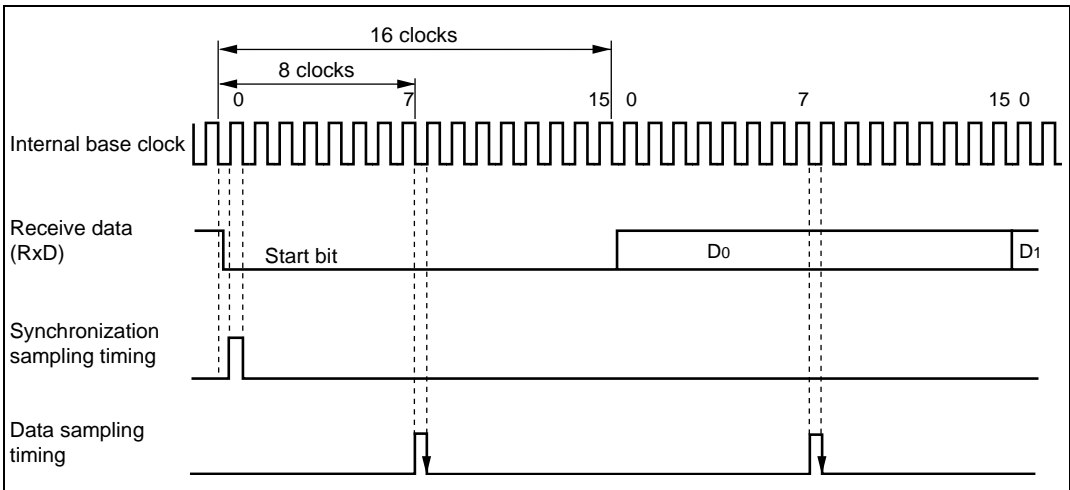

Figure 13.21 Receive Data Sampling Timing in Asynchronous Mode

The receive margin in asynchronous mode can therefore be expressed as shown in equation (1).

$$M = \left| \left(0.5 - \frac{1}{2N} \right) - (L - 0.5) F - \frac{|D - 0.5|}{N} (1 + F) \right| \times 100\% \quad \dots \dots \dots (1)$$

- M: Receive margin (%)
- N: Ratio of clock frequency to bit rate (N = 16)
- D: Clock duty cycle (L = 0 to 1.0)
- L: Frame length (L = 9 to 12)
- F: Absolute deviation of clock frequency

From equation (1), if F = 0 and D = 0.5, the receive margin is 46.875%, as given by equation (2).

$$D = 0.5, F = 0$$

$$M = \left(0.5 - \frac{1}{2 \times 16} \right) \times 100\% = 46.875\% \quad \dots \dots \dots (2)$$

This is a theoretical value. A reasonable margin to allow in system designs is 20% to 30%.

Restrictions on Use of DMAC:

- When an external clock source is used for the serial clock, after the DMAC updates TDR, allow an inversion of at least five system clock (ϕ) cycles before input of the serial clock to start transmitting. If the serial clock is input within four states of the TDR update, a malfunction may occur. (See figure 13.22)
- To have the DMAC read RDR, be sure to select the corresponding SCI receive-data-full interrupt (RXI) as the activation source with bits DTS2 to DTS0 in DTCR.

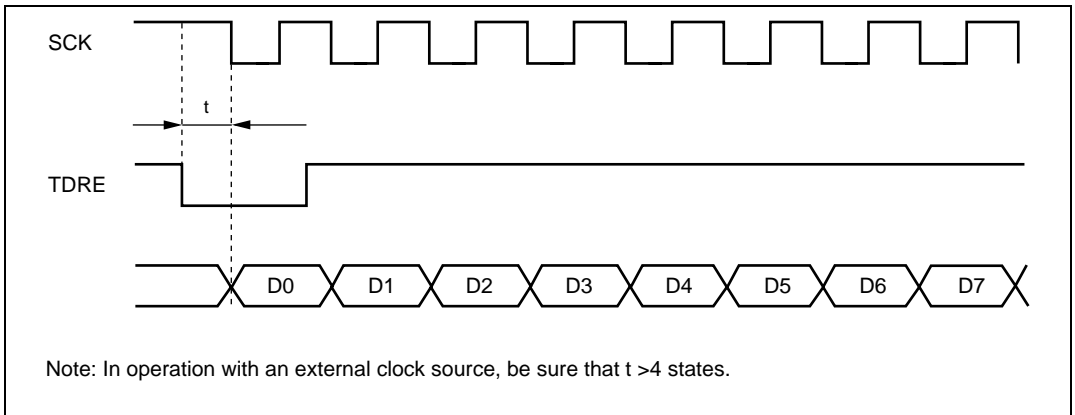
**Figure 13.22 Example of Synchronous Transmission Using DMAC**

Switching from SCK Pin Function to Port Pin Function:

- Problem in Operation: When switching the SCK pin function to the output port function (high-level output) by making the following settings while $DDR = 1$, $DR = 1$, $C/\bar{A} = 1$, $CKE1 = 0$, $CKE0 = 0$, and $TE = 1$ (synchronous mode), low-level output occurs for one half-cycle.

1. End of serial data transmission
2. $TE = 0$
3. C/\bar{A} bit = 0 ... switchover to port output
4. Occurrence of low-level output (see figure 13.23)

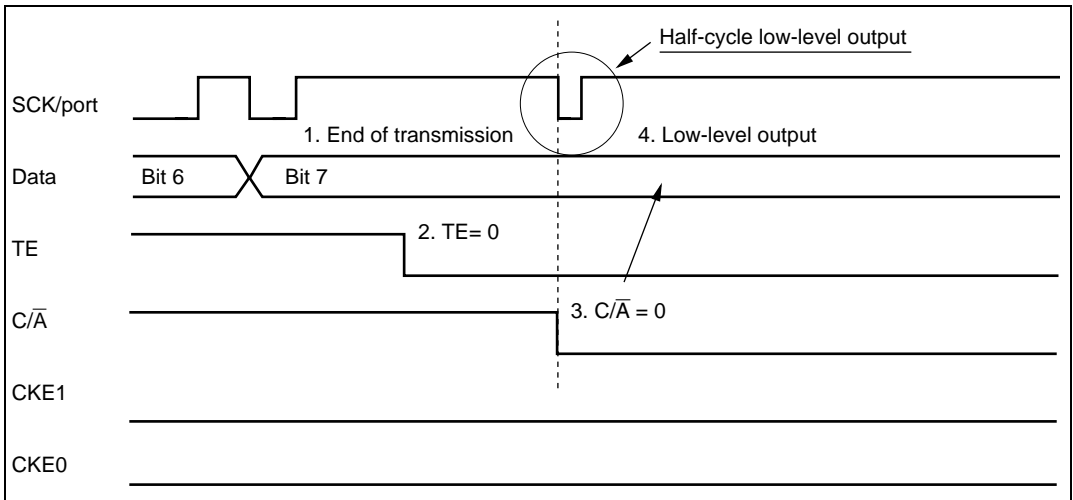
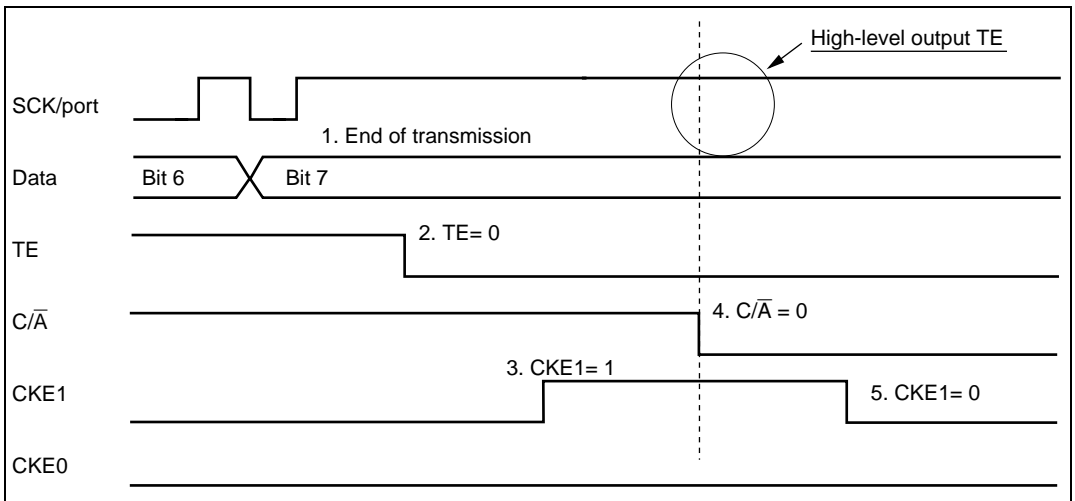

Figure 13.23 Operation when Switching from SCK Pin Function to Port Pin Function

- **Sample Procedure for Avoiding Low-Level Output:** As this sample procedure temporarily places the SCK pin in the input state, the SCK/port pin should be pulled up beforehand with an external circuit.

With $DDR = 1$, $DR = 1$, $C/\bar{A} = 1$, $CKE1 = 0$, $CKE0 = 0$, and $TE = 1$, make the following settings in the order shown.

1. End of serial data transmission
2. TE bit = 0
3. $CKE1$ bit = 1
4. C/\bar{A} bit = 0 ... switchover to port output
5. $CKE1$ bit = 0



**Figure 13.24 Operation when Switching from SCK Pin Function to Port Pin Function
(Example of Preventing Low-Level Output)**

Section 14 Smart Card Interface

14.1 Overview

An IC card (smart card) interface conforming to the ISO/IEC 7816-3 (Identification Card) standard is supported as an extension of the serial communication interface (SCI) functions.

Switchover between the normal serial communication interface and the smart card interface is controlled by a register setting.

14.1.1 Features

Features of the smart card interface supported by the H8/3068F are listed below.

- Asynchronous communication
 - Data length: 8 bits
 - Parity bit generation and checking
 - Transmission of error signal (parity error) in receive mode
 - Error signal detection and automatic data retransmission in transmit mode
 - Direct convention and inverse convention both supported
- Built-in baud rate generator allows any bit rate to be selected
- Three interrupt sources
 - There are three interrupt sources—transmit-data-empty, receive-data-full, and transmit/receive error—that can issue requests independently.
 - The transmit-data-empty interrupt and receive-data-full interrupt can activate the DMA controller (DMAC) to execute data transfer.

14.1.2 Block Diagram

Figure 14.1 shows a block diagram of the smart card interface.

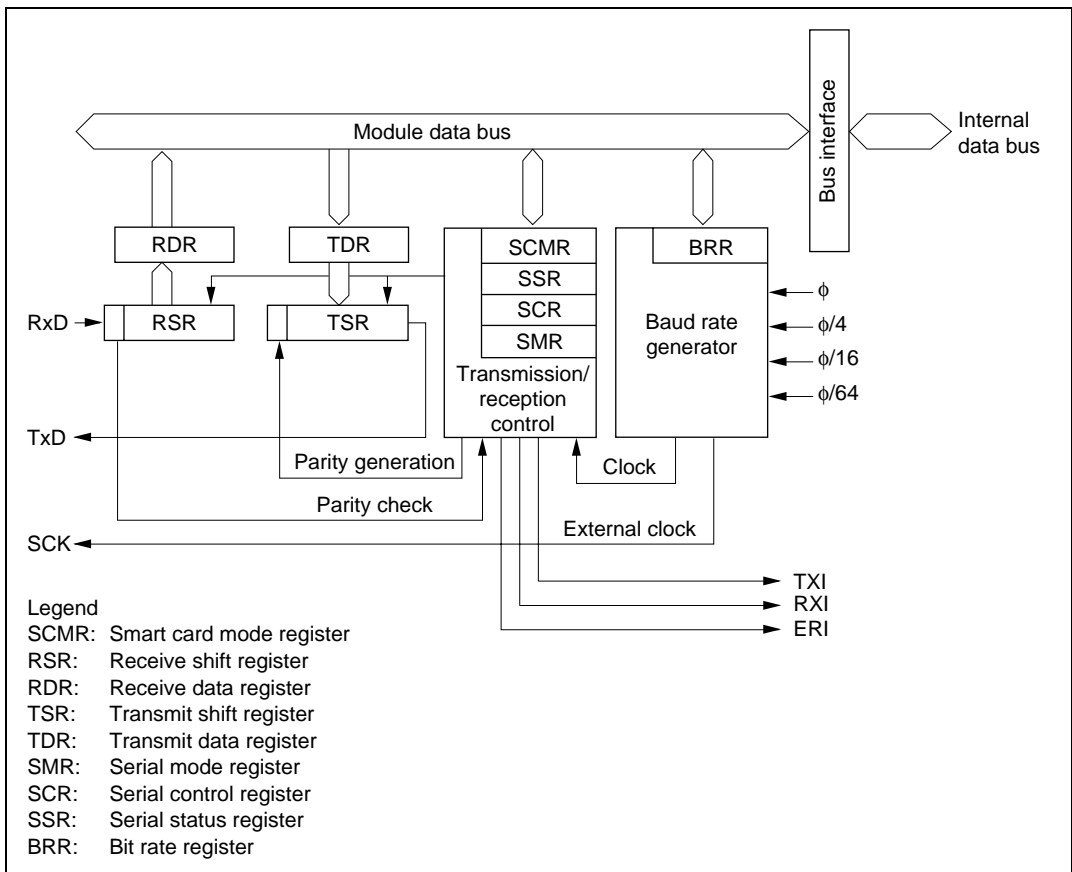

Figure 14.1 Block Diagram of Smart Card Interface

14.1.3 Pin Configuration

Table 14.1 shows the smart card interface pins.

Table 14.1 Smart Card Interface Pins

Pin Name	Abbreviation	I/O	Function
Serial clock pin	SCK	I/O	Clock input/output
Receive data pin	RxD	Input	Receive data input
Transmit data pin	TxD	Output	Transmit data output

14.1.4 Register Configuration

The smart card interface has the internal registers listed in table 14.2. The BRR, TDR, and RDR registers have their normal serial communication interface functions, as described in section 13, Serial Communication Interface.

Table 14.2 Smart Card Interface Registers

Channel	Address* ¹	Name	Abbreviation	R/W	Initial Value
0	H'FFFB0	Serial mode register	SMR	R/W	H'00
	H'FFFB1	Bit rate register	BRR	R/W	H'FF
	H'FFFB2	Serial control register	SCR	R/W	H'00
	H'FFFB3	Transmit data register	TDR	R/W	H'FF
	H'FFFB4	Serial status register	SSR	R/(W)* ²	H'84
	H'FFFB5	Receive data register	RDR	R	H'00
	H'FFFB6	Smart card mode register	SCMR	R/W	H'F2
1	H'FFFB8	Serial mode register	SMR	R/W	H'00
	H'FFFB9	Bit rate register	BRR	R/W	H'FF
	H'FFFB A	Serial control register	SCR	R/W	H'00
	H'FFFB B	Transmit data register	TDR	R/W	H'FF
	H'FFFB C	Serial status register	SSR	R/(W)* ²	H'84
	H'FFFB D	Receive data register	RDR	R	H'00
	H'FFFB E	Smart card mode register	SCMR	R/W	H'F2
2	H'FFFC0	Serial mode register	SMR	R/W	H'00
	H'FFFC1	Bit rate register	BRR	R/W	H'FF
	H'FFFC2	Serial control register	SCR	R/W	H'00
	H'FFFC3	Transmit data register	TDR	R/W	H'FF
	H'FFFC4	Serial status register	SSR	R/(W)* ²	H'84
	H'FFFC5	Receive data register	RDR	R	H'00
	H'FFFC6	Smart card mode register	SCMR	R/W	H'F2

- Notes: 1. Lower 20 bits of the address in advanced mode.
 2. Only 0 can be written in bits 7 to 3, to clear the flags.

14.2 Register Descriptions

This section describes the new or modified registers and bit functions in the smart card interface.

14.2.1 Smart Card Mode Register (SCMR)

SCMR is an 8-bit readable/writable register that selects smart card interface functions.

Bit	7	6	5	4	3	2	1	0
	—	—	—	—	SDIR	SINV	—	SMIF
Initial value	1	1	1	1	0	0	1	0
Read/Write	—	—	—	—	R/W	R/W	—	R/W

Reserved bits (Bits 7, 6, 5, 4)
Reserved bit (Bit 1)
Smart card interface mode select
 Enables or disables the smart card interface function
Smart card data invert
 Inverts data logic levels
Smart card data transfer direction
 Selects the serial/parallel conversion format

SCMR is initialized to HF2 by a reset and in standby mode.

Bits 7 to 4—Reserved: Read-only bits, always read as 1.

Bit 3—Smart Card Data Transfer Direction (SDIR): Selects the serial/parallel conversion format.*¹

Bit 3

SDIR	Description
0	TDR contents are transmitted LSB-first Receive data is stored LSB-first in RDR (Initial value)
1	TDR contents are transmitted MSB-first Receive data is stored MSB-first in RDR

Bit 2—Smart Card Data Invert (SINV): Specifies inversion of the data logic level. This function is used in combination with the SDIR bit to communicate with inverse-convention cards.*² The SINV bit does not affect the logic level of the parity bit. For parity settings, see section 14.3.4, Register Settings.

Bit 2

SINV	Description	
0	Unmodified TDR contents are transmitted Receive data is stored unmodified in RDR	(Initial value)
1	Inverted TDR contents are transmitted Receive data is inverted before storage in RDR	

Bit 1—Reserved: Read-only bit, always read as 1.

Bit 0—Smart Card Interface Mode Select (SMIF): Enables the smart card interface function.

Bit 0

SMIF	Description	
0	Smart card interface function is disabled	(Initial value)
1	Smart card interface function is enabled	

- Notes:
1. The function for switching between LSB-first and MSB-first mode can also be used with the normal serial communication interface. Note that when the communication format data length is set to 7 bits and MSB-first mode is selected for the serial data to be transferred, bit 0 of TDR is not transmitted, and only bits 7 to 1 of the received data are valid.
 2. The data logic level inversion function can also be used with the normal serial communication interface. Note that, when inverting the serial data to be transferred, parity transmission and parity checking is based on the number of high-level periods at the serial data I/O pin, and not on the register value.

14.2.2 Serial Status Register (SSR)

The function of SSR bit 4 is modified in smart card interface mode. This change also causes a modification to the setting conditions for bit 2 (TEND).

Bit	7	6	5	4	3	2	1	0
	TDRE	RDRF	ORER	ERS	PER	TEND	MPB	MPBT
Initial value	1	0	0	0	0	1	0	0
Read/Write	R/(W)*	R/(W)*	R/(W)*	R/(W)*	R/(W)*	R	R	R/W

Transmit end
 Status flag indicating end of transmission

Error signal status (ERS)
 Status flag indicating that an error signal has been received

Note: * Only 0 can be written, to clear the flag.

Bits 7 to 5: These bits operate as in normal serial communication. For details see section 13.2.7, Serial Status Register (SSR).

Bit 4—Error Signal Status (ERS): In smart card interface mode, this flag indicates the status of the error signal sent from the receiving device to the transmitting device. The smart card interface does not detection framing errors.

Bit 4

ERS	Description
0	Indicates normal transmission, with no error signal returned (Initial value) [Clearing conditions] The chip is reset, or enters standby mode or module stop mode Software reads ERS while it is set to 1, then writes 0.
1	Indicates that the receiving device sent an error signal reporting a parity error [Setting condition] A low error signal was sampled.

Note: Clearing the TE bit to 0 in SCR does not affect the ERS flag, which retains its previous value.

Bits 3 to 0: These bits operate as in normal serial communication. For details see section 13.2.7, Serial Status Register (SSR). The setting conditions for transmit end (TEND), however, are modified as follows.

Bit 2

TEND	Description
0	<p>Transmission is in progress [Clearing conditions] Software reads TDRE while it is set to 1, then writes 0 in the TDRE flag.</p> <p>The DMAC or DTC writes data in TDR.</p>
1	<p>End of transmission [Setting conditions] (Initial value) The chip is reset or enters standby mode. The TE bit and FER/ERS bit are both cleared to 0 in SCR. TDRE is 1 and FER/ERS is 0 at a time 2.5 etu after the last bit of a 1-byte serial character is transmitted (normal transmission).</p>

Note: etu (Elementary time unit: the time for transfer of one bit)

14.2.3 Serial Mode Register (SMR)

The function of SMR bit 7 is modified in smart card interface mode. This change also causes a modification to the function of bits 1 and 0 in the serial control register (SCR).

Bit	7	6	5	4	3	2	1	0
	GM	CHR	PE	O/ \bar{E}	STOP	MP	CKS1	CKS0
Initial value	0	0	0	0	0	0	0	0
Read/Write	R/W	R/W	R/W	R/W	R/W	R/W	R/W	R/W

Bit 7—GSM Mode (GM): With the normal smart card interface, this bit is cleared to 0. Setting this bit to 1 selects GSM mode, an additional mode for controlling the timing for setting the TEND flag that indicates completion of transmission, and the type of clock output used. The details of the additional clock output control mode are specified by the CKE1 and CKE0 bits in the serial control register (SCR).

Bit 7

GM	Description
0	Normal smart card interface mode operation The TEND flag is set 12.5 etu after the beginning of the start bit. Clock output on/off control only. (Initial value)
1	GSM mode smart card interface mode operation The TEND flag is set 11.0 etu after the beginning of the start bit. Clock output on/off and fixed-high/fixed-low control.

Note: etu (Elementary time unit: the time for transfer of one bit)

Bits 6 to 0: These bits operate as in normal serial communication. For details see section 13.2.5, Serial Mode Register (SMR).

14.2.4 Serial Control Register (SCR)

The function of SCR bits 1 and 0 is modified in smart card interface mode

Bit	7	6	5	4	3	2	1	0
	TIE	RIE	TE	RE	MPIE	TEIE	CKE1	CKE0
Initial value	0	0	0	0	0	0	0	0
Read/Write	R/W	R/W	R/W	R/W	R/W	R/W	R/W	R/W

Bits 7 to 2: These bits operate as in normal serial communication. For details see section 13.2.6, Serial Control Register (SCR).

Bits 1 and 0—Clock Enable 1 and 0 (CKE1, CKE0): These bits select the SCI clock source and enable or disable clock output from the SCK pin. In smart card interface mode, it is possible to specify a fixed high level or fixed low level for the clock output, in addition to the usual switching between enabling and disabling of the clock output.

Bit 7 GM	Bit 1 CKE1	Bit 0 CKE0	Description
0	0	0	Internal clock/SCK pin is I/O port (Initial value)
		1	Internal clock/SCK pin is clock output
1	0	0	Internal clock/SCK pin is fixed at low output
		1	Internal clock/SCK pin is clock output
	1	0	Internal clock/SCK pin is fixed at high output
		1	Internal clock/SCK pin is clock output

14.3 Operation

14.3.1 Overview

The main features of the smart card interface are as follows.

- One frame consists of 8-bit data plus a parity bit.
- In transmission, a guard time of at least 2 etu (elementary time units: the time for transfer of one bit) is provided between the end of the parity bit and the start of the next frame.
- If a parity error is detected during reception, a low error signal level is output for a 1 etu period 10.5 etu after the start bit.
- If an error signal is detected during transmission, the same data is transmitted automatically after the elapse of 2 etu or longer.
- Only asynchronous communication is supported; there is no synchronous communication function.

14.3.2 Pin Connections

Figure 14.2 shows a pin connection diagram for the smart card interface.

In communication with a smart card, since both transmission and reception are carried out on a single data transmission line, the TxD pin and RxD pin should both be connected to this line. The data transmission line should be pulled up to V_{CC} with a resistor.

When the smart card uses the clock generated on the smart card interface, the SCK pin output is input to the CLK pin of the smart card. If the smart card uses an internal clock, this connection is unnecessary.

The reset signal should be output from one of the H8/3068F's generic ports.

In addition to these pin connections, power and ground connections will normally also be necessary.

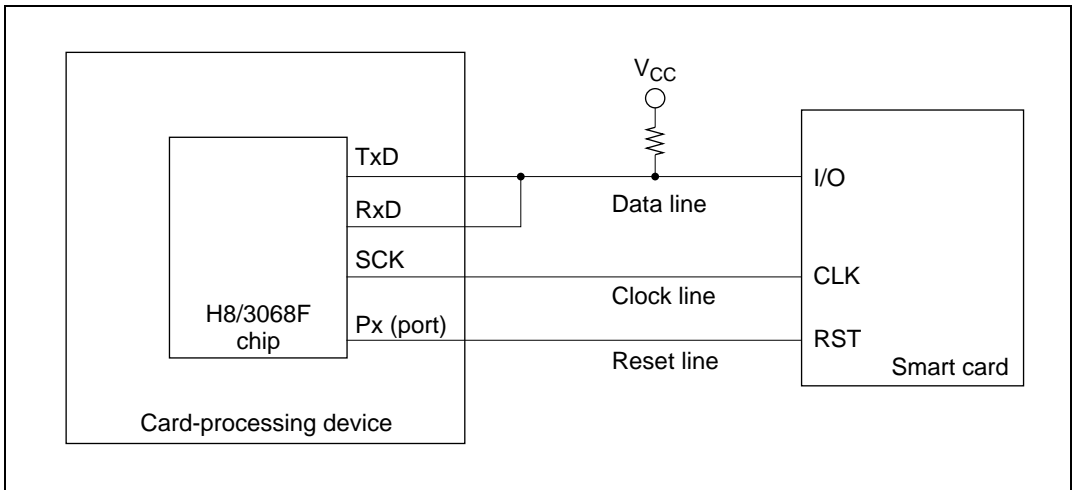

Figure 14.2 Smart Card Interface Connection Diagram

Note: A loop-back test can be performed by setting both RE and TE to 1 without connecting a smart card.

14.3.3 Data Format

Figure 14.3 shows the smart card interface data format. In reception in this mode, a parity check is carried out on each frame, and if an error is detected an error signal is sent back to the transmitting device to request retransmission of the data. In transmission, the error signal is sampled and the same data is retransmitted if the error signal is low.

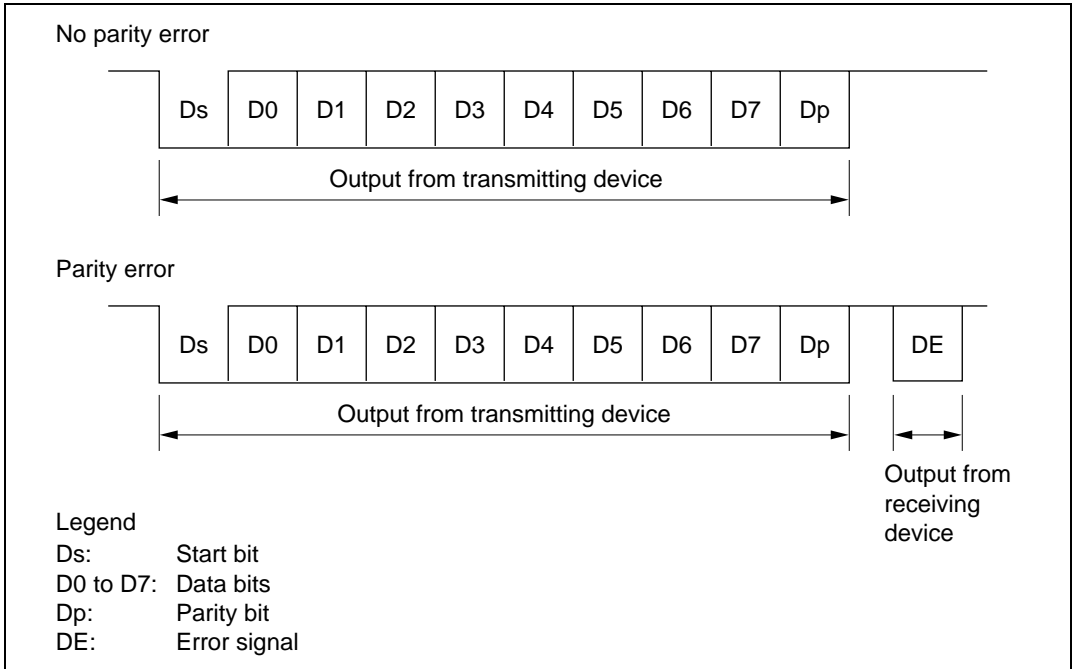

Figure 14.3 Smart Card Interface Data Format

The operating sequence is as follows.

1. When the data line is not in use it is in the high-impedance state, and is fixed high with a pull-up resistor.
2. The transmitting device starts transfer of one frame of data. The data frame starts with a start bit (Ds, low-level), followed by 8 data bits (D0 to D7) and a parity bit (Dp).
3. With the smart card interface, the data line then returns to the high-impedance state. The data line is pulled high with a pull-up resistor.
4. The receiving device carries out a parity check. If there is no parity error and the data is received normally, the receiving device waits for reception of the next data. If a parity error occurs, however, the receiving device outputs an error signal (DE, low-level) to request

retransmission of the data. After outputting the error signal for the prescribed length of time, the receiving device places the signal line in the high-impedance state again. The signal line is pulled high again by a pull-up resistor.

5. If the transmitting device does not receive an error signal, it proceeds to transmit the next data frame. If it receives an error signal, however, it returns to step 2 and transmits the same data again.

14.3.4 Register Settings

Table 14.3 shows a bit map of the registers used in the smart card interface. Bits indicated as 0 or 1 must be set to the value shown. The setting of other bits is described in this section.

Table 14.3 Smart Card Interface Register Settings

Register	Address* ¹	Bit							
		Bit 7	Bit 6	Bit 5	Bit 4	Bit 3	Bit 2	Bit 1	Bit 0
SMR	H'FFFB0	GM	0	1	O/ \bar{E}	1	0	CKS1	CKS0
BRR	H'FFFB1	BRR7	BRR6	BRR5	BRR4	BRR3	BRR2	BRR1	BRR0
SCR	H'FFFB2	TIE	RIE	TE	RE	0	0	CKE1* ²	CKE0
TDR	H'FFFB3	TDR7	TDR6	TDR5	TDR4	TDR3	TDR2	TDR1	TDR0
SSR	H'FFFB4	TDRE	RDRF	ORER	ERS	PER	TEND	0	0
RDR	H'FFFB5	RDR7	RDR6	RDR5	RDR4	RDR3	RDR2	RDR1	RDR0
SCMR	H'FFFB6	—	—	—	—	SDIR	SINV	—	SMIF

Notes: — Unused bit.

1. Lower 20 bits of the address in advanced mode.

2. When GM is cleared to 0 in SMR, the CKE1 bit must also be cleared to 0.

Serial Mode Register (SMR) Settings: Clear the GM bit to 0 when using the normal smart card interface mode, or set to 1 when using GSM mode. Clear the O/ \bar{E} bit to 0 if the smart card is of the direct convention type, or set to 1 if of the inverse convention type.

Bits CKS1 and CKS0 select the clock source of the built-in baud rate generator. See section 14.3.5, Clock.

Bit Rate Register (BRR) Settings: BRR is used to set the bit rate. See section 14.3.5, Clock, for the method of calculating the value to be set.

Serial Control Register (SCR) Settings: The TIE, RIE, TE, and RE bits have their normal serial communication functions. See section 13, Serial Communication Interface, for details. The CKE1 and CKE0 bits specify clock output. To disable clock output, clear these bits to 00; to enable

clock output, set these bits to 01. Clock output is not performed when the GM bit is set to 1 in SMR. Clock output can also be fixed low or high.

Smart Card Mode Register (SCMR) Settings: Clear both the SDIR bit and SINV bit cleared to 0 if the smart card is of the direct convention type, and set both to 1 if of the inverse convention type. To use the smart card interface, set the SMIF bit to 1.

The register settings and examples of starting character waveforms are shown below for two smart cards, one following the direct convention and one the inverse convention.

1. Direct Convention (SDIR = SINV = O/\bar{E} = 0)

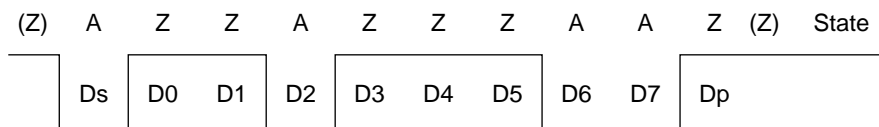

With the direct convention type, the logic 0 level corresponds to state Z and the logic 1 level to state A, and transfer is performed in LSB-first order. In the example above, the first character data is H'3B. The parity bit is 1, following the even parity rule designated for smart cards.

2. Indirect Convention (SDIR = SINV = O/\bar{E} = 1)

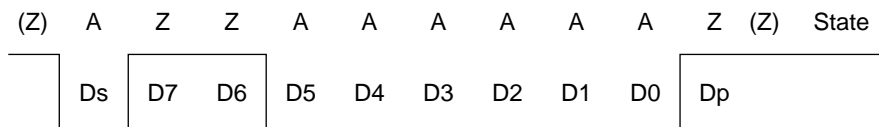

With the indirect convention type, the logic 1 level corresponds to state Z and the logic 0 level to state A, and transfer is performed in MSB-first order. In the example above, the first character data is H'3F. The parity bit is 0, corresponding to state Z, following the even parity rule designated for smart cards.

In the H8/3068F, inversion specified by the SINV bit applies only to the data bits, D7 to D0. For parity bit inversion, the O/\bar{E} bit in SMR must be set to odd parity mode. This applies to both transmission and reception.

14.3.5 Clock

Only an internal clock generated by the on-chip baud rate generator can be used as the transmit/receive clock for the smart card interface. The bit rate is set with the bit rate register (BRR) and the CKS1 and CKS0 bits in the serial mode register (SMR). The equation for calculating the bit rate is shown below. Table 14.5 shows some sample bit rates.

If clock output is selected with CKE0 set to 1, a clock with a frequency of 372 times the bit rate is output from the SCK pin.

$$B = \frac{\phi}{1488 \times 2^{2n-1} \times (N + 1)} \times 10^6$$

where, N: BRR setting ($0 \leq N \leq 255$)

B: Bit rate (bit/s)

ϕ : Operating frequency (MHz)

n: See table 14.4

Table 14.4 n-Values of CKS1 and CKS0 Settings

n	CKS1	CKS0
0	0	0
1		1
2	1	0
3		1

Note: * If the gear function is used to divide the clock frequency, use the divided frequency to calculate the bit rate. The equation above applies directly to 1/1 frequency division.

Table 14.5 Bit Rates (bits/s) for Various BRR Settings (When n = 0)

N	ϕ (MHz)						
	7.1424	10.00	10.7136	13.00	14.2848	16.00	18.00
0	9600.0	13440.9	14400.0	17473.1	19200.0	21505.4	24193.5
1	4800.0	6720.4	7200.0	8736.6	9600.0	10752.7	12096.8
2	3200.0	4480.3	4800.0	5824.4	6400.0	7168.5	8064.5

Note: Bit rates are rounded off to one decimal place.

The following equation calculates the bit rate register (BRR) setting from the operating frequency and bit rate. N is an integer from 0 to 255, specifying the value with the smaller error.

$$N = \frac{\phi}{1488 \times 2^{2n-1} \times B} \times 10^6 - 1$$

Table 14.6 BRR Settings for Typical Bit Rates (bits/s) (When n = 0)

bit/s	ϕ (MHz)													
	7.1424		10.00		10.7136		13.00		14.2848		16.00		18.00	
	N	Error	N	Error	N	Error	N	Error	N	Error	N	Error	N	Error
9600	0	0.00	1	30	1	25	1	8.99	1	0.00	1	12.01	2	15.99

Table 14.7 Maximum Bit Rates for Various Frequencies (Smart Card Interface Mode)

ϕ (MHz)	Maximum Bit Rate (bits/s)	N	n
7.1424	9600	0	0
10.00	13441	0	0
10.7136	14400	0	0
13.00	17473	0	0
14.2848	19200	0	0
16.00	21505	0	0
18.00	24194	0	0

The bit rate error is given by the following equation:

$$\text{Error (\%)} = \left(\frac{\phi}{1488 \times 2^{2n-1} \times B \times (N + 1)} \times 10^6 - 1 \right) \times 100$$

14.3.6 Transmitting and Receiving Data

Initialization: Before transmitting or receiving data, the smart card interface must be initialized as described below. Initialization is also necessary when switching from transmit mode to receive mode, or vice versa.

1. Clear the TE and RE bits to 0 in the serial control register (SCR).
2. Clear error flags FER/ERS, PER, and ORER to 0 in the serial status register (SSR).
3. Set the parity bit (O/\bar{E}) and baud rate generator select bits (CKS1 and CKS0) in the serial mode register (SMR). Clear the C/\bar{A} , CHR, and MP bits to 0, and set the STOP and PE bits to 1.
4. Set the SMIF, SDIR, and SINV bits in the smart card mode register (SCMR).

When the SMIF bit is set to 1, the TxD pin and RxD pin are both switched from port to SCI pin functions and go to the high-impedance state.

5. Set a value corresponding to the desired bit rate in the bit rate register (BRR).
6. Set the CKE0 bit in SCR. Clear the TIE, RIE, TE, RE, MPIE, TEIE, and CKE1 bits to 0. If the CKE0 bit is set to 1, the clock is output from the SCK pin.
7. Wait at least one bit interval, then set the TIE, RIE, TE, and RE bits in SCR. Do not set the TE bit and RE bit at the same time, except for self-diagnosis.

Transmitting Serial Data: As data transmission in smart card mode involves error signal sampling and retransmission processing, the processing procedure is different from that for the normal SCI. Figure 14.5 shows a sample transmission processing flowchart.

1. Perform smart card interface mode initialization as described in Initialization above.
2. Check that the FER/ERS error flag is cleared to 0 in SSR.
3. Repeat steps 2 and 3 until it can be confirmed that the TEND flag is set to 1 in SSR.
4. Write the transmit data in TDR, clear the TDRE flag to 0, and perform the transmit operation. The TEND flag is cleared to 0.
5. To continue transmitting data, go back to step 2.
6. To end transmission, clear the TE bit to 0.

The above processing may include interrupt handling DMA transfer.

If transmission ends and the TEND flag is set to 1 while the TIE bit is set to 1 and interrupt requests are enabled, a transmit-data-empty interrupt (TXI) will be requested. If an error occurs in transmission and the ERS flag is set to 1 while the RIE bit is set to 1 and interrupt requests are enabled, a transmit/receive-error interrupt (ERI) will be requested.

The timing of TEND flag setting depends on the GM bit in SMR (see figure 14.4).

If the TXI interrupt activates the DMAC, the number of bytes designated in the DMAC can be transmitted automatically, including automatic retransmission.

For details, see Interrupt Operations and Data Transfer by DMAC in this section.

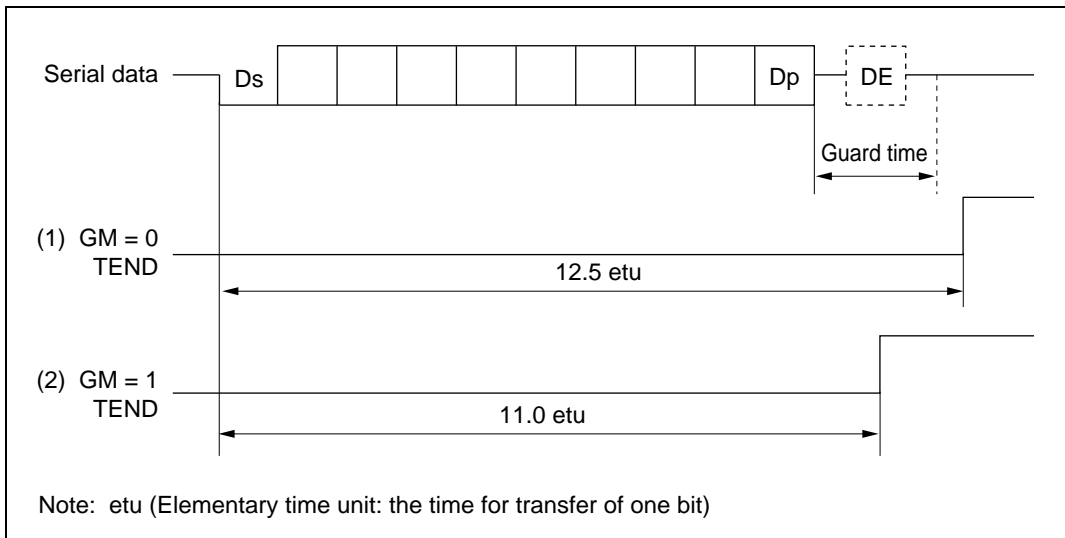

Figure 14.4 Timing of TEND Flag Setting

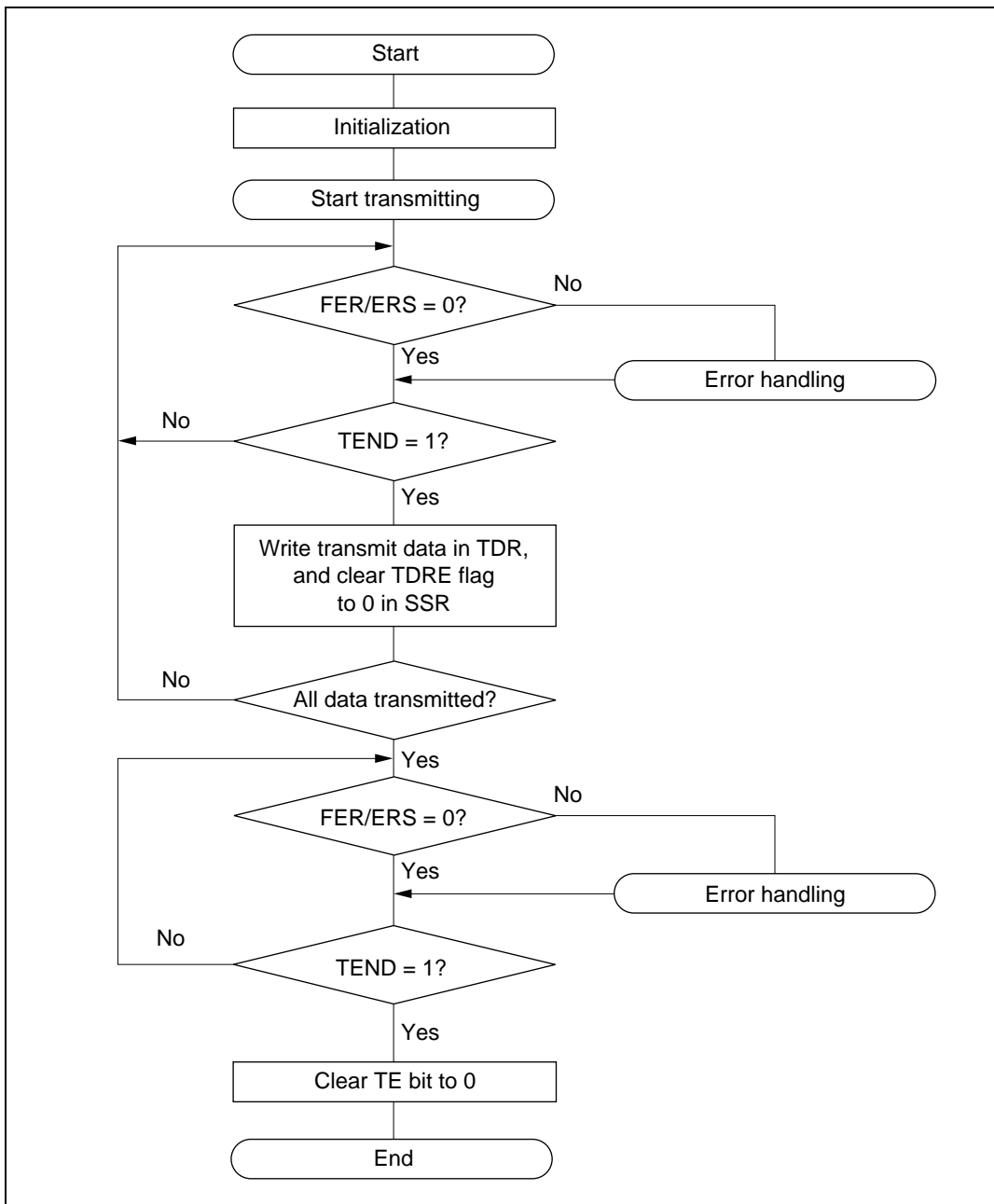

Figure 14.5 Sample Transmission Processing Flowchart

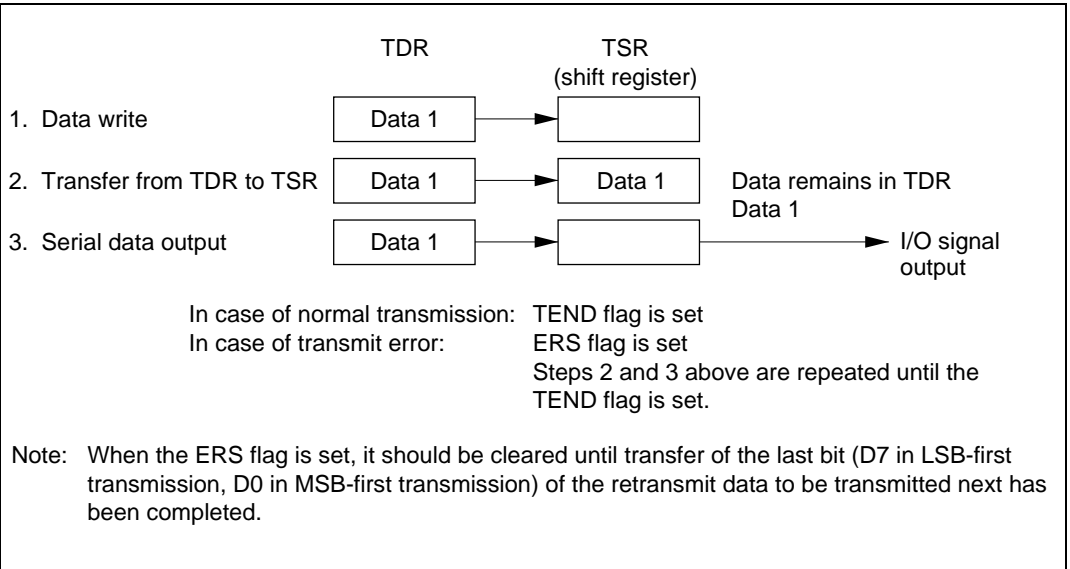

Figure 14.6 Relation Between Transmit Operation and Internal Registers

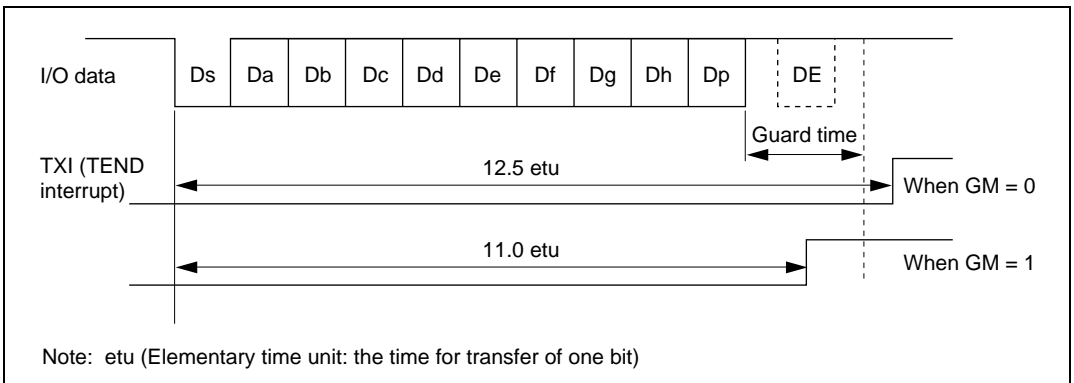

Figure 14.7 Timing of TEND Flag Setting

Receiving Serial Data: Data reception in smart card mode uses the same processing procedure as for the normal SCI. Figure 14.8 shows a sample reception processing flowchart.

1. Perform smart card interface mode initialization as described in Initialization above.
2. Check that the ORER flag and PER flag are cleared to 0 in SSR. If either is set, perform the appropriate receive error handling, then clear both the ORER and the PER flag to 0.
3. Repeat steps 2 and 3 until it can be confirmed that the RDRF flag is set to 1.
4. Read the receive data from RDR.

5. To continue receiving data, clear the RDRF flag to 0 and go back to step 2.
6. To end reception, clear the RE bit to 0.

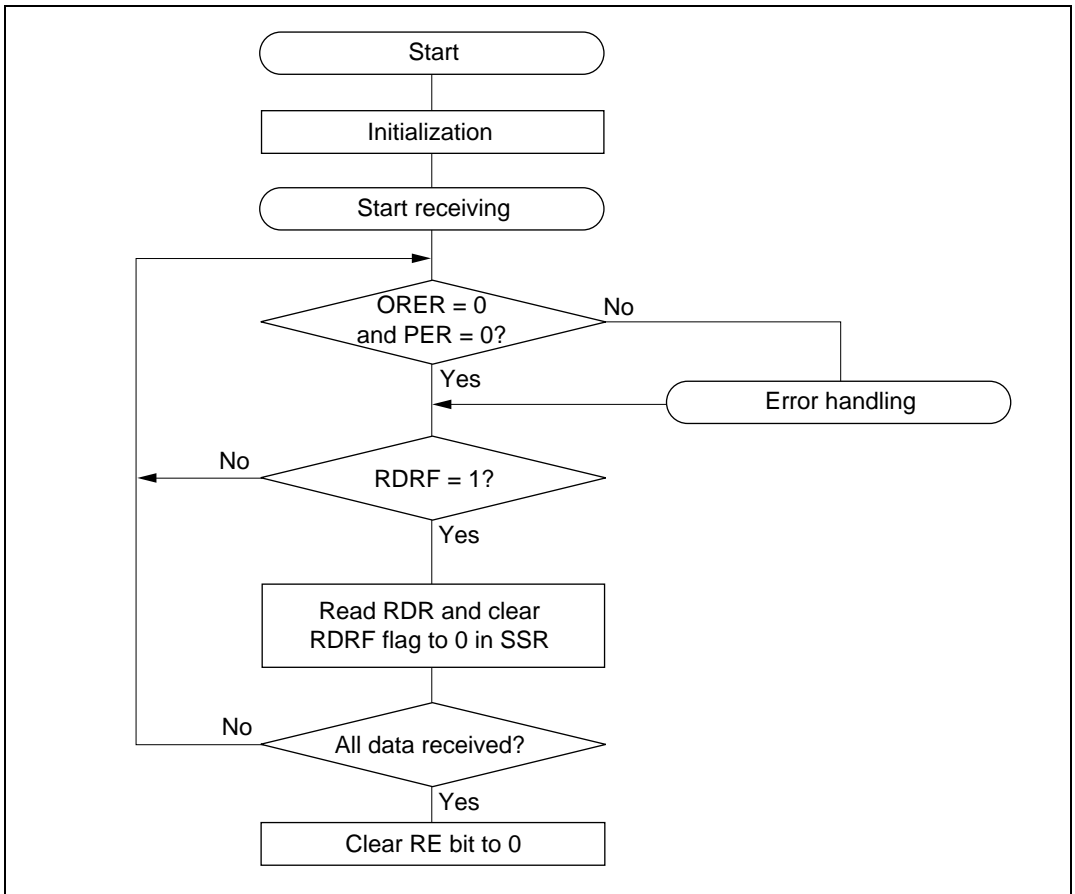

Figure 14.8 Sample Reception Processing Flowchart

The above procedure may include interrupt handling and DMA transfer.

If reception ends and the RDRF flag is set to 1 while the RIE bit is set to 1 and interrupt requests are enabled, a receive-data-full interrupt (RXI) will be requested. If an error occurs in reception and either the ORER flag or the PER flag is set to 1, a transmit/receive-error interrupt (ERI) will be requested.

If the RXI interrupt activates the DMAC, the number of bytes designated in the DMAC will be transferred, skipping receive data in which an error occurred.

For details, see Interrupt Operations and Data Transfer by DMAC in this section.

If a parity error occurs during reception and the PER flag is set to 1, the received data is transferred to RDR, so the erroneous data can be read.

Switching Modes: When switching from receive mode to transmit mode, first confirm that the receive operation has been completed, then start from initialization, clearing RE to 0 and setting TE to 1. The RDRF, PER, or ORER flag can be used to check that the receive operation has been completed.

When switching from transmit mode to receive mode, first confirm that the transmit operation has been completed, then start from initialization, clearing TE to 0 and setting RE to 1. The TEND flag can be used to check that the transmit operation has been completed.

Fixing Clock Output: When the GM bit is set to 1 in SMR, clock output can be fixed by means of the CKE1 and CKE0 bits in SCR. The minimum clock pulse width can be set to the specified width in this case.

Figure 14.9 shows the timing for fixing clock output. In this example, GM = 1, CKE1 = 0, and the CKE0 bit is controlled.

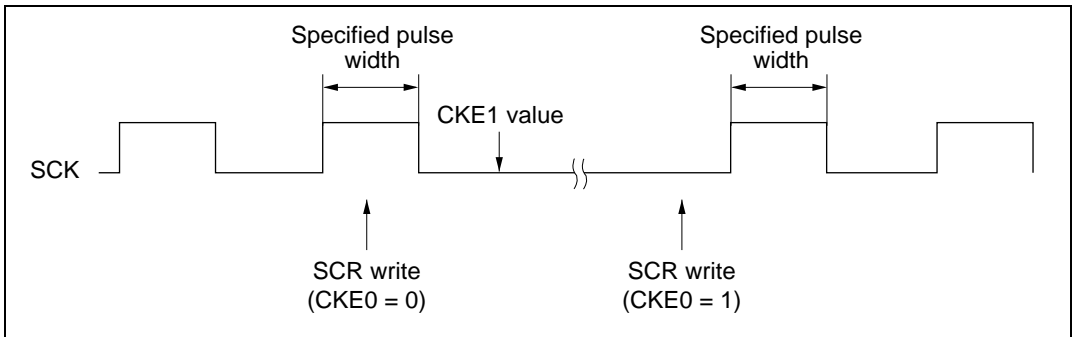

Figure 14.9 Timing for Fixing Clock Output

Interrupt Operations: The smart card interface has three interrupt sources: transmit-data-empty (TXI), transmit/receive-error (ERI), and receive-data-full (RXI). The transmit-end interrupt request (TEI) is not available in smart card mode.

A TXI interrupt is requested when the TEND flag is set to 1 in SSR. An RXI interrupt is requested when the RDRF flag is set to 1 in SSR. An ERI interrupt is requested when the ORER, PER, or ERS flag is set to 1 in SSR. These relationships are shown in table 14.8.

Table 14.8 Smart Card Interface Mode Operating States and Interrupt Sources

Operating State		Flag	Enable Bit	Interrupt Source	DMAC Activation
Transmit Mode	Normal operation	TEND	TIE	TXI	Available
	Error	ERS	RIE	ERI	Not available
Receive Mode	Normal operation	RDRF	RIE	RXI	Available
	Error	PER, ORER	RIE	ERI	Not available

Data Transfer by DMAC: The DMAC can be used to transmit and receive data in smart card mode, as in normal SCI operations. In transmit mode, when the TEND flag is set to 1 in SSR, the TDRE flag is set simultaneously, generating a TXI interrupt. If the TXI request is designated beforehand as a DMAC activation source, the DMAC will be activated by the TXI request and will transfer the next transmit data. This data transfer by the DMAC automatically clears the TDRE and TEND flags to 0. In the event of an error, the SCI automatically retransmits the same data, keeping the TEND flag cleared to 0 so that the DMAC is not activated. The SCI and DMAC will therefore automatically transmit the designated number of bytes, including retransmission when an error occurs. When an error occurs, the ERS flag is not cleared automatically, so the RIE bit should be set to 1 to enable the error to generate an ERI request, and the ERI interrupt handler should clear ERS.

When using the DMAC to transmit or receive, first set up and enable the DMAC, then make SCI settings. DMAC settings are described in section 7, DMA controller.

In receive operations, an RXI interrupt is requested when the RDRF flag is set to 1 in SSR. If the RXI request is designated beforehand as a DMAC activation source, the DMAC will be activated by the RXI request and will transfer the received data. This data transfer by the DMAC automatically clears the RDRF flag to 0. When an error occurs, the RDRF flag is not set and an error flag is set instead. The DMAC is not activated. The ERI interrupt request is directed to the CPU. The ERI interrupt handler should clear the error flags.

Examples of Operation in GSM Mode: When switching between smart card interface mode and software standby mode, use the following procedures to maintain the clock duty cycle.

- Switching from smart card interface mode to software standby mode
 1. Set the P9₄ data register (DR) and data direction register (DDR) to the values for the fixed output state in software standby mode.
 2. Write 0 in the TE and RE bits in the serial control register (SCR) to stop transmit/receive operations. At the same time, set the CKE1 bit to the value for the fixed output state in software standby mode.
 3. Write 0 in the CKE0 bit in SCR to stop the clock.
 4. Wait for one serial clock cycle. During this period, the duty cycle is preserved and clock output is fixed at the specified level.
 5. Write H'00 in the serial mode register (SMR) and smart card mode register (SCMR).
 6. Make the transition to the software standby state.

- Returning from software standby mode to smart card interface mode
 1. Clear the software standby state.
 2. Set the CKE1 bit in SCR to the value for the fixed output state at the start of software standby (the current P9₄ pin state).
 3. Set smart card interface mode and output the clock. Clock signal generation is started with the normal duty cycle.

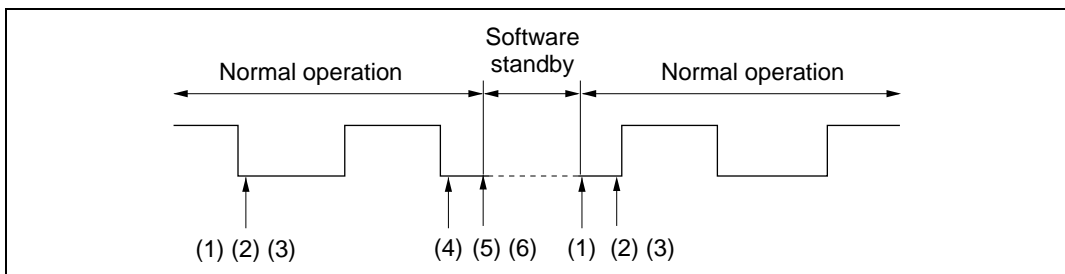

Figure 14.10 Procedure for Stopping and Restarting the Clock

Use the following procedure to secure the clock duty cycle after powering on.

1. The initial state is port input and high impedance. Use pull-up or pull-down resistors to fix the potential.
2. Fix at the output specified by the CKE1 bit in SCR.
3. Set SMR and SCMR, and switch to smart card interface mode operation.
4. Set the CKE0 bit to 1 in SCR to start clock output.

14.4 Usage Notes

The following points should be noted when using the SCI as a smart card interface.

Receive Data Sampling Timing and Receive Margin in Smart Card Interface Mode: In smart card interface mode, the SCI operates on a base clock with a frequency of 372 times the transfer rate. In reception, the SCI synchronizes internally with the fall of the start bit, which it samples on the base clock. Receive data is latched at the rising edge of the 186th base clock pulse. The timing is shown in figure 14.11.

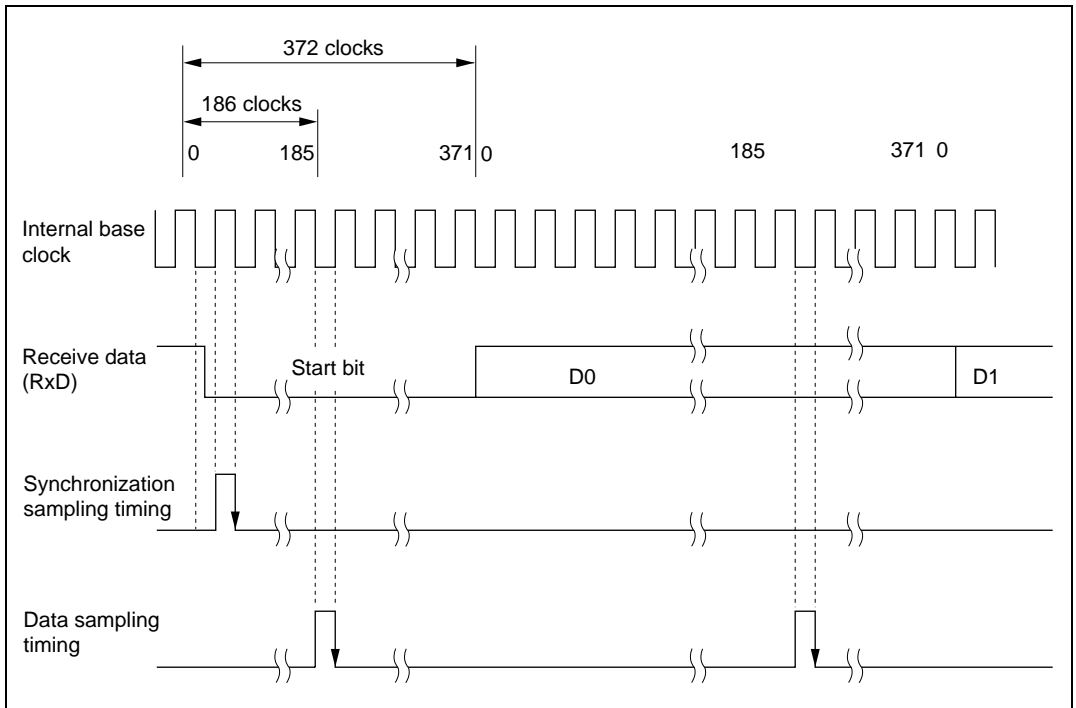

Figure 14.11 Receive Data Sampling Timing in Smart Card Interface Mode

The receive margin can therefore be expressed as follows.

Receive margin in smart card interface mode:

$$M = \left| \left(0.5 - \frac{1}{2N} \right) - (L - 0.5) F - \frac{|D - 0.5|}{N} (1 + F) \right| \times 100\%$$

M: Receive margin (%)

N: Ratio of clock frequency to bit rate (N = 372)

D: Clock duty cycle (L = 0 to 1.0)

L: Frame length (L = 10)

F: Absolute deviation of clock frequency

From the above equation, if F = 0 and D = 0.5, the receive margin is as follows.

When D = 0.5 and F = 0:

$$\begin{aligned} M &= (0.5 - 1/2 \times 372) \times 100\% \\ &= 49.866\% \end{aligned}$$

Retransmission: Retransmission is performed by the SCI in receive mode and transmit mode as described below.

- Retransmission when SCI is in Receive Mode

Figure 14.12 illustrates retransmission when the SCI is in receive mode.

1. If an error is found when the received parity bit is checked, the PER bit is automatically set to 1. If the RIE bit in SCR is set to the enable state, an ERI interrupt is requested. The PER bit should be cleared to 0 in SSR before the next parity bit sampling timing.
2. The RDRF bit in SSR is not set for the frame in which the error has occurred.
3. If no error is found when the received parity bit is checked, the PER bit is not set to 1 in SSR.
4. If no error is found when the received parity bit is checked, the receive operation is assumed to have been completed normally, and the RDRF bit is automatically set to 1 in SSR. If the RIE bit in SCR is set to the enable state, an RXI interrupt is requested. If RXI is enabled as a DMA transfer activation source, the RDR contents can be read automatically. When the DMAC reads the RDR data, the RDRF flag is automatically cleared to 0.
5. When a normal frame is received, the data pin is held in the high-impedance state at the error signal transmission timing.

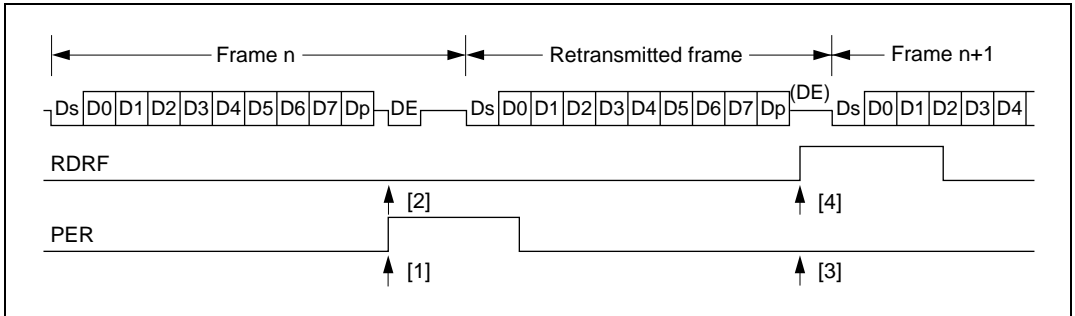

Figure 14.12 Retransmission in SCI Receive Mode

- Retransmission when SCI is in Transmit Mode

Figure 14.13 illustrates retransmission when the SCI is in transmit mode.

- If an error signal is sent back from the receiving device after transmission of one frame is completed, the FER/ERS bit is set to 1 in SSR. If the RIE bit in SCR is set to the enable state, an ERI interrupt is requested. The ERS bit should be cleared to 0 in SSR before the next parity bit sampling timing.
- The TEND bit in SSR is not set for the frame for which the error signal was received.
- If an error signal is not sent back from the receiving device, the ERS flag is not set in SSR.
- If an error signal is not sent back from the receiving device, transmission of one frame, including retransmission, is assumed to have been completed, and the TEND bit is set to 1 in SSR. If the TIE bit in SCR is set to the enable state, a TXI interrupt is requested. If TXI is enabled as a DMA transfer activation source, the next data can be written in TDR automatically. When the DMAC writes data in TDR, the TDRE bit is automatically cleared to 0.

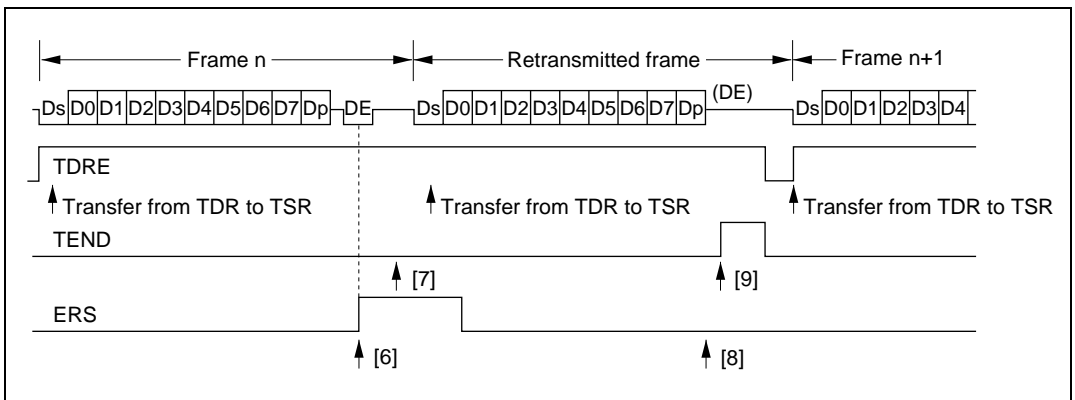

Figure 14.13 Retransmission in SCI Transmit Mode

Section 15 A/D Converter

15.1 Overview

The H8/3068F includes a 10-bit successive-approximations A/D converter with a selection of up to eight analog input channels.

When the A/D converter is not used, it can be halted independently to conserve power. For details see section 20.6, Module Standby Function.

15.1.1 Features

A/D converter features are listed below.

- 10-bit resolution
- Eight input channels
- Selectable analog conversion voltage range
The analog voltage conversion range can be programmed by input of an analog reference voltage at the V_{REF} pin.
- High-speed conversion
Conversion time: maximum 3.5 μ s per channel (with 20 MHz system clock)
- Two conversion modes
Single mode: A/D conversion of one channel
Scan mode: continuous conversion on one to four channels
- Four 16-bit data registers
A/D conversion results are transferred for storage into data registers corresponding to the channels.
- Sample-and-hold function
- Three conversion start sources
The A/D converter can be activated by software, an external trigger, or an 8-bit timer compare match.
- A/D interrupt requested at end of conversion
At the end of A/D conversion, an A/D end interrupt (ADI) can be requested.
- DMA controller (DMAC) activation
The DMAC can be activated at the end of A/D conversion.

15.1.2 Block Diagram

Figure 15.1 shows a block diagram of the A/D converter.

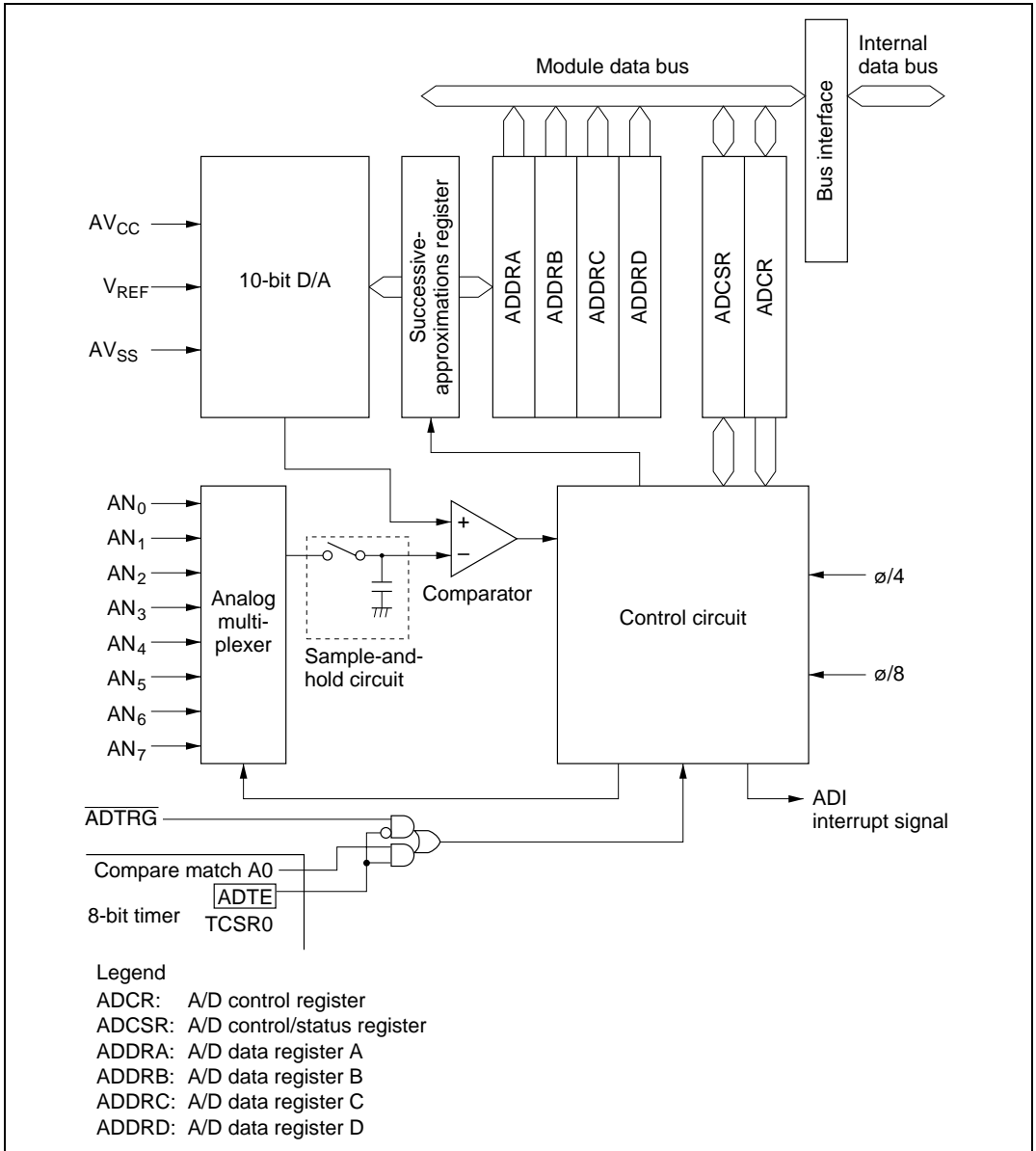

Figure 15.1 A/D Converter Block Diagram

15.1.3 Input Pins

Table 15.1 summarizes the A/D converter's input pins. The eight analog input pins are divided into two groups: group 0 (AN₀ to AN₃), and group 1 (AN₄ to AN₇). AV_{CC} and AV_{SS} are the power supply for the analog circuits in the A/D converter. V_{REF} is the A/D conversion reference voltage.

Table 15.1 A/D Converter Pins

Pin Name	Abbreviation	I/O	Function
Analog power supply pin	AV _{CC}	Input	Analog power supply
Analog ground pin	AV _{SS}	Input	Analog ground and reference voltage
Reference voltage pin	V _{REF}	Input	Analog reference voltage
Analog input pin 0	AN ₀	Input	Group 0 analog inputs
Analog input pin 1	AN ₁	Input	
Analog input pin 2	AN ₂	Input	
Analog input pin 3	AN ₃	Input	
Analog input pin 4	AN ₄	Input	Group 1 analog inputs
Analog input pin 5	AN ₅	Input	
Analog input pin 6	AN ₆	Input	
Analog input pin 7	AN ₇	Input	
A/D external trigger input pin	$\overline{\text{ADTRG}}$	Input	External trigger input for starting A/D conversion

15.1.4 Register Configuration

Table 15.2 summarizes the A/D converter's registers.

Table 15.2 A/D Converter Registers

Address* ¹	Name	Abbreviation	R/W	Initial Value
H'FFFE0	A/D data register A H	ADDRAH	R	H'00
H'FFFE1	A/D data register A L	ADDRAL	R	H'00
H'FFFE2	A/D data register B H	ADDRBH	R	H'00
H'FFFE3	A/D data register B L	ADDRBL	R	H'00
H'FFFE4	A/D data register C H	ADDRCH	R	H'00
H'FFFE5	A/D data register C L	ADDRCL	R	H'00
H'FFFE6	A/D data register D H	ADDRDH	R	H'00
H'FFFE7	A/D data register D L	ADDRDL	R	H'00
H'FFFE8	A/D control/status register	ADCSR	R/(W)* ²	H'00
H'FFFE9	A/D control register	ADCR	R/W	H'7E

Notes: 1. Lower 20 bits of the address in advanced mode.

2. Only 0 can be written in bit 7, to clear the flag.

15.2 Register Descriptions

15.2.1 A/D Data Registers A to D (ADDRA to ADDR4)

Bit	15	14	13	12	11	10	9	8	7	6	5	4	3	2	1	0
ADDR _n	AD9	AD8	AD7	AD6	AD5	AD4	AD3	AD2	AD1	AD0	—	—	—	—	—	—
Initial value	0	0	0	0	0	0	0	0	0	0	0	0	0	0	0	0
Read/Write (n = A to D)	R	R	R	R	R	R	R	R	R	R	R	R	R	R	R	R
	A/D conversion data 10-bit data giving an A/D conversion result										Reserved bits					

The four A/D data registers (ADDRA to ADDR4) are 16-bit read-only registers that store the results of A/D conversion.

An A/D conversion produces 10-bit data, which is transferred for storage into the A/D data register corresponding to the selected channel. The upper 8 bits of the result are stored in the upper byte of the A/D data register. The lower 2 bits are stored in the lower byte. Bits 5 to 0 of an A/D data register are reserved bits that are always read as 0. Table 15.3 indicates the pairings of analog input channels and A/D data registers.

The CPU can always read and write the A/D data registers. The upper byte can be read directly, but the lower byte is read through a temporary register (TEMP). For details see section 15.3, CPU Interface.

The A/D data registers are initialized to H'0000 by a reset and in standby mode.

Table 15.3 Analog Input Channels and A/D Data Registers

Analog Input Channel		
Group 0	Group 1	A/D Data Register
AN ₀	AN ₄	ADDRA
AN ₁	AN ₅	ADDRB
AN ₂	AN ₆	ADDRC
AN ₃	AN ₇	ADDRD

15.2.2 A/D Control/Status Register (ADCSR)

Bit	7	6	5	4	3	2	1	0
	ADF	ADIE	ADST	SCAN	CKS	CH2	CH1	CH0
Initial value	0	0	0	0	0	0	0	0
Read/Write	R/(W)*	R/W	R/W	R/W	R/W	R/W	R/W	R/W

A/D end flag
 Indicates end of A/D conversion

A/D interrupt enable
 Enables and disables A/D end interrupts

A/D start
 Starts or stops A/D conversion

Scan mode
 Selects single mode or scan mode

Clock select
 Selects the A/D conversion time

Channel select 2 to 0
 These bits select analog input channels

Note: * Only 0 can be written, to clear the flag.

ADCSR is an 8-bit readable/writable register that selects the mode and controls the A/D converter. ADCSR is initialized to H'00 by a reset and in standby mode.

Bit 7—A/D End Flag (ADF): Indicates the end of A/D conversion.

Bit 7 ADF	Description	
0	[Clearing condition] Read ADF when ADF =1, then write 0 in ADF. DMAC activated by ADI interrupt.	(Initial value)
1	[Setting conditions] Single mode: A/D conversion ends Scan mode: A/D conversion ends in all selected channels	

Bit 6—A/D Interrupt Enable (ADIE): Enables or disables the interrupt (ADI) requested at the end of A/D conversion.

Bit 6 ADIE	Description	
0	A/D end interrupt request (ADI) is disabled	(Initial value)
1	A/D end interrupt request (ADI) is enabled	

Bit 5—A/D Start (ADST): Starts or stops A/D conversion. The ADST bit remains set to 1 during A/D conversion. It can also be set to 1 by external trigger input at the $\overline{\text{ADTRG}}$ pin, or by an 8-bit timer compare match.

Bit 5 ADST	Description	
0	A/D conversion is stopped	(Initial value)
1	Single mode: A/D conversion starts; ADST is automatically cleared to 0 when conversion ends. Scan mode: A/D conversion starts and continues, cycling among the selected channels, until ADST is cleared to 0 by software, by a reset, or by a transition to standby mode.	

Bit 4—Scan Mode (SCAN): Selects single mode or scan mode. For further information on operation in these modes, see section 15.4, Operation. Clear the ADST bit to 0 before switching the conversion mode.

Bit 4 SCAN	Description	
0	Single mode	(Initial value)
1	Scan mode	

Bit 3—Clock Select (CKS): Selects the A/D conversion time. Clear the ADST bit to 0 before switching the conversion time.

Bit 3 CKS	Description	
0	Conversion time = 134 states (maximum)	(Initial value)
1	Conversion time = 70 states (maximum)	

Bits 2 to 0—Channel Select 2 to 0 (CH2 to CH0): These bits and the SCAN bit select the analog input channels. Clear the ADST bit to 0 before changing the channel selection.

Group Selection	Channel Selection		Description	
	CH1	CH0	Single Mode	Scan Mode
0	0	0	AN ₀ (Initial value)	AN ₀
		1	AN ₁	AN ₀ , AN ₁
	1	0	AN ₂	AN ₀ to AN ₂
		1	AN ₃	AN ₀ to AN ₃
1	0	0	AN ₄	AN ₄
		1	AN ₅	AN ₄ , AN ₅
	1	0	AN ₆	AN ₄ to AN ₆
		1	AN ₇	AN ₄ to AN ₇

15.2.3 A/D Control Register (ADCR)

Bit	7	6	5	4	3	2	1	0
	TRGE	—	—	—	—	—	—	—
Initial value	0	1	1	1	1	1	1	0
Read/Write	R/W	—	—	—	—	—	—	R/W

Reserved bits

Trigger enable

Enables or disables starting of A/D conversion by an external trigger or 8-bit timer compare match

ADCR is an 8-bit readable/writable register that enables or disables starting of A/D conversion by external trigger input or an 8-bit timer compare match signal. ADCR is initialized to H'7F by a reset and in standby mode.

Bit 7—Trigger Enable (TRGE): Enables or disables starting of A/D conversion by an external trigger or 8-bit timer compare match.

Bit 7

TRGE	Description	
0	Starting of A/D conversion by an external trigger or 8-bit timer compare match is disabled	(Initial value)
1	A/D conversion is started at the falling edge of the external trigger signal (ADTRG) or by an 8-bit timer compare match	

External trigger pin and 8-bit timer selection are performed by the 8-bit timer. For details, see section 10, 8-Bit Timers.

Bits 6 to 1—Reserved: These bits cannot be modified and are always read as 1.

Bit 0—Reserved: This bit can be read or written, but must not be set to 1.

15.3 CPU Interface

ADDRA to ADDR D are 16-bit registers, but they are connected to the CPU by an 8-bit data bus. Therefore, although the upper byte can be accessed directly by the CPU, the lower byte is read through an 8-bit temporary register (TEMP).

An A/D data register is read as follows. When the upper byte is read, the upper-byte value is transferred directly to the CPU and the lower-byte value is transferred into TEMP. Next, when the lower byte is read, the TEMP contents are transferred to the CPU.

When reading an A/D data register, always read the upper byte before the lower byte. It is possible to read only the upper byte, but if only the lower byte is read, incorrect data may be obtained.

Figure 15.2 shows the data flow for access to an A/D data register.

15.4 Operation

The A/D converter operates by successive approximations with 10-bit resolution. It has two operating modes: single mode and scan mode.

15.4.1 Single Mode (SCAN = 0)

Single mode should be selected when only one A/D conversion on one channel is required. A/D conversion starts when the ADST bit is set to 1 by software, or by external trigger input. The ADST bit remains set to 1 during A/D conversion and is automatically cleared to 0 when conversion ends.

When conversion ends the ADF bit is set to 1. If the ADIE bit is also set to 1, an ADI interrupt is requested at this time. To clear the ADF flag to 0, first read ADCSR, then write 0 in ADF.

When the mode or analog input channel must be switched during analog conversion, to prevent incorrect operation, first clear the ADST bit to 0 in ADCSR to halt A/D conversion. After making the necessary changes, set the ADST bit to 1 to start A/D conversion again. The ADST bit can be set at the same time as the mode or channel is changed.

Typical operations when channel 1 (AN₁) is selected in single mode are described next.

Figure 15.3 shows a timing diagram for this example.

1. Single mode is selected (SCAN = 0), input channel AN₁ is selected (CH2 = CH1 = 0, CH0 = 1), the A/D interrupt is enabled (ADIE = 1), and A/D conversion is started (ADST = 1).
2. When A/D conversion is completed, the result is transferred into ADDR_B. At the same time the ADF flag is set to 1, the ADST bit is cleared to 0, and the A/D converter becomes idle.
3. Since ADF = 1 and ADIE = 1, an ADI interrupt is requested.
4. The A/D interrupt handling routine starts.
5. The routine reads ADCSR, then writes 0 in the ADF flag.
6. The routine reads and processes the conversion result (ADDR_B).
7. Execution of the A/D interrupt handling routine ends. After that, if the ADST bit is set to 1, A/D conversion starts again and steps 2 to 7 are repeated.

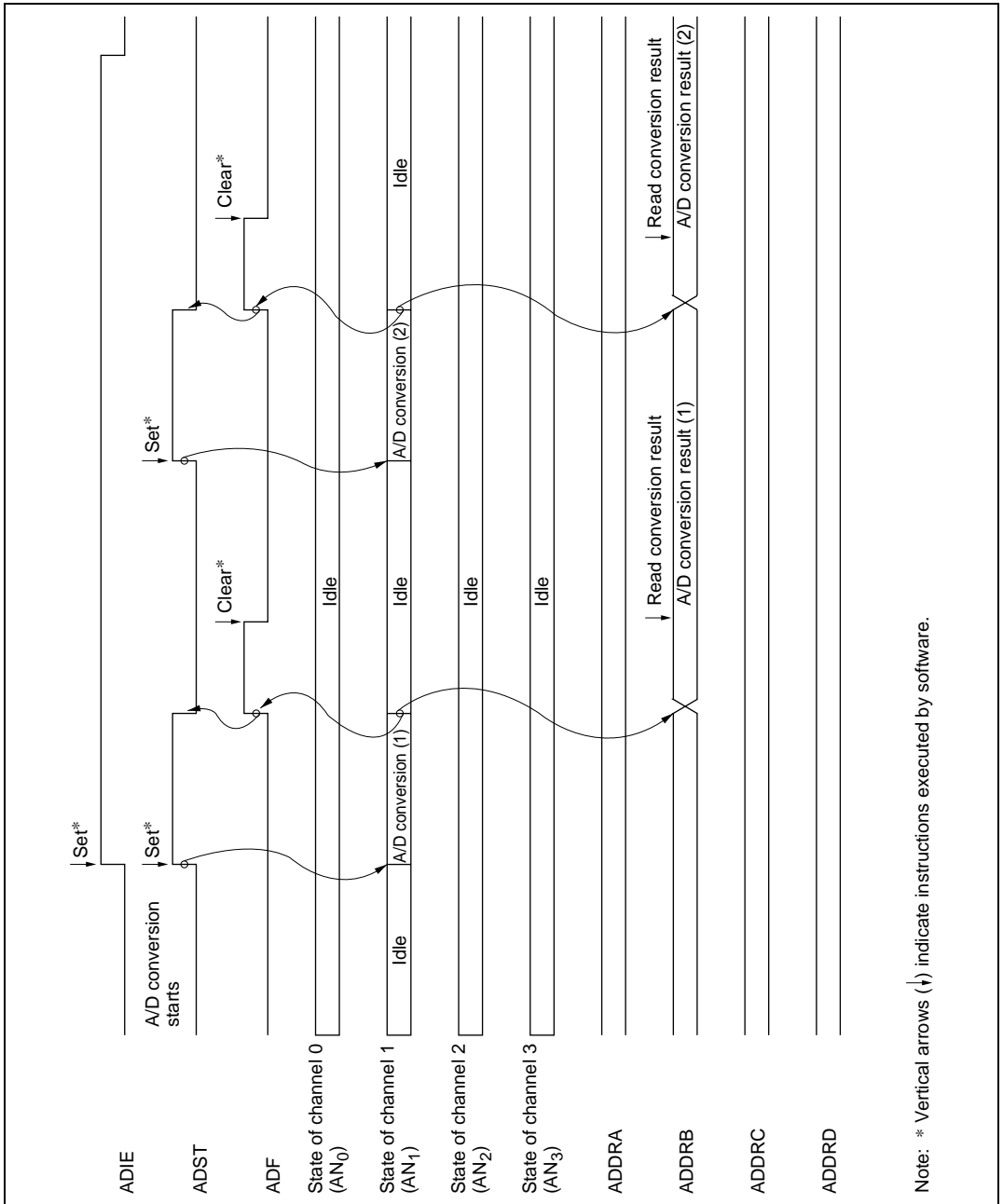

Figure 15.3 Example of A/D Converter Operation (Single Mode, Channel 1 Selected)

15.4.2 Scan Mode (SCAN = 1)

Scan mode is useful for monitoring analog inputs in a group of one or more channels. When the ADST bit is set to 1 by software or external trigger input, A/D conversion starts on the first channel in the group (AN_0 when $CH2 = 0$, AN_4 when $CH2 = 1$). When two or more channels are selected, after conversion of the first channel ends, conversion of the second channel (AN_1 or AN_5) starts immediately. A/D conversion continues cyclically on the selected channels until the ADST bit is cleared to 0. The conversion results are transferred for storage into the A/D data registers corresponding to the channels.

When the mode or analog input channel selection must be changed during analog conversion, to prevent incorrect operation, first clear the ADST bit to 0 in ADCSR to halt A/D conversion. After making the necessary changes, set the ADST bit to 1. A/D conversion will start again from the first channel in the group. The ADST bit can be set at the same time as the mode or channel selection is changed.

Typical operations when three channels in group 0 (AN_0 to AN_2) are selected in scan mode are described next. Figure 15.4 shows a timing diagram for this example.

1. Scan mode is selected ($SCAN = 1$), scan group 0 is selected ($CH2 = 0$), analog input channels AN_0 to AN_2 are selected ($CH1 = 1$, $CH0 = 0$), and A/D conversion is started ($ADST = 1$).
2. When A/D conversion of the first channel (AN_0) is completed, the result is transferred into ADDRA. Next, conversion of the second channel (AN_1) starts automatically.
3. Conversion proceeds in the same way through the third channel (AN_2).
4. When conversion of all selected channels (AN_0 to AN_2) is completed, the ADF flag is set to 1 and conversion of the first channel (AN_0) starts again. If the ADIE bit is set to 1, an ADI interrupt is requested at this time.
5. Steps 2 to 4 are repeated as long as the ADST bit remains set to 1. When the ADST bit is cleared to 0, A/D conversion stops. After that, if the ADST bit is set to 1, A/D conversion starts again from the first channel (AN_0).

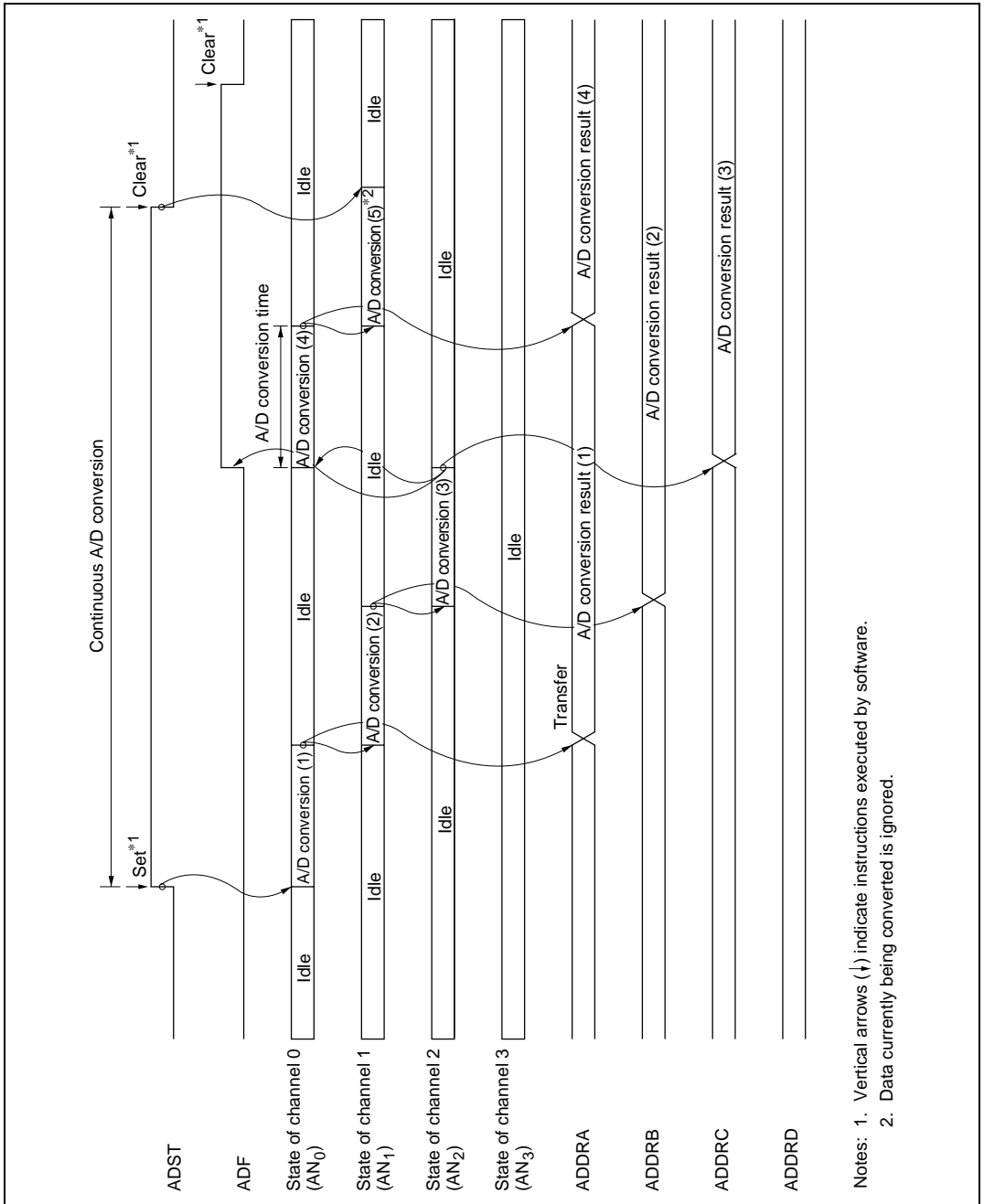

Figure 15.4 Example of A/D Converter Operation (Scan Mode, Channels AN₀ to AN₂ Selected)

15.4.3 Input Sampling and A/D Conversion Time

The A/D converter has a built-in sample-and-hold circuit. The A/D converter samples the analog input at a time t_D after the ADST bit is set to 1, then starts conversion. Figure 15.5 shows the A/D conversion timing. Table 15.4 indicates the A/D conversion time.

As indicated in figure 15.5, the A/D conversion time includes t_D and the input sampling time. The length of t_D varies depending on the timing of the write access to ADCSR. The total conversion time therefore varies within the ranges indicated in table 15.4.

In scan mode, the values given in table 15.4 apply to the first conversion. In the second and subsequent conversions the conversion time is fixed at 128 states when $CKS = 0$ or 66 states when $CKS = 1$.

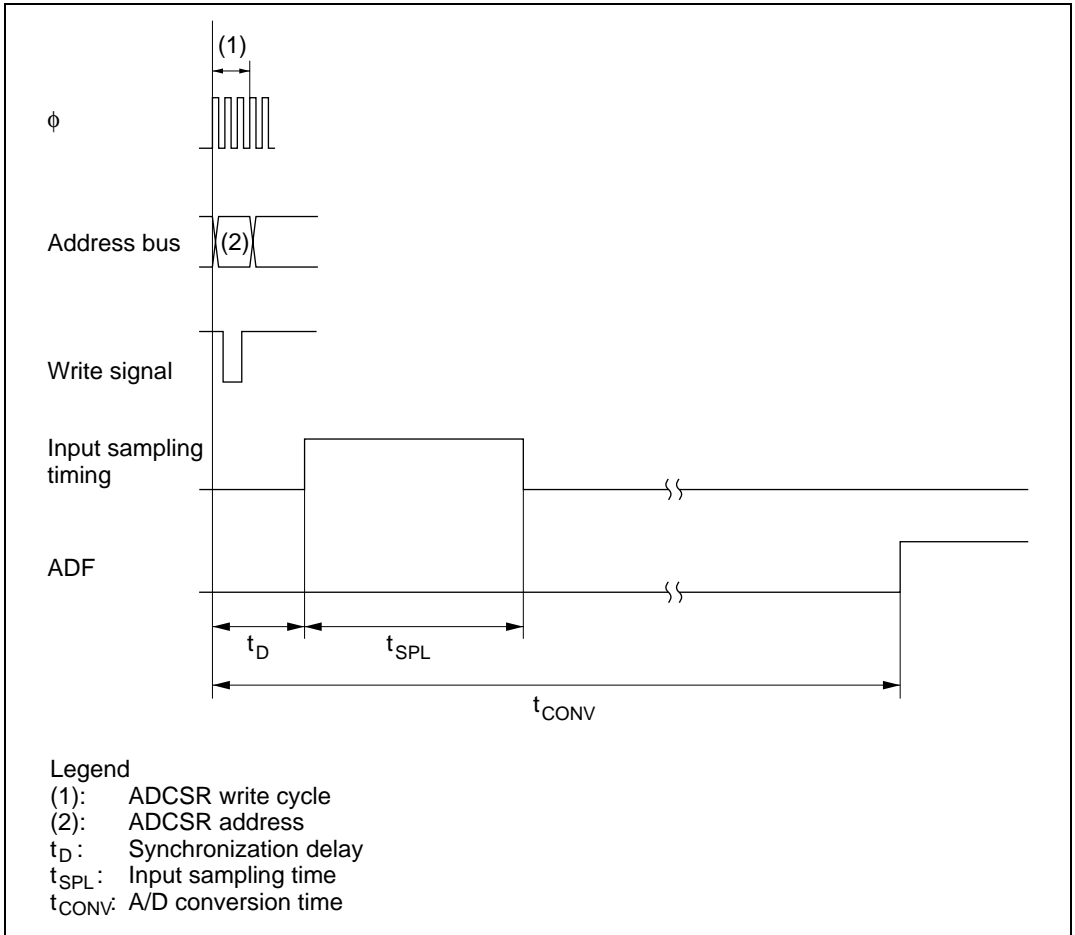

Figure 15.5 A/D Conversion Timing

Table 15.4 A/D Conversion Time (Single Mode)

Symbol	CKS = 0			CKS = 1			
	Min	Typ	Max	Min	Typ	Max	
Synchronization delay	t_D	6	—	9	4	—	5
Input sampling time	t_{SPL}	—	31	—	—	15	—
A/D conversion time	t_{CONV}	131	—	134	69	—	70

Note: Values in the table are numbers of states.

15.4.4 External Trigger Input Timing

A/D conversion can be externally triggered. When the TRGE bit is set to 1 in ADCR and the 8-bit timer's ADTE bit is cleared to 0, external trigger input is enabled at the $\overline{\text{ADTRG}}$ pin. A high-to-low transition at the $\overline{\text{ADTRG}}$ pin sets the ADST bit to 1 in ADCSR, starting A/D conversion. Other operations, in both single and scan modes, are the same as if the ADST bit had been set to 1 by software. Figure 15.6 shows the timing.

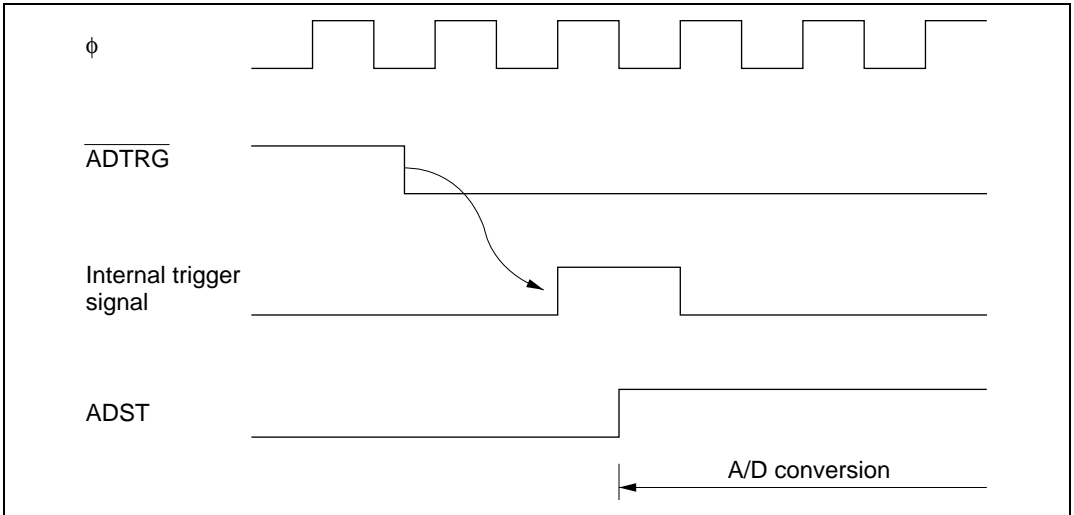

Figure 15.6 External Trigger Input Timing

15.5 Interrupts

The A/D converter generates an interrupt (ADI) at the end of A/D conversion. The ADI interrupt request can be enabled or disabled by the ADIE bit in ADCSR. The ADI interrupt request can be designated as a DMAC activation source. In this case, an interrupt request is not sent to the CPU.

15.6 Usage Notes

When using the A/D converter, note the following points:

1. **Analog Input Voltage Range:** During A/D conversion, the voltages input to the analog input pins should be in the range $AV_{SS} \leq AN_n \leq V_{REF}$.
2. **Relationships of AV_{CC} and AV_{SS} to V_{CC} and V_{SS} :** AV_{CC} , AV_{SS} , V_{CC} , and V_{SS} should be related as follows: $AV_{SS} = V_{SS}$. AV_{CC} and AV_{SS} must not be left open, even if the A/D converter is not used.
3. **V_{REF} Programming Range:** The reference voltage input at the V_{REF} pin should be in the range $V_{REF} \leq AV_{CC}$.
4. **Note on Board Design:** In board layout, separate the digital circuits from the analog circuits as much as possible. Particularly avoid layouts in which the signal lines of digital circuits cross or closely approach the signal lines of analog circuits. Induction and other effects may cause the analog circuits to operate incorrectly, or may adversely affect the accuracy of A/D conversion.

The analog input signals (AN_0 to AN_7), analog reference voltage (V_{REF}), and analog supply voltage (AV_{CC}) must be separated from digital circuits by the analog ground (AV_{SS}). The analog ground (AV_{SS}) should be connected to a stable digital ground (V_{SS}) at one point on the board.

5. **Note on Noise:** To prevent damage from surges and other abnormal voltages at the analog input pins (AN_0 to AN_7) and analog reference voltage pin (V_{REF}), connect a protection circuit like the one in figure 15.7 between AV_{CC} and AV_{SS} . The bypass capacitors connected to AV_{CC} and V_{REF} and the filter capacitors connected to AN_0 to AN_7 must be connected to AV_{SS} . If filter capacitors like the ones in figure 15.7 are connected, the voltage values input to the analog input pins (AN_0 to AN_7) will be smoothed, which may give rise to error. Error can also occur if A/D conversion is frequently performed in scan mode so that the current that charges and discharges the capacitor in the sample-and-hold circuit of the A/D converter becomes greater than that input to the analog input pins via input impedance R_{in} . The circuit constants should therefore be selected carefully.

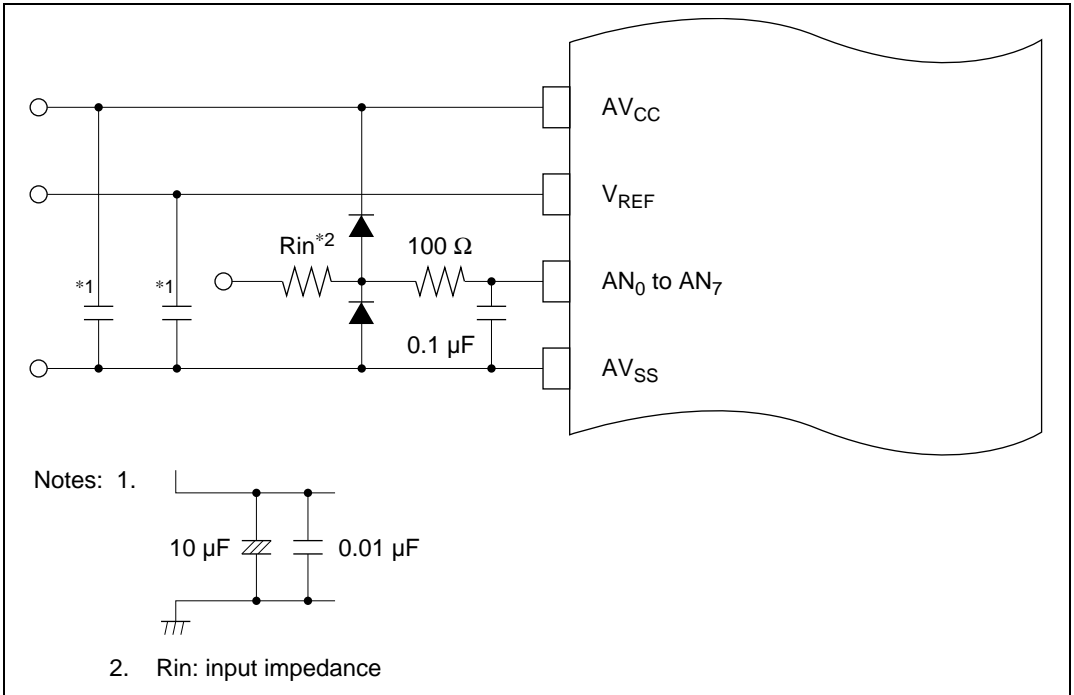

Figure 15.7 Example of Analog Input Protection Circuit

Table 15.5 Analog Input Pin Ratings

Item	min	max	Unit
Analog input capacitance	—	20	pF
Allowable signal-source impedance	—	10*	kΩ

Note: * When conversion time = 134 states, $V_{CC} = 4.0\text{ V to }5.5\text{ V}$, and $\phi \leq 13\text{ Mhz}$. For details see section 21, Electrical Characteristics.

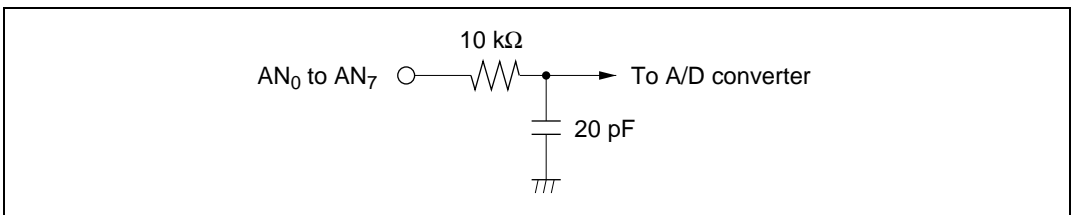

Figure 15.8 Analog Input Pin Equivalent Circuit

Note: Numeric values are approximate, except in table 15.5

6. A/D Conversion Accuracy Definitions: A/D conversion accuracy in the H8/3068F is defined as follows:

- Resolution: Digital output code length of A/D converter
- Offset error: Deviation from ideal A/D conversion characteristic of analog input voltage required to raise digital output from minimum voltage value 0000000000 to 0000000001 (figure 15.10)
- Full-scale error: Deviation from ideal A/D conversion characteristic of analog input voltage required to raise digital output from 1111111110 to 1111111111 (figure 15.10)
- Quantization error: Intrinsic error of the A/D converter; 1/2 LSB (figure 15.9)
- Nonlinearity error: Deviation from ideal A/D conversion characteristic in range from zero volts to full scale, exclusive of offset error, full-scale error, and quantization error.
- Absolute accuracy: Deviation of digital value from analog input value, including offset error, full-scale error, quantization error, and nonlinearity error.

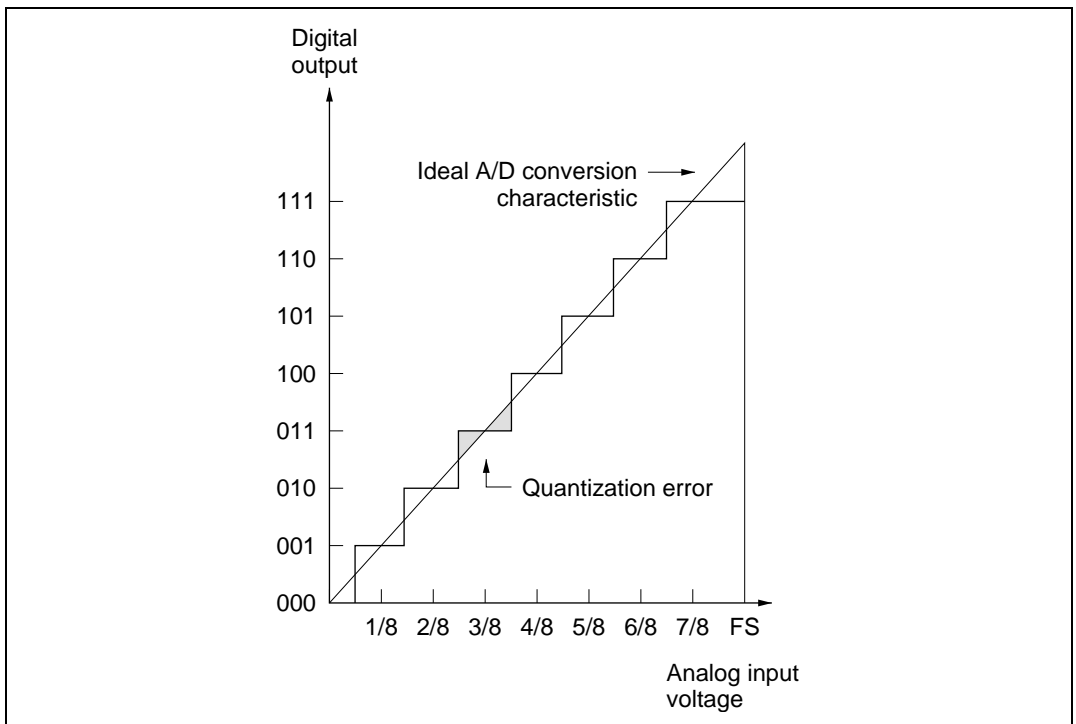

Figure 15.9 A/D Converter Accuracy Definitions (1)

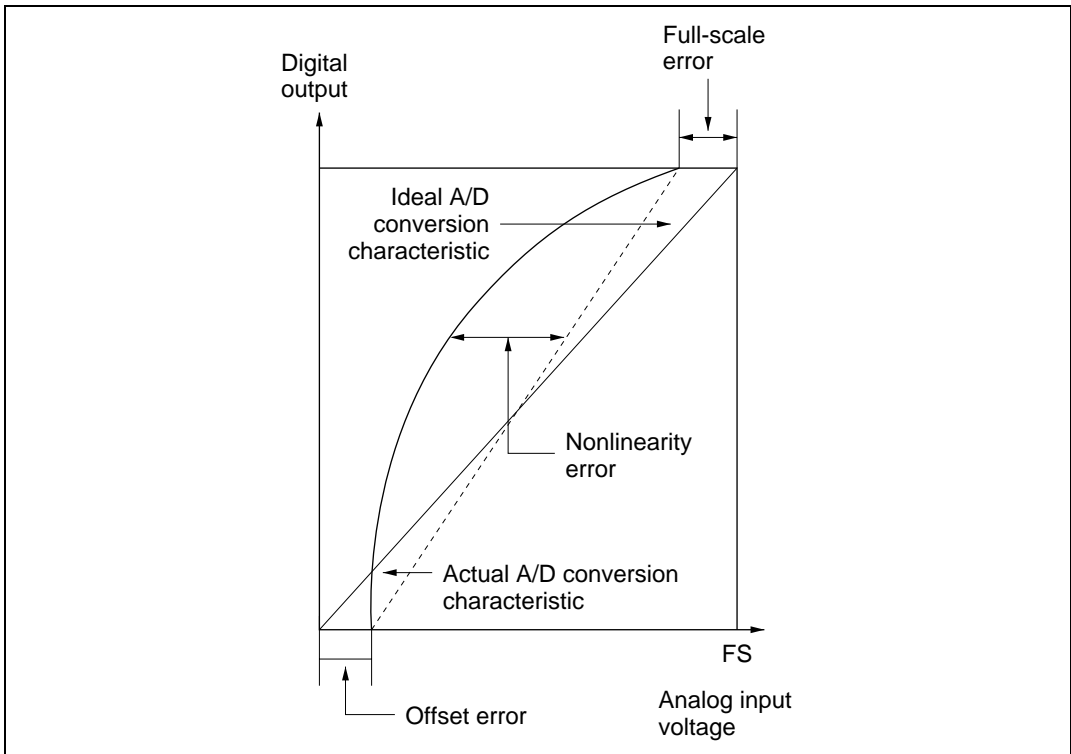

Figure 15.10 A/D Converter Accuracy Definitions (2)

7. **Allowable Signal-Source Impedance:** The analog inputs of the H8/3068F are designed to assure accurate conversion of input signals with a signal-source impedance not exceeding 10 k Ω . The reason for this rating is that it enables the input capacitor in the sample-and-hold circuit in the A/D converter to charge within the sampling time. If the sensor output impedance exceeds 10 k Ω , charging may be inadequate and the accuracy of A/D conversion cannot be guaranteed.

If a large external capacitor is provided in single mode, then the internal 10-k Ω input resistance becomes the only significant load on the input. In this case the impedance of the signal source is not a problem.

A large external capacitor, however, acts as a low-pass filter. This may make it impossible to track analog signals with high dv/dt (e.g. a variation of 5 mV/ μ s) (figure 15.11). To convert high-speed analog signals or to use scan mode, insert a low-impedance buffer.

8. **Effect on Absolute Accuracy:** Attaching an external capacitor creates a coupling with ground, so if there is noise on the ground line, it may degrade absolute accuracy. The capacitor must be connected to an electrically stable ground, such as AV_{SS}.

If a filter circuit is used, be careful of interference with digital signals on the same board, and make sure the circuit does not act as an antenna.

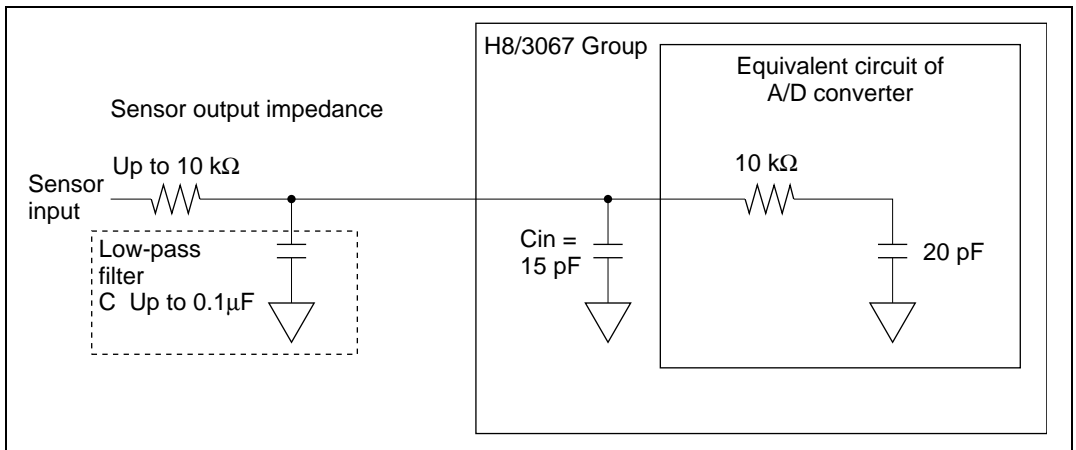

Figure 15.11 Analog Input Circuit (Example)

Section 16 D/A Converter

16.1 Overview

The H8/3068F includes a D/A converter with two channels.

16.1.1 Features

D/A converter features are listed below.

- Eight-bit resolution
- Two output channels
- Conversion time: maximum 10 μ s (with 20-pF capacitive load)
- Output voltage: 0 V to V_{REF}
- D/A outputs can be sustained in software standby mode

16.1.2 Block Diagram

Figure 16.1 shows a block diagram of the D/A converter.

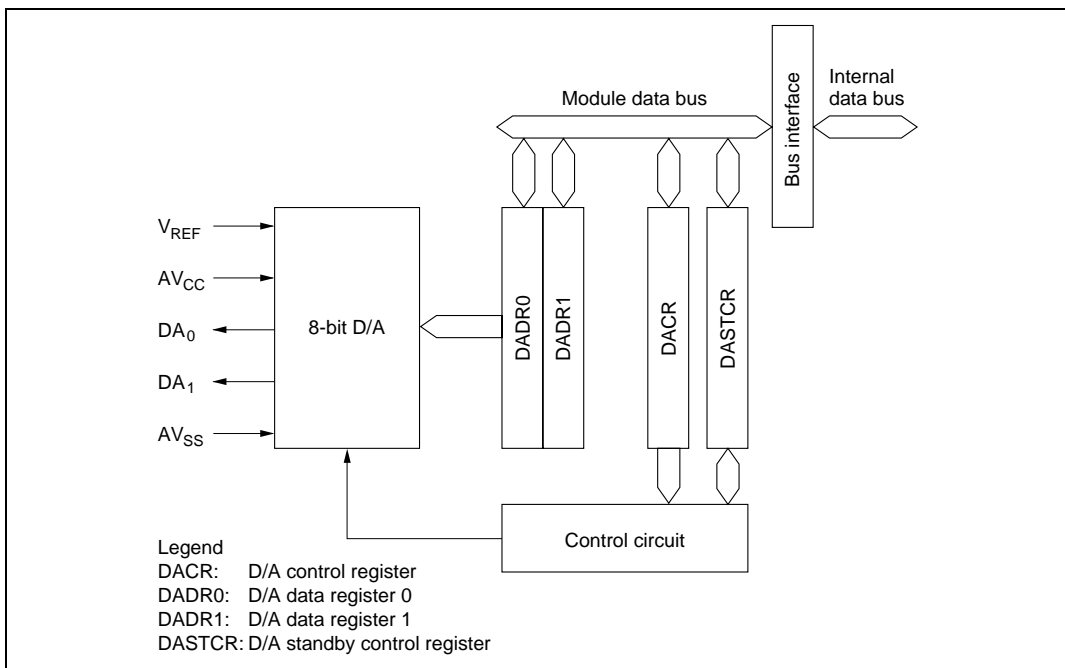

Figure 16.1 D/A Converter Block Diagram

16.1.3 Input/Output Pins

Table 16.1 summarizes the D/A converter's input and output pins.

Table 16.1 D/A Converter Pins

Pin Name	Abbreviation	I/O	Function
Analog power supply pin	AV _{CC}	Input	Analog power supply and reference voltage
Analog ground pin	AV _{SS}	Input	Analog ground and reference voltage
Analog output pin 0	DA ₀	Output	Analog output, channel 0
Analog output pin 1	DA ₁	Output	Analog output, channel 1
Reference voltage input pin	V _{REF}	Input	Analog reference voltage

16.1.4 Register Configuration

Table 16.2 summarizes the D/A converter's registers.

Table 16.2 D/A Converter Registers

Address*	Name	Abbreviation	R/W	Initial Value
H'FFF9C	D/A data register 0	DADR0	R/W	H'00
H'FFF9D	D/A data register 1	DADR1	R/W	H'00
H'FFF9E	D/A control register	DACR	R/W	H'1F
H'EE01A	D/A standby control register	DASTCR	R/W	H'FE

Note: * Lower 20 bits of the address in advanced mode.

16.2 Register Descriptions

16.2.1 D/A Data Registers 0 and 1 (DADR0/1)

Bit	7	6	5	4	3	2	1	0
Initial value	0	0	0	0	0	0	0	0
Read/Write	R/W	R/W	R/W	R/W	R/W	R/W	R/W	R/W

The D/A data registers (DADR0 and DADR1) are 8-bit readable/writable registers that store the data to be converted. When analog output is enabled, the D/A data register values are constantly converted and output at the analog output pins.

The D/A data registers are initialized to H'00 by a reset and in standby mode.

When the DASTE bit is set to 1 in the D/A standby control register (DASTCR), the D/A registers are not initialized in software standby mode.

16.2.2 D/A Control Register (DACR)

Bit	7	6	5	4	3	2	1	0
	DAOE1	DAOE0	DAE	—	—	—	—	—
Initial value	0	0	0	1	1	1	1	1
Read/Write	R/W	R/W	R/W	—	—	—	—	—

D/A enable
 Controls D/A conversion

D/A output enable 0
 Controls D/A conversion and analog output

D/A output enable 1
 Controls D/A conversion and analog output

DACR is an 8-bit readable/writable register that controls the operation of the D/A converter. DACR is initialized to H'1F by a reset and in standby mode.

When the DASTE bit is set to 1 in DASTCR, the DACR is not initialized in software standby mode.

Bit 7—D/A Output Enable 1 (DAOE1): Controls D/A conversion and analog output.

Bit 7**DAOE1 Description**

0	DA ₁ analog output is disabled
1	Channel-1 D/A conversion and DA ₁ analog output are enabled

Bit 6—D/A Output Enable 0 (DAOE0): Controls D/A conversion and analog output.

Bit 6**DAOE0 Description**

0	DA ₀ analog output is disabled
1	Channel-0 D/A conversion and DA ₀ analog output are enabled

Bit 5—D/A Enable (DAE): Controls D/A conversion, together with bits DAOE0 and DAOE1. When the DAE bit is cleared to 0, analog conversion is controlled independently in channels 0 and 1. When the DAE bit is set to 1, analog conversion is controlled together in channels 0 and 1. Output of the conversion results is always controlled independently by DAOE0 and DAOE1.

Bit 7 Bit 6 Bit 5**DAOE1 DAOE0 DAE Description**

0	0	—	D/A conversion is disabled in channels 0 and 1
	1	0	D/A conversion is enabled in channel 0 D/A conversion is disabled in channel 1
		1	D/A conversion is enabled in channels 0 and 1
1	0	0	D/A conversion is disabled in channel 0 D/A conversion is enabled in channel 1
		1	D/A conversion is enabled in channels 0 and 1
	1	—	D/A conversion is enabled in channels 0 and 1

When the DAE bit is set to 1, even if bits DAOE0 and DAOE1 in DACR and the ADST bit in ADCSR are cleared to 0, the same current is drawn from the analog power supply as during A/D and D/A conversion.

Bits 4 to 0—Reserved: These bits cannot be modified and are always read as 1.

16.2.3 D/A Standby Control Register (DASTCR)

DASTCR is an 8-bit readable/writable register that enables or disables D/A output in software standby mode.

Bit	7	6	5	4	3	2	1	0
	—	—	—	—	—	—	—	DASTE
Initial value	1	1	1	1	1	1	1	0
Read/Write	—	—	—	—	—	—	—	R/W

Reserved bits

D/A standby enable
Enables or disables D/A output in software standby mode

DASTCR is initialized to H'FE by a reset and in hardware standby mode. It is not initialized in software standby mode.

Bits 7 to 1—Reserved: These bits cannot be modified and are always read as 1.

Bit 0—D/A Standby Enable (DASTE): Enables or disables D/A output in software standby mode.

Bit 0

DASTE	Description
0	D/A output is disabled in software standby mode (Initial value)
1	D/A output is enabled in software standby mode

16.3 Operation

The D/A converter has two built-in D/A conversion circuits that can perform conversion independently.

D/A conversion is performed constantly while enabled in DACR. If the DADR0 or DADR1 value is modified, conversion of the new data begins immediately. The conversion results are output when bits DAOE0 and DAOE1 are set to 1.

An example of D/A conversion on channel 0 is given next. Timing is indicated in figure 16.2.

1. Data to be converted is written in DADR0.
2. Bit DAOE0 is set to 1 in DACR. D/A conversion starts and DA0 becomes an output pin. The converted result is output after the conversion time.

The output value is $\frac{\text{DADR contents}}{256} \times V_{\text{REF}}$

Output of this conversion result continues until the value in DADR0 is modified or the DAOE0 bit is cleared to 0.

3. If the DADR0 value is modified, conversion starts immediately, and the result is output after the conversion time.
4. When the DAOE0 bit is cleared to 0, DA0 becomes an input pin.

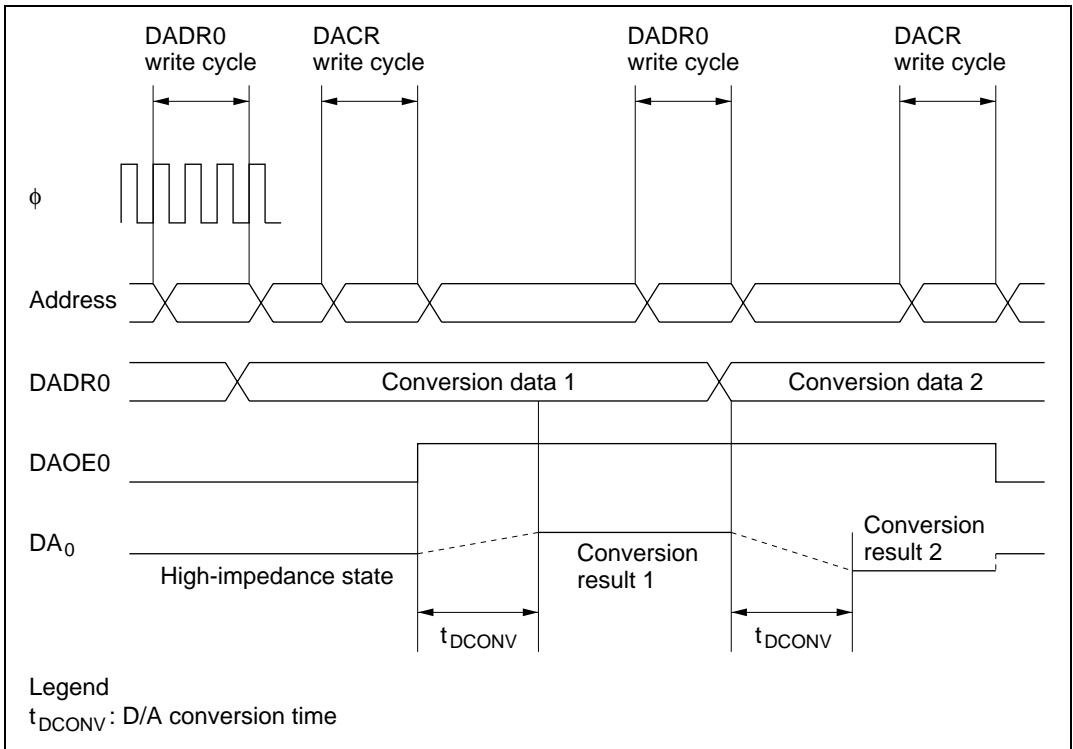

Figure 16.2 Example of D/A Converter Operation

16.4 D/A Output Control

In the H8/3068F, D/A converter output can be enabled or disabled in software standby mode.

When the DASTE bit is set to 1 in DASTCR, D/A converter output is enabled in software standby mode. The D/A converter registers retain the values they held prior to the transition to software standby mode.

When D/A output is enabled in software standby mode, the reference supply current is the same as during normal operation.

Section 17 RAM

17.1 Overview

The H8/3068F has 16 kbytes RAM. The RAM is connected to the CPU by a 16-bit data bus. The CPU accesses both byte data and word data in two states, making the RAM useful for rapid data transfer.

The on-chip RAM of the H8/3068F is assigned to addresses H'FBF20 to H'FFF1F in modes 1, 2, and 7, and to addresses H'FFBF20 to H'FFFF1F in modes 3, 4, and 5, and to addresses H'E720 to H'FF1F in mode 6. The RAM enable bit (RAME) in the system control register (SYSCR) can enable or disable the on-chip RAM.

17.1.1 Block Diagram

Figure 17.1 shows a block diagram of the on-chip RAM.

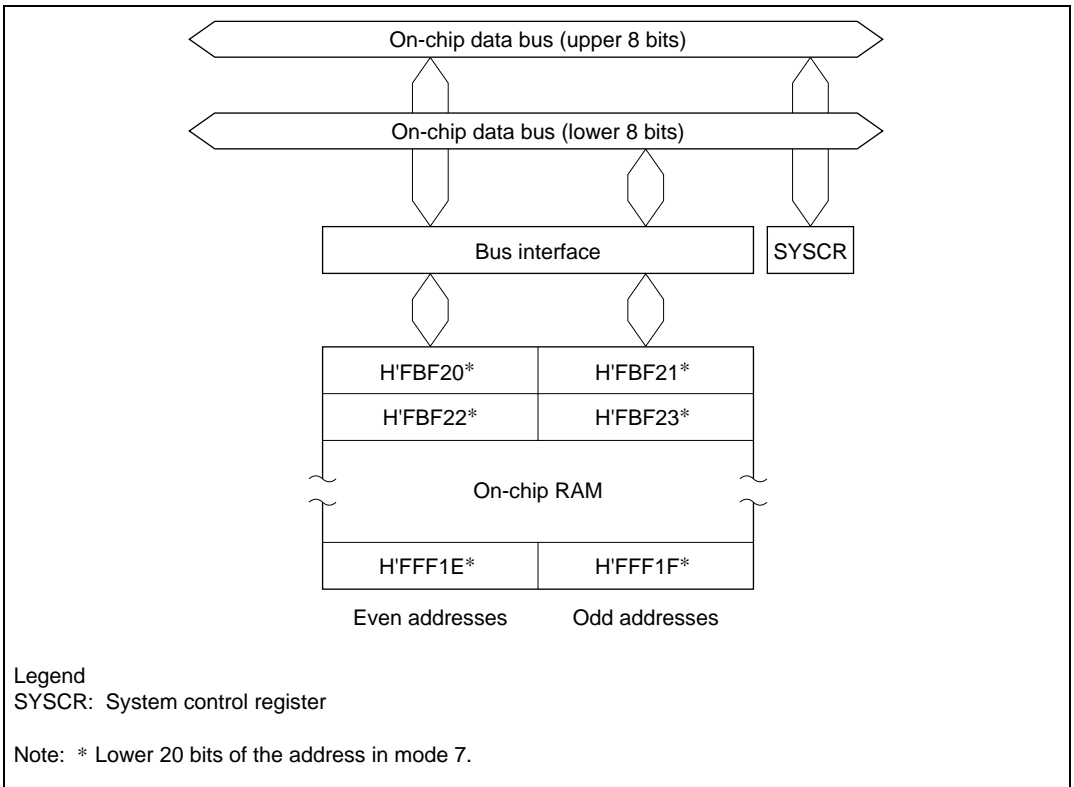

Figure 17.1 RAM Block Diagram

17.1.2 Register Configuration

The on-chip RAM is controlled by SYSCR. Table 17.1 gives the address and initial value of SYSCR.

Table 17.1 System Control Register

Address*	Name	Abbreviation	R/W	Initial Value
H'EE012	System control register	SYSCR	R/W	H'09

Note: * Lower 20 bits of the address in advanced mode.

17.2 System Control Register (SYSCR)

Bit	7	6	5	4	3	2	1	0
	SSBY	STS2	STS1	STS0	UE	NMIEG	SSOE	RAME
Initial value	0	0	0	0	1	0	0	1
Read/Write	R/W	R/W	R/W	R/W	R/W	R/W	R/W	R/W

RAM enable bit
 Enables or disables on-chip RAM

Software standby output port enable

NMI edge select

User bit enable

Standby timer select 2 to 0

Software standby

One function of SYSCR is to enable or disable access to the on-chip RAM. The on-chip RAM is enabled or disabled by the RAME bit in SYSCR. For details about the other bits, see section 3.3, System Control Register (SYSCR).

Bit 0—RAM Enable (RAME): Enables or disables the on-chip RAM. The RAME bit is initialized at the rising edge of the input at the $\overline{\text{RES}}$ pin. It is not initialized in software standby mode.

Bit 0 RAME	Description
0	On-chip RAM is disabled
1	On-chip RAM is enabled (Initial value)

17.3 Operation

When the RAME bit is set to 1, the on-chip RAM is enabled. Accesses to addresses H'FBF20 to H'FFF1F in modes 1, 2, and 7, and to addresses H'FFBF20 to H'FFFF1F in the H8/3068F in modes 3, 4, and 5, and to addresses H'7F20 to H'FF1F in mode 6, are directed to the on-chip RAM. In modes 1 to 5 (expanded modes), when the RAME bit is cleared to 0, the off-chip address space is accessed. In mode 6, 7 (single-chip mode), when the RAME bit is cleared to 0, the on-chip RAM is not accessed: read access always results in H'FF data, and write access is ignored.

Since the on-chip RAM is connected to the CPU by an internal 16-bit data bus, it can be written and read by word access. It can also be written and read by byte access. Byte data is accessed in two states using the upper 8 bits of the data bus. Word data starting at an even address is accessed in two states using all 16 bits of the data bus.

Section 18 Flash Memory

18.1 Overview

The H8/3068F-ZTAT has 384 kbytes of on-chip flash memory. The flash memory is connected to the CPU by a 16-bit data bus. The CPU accesses both byte data and word data in two states, enabling rapid data transfer.

The on-chip ROM is enabled and disabled by setting the mode pins (MD₂ to MD₀) as shown in table 18.1.

The on-chip flash memory product (H8/3068F-ZTAT) can be erased and programmed on-board, as well as with a special-purpose PROM programmer.

Table 18.1 Operating Modes and ROM

Mode	Mode Pins			On-Chip ROM
	MD2	MD1	MD0	
Mode 1 (expanded 1-Mbyte mode with on-chip ROM disabled)	0	0	1	Disabled (external address area)
Mode 2 (expanded 1-Mbyte mode with on-chip ROM disabled)	0	1	0	
Mode 3 (expanded 16-Mbyte mode with on-chip ROM disabled)	0	1	1	
Mode 4 (expanded 16-Mbyte mode with on-chip ROM disabled)	1	0	0	
Mode 5 (expanded 16-Mbyte mode with on-chip ROM enabled)	1	0	1	Enabled
Mode 6 (single-chip normal mode)	1	1	0	
Mode 7 (single-chip advanced mode)	1	1	1	

18.2 Features

The H8/3068F-ZTAT has 384 kbytes of on-chip flash memory.

The features of the flash memory are summarized below.

- Four flash memory operating modes

- Program mode
- Erase mode
- Program-verify mode
- Erase-verify mode

- Programming/erase methods

The flash memory is programmed 128 bytes at a time. Erasing is performed in block units. To erase the entire flash memory, each block must be erased in turn. In block erasing, 4-kbyte, 32-kbyte, and 64-kbyte blocks can be set arbitrarily.

- Programming/erase times

The flash memory programming time is 10 ms (typ.) for simultaneous 128-byte programming, equivalent approximately to 80 μ s (typ.) per byte, and the erase time is 100 ms (typ.) per block.

- Reprogramming capability

The flash memory can be reprogrammed up to 100 times.

- On-board programming modes

There are two modes in which flash memory can be programmed/erased/verified on-board:

- Boot mode
- User program mode

- Automatic bit rate adjustment

For data transfer in boot mode, the H8/3068F-ZTAT chip's bit rate can be automatically adjusted to match the transfer bit rate of the host.

- Flash memory emulation in RAM

Flash memory programming can be emulated in real time by overlapping a part of RAM onto flash memory.

- Protect modes

There are three protect modes—hardware, software, and error—which allow protected status to be designated for flash memory program/erase/verify operations

- PROM mode

Flash memory can be programmed/erased in PROM mode, using a PROM programmer, as well as in on-board programming mode.

18.2.1 Block Diagram

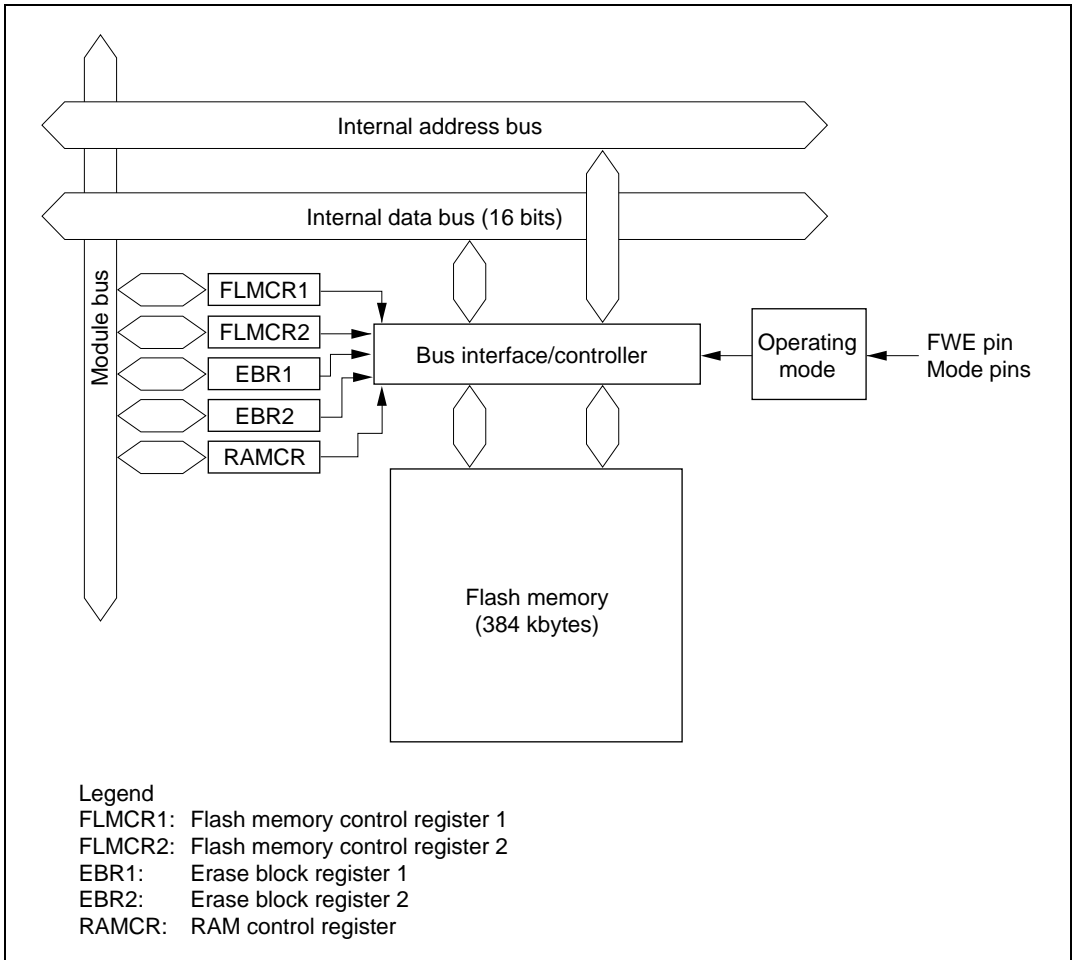

Figure 18.1 Block Diagram of Flash Memory

18.2.2 Pin Configuration

The flash memory is controlled by means of the pins shown in table 18.2.

Table 18.2 Flash Memory Pins

Pin Name	Abbreviation	I/O	Function
Reset	$\overline{\text{RES}}$	Input	Reset
Flash write enable	FWE	Input	Flash program/erase protection by hardware
Mode 2	MD ₂	Input	Sets H8/3068F-ZTAT operating mode
Mode 1	MD ₁	Input	Sets H8/3068F-ZTAT operating mode
Mode 0	MD ₀	Input	Sets H8/3068F-ZTAT operating mode
Transmit data	TxD ₁	Output	Serial transmit data output
Receive data	RxD ₁	Input	Serial receive data input

18.2.3 Register Configuration

The registers used to control the on-chip flash memory when enabled are shown in table 18.3.

Table 18.3 Flash Memory Registers

Register Name	Abbreviation	R/W	Initial Value	Address* ¹
Flash memory control register 1	FLMCR1	R/W	H'00* ²	H'EE030
Flash memory control register 2	FLMCR2	R	H'00	H'EE031
Erase block register 1	EBR1	R/W	H'00	H'EE032
Erase block register 2	EBR2	R/W	H'00	H'EE033
RAM control register	RAMCR	R/W	H'F0	H'EE077

Notes: FLMCR1, FLMCR2, EBR1, EBR2, and RAMCR are 8-bit registers, and should be accessed by byte access.

1. Lower 20 bits of address in advanced mode.
2. When a high level is input to the FWE pin, the initial value is H'80.

18.3 Register Descriptions

18.3.1 Flash Memory Control Register 1 (FLMCR1)

Bit	7	6	5	4	3	2	1	0
	FWE	SWE	ESU	PSU	EV	PV	E	P
Initial value	—*	0	0	0	0	0	0	0
Read/Write	R	R/W	R/W	R/W	R/W	R/W	R/W	R/W

Note: * Determined by the state of the FWE pin.

FLMCR1 is an 8-bit register used for flash memory operating mode control.

Program-verify mode or erase-verify mode for addresses H'00000 to H'5FFFF is entered by setting the SWE bit when FWE = 1, then setting the PV or EV bit. Program mode for addresses H'00000 to H'5FFFF is entered by setting the SWE bit when FWE = 1, then setting the PSU bit, and finally setting the P bit. Erase mode for addresses H'00000 to H'5FFFF is entered by setting the SWE bit when FWE = 1, then setting the ESU bit, and finally setting the E bit. FLMCR1 is initialized by a reset, and in hardware standby mode and software standby mode. Its initial value is H'80 when a high level is input to the FWE pin, and H'00 when a low level is input. In mode 6 the FWE pin must be fixed low since flash memory on-board programming modes are not supported. When the on-chip flash memory is disabled, a read access to this register will return H'00, and writes are invalid.

When setting bits 6 to 0 in this register, one bit must be set one at a time. Writes to the SWE bit in FLMCR1 are enabled only when FWE = 1; writes to bits ESU, PSU, EV, and PV only when FWE = 1 and SWE = 1; writes to the E bit only when FWE = 1, SWE = 1, and ESU = 1; and writes to the P bit only when FWE = 1, SWE = 1, and PSU = 1.

- Notes:
1. The programming and erase flowcharts must be followed when setting the bits in this register to prevent erroneous programming or erasing.
 2. Transitions are made to program mode, erase mode, program-verify mode, and erase-verify mode according to the settings in this register. When reading flash memory as normal on-chip ROM, bits 6 to 0 in this register must be cleared.

Bit 7—Flash Write Enable (FWE): Sets hardware protection against flash memory programming/erasing.

Bit 7**FWE** **Description**

0	When a low level is input to the FWE pin (hardware-protected state)
1	When a high level is input to the FWE pin

Bit 6—Software Write Enable (SWE): Enables or disables flash memory programming and erasing. (This bit should be set when setting bits 5 to 0, EBR1 bits 7 to 0, and EBR2 bits 3 to 0.)

Bit 6**SWE** **Description**

0	Programming/erasing disabled	(Initial value)
1	Programming/erasing enabled [Setting condition] When FWE = 1	

Note: Do not execute a SLEEP instruction while the SWE bit is set to 1.

Bit 5—Erase Setup (ESU): Prepares for a transition to erase mode. Set this bit to 1 before setting the E bit to 1 in FLMCR1 (do not set the SWE, PSU, EV, PV, E, or P bit at the same time).

Bit 5**ESU** **Description**

0	Erase setup cleared	(Initial value)
1	Erase setup [Setting condition] When FWE = 1 and SWE = 1	

Bit 4—Program Setup (PSU): Prepares for a transition to program mode. Set this bit to 1 before setting the P bit to 1 in FLMCR1 (do not set the SWE, ESU, EV, PV, E, or P bit at the same time).

Bit 4 PSU	Description
0	Program setup cleared (Initial value)
1	Program setup [Setting condition] When FWE = 1 and SWE = 1

Bit 3—Erase-Verify Mode (EV): Selects erase-verify mode transition or clearing. (Do not set the SWE, ESU, PSU, PV, E, or P bit at the same time.)

Bit 3 EV	Description
0	Erase-verify mode cleared (Initial value)
1	Transition to erase-verify mode [Setting condition] When FWE = 1 and SWE = 1

Bit 2—Program-Verify Mode (PV): Selects program-verify mode transition or clearing. (Do not set the SWE, ESU, PSU, EV, E, or P bit at the same time.)

Bit 2 PV	Description
0	Program-verify mode cleared (Initial value)
1	Transition to program-verify mode [Setting condition] When FWE = 1 and SWE = 1

Bit 1—Erase Mode (E): Selects erase mode transition or clearing. (Do not set the SWE, ESU, PSU, EV, PV, or P bit at the same time.)

Bit 1

E	Description	
0	Erase mode cleared	(Initial value)
1	Transition to erase mode [Setting condition] When FWE = 1, SWE = 1, and ESU = 1	

Note: Do not access the flash memory while the E bit is set.

Bit 0—Program (P): Selects program mode transition or clearing. (Do not set the SWE, ESU, PSU, EV, PV, or E bit at the same time.)

Bit 0

P	Description	
0	Program mode cleared	(Initial value)
1	Transition to program mode [Setting condition] When FWE = 1, SWE = 1, and PSU = 1	

Note: Do not access the flash memory while the P bit is set.

18.3.2 Flash Memory Control Register 2 (FLMCR2)

Bit	7	6	5	4	3	2	1	0
	FLER	—	—	—	—	—	—	—
Initial value	0	0	0	0	0	0	0	0
Read/Write	R	R	R	R	R	R	R	R

FLMCR2 is an 8-bit register used for flash memory operating mode control. FLMCR2 is initialized to H'00 by a reset, and in hardware standby mode and software standby mode. When the on-chip flash memory is disabled, a read will return H'00.

Note: FLMCR2 is a read-only register, and should not be written to.

Bit 7—Flash Memory Error (FLER): Indicates that an error has occurred during an operation on flash memory (programming or erasing). When FLER is set to 1, flash memory goes to the error-protection state.

Bit 7 FLER	Description
0	Flash memory is operating normally Flash memory program/erase protection (error protection) is disabled [Clearing condition] Reset ($\overline{\text{RES}}$ pin or WDT reset) or hardware standby mode (Initial value)
1	An error occurred during flash memory programming/erasing Flash memory program/erase protection (error protection) is enabled [Setting conditions] <ul style="list-style-type: none"> When flash memory is read during programming/erasing (including a vector read or instruction fetch, but excluding a read of the RAM area overlapping flash memory space) Immediately after the start of exception handling during programming/erasing (excluding reset, illegal instruction, trap instruction, and division-by-zero exception handling) When a SLEEP instruction (including software standby) is executed during programming/erasing When the bus is released during programming/erasing

Bits 6 to 0—Reserved: These bits are always read as 0.

18.3.3 Erase Block Register 1 (EBR1)

Bit	7	6	5	4	3	2	1	0
	EB7	EB6	EB5	EB4	EB3	EB2	EB1	EB0
Initial value	0	0	0	0	0	0	0	0
Read/Write	R/W	R/W	R/W	R/W	R/W	R/W	R/W	R/W

EBR1 is an 8-bit register that specifies the flash memory erase area block by block. EBR1 is initialized to H'00 by a reset, in hardware standby mode and software standby mode, when a low level is input to the FWE pin, and when a high level is input to the FWE pin and the SWE bit in FLMCR1 is not set. When a bit in EBR1 is set to 1, the corresponding block can be erased. Other blocks are erase-protected. Only one bit can be set in EBR1 and EBR2 together; do not set two or

more bits at the same time. When the on-chip flash memory is disabled, a read access to this register will return H'00, and erasing is disabled.

The flash memory block configuration is shown in table 18.4. To erase the entire flash memory, each block must be erased in turn.

As the H8/3068F-ZTAT does not support on-board programming modes in mode 6, EBR1 register bits cannot be set to 1 in this mode.

18.3.4 Erase Block Register 2 (EBR2)

Bit	7	6	5	4	3	2	1	0
	—	—	EB13	EB12	EB11	EB10	EB9	EB8
Initial value	0	0	0	0	0	0	0	0
Read/Write	R	R	R/W	R/W	R/W	R/W	R/W	R/W

EBR2 is an 8-bit register that specifies the flash memory erase area block by block. EBR2 is initialized to H'00 by a reset, in hardware standby mode and software standby mode, and when a low level is input to the FWE pin. When a high level is input to the FWE pin and the SWE bit in FLMCR1 is not set, it is initialized to bit 0. When a bit in EBR2 is set to 1, the corresponding block can be erased. Other blocks are erase-protected. Only one bit can be set in EBR1 and EBR2 together; do not set two or more bits at the same time. When the on-chip flash memory is disabled, a read will return H'00, and erasing is disabled.

The flash memory block configuration is shown in table 18.4. To erase the entire flash memory, each block must be erased in turn.

As the H8/3068F-ZTAT does not support on-board programming modes in mode 6, EBR2 register bits cannot be set to 1 in this mode.

Note: Bits 7 and 4 in this register are read-only. These bits must not be set to 1. If bits 7 and 4 are set when an EBR1/EBR2 bit is set, EBR1/EBR2 will be initialized to H'00.

Table 18.4 Flash Memory Erase Blocks

Block (Size)	Addresses
EB0 (4 kbytes)	H'000000 to H'000FFF
EB1 (4 kbytes)	H'001000 to H'001FFF
EB2 (4 kbytes)	H'002000 to H'002FFF
EB3 (4 kbytes)	H'003000 to H'003FFF
EB4 (4 kbytes)	H'004000 to H'004FFF
EB5 (4 kbytes)	H'005000 to H'005FFF
EB6 (4 kbytes)	H'006000 to H'006FFF
EB7 (4 kbytes)	H'007000 to H'007FFF
EB8 (32 kbytes)	H'008000 to H'00FFFF
EB9 (64 kbytes)	H'010000 to H'01FFFF
EB10 (64 kbytes)	H'020000 to H'02FFFF
EB11 (64 kbytes)	H'030000 to H'03FFFF
EB12 (64 kbytes)	H'040000 to H'04FFFF
EB13 (64 kbytes)	H'050000 to H'05FFFF

18.3.5 RAM Control Register (RAMCR)

Bit	7	6	5	4	3	2	1	0
	—	—	—	—	RAMS	RAM2	RAM1	RAM0
Initial value	1	1	1	1	0	0	0	0
Read/Write	R	R	R	R	R/W	R/W	R/W	R/W

RAMCR specifies the area of flash memory to be overlapped with part of RAM when emulating realtime flash memory programming. RAMCR is initialized to H'00 by a reset and in hardware standby mode. RAMCR settings should be made in user mode or user program mode.

Flash memory area divisions are shown in table 18.5. To ensure correct operation of the emulation function, the ROM for which RAM emulation is performed should not be accessed immediately after this register has been modified. Normal execution of an access immediately after register modification is not guaranteed.

Bits 7 to 4—Reserved: These bits cannot be modified and are always read as 1.

Bit 3—RAM Select (RAMS): Specifies selection or non-selection of flash memory emulation in RAM. When RAMS = 1, all flash memory blocks are program/erase-protected.

Bit 3 RAMS	Description
0	Emulation not selected Program/erase-protection of all flash memory blocks is disabled (Initial value)
1	Emulation selected Program/erase-protection of all flash memory blocks is enabled

Bits 2 to 0—Flash Memory Area Selection (RAM2 to RAM0): These bits are used together with bit 3 to select the flash memory area to be overlapped with RAM. (See table 18.5.)

Table 18.5 Flash Memory Area Divisions

RAM Area	Block Name	RAMS	RAM2	RAM1	RAM0
H'FFE000 to H'FFFEFF	4-kbyte RAM area	0	*	*	*
H'000000 to H'000FFF	EB0 (4 kbytes)	1	0	0	0
H'001000 to H'001FFF	EB1 (4 kbytes)	1	0	0	1
H'002000 to H'002FFF	EB2 (4 kbytes)	1	0	1	0
H'003000 to H'003FFF	EB3 (4 kbytes)	1	0	1	1
H'004000 to H'004FFF	EB4 (4 kbytes)	1	1	0	0
H'005000 to H'005FFF	EB5 (4 kbytes)	1	1	0	1
H'006000 to H'006FFF	EB6 (4 kbytes)	1	1	1	0
H'007000 to H'007FFF	EB7 (4 kbytes)	1	1	1	1

*: Don't care

Note: Flash memory emulation by RAM is not supported in mode 6 (single-chip normal mode); therefore, although these bits can be written, they should not be set to 1.

When performing flash memory emulation by RAM, the RAME bit in SYSCR must be set to 1.

18.4 Overview of Operation

18.4.1 Mode Transitions

When the mode pins and the FWE pin are set in the reset state and a reset-start is executed, the H8/3068F-ZTAT enters one of the operating modes shown in figure 18.2. In user mode, flash memory can be read but not programmed or erased.

Flash memory can be programmed and erased in boot mode, user program mode, and PROM mode.

Boot mode and user program mode cannot be used in the H8/3068F-ZTAT's mode 6 (normal mode with on-chip ROM enabled).

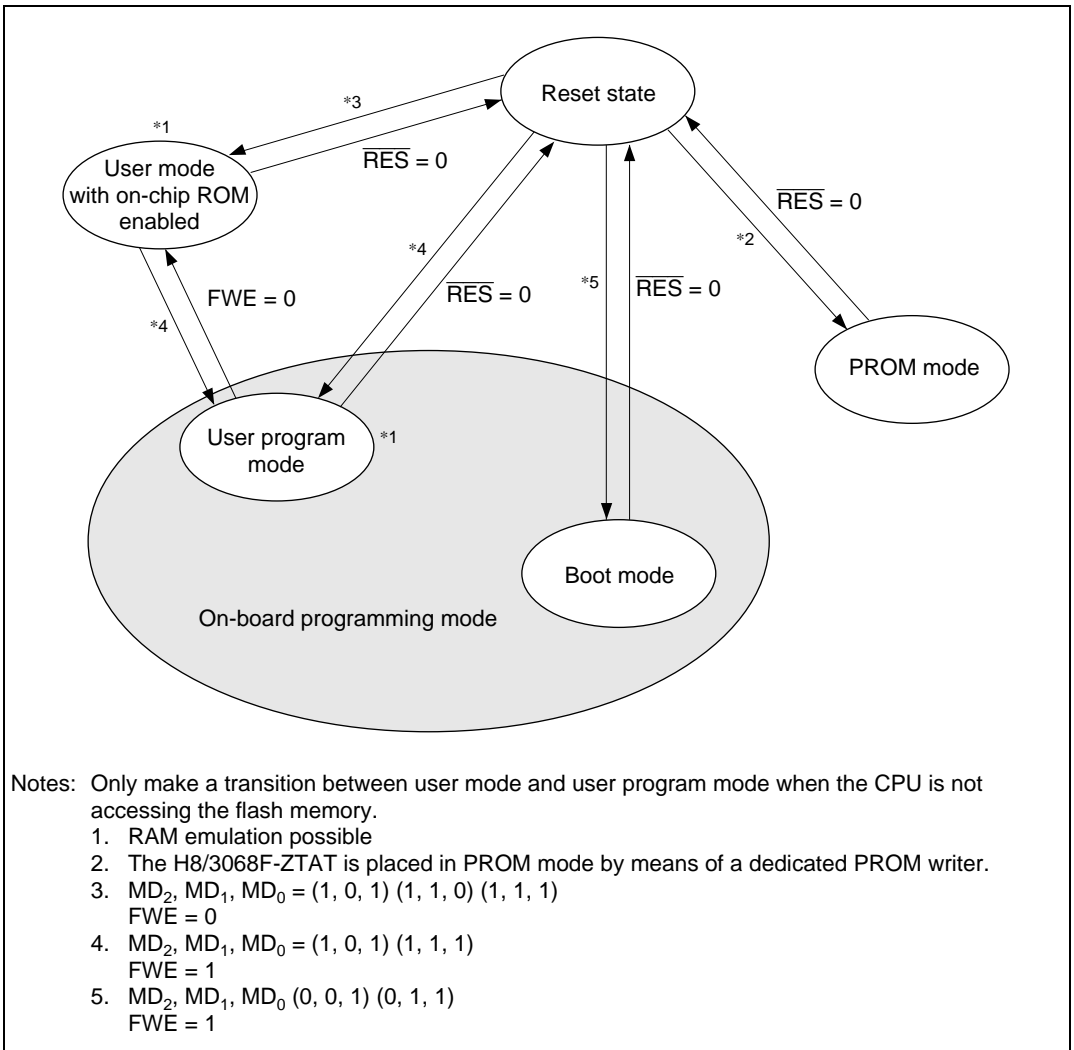

Figure 18.2 Flash Memory Related State Transitions

State transitions between the normal and user modes and on-board programming mode are performed by changing the FWE pin level from high to low or from low to high. To prevent misoperation (erroneous programming or erasing) in these cases, the bits in the flash memory control register (FLMCR1) should be cleared to 0 before making such a transition. After the bits are cleared, a wait time is necessary. Normal operation is not guaranteed if this wait time is insufficient.

18.4.2 On-Board Programming Modes

Example of Boot Mode Operation

1. Initial state

The old program version or data remains written in the flash memory. The user should prepare the programming control program and new application program beforehand in the host.

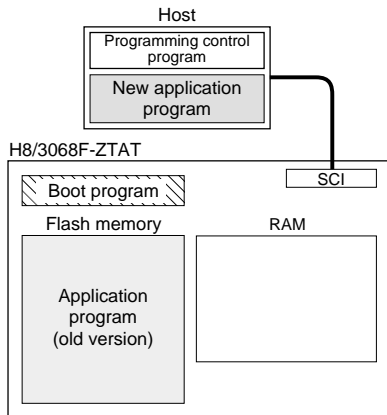

2. Programming control program transfer

When boot mode is entered, the boot program in the H8/3068F-ZTAT (originally incorporated in the chip) is started and the programming control program in the host is transferred to RAM via SCI communication. The boot program required for flash memory erasing is automatically transferred to the RAM boot program area.

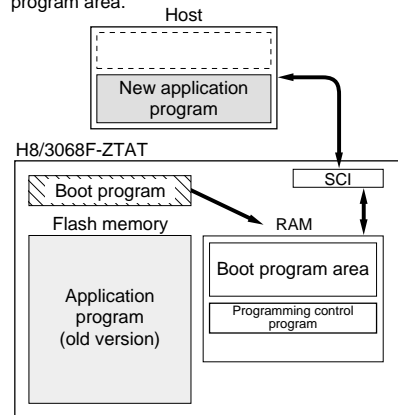

3. Flash memory initialization

The erase program in the boot program area (in RAM) is executed, and the flash memory is initialized (to H'FF). In boot mode, total flash memory erasure is performed, without regard to blocks.

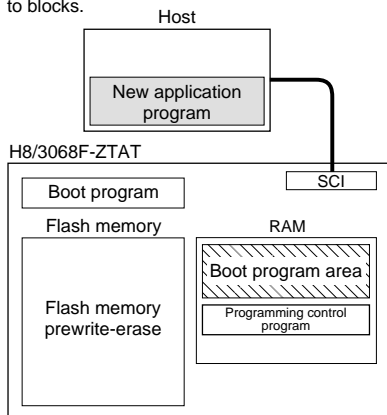

4. Writing new application program

The programming control program transferred from the host to RAM is executed, and the new application program in the host is written into the flash memory.

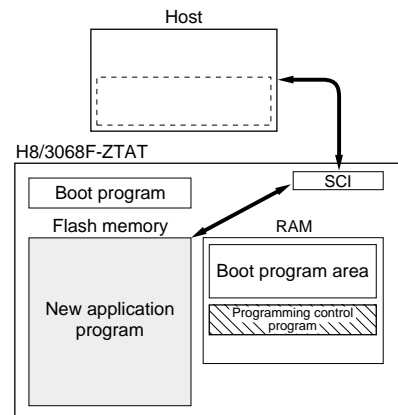

 Program execution state

Example of User Program Mode Operation

- 1. Initial state**
 The FWE assessment program that confirms that user program mode has been entered, and the program that will transfer the programming/erase control program from flash memory to on-chip RAM should be written into the flash memory by the user beforehand. The programming/erase control program should be prepared in the host or in the flash memory.

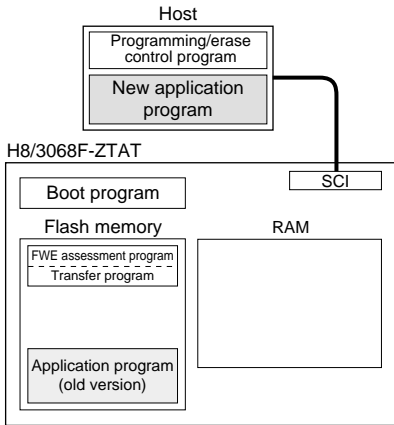

- 2. Programming/erase control program transfer**
 When user program mode is entered, user software recognizes this fact, executes the transfer program in the flash memory, and transfers the programming/erase control program to RAM.

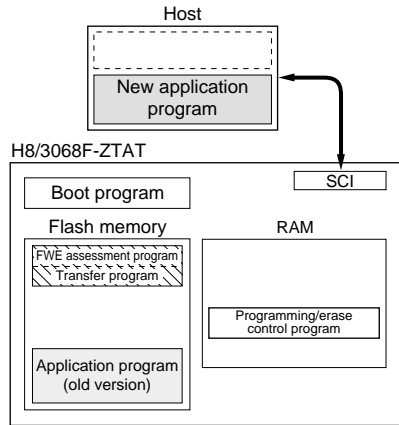

- 3. Flash memory initialization**
 The programming/erase program in RAM is executed, and the flash memory is initialized (to H'FF). Erasing can be performed in block units, but not in byte units.

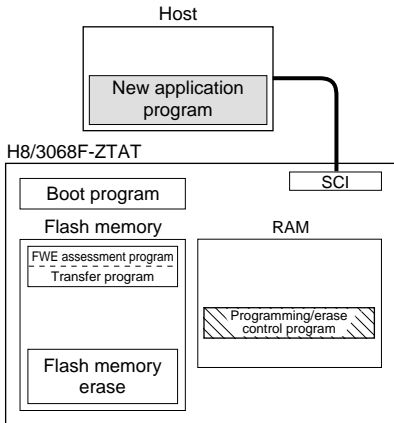

- 4. Writing new application program**
 Next, the new application program in the host is written into the erased flash memory blocks. Do not write to unerased blocks.

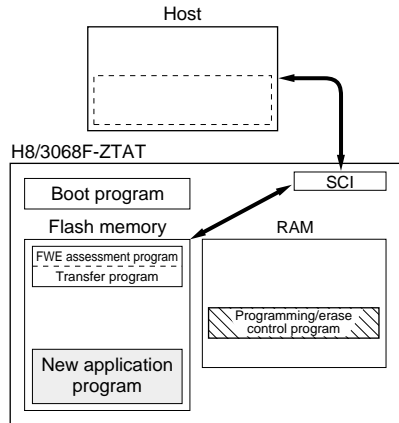

 Program execution state

18.4.3 Flash Memory Emulation in RAM

In the H8/3068F-ZTAT, flash memory programming can be emulated in real time by overlapping the flash memory with part of RAM (“overlap RAM”). When the emulation block set in RAMCR is accessed while the emulation function is being executed, data written in the overlap RAM is read.

Emulation should be performed in user mode or user program mode.

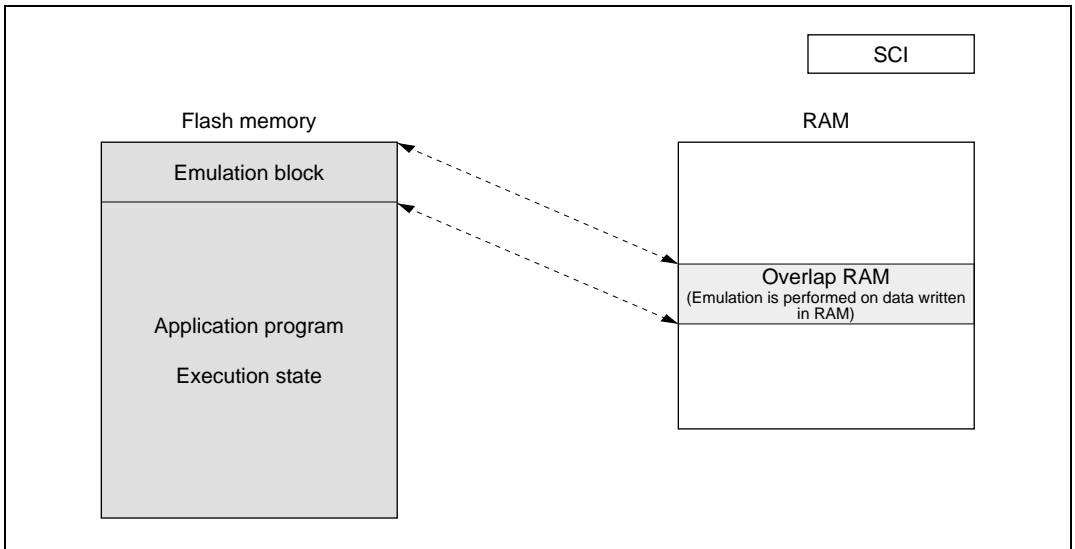

Figure 18.3 Reading Overlap RAM Data in User Mode/User Program Mode

When overlap RAM data is confirmed, clear the RAMS bit to cancel RAM overlap, and actually perform writes to the flash memory in user program mode.

When the programming control program is transferred to RAM in on-board programming mode, ensure that the transfer destination and the overlap RAM do not overlap, as this will cause data in the overlap RAM to be rewritten.

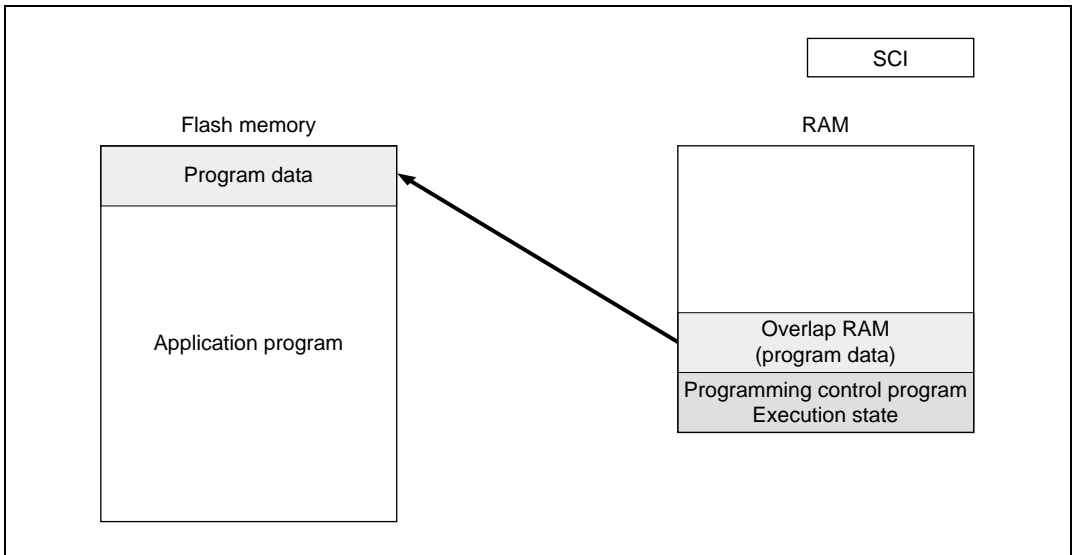
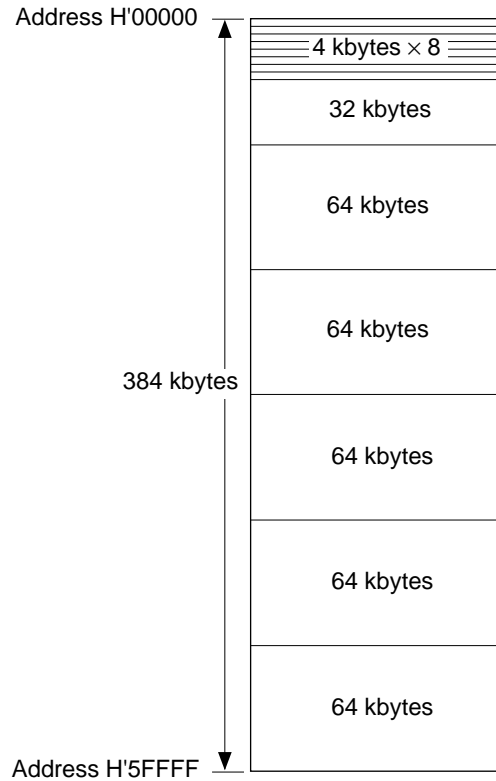

Figure 18.4 Writing Overlap RAM Data in User Program Mode

18.4.4 Block Configuration

The flash memory in the H8/3068F-ZTAT is divided into three 64-kbyte blocks, one 32-kbyte block, and eight 4-kbyte blocks. Erasing can be carried out in block units.



18.5 On-Board Programming Mode

When pins are set to on-board programming mode and a reset-start is executed, the chip enters the on-board programming state in which on-chip flash memory programming, erasing, and verifying can be carried out. There are two operating modes in this mode—boot mode and user program mode. The pin settings for entering each mode are shown in table 18.6. For a diagram of the transitions to the various flash memory modes, see figure 18.2.

Boot mode and user program mode cannot be used in the H8/3068F-ZTAT's mode 6 (on-chip ROM enabled).

Table 18.6 On-Board Programming Mode Settings

Mode		FWE	MD ₂	MD ₁	MD ₀
Boot mode	Mode 5	1* ¹	0* ²	0	1
	Mode 7		0* ²	1	1
User program mode	Mode 5		1	0	1
	Mode 7		1	1	1

Notes: 1. For the High level input timing, see items 6 and 7 of Notes on Using the Boot Mode.

2. In boot mode, the MD₂ setting should be the inverse of the input.

In the boot mode in the H8/3068F-ZTAT, the levels of the mode pins (MD₂ to MD₀) are reflected in mode select bits 2 to 0 (MDS2 to MDS0) in the mode control register (MDCR).

18.5.1 Boot Mode

When boot mode is used, a flash memory programming control program must be prepared beforehand in the host, and SCI channel 1, which is to be used, must be set to asynchronous mode.

When a reset-start is executed after setting the H8/3068F-ZTAT' pins to boot mode, the boot program already incorporated in the MCU is activated, and the programming control program prepared beforehand in the host is transmitted sequentially to the H8/3068F-ZTAT, using the SCI. In the H8/3068F-ZTAT, the programming control program received via the SCI is written into the programming control program area in on-chip RAM. After the transfer is completed, control branches to the start address (H'FFC720) of the programming control program area and the programming control program execution state is entered (flash memory programming/erasing can be performed).

Figure 18.5 shows a system configuration diagram when using boot mode, and figure 18.6 shows the boot program mode execution procedure.

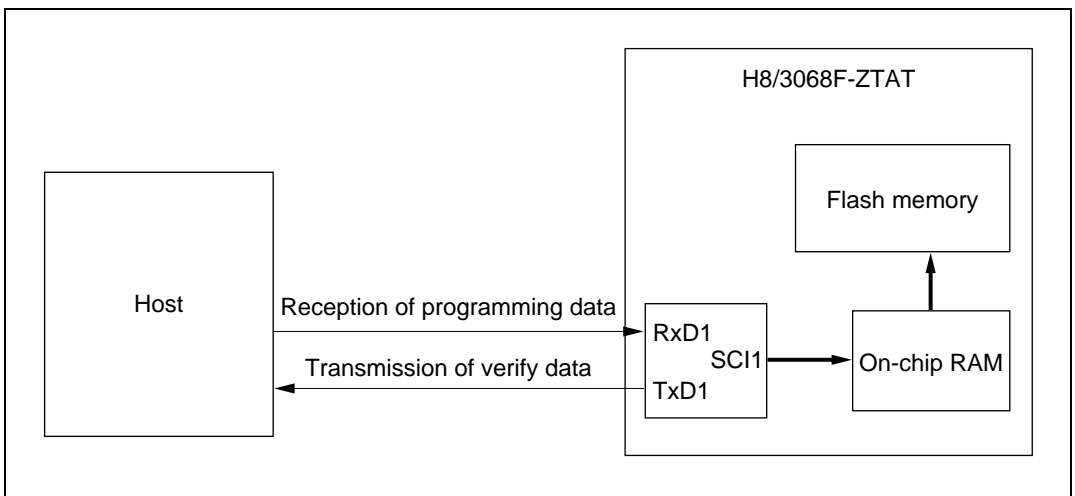

Figure 18.5 System Configuration When Using Boot Mode

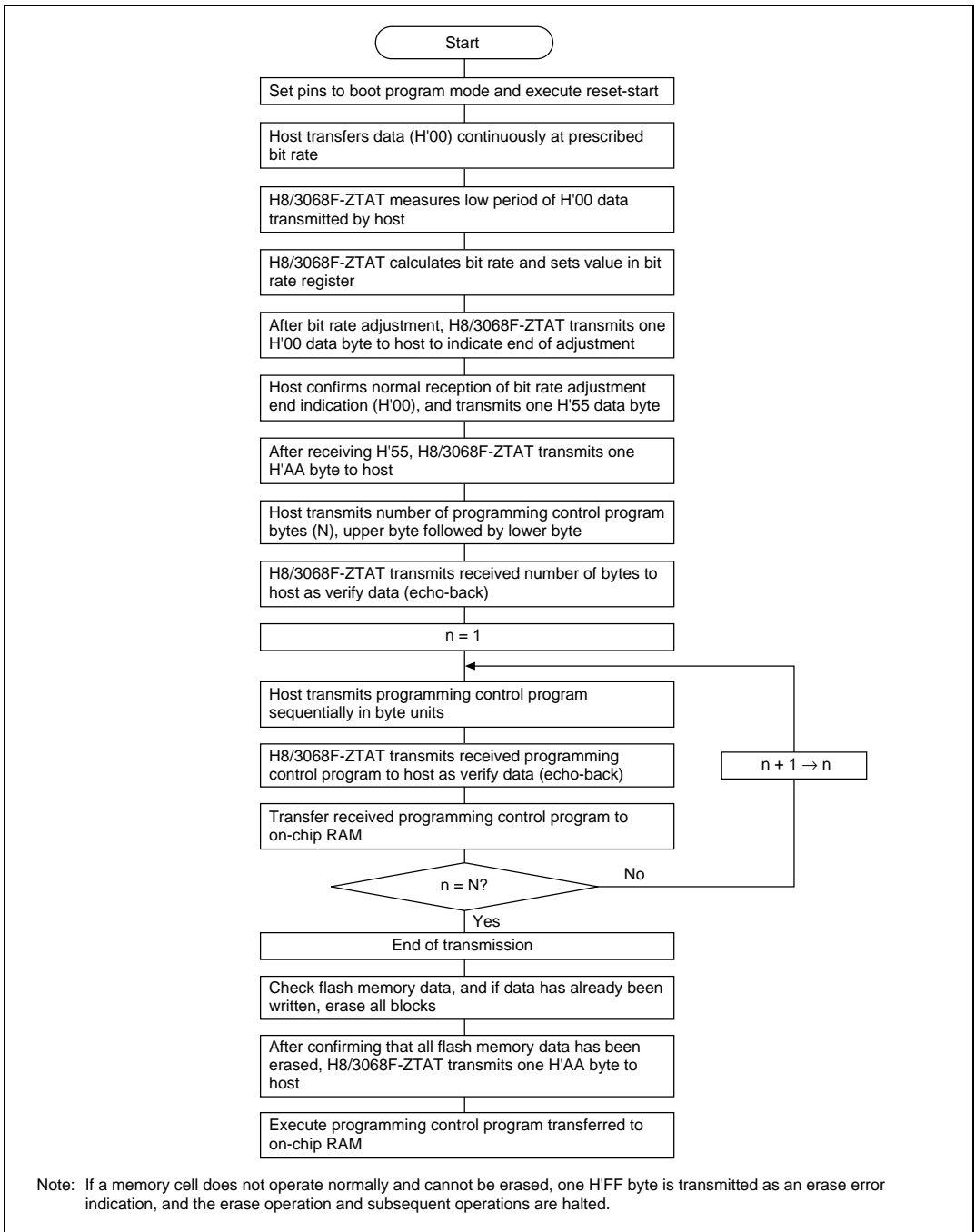
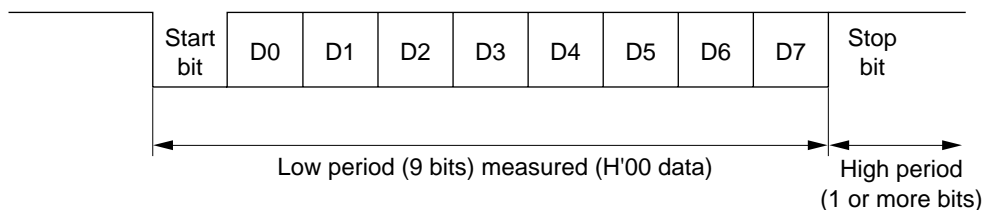

Figure 18.6 Boot Mode Execution Procedure

Automatic SCI Bit Rate Adjustment:

When boot mode is initiated, the H8/3068F-ZTAT measures the low period of the asynchronous SCI communication data (H'00) transmitted continuously from the host. The SCI transmit/receive format should be set as 8-bit data, 1 stop bit, no parity. The H8/3068F-ZTAT calculates the bit rate of the transmission from the host from the measured low period, and transmits one H'00 byte to the host to indicate the end of bit rate adjustment. The host should confirm that this adjustment end indication (H'00) has been received normally, and transmit one H'55 byte to the H8/3068F-ZTAT. If reception cannot be performed normally, initiate boot mode again (reset), and repeat the above operations. Depending on the host's transmission bit rate and the H8/3068F-ZTAT's system clock frequency, there will be a discrepancy between the bit rates of the host and the H8/3068F-ZTAT. To ensure correct SCI operation, the host's transfer bit rate should be set to 4800, 9600, or 19,200 bps*.

Table 18.7 shows typical host transfer bit rates and system clock frequencies for which automatic adjustment of the H8/3068F-ZTAT bit rate is possible. The boot program should be executed within this system clock range.

Table 18.7 System Clock Frequencies for which Automatic Adjustment of H8/3068F-ZTAT Bit Rate is Possible

Host Bit Rate (bps)	System Clock Frequency for which Automatic Adjustment of H8/3068F-ZTAT Bit Rate is Possible (MHz)
19,200	16 to 25
9,600	8 to 25
4,800	4 to 25

Note: * Only use a setting of 4800, 9600, or 19200 bps for the host's bit rate. No other settings can be used.

Although the H8/3068F-ZTAT may also perform automatic bit rate adjustment with bit rate and system clock combinations other than those shown in table 18.7, a degree of error will arise between the bit rates of the host and the H8/3068F-ZTAT, and subsequent transfer will not be performed normally. Therefore, only a combination of bit rate and

system clock frequency within one of the ranges shown in table 18.7 can be used for boot mode execution.

On-Chip RAM Area Divisions in Boot Mode: In boot mode, the RAM area is divided into an area used by the boot program and an area to which the user program is transferred via the SCI, as shown in figure 18.7. The boot program area becomes available when a transition is made to the execution state for the user program transferred to RAM.

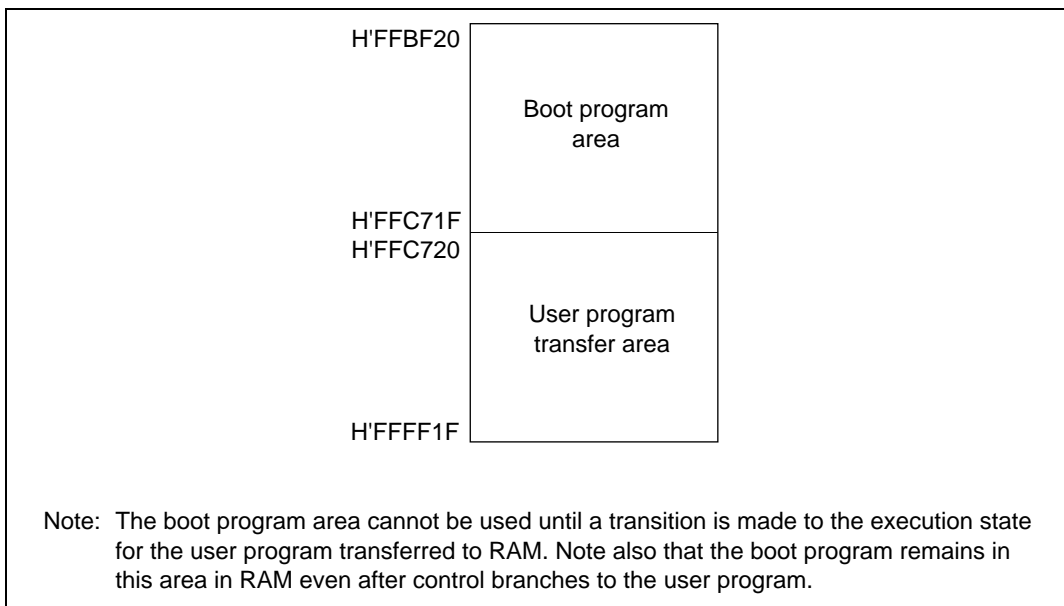

Figure 18.7 RAM Areas in Boot Mode

Notes on Use of Boot Mode:

1. When the H8/3068F-ZTAT chip comes out of reset in boot mode, it measures the low period of the input at the SCI's RxD₁ pin. The reset should end with RxD₁ high. After the reset ends, it takes about 100 states for the chip to get ready to measure the low period of the RxD₁ input.
2. In boot mode, if any data has been programmed into the flash memory (if all data is not 1), all flash memory blocks are erased. Boot mode is for use when user program mode is unavailable, such as the first time on-board programming is performed, or if the program activated in user program mode is accidentally erased.
3. Interrupts cannot be used while the flash memory is being programmed or erased.
4. The RxD₁ and TxD₁ lines should be pulled up on the board.
5. Before branching to the user program the H8/3068F-ZTAT terminates transmit and receive operations by the on-chip SCI (channel 1) (by clearing the RE and TE bits to 0 in the serial

control register (SCR)), but the adjusted bit rate value remains set in the bit rate register (BRR). The transmit data output pin, TxD₁, goes to the high-level output state (P9₁DDR = 1 in P9DDR, P9₁DR = 1 in P9DR).

The contents of the CPU's internal general registers are undefined at this time, so these registers must be initialized immediately after branching to the user program. In particular, since the stack pointer (SP) is used implicitly in subroutine calls, etc., a stack area must be specified for use by the user program.

The initial values of other on-chip registers are not changed.

6. Boot mode can be entered by setting pins MD₀ to MD₂ and FWE in accordance with the mode setting conditions shown in table 18.6, and then executing a reset-start.
 - a. When switching from boot mode to normal mode, the boot mode state within the chip must first be cleared by reset input via the $\overline{\text{RES}}$ pin*¹. The $\overline{\text{RES}}$ pin must be held low for at least 20 system clock cycles.*³
 - b. Do not change the input levels of the mode pins (MD₂ to MD₀) or the FWE pin in boot mode. To change the mode, the $\overline{\text{RES}}$ pin must first be driven low to set the reset state. Also, if a watchdog timer reset occurs in the boot mode state, the MCU's internal state will not be cleared, and the on-chip boot program will be restarted regardless of the mode pin states.
 - c. The FWE pin must not be driven low while the boot program is running or flash memory is being programmed or erased*².
7. If the mode pin input levels are changed (for example, from low to high) during a reset, the state of ports with multiplexed address functions and bus control output signals ($\overline{\text{CSn}}$, $\overline{\text{AS}}$, $\overline{\text{RD}}$, $\overline{\text{LWR}}$, $\overline{\text{HWR}}$) may also change according to the change in the MCU's operating mode. Therefore, care must be taken to make pin settings to prevent these pins from being used directly as output signal pins during a reset, or to prevent collision with signals outside the MCU.

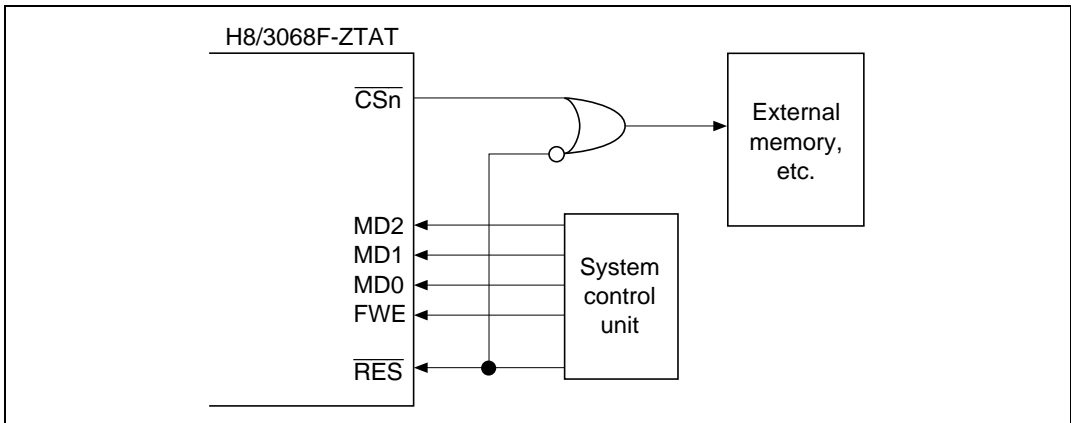

- Notes:
1. Mode pin and FWE pin input must satisfy the mode programming setup time (t_{MDS}) with respect to the reset release timing.
 2. For further information on FWE application and disconnection, see section 18.11, Flash Memory Programming and Erasing Precautions.
 3. See section 4.2.2, Reset Sequence, and section 18.11, Flash Memory Programming and Erasing Precautions. The H8/3068F-ZTAT requires a minimum of 20 system clock cycles for a reset during operation.

18.5.2 User Program Mode

When set to user program mode, the H8/3068F-ZTAT can program and erase its flash memory by executing a user program/erase control program. Therefore, on-board reprogramming of the on-chip flash memory can be carried out by providing on-board means of FWE control and supply of programming data, and storing a program/erase control program in part of the program area as necessary.

To select user program mode, select a mode that enables the on-chip ROM (mode 5 or 7), and apply a high level to the FWE pin. In this mode, on-chip supporting modules other than flash memory operate as they normally would in modes 5 and 7.

Flash memory programming/erasing should not be carried out in mode 6. When mode 6 is set, the FWE pin must be driven low.

The flash memory itself cannot be read while being programmed or erased, so the program that performs programming should be placed in external memory or transferred to RAM and executed there.

Figure 18.8 shows the execution procedure when user program mode is entered during program execution in RAM. It is also possible to start from user program mode in a reset-start.

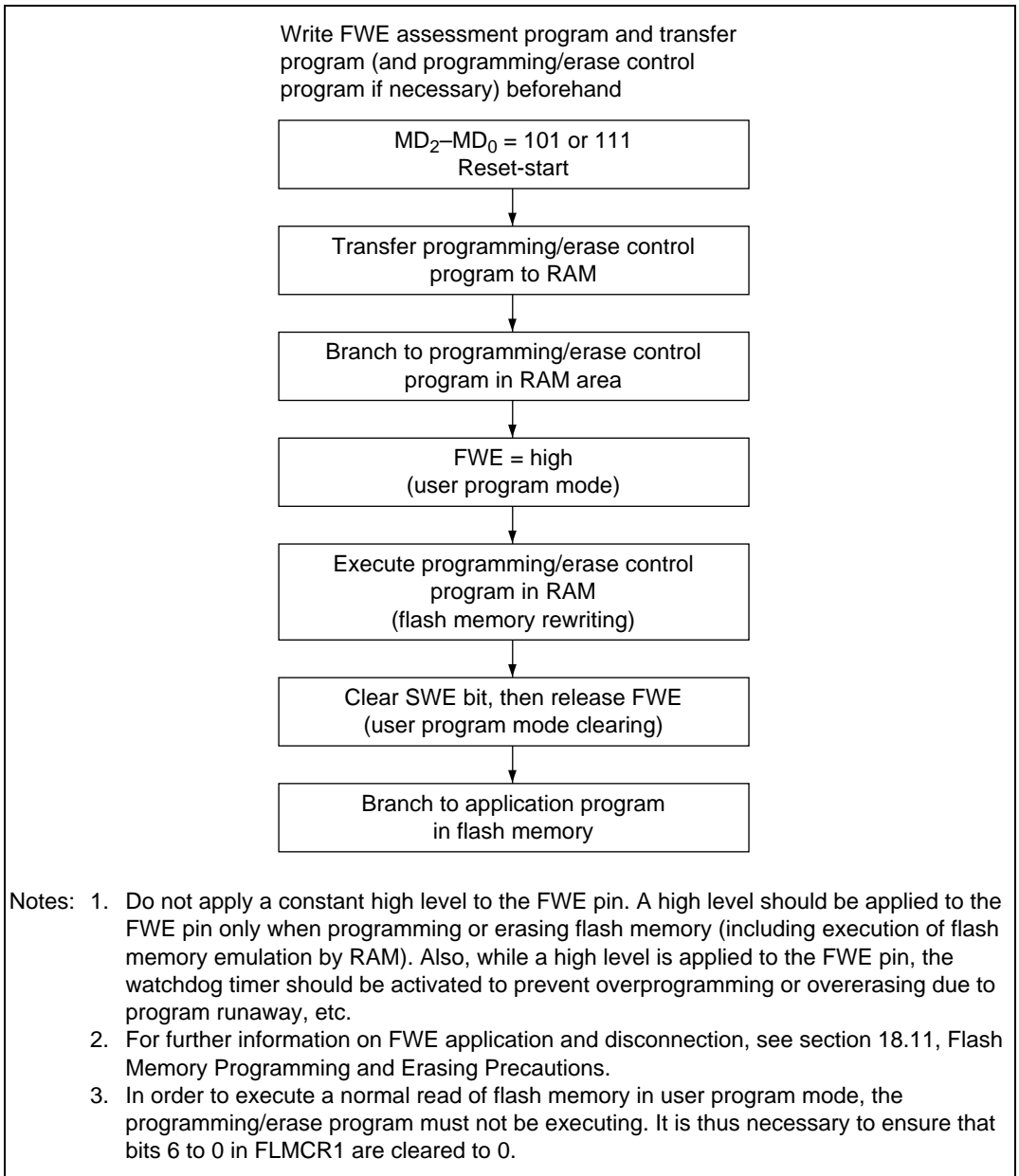

Figure 18.8 Example of User Program Mode Execution Procedure

18.6 Flash Memory Programming/Erasing

A software method, using the CPU, is employed to program and erase flash memory in the on-board programming modes. There are four flash memory operating modes: program mode, erase mode, program-verify mode, and erase-verify mode. Transitions to these modes for addresses H'000000 to H'03FFFF are made by setting the PSU, ESU, P, E, PV, and EV bits in FLMCR1.

The flash memory cannot be read while being programmed or erased. Therefore, the program (user program) that controls flash memory programming/erasing should be located and executed in on-chip RAM or external memory.

See section 18.11, Flash Memory Programming and Erasing Precautions, for points to be noted when programming or erasing the flash memory. In the following operation descriptions, wait times after setting or clearing individual bits in FLMCR1 are given as parameters; for details of the wait times, see section 21.1.6, Flash Memory Characteristics.

- Notes:
1. Operation is not guaranteed if setting/resetting of the SWE, ESU, PSU, EV, PV, E, and P bits in FLMCR1 is executed by a program in flash memory.
 2. When programming or erasing, set FWE to 1 (programming/erasing will not be executed if FWE = 0).
 3. Programming must be executed in the erased state. Do not perform additional programming on addresses that have already been programmed.

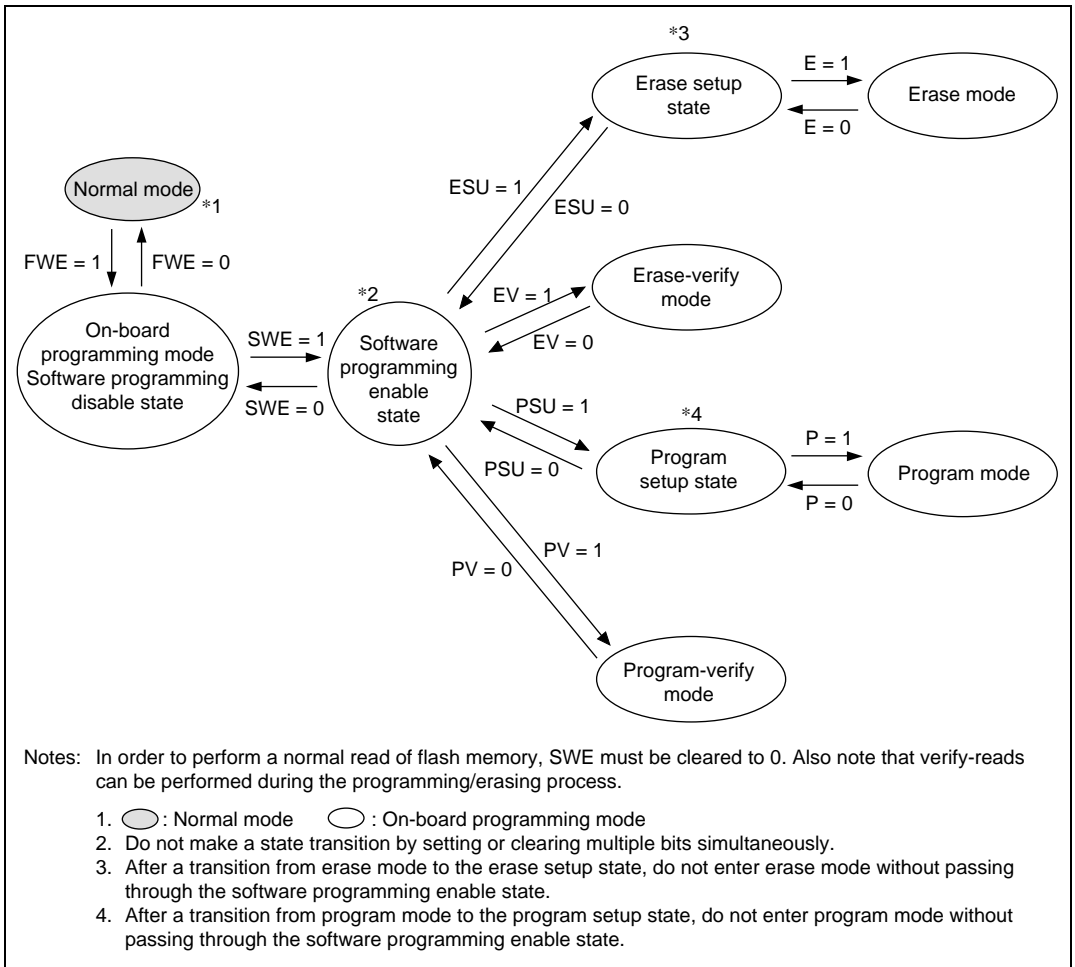

Figure 18.9 FLMCR1 Bit Settings and State Transitions

18.6.1 Program Mode

When writing data or programs to flash memory, the program/program-verify flowchart shown in figure 18.10 should be followed. Performing programming operations according to this flowchart will enable data or programs to be written to flash memory without subjecting the device to voltage stress or sacrificing program data reliability. Programming should be carried out 128 bytes at a time.

The wait times after bits are set or cleared in the flash memory control register 1 (FLMCR1) and the maximum number of programming operations (N) are shown in table 21.10 in section 21.1.6, Flash Memory Characteristics.

Following the elapse of (t_{sswe}) μ s or more after the SWE bit is set to 1 in FLMCR1, 128-byte data is written consecutively to the write addresses. The lower 8 bits of the first address written to must be H'00 and H'80, 128 consecutive byte data transfers are performed. The program address and program data are latched in the flash memory. A 128-byte data transfer must be performed even if writing fewer than 128 bytes; in this case, H'FF data must be written to the extra addresses.

Next, the watchdog timer (WDT) is set to prevent overprogramming due to program runaway, etc. Set a value greater than ($t_{spsu} + t_{sp} + t_{cp} + t_{cpsu}$) μ s as the WDT overflow period. Preparation for entering program mode (program setup) is performed next by setting the PSU bit in FLMCR1. The operating mode is then switched to program mode by setting the P bit in FLMCR1 after the elapse of at least (t_{spsu}) μ s. The time during which the P bit is set is the flash memory programming time. Make a program setting so that the time for one programming operation is within the range of (t_{sp}) μ s.

The wait time after P bit setting must be changed according to the degree of progress through the programming operation. For details see “Notes on Program/Program-Verify Mode.”

18.6.2 Program-Verify Mode

In program-verify mode, the data written in program mode is read to check whether it has been correctly written in the flash memory.

After the elapse of the given programming time, clear the P bit in FLMCR1, then wait for at least (t_{cp}) μ s before clearing the PSU bit to exit program mode. After exiting program mode, the watchdog timer setting is also cleared. The operating mode is then switched to program-verify mode by setting the PV bit in FLMCR1. Before reading in program-verify mode, a dummy write of H'FF data should be made to the addresses to be read. The dummy write should be executed after the elapse of (t_{spv}) μ s or more. When the flash memory is read in this state (verify data is read in 16-bit units), the data at the latched address is read. Wait at least (t_{spvr}) μ s after the dummy write before performing this read operation. Next, the originally written data is compared with the verify data, and reprogram data is computed (see figure 18.10) and transferred to RAM. After verification of 128 bytes of data has been completed, exit program-verify mode, wait for at least (t_{cpv}) μ s, then clear the SWE bit in FLMCR1. If reprogramming is necessary, set program mode again, and repeat the program/program-verify sequence as before. The maximum number of repetitions of the program/program-verify sequence is indicated by the maximum programming count (N). Leave a wait time of at least (t_{cswe}) μ s after clearing SWE.

Notes on Program/Program-Verify Procedure

1. The program/program-verify procedure for the H8/3068F-ZTAT uses a 128-byte-unit programming algorithm.
In order to perform 128-byte-unit programming, the lower 8 bits of the write start address must be H'00 or H'80.
2. When performing continuous writing of 128-byte data to flash memory, byte-unit transfer should be used.
128-byte data transfer is necessary even when writing fewer than 128 bytes of data. Write H'FF data to the extra addresses.
3. Verify data is read in word units.
4. The write pulse is applied and a flash memory write executed while the P bit in FLMCR1 is set. In the H8/3068F-ZTAT, write pulses should be applied as follows in the program/program-verify procedure to prevent voltage stress on the device and loss of write data reliability.
 - a. After write pulse application, perform a verify-read in program-verify mode and apply a write pulse again for any bits read as 1 (reprogramming processing). When all the 0-write bits in the 128-byte write data are read as 0 in the verify-read operation, the program/program-verify procedure is completed. In the H8/3068F-ZTAT, the number of

loops in reprogramming processing is guaranteed not to exceed the maximum value of the maximum programming count (N).

- b. After write pulse application, a verify-read is performed in program-verify mode, and programming is judged to have been completed for bits read as 0. The following processing is necessary for programmed bits.

When programming is completed at an early stage in the program/program-verify procedure:

If programming is completed in the 1st to 6th reprogramming processing loop, additional programming should be performed on the relevant bits. Additional programming should only be performed on bits which first return 0 in a verify-read in certain reprogramming processing.

When programming is completed at a late stage in the program/program-verify procedure:

If programming is completed in the 7th or later reprogramming processing loop, additional programming is not necessary for the relevant bits.

- c. If programming of other bits is incomplete in the 128 bytes, reprogramming processing should be executed. If a bit for which programming has been judged to be completed is read as 1 in a subsequent verify-read, a write pulse should again be applied to that bit.
5. The period for which the P bit in FLMCR1 is set (the write pulse width) should be changed according to the degree of progress through the program/program-verify procedure. For detailed wait time specifications, see section 21.1.6, Flash Memory Characteristics.

Item	Symbol	Item	Symbol
Wait time after P bit setting	t_{sp}	When reprogramming loop count (n) is 1 to 6	t_{sp30}
		When reprogramming loop count (n) is 7 or more	t_{sp200}
		In case of additional programming processing*	t_{sp10}

Note: * Additional programming processing is necessary only when the reprogramming loop count (n) is 1 to 6.

6. The program/program-verify flowchart for the H8/3068F-ZTAT is shown in figure 18.10. To cover the points noted above, bits on which reprogramming processing is to be executed, and bits on which additional programming is to be executed, must be determined as shown below.
- Since reprogram data and additional-programming data vary according to the progress of the programming procedure, it is recommended that the following data storage areas (128 bytes each) be provided in RAM.

Reprogram Data Computation Table

(D)	Result of Verify-Read after Write Pulse Application (V)	(X) Result of Operation	Comments
0	0	1	Programming completed: reprogramming processing not to be executed
0	1	0	Programming incomplete: reprogramming processing to be executed
1	0	1	—
1	1	1	Still in erased state: no action

Legend

(D): Source data of bits on which programming is executed

(X): Source data of bits on which reprogramming is executed

Additional-Programming Data Computation Table

(X')	Result of Verify-Read after Write Pulse Application (V)	(Y) Result of Operation	Comments
0	0	0	Programming by write pulse application judged to be completed: additional programming processing to be executed
0	1	1	Programming by write pulse application incomplete: additional programming processing not to be executed
1	0	1	Programming already completed: additional programming processing not to be executed
1	1	1	Still in erased state: no action

Legend

(Y): Data of bits on which additional programming is executed

(X'): Data of bits on which reprogramming is executed in a certain reprogramming loop

- It is necessary to execute additional programming processing during the course of the H8/3068F-ZTAT program/program-verify procedure. However, once 128-byte-unit programming is finished, additional programming should not be carried out on the same address area. When executing reprogramming, an erase must be executed first. Note that normal operation of reads, etc., is not guaranteed if additional programming is performed on addresses for which a program/program-verify operation has finished.

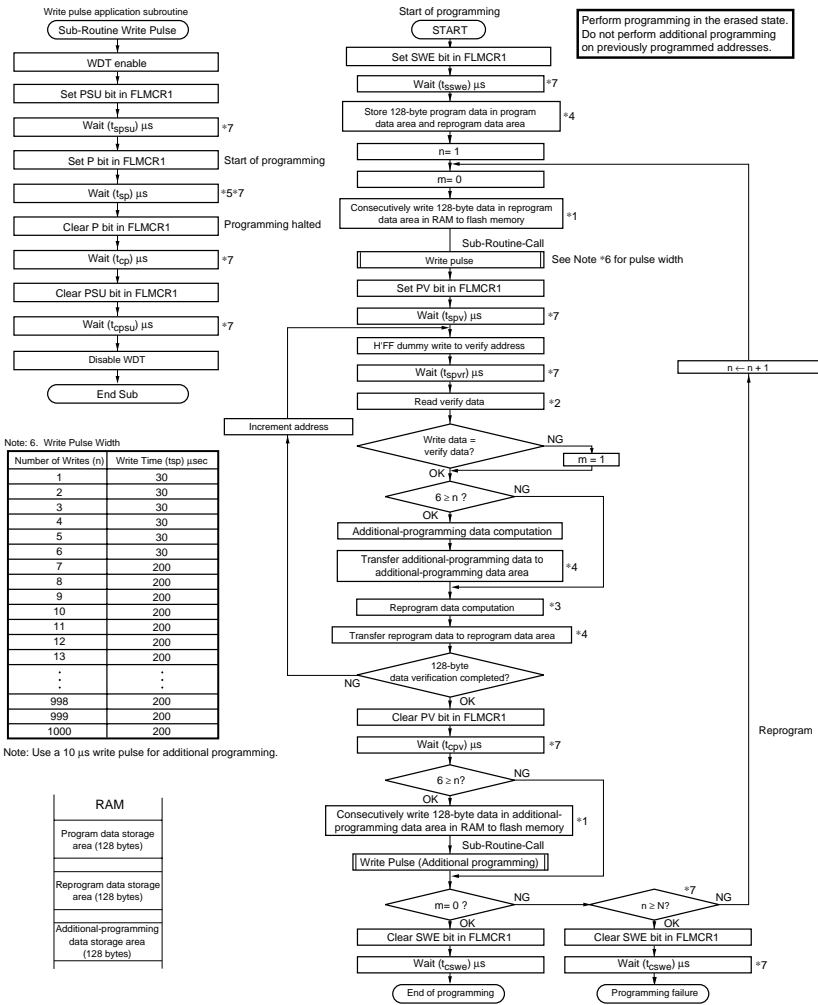

- Notes:
- Data transfer is performed by byte transfer. The lower 8 bits of the first address written to must be H00 or H80. A 128-byte data transfer must be performed even if writing fewer than 128 bytes; in this case, HFF data must be written to the extra addresses.
 - Verify data is read in 16-bit (word) units.
 - Reprogram data is determined by the operation shown in the table below (comparison between the data stored in the program data area and the verify data). Bits for which the reprogram data is 0 are programmed in the next reprogramming loop. Therefore, even bits for which programming has been completed will be subjected to programming once again if the result of the subsequent verify operation is NG.
 - A 128-byte area for storing program data, a 128-byte area for storing reprogram data, and a 128-byte area for storing additional-programming data must be provided in RAM. The contents of the reprogram data area and additional-programming data area are modified as programming proceeds.
 - A write pulse of 30 μ s or 200 μ s is applied according to the progress of the programming operation. See Note 6 for details of the pulse widths. When writing of additional-programming data is executed, a 10 μ s write pulse should be applied. Reprogram data X means reprogram data when the write pulse is applied.
 - The wait times and value of N are shown in section 21.1.6, Flash Memory Characteristics.

Reprogram Data Computation Table

Original Data (D)	Verify Data (V)	Reprogram Data (X)	Comments
0	0	1	Programming completed
0	1	0	Programming incomplete; reprogram
1	0	1	
1	1	1	Still in erased state; no action

Additional-Programming Data Computation Table

Reprogram Data (X)	Verify Data (V)	Additional-Programming Data (Y)	Comments
0	0	0	Additional programming to be executed
0	1	1	Additional programming not to be executed
1	0	1	Additional programming not to be executed
1	1	1	Additional programming not to be executed

Figure 18.10 Program/Program-Verify Flowchart (128-Byte Programming)

18.6.3 Erase Mode

When erasing flash memory, the single-block erase flowchart shown in figure 18.11 should be followed.

The wait times after bits are set or cleared in the flash memory control register 1 (FLMCR1) and the maximum number of erase operations (N) are shown in table 21.10 in section 21.1.6, Flash Memory Characteristics.

To erase flash memory contents, make a 1-bit setting for the flash memory area to be erased in erase block register 1 and 2 (EBR1, EBR2) at least (t_{sswe}) μ s after setting the SWE bit to 1 in FLMCR1. Next, the watchdog timer (WDT) is set to prevent overerasing due to program runaway, etc. Set a value greater than (t_{se}) ms + ($t_{sesu} + t_{ce} + t_{cesu}$) μ s as the WDT overflow period. Preparation for entering erase mode (erase setup) is performed next by setting the ESU bit in FLMCR1. The operating mode is then switched to erase mode by setting the E bit in FLMCR1 after the elapse of at least (t_{sesu}) μ s. The time during which the E bit is set is the flash memory erase time. Ensure that the erase time does not exceed (t_{se}) ms.

Note: With flash memory erasing, preprogramming (setting all memory data in the memory to be erased to all 0) is not necessary before starting the erase procedure.

18.6.4 Erase-Verify Mode

In erase-verify mode, data is read after memory has been erased to check whether it has been correctly erased.

After the elapse of the fixed erase time, clear the E bit in FLMCR1, then wait for at least (t_{ce}) μ s before clearing the ESU bit to exit erase mode. After exiting erase mode, the watchdog timer setting is also cleared. The operating mode is then switched to erase-verify mode by setting the EV bit in FLMCR1. Before reading in erase-verify mode, a dummy write of H'FF data should be made to the addresses to be read. The dummy write should be executed after the elapse of (t_{sev}) μ s or more. When the flash memory is read in this state (verify data is read in 16-bit units), the data at the latched address is read. Wait at least (t_{sevr}) μ s after the dummy write before performing this read operation. If the read data has been erased (all 1), a dummy write is performed to the next address, and erase-verify is performed. If the read data is unerased, set erase mode again, and repeat the erase/erase-verify sequence as before. The maximum number of repetitions of the erase/erase-verify sequence is indicated by the maximum erase count (N). When verification is completed, exit erase-verify mode, and wait for at least (t_{cev}) μ s. If erasure has been completed on all the erase blocks, clear the SWE bit in FLMCR1, and leave a wait time of at least (t_{cswe}) μ s.

If erasing multiple blocks, set a single bit in EBR1/EBR2 for the next block to be erased, and repeat the erase/erase-verify sequence as before.

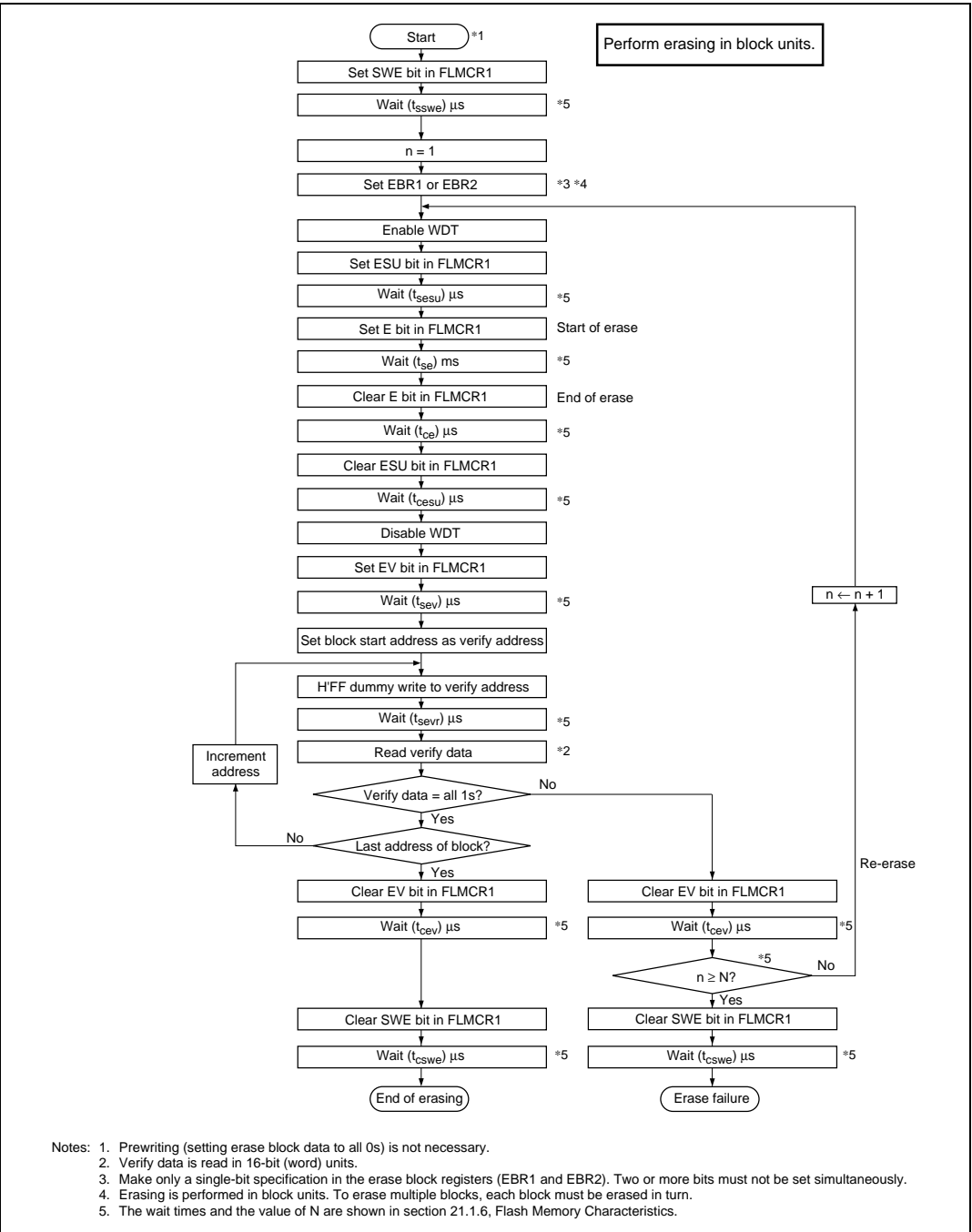

Figure 18.11 Erase/Erase-Verify Flowchart (Single-Block Erasing)

18.7 Flash Memory Protection

There are three kinds of flash memory program/erase protection: hardware, software, and error protection.

18.7.1 Hardware Protection

Hardware protection refers to a state in which programming/erasing of flash memory is forcibly disabled or aborted. In this state, the settings in flash memory control register 1 (FLMCR1) and erase block registers 1 and 2 (EBR1, EBR2) are reset. In the error protection state, the FLMCR1, EBR1, and EBR2 settings are retained; the P bit and E bit can be set, but a transition is not made to program mode or erase mode. (See table 18.8.)

Table 18.8 Hardware Protection

Item	Description	Function		
		Program	Erase	Verify
FWE pin protection	<ul style="list-style-type: none"> When a low level is input to the FWE pin, FLMCR1, EBR1, and EBR2 are initialized, and the program/erase-protected state is entered. 	Not possible* ¹	Not possible* ³	Not possible
Reset/standby protection	<ul style="list-style-type: none"> In a reset (including a WDT overflow reset) and in standby mode, FLMCR1, FLMCR2, EBR1, and EBR2 are initialized, and the program/erase-protected state is entered. In a reset via the $\overline{\text{RES}}$ pin, the reset state is not entered unless the $\overline{\text{RES}}$ pin is held low until oscillation stabilizes after powering on. In the case of a reset during operation, hold the $\overline{\text{RES}}$ pin low for the $\overline{\text{RES}}$ pulse width specified in the AC Characteristics section.*⁴ 	Not possible	Not possible* ³	Not possible
Error protection	<ul style="list-style-type: none"> When a microcomputer operation error (error generation (FLER = 1)) was detected while flash memory was being programmed/erased, error protection is enabled. At this time, the FLMCR1, EBR1, and EBR2 settings are held, but programming/erasing is aborted at the time the error was generated. Error protection is released only by a reset via the $\overline{\text{RES}}$ pin or a WDT reset, or in the hardware standby mode. 	Not possible	Not possible* ³	Possible* ²

Notes: 1. The RAM area that overlapped flash memory is deleted.

2. It is possible to perform a program-verify operation on the 128 bytes being programmed, or an erase-verify operation on the block being erased.
3. All blocks are unerasable and block-by-block specification is not possible.
4. See section 4.2.2, Reset Sequence, and section 18.11, Flash Memory Programming and Erasing Precautions. The H8/3068F-ZTAT requires a minimum of 20 system clock cycles for a reset during operation.

18.7.2 Software Protection

Software protection can be implemented by setting the erase block register 1 (EBR1), erase block register 2 (EBR2), and the RAMS bit in the RAM control register (RAMCR). With software protection, setting the P or E bit in the flash memory control register 1 (FLMCR1) does not cause a transition to program mode or erase mode. (See table 18.9.)

Table 18.9 Software Protection

Item	Description	Functions		
		Program	Erase	Verify
Block protection	<ul style="list-style-type: none"> • Erase protection can be set for individual blocks by settings in erase block register 1 (EBR1) and erase block register 2 (EBR2)*². However, programming protection is disabled. • Setting EBR1 and EBR2 to H'00 places all blocks in the erase-protected state. 	—	Not possible	Possible
Emulation protection	<ul style="list-style-type: none"> • Setting the RAMS bit 1 in RAMCR places all blocks in the program/erase-protected state. 	Not possible* ¹	Not possible* ³	Possible

- Notes:
1. The RAM area overlapping flash memory can be written to.
 2. When not erasing, set EBR1 and EBR2 to H'00.
 3. All blocks are unerasable and block-by-block specification is not possible.

18.7.3 Error Protection

In error protection, an error is detected when MCU runaway occurs during flash memory programming/erasing*¹, or operation is not performed in accordance with the program/erase algorithm, and the program/erase operation is aborted. Aborting the program/erase operation prevents damage to the flash memory due to overprogramming or overerasing.

If the MCU malfunctions during flash memory programming/erasing, the FLER bit is set to 1 in the flash memory status register (FLMSR2) and the error protection state is entered. FLMCR1, FLMCR2, EBR1, and EBR2 settings*³ are retained, but program mode or erase mode is aborted at the point at which the error occurred. Program mode or erase mode cannot be re-entered by re-setting the P or E bit in FLMCR. However, PV and EV bit setting is enabled, and a transition can be made to verify mode*².

FLER bit setting conditions are as follows:

1. When flash memory is read during programming/erasing (including a vector read or instruction fetch)
 2. Immediately after the start of exception handling during programming/erasing (excluding reset, illegal instruction, trap instruction, and division-by-zero exception handling)
 3. When a SLEEP instruction (including software standby) is executed during programming/erasing
 4. When the bus is released during programming/erasing
- Error protection is released only by a $\overline{\text{RES}}$ pin or WDT reset, or in hardware standby mode.

- Notes:
1. State in which the P bit or E bit in FLMCR1 is set to 1. Note that NMI input is disabled in this state.
 2. It is possible to perform a program-verify operation on the 128 bytes being programmed, or an erase-verify on the block being erased.
 3. FLMCR1, EBR1, and EBR2 can be written to. However, the registers are initialized if a transition is made to software standby mode while in the error protection state.

Figure 18.12 shows the flash memory state transition diagram.

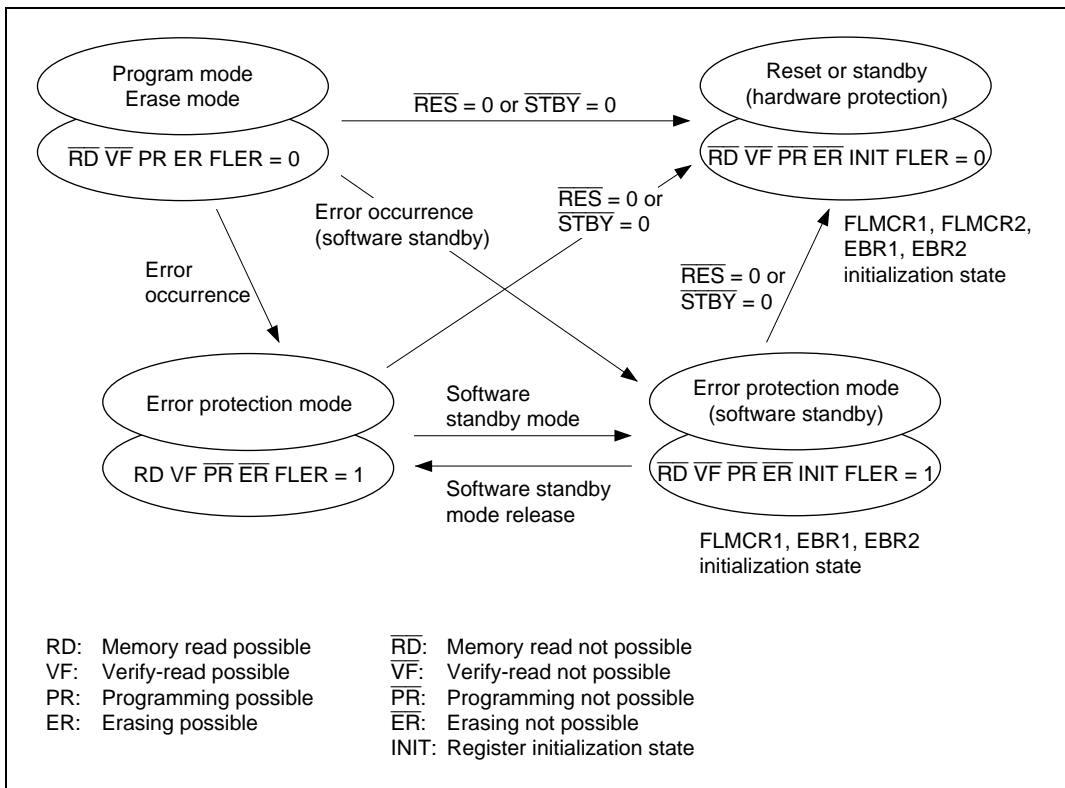

Figure 18.12 Flash Memory State Transitions

(When High Level is Applied to FWE Pin in Mode 5 or 7 (On-Chip ROM Enabled))

The error protection function is invalid for abnormal operations other than the FLER bit setting conditions. Also, if a certain time has elapsed before this protection state is entered, damage may already have been caused to the flash memory. Consequently, this function cannot provide complete protection against damage to flash memory.

To prevent such abnormal operations, therefore, it is necessary to ensure correct operation in accordance with the program/erase algorithm, with the flash write enable (FWE) voltage applied, and to conduct constant monitoring for MCU errors, internally and externally, using the watchdog timer or other means. There may also be cases where the flash memory is in an erroneous programming or erroneous erasing state at the point of transition to this protection mode, or where programming or erasing is not properly carried out because of an abort. In cases such as these, a forced recovery (program rewrite) must be executed using boot mode. However, it may also happen that boot mode cannot be normally initiated because of overprogramming or overerasing.

18.8 Flash Memory Emulation in RAM

Making a setting in the RAM control register (RAMCR) enables part of RAM to be overlapped onto the flash memory area so that data to be written to flash memory can be emulated in RAM in real time. After the RAMCR setting has been made, accesses can be made from the flash memory area or the RAM area overlapping flash memory. Emulation can be performed in user mode and user program mode. Figure 18.13 shows an example of emulation of realtime flash memory programming.

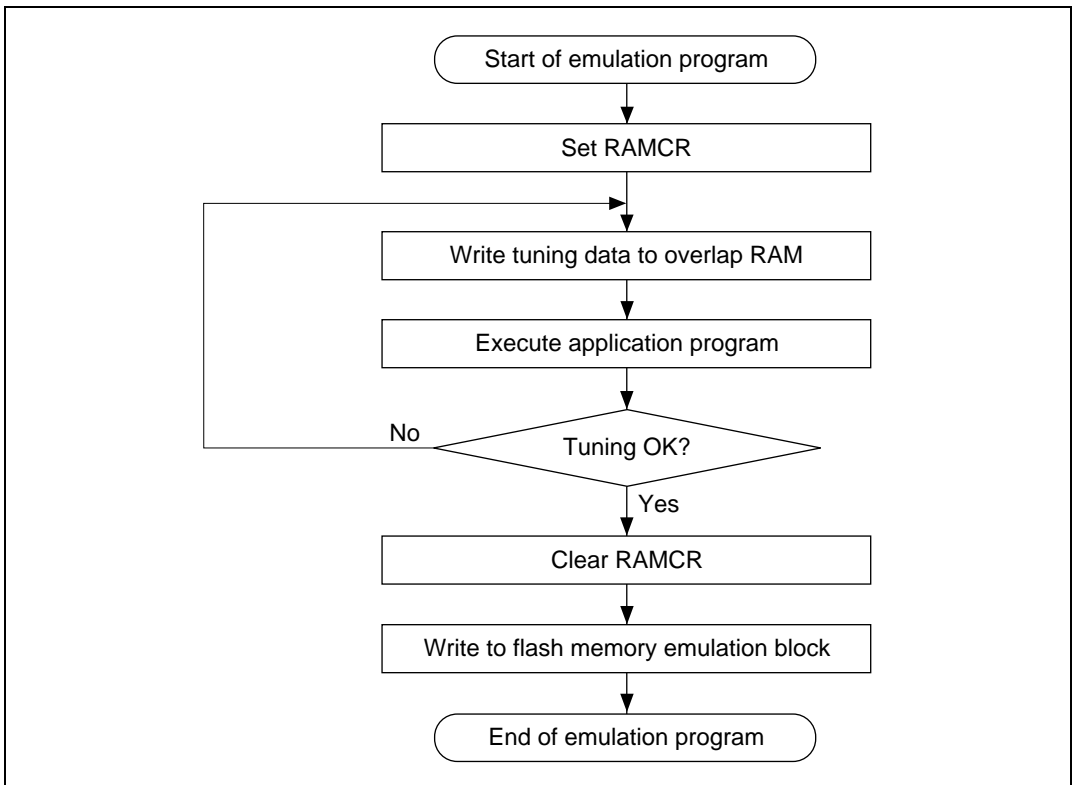

Figure 18.13 Flowchart of Flash Memory Emulation in RAM

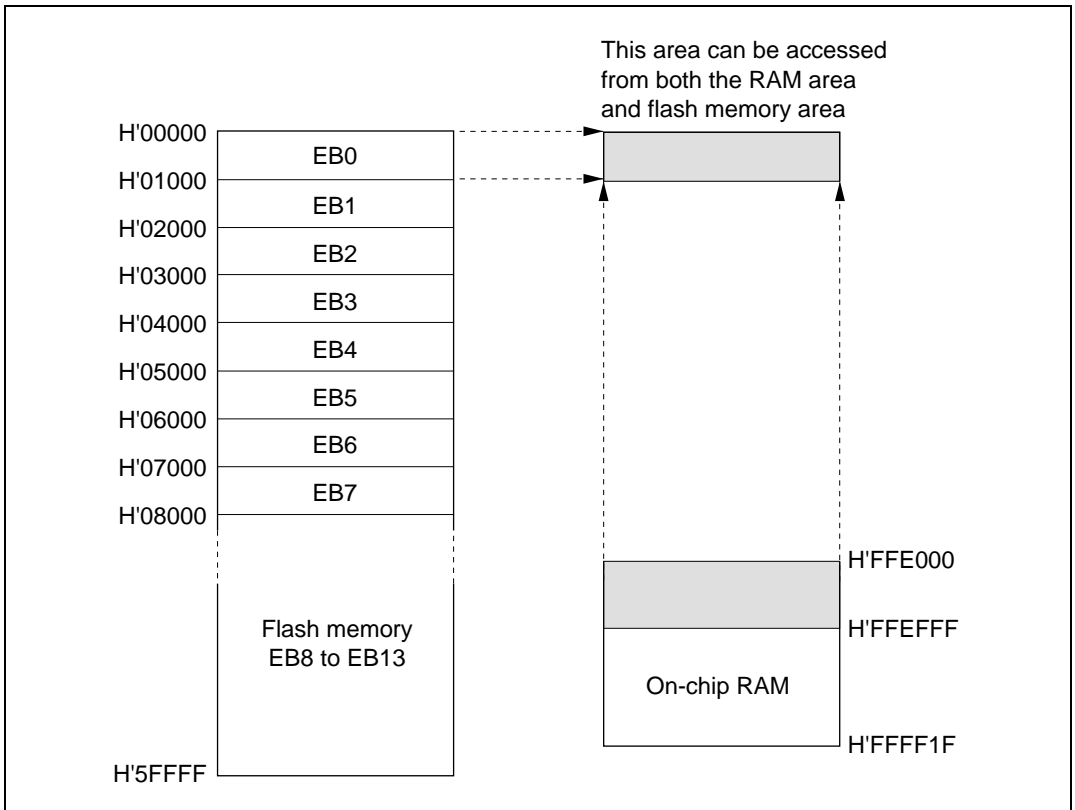

Figure 18.14 Example of RAM Overlap Operation

Example of Flash Memory Block Area EB0 Overlapping

1. Set bits RAMS and RAM2 to RAM0 in RAMCR to 1,0, 0, 0, to overlap part of RAM onto the area (EB0) for which realtime programming is required.
2. Realtime programming is performed using the overlapping RAM.
3. After the program data has been confirmed, the RAMS bit is cleared, releasing RAM overlap.
4. The data written in the overlapping RAM is written into the flash memory space (EB0).

- Notes:
1. When the RAMS bit is set to 1, program/erase protection is enabled for all blocks regardless of the value of RAM2 to RAM0 (emulation protection). In this state, setting the P or E bit in FLMCR1 will not cause a transition to program mode or erase mode. When actually programming or erasing a flash memory area, the RAMS bit should be cleared to 0.
 2. A RAM area cannot be erased by execution of software in accordance with the erase algorithm while flash memory emulation in RAM is being used.

3. Block area EBO contains the vector table. When performing RAM emulation, the vector table is needed in the overlap RAM.
4. As in on-board programming mode, care is required when applying and releasing FWE to prevent erroneous programming or erasing. To prevent erroneous programming and erasing due to program runaway during FWE application, in particular, the watchdog timer should be set when the PSU, P, ESU, or E bit is set to 1 in FLMCR1, even while the emulation function is being used.
5. When the emulation function is used, NMI input is prohibited when the P bit or E bit is set to 1 in FLMCR1, in the same way as with normal programming and erasing. The P and E bits are cleared by a reset (including a watchdog timer reset), in standby mode, when a high level is not being input to the FWE pin, or when the SWE bit in FLMCR1 is 0 while a high level is being input to the FWE pin.

18.9 NMI Input Disabling Conditions

All interrupts, including NMI input, should be disabled while flash memory is being programmed or erased (while the P bit or E bit is set in FLMCR1), and while the boot program is executing in boot mode*¹, to give priority to the program or erase operation. There are three reasons for this:

1. NMI input during programming or erasing might cause a violation of the programming or erasing algorithm, with the result that normal operation could not be assured.
2. In the NMI exception handling sequence during programming or erasing, the vector would not be read correctly*², possibly resulting in MCU runaway.
3. If NMI input occurred during boot program execution, it would not be possible to execute the normal boot mode sequence.

For these reasons, in on-board programming mode alone there are conditions for disabling NMI input, as an exception to the general rule. However, this provision does not guarantee normal erasing and programming or MCU operation. All interrupt requests (exception handling and bus release), including NMI, must therefore be restricted inside and outside the MCU during FWE application. NMI input is also disabled in the error protection state and while the P or E bit remains set in FLMCR1 during flash memory emulation in RAM.

- Notes:
1. This is the interval until a branch is made to the boot program area in the on-chip RAM (This branch takes place immediately after transfer of the user program is completed). Consequently, after the branch to the RAM area, NMI input is enabled except during programming and erasing. Interrupt requests must therefore be disabled inside and outside the MCU until the user program has completed initial programming (including the vector table and the NMI interrupt handling routine).
 2. The vector may not be read correctly in this case for the following two reasons:
 - If flash memory is read while being programmed or erased (while the P bit or E bit is set in FLMCR1), correct read data will not be obtained (undetermined values will be returned).
 - If the entry in the interrupt vector table has not been programmed yet, interrupt exception handling will not be executed correctly.

18.10 Flash Memory PROM Mode

The H8/3068F-ZTAT has a PROM mode as well as the on-board programming modes for programming and erasing flash memory. In PROM mode, the on-chip ROM can be freely programmed using a general-purpose PROM writer that supports the Renesas Technology microcomputer device type with 256-kbyte on-chip flash memory.

18.10.1 Socket Adapters and Memory Map

In PROM mode using a PROM writer, memory reading (verification) and writing and flash memory initialization (total erasure) can be performed. For these operations, a special socket adapter is mounted in the PROM writer. The socket adapter product codes are given in table 18.10. In the H8/3068F-ZTAT PROM mode, only the socket adapters shown in this table should be used.

Table 18.10 H8/3068F-ZTAT Socket Adapter Product Codes

Product Code	Package	Socket Adapter Product Code	Manufacturer
HD64F3068F	100-pin QFP (FP-100B)	ME3064ESHF1H	MINATO
HD64F3068TE	100-pin TQFP (TFP-100B)	ME3064ESNF1H	ELECTRONICS INC.
HD64F3068F	100-pin QFP (FP-100B)	HF306BQ100D4001	DATA I/O JAPAN CO.
HD64F3068TE	100-pin TQFP (TFP-100B)	HF306BT100D4001	

Figure 18.15 shows the memory map in PROM mode.

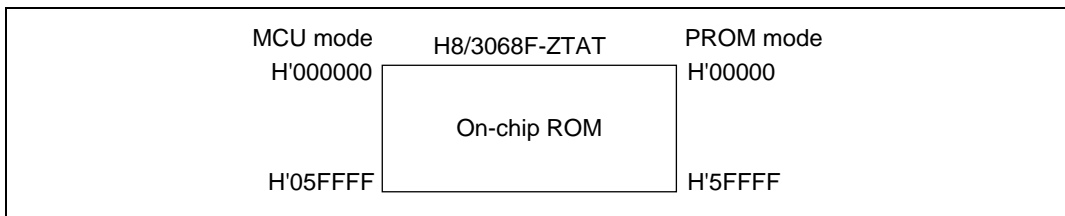

Figure 18.15 Memory Map in PROM Mode

18.10.2 Notes on Use of PROM Mode

1. A write to a 128-byte programming unit in PROM mode should be performed once only. Erasing must be carried out before reprogramming an address that has already been programmed.
2. When using a PROM writer to reprogram a device on which on-board programming/erasing has been performed, it is recommended that erasing be carried out before executing programming.
3. The memory is initially in the erased state when the device is shipped by Renesas Technology. For samples for which the erasure history is unknown, it is recommended that erasing be executed to check and correct the initialization (erase) level.
4. The H8/3068F-ZTAT does not support a product identification mode as used with general-purpose EPROMs, and therefore the device name cannot be set automatically in the PROM writer.
5. Refer to the instruction manual provided with the socket adapter, or other relevant documentation, for information on PROM writers and associated program versions that are compatible with the PROM mode of the H8/3068F-ZTAT.

18.11 Flash Memory Programming and Erasing Precautions

Precautions concerning the use of on-board programming mode, the RAM emulation function, and PROM mode are summarized below.

1. Use the specified voltages and timing for programming and erasing.

Applied voltages in excess of the rating can permanently damage the device. Use a PROM programmer that supports the Renesas Technology microcomputer device type “F-ZTAT512” with 512-kbyte on-chip flash memory.

2. Powering on and off (see figures 18.16 to 18.18)

Do not apply a high level to the FWE pin until V_{CC} has stabilized. Also, drive the FWE pin low before turning off V_{CC} .

When applying or disconnecting V_{CC} power, fix the FWE pin low and place the flash memory in the hardware protection state.

The power-on and power-off timing requirements should also be satisfied in the event of a power failure and subsequent recovery. Failure to do so may result in overprogramming or overerasing due to MCU runaway, and loss of normal memory cell operation.

3. FWE application/disconnection

FWE application should be carried out when MCU operation is in a stable condition. If MCU operation is not stable, fix the FWE pin low and set the protection state.

The following points must be observed concerning FWE application and disconnection to prevent unintentional programming or erasing of flash memory:

- Apply FWE when the V_{CC} voltage has stabilized within its rated voltage range.
If FWE is applied when the MCU's V_{CC} power supply is not within its rated voltage range, MCU operation will be unstable and flash memory may be erroneously programmed or erased.

- Apply FWE when oscillation has stabilized (after the elapse of the oscillation settling time).

When V_{CC} power is turned on, hold the \overline{RES} pin low for the duration of the oscillation settling time before applying FWE. Do not apply FWE when oscillation has stopped or is unstable.

- In boot mode, apply and disconnect FWE during a reset.

In a transition to boot mode, FWE = 1 input and MD₂–MD₀ setting should be performed while the \overline{RES} input is low. FWE and MD₂–MD₀ pin input must satisfy the mode programming setup time (t_{MDS}) with respect to the reset release timing. When making a transition from boot mode to another mode, also, a mode programming setup time is necessary with respect to the reset release timing.

In a reset during operation, the $\overline{\text{RES}}$ pin must be held low for a minimum of 20 system clock cycles.

- In user program mode, FWE can be switched between high and low level regardless of $\overline{\text{RES}}$ input.

FWE input can also be switched during execution of a program in flash memory.

- Do not apply FWE if program runaway has occurred.

During FWE application, the program execution state must be monitored using the watchdog timer or some other means.

- Disconnect FWE only when the SWE, ESU, PSU, EV, PV, E, and P bits in FLMCR1 are cleared.

Make sure that the SWE, ESU, PSU, EV, PV, E, and P bits are not set by mistake when applying or disconnecting FWE.

4. Do not apply a constant high level to the FWE pin.

To prevent erroneous programming or erasing due to program runaway, etc., apply a high level to the FWE pin only when programming or erasing flash memory (including execution of flash memory emulation using RAM). A system configuration in which a high level is constantly applied to the FWE pin should be avoided. Also, while a high level is applied to the FWE pin, the watchdog timer should be activated to prevent overprogramming or overerasing due to program runaway, etc.

5. Use the recommended algorithm when programming and erasing flash memory.

The recommended algorithm enables programming and erasing to be carried out without subjecting the device to voltage stress or sacrificing program data reliability. When setting the PSU or ESU bit in FLMCR1, the watchdog timer should be set beforehand as a precaution against program runaway, etc.

Also note that access to the flash memory space by means of a MOV instruction, etc., is not permitted while the P bit or E bit is set.

6. Do not set or clear the SWE bit during execution of a program in flash memory.

Clear the SWE bit before executing a program or reading data in flash memory. When the SWE bit is set, data in flash memory can be rewritten, but flash memory should only be accessed for verify operations (verification during programming/erasing).

Similarly, when using the RAM emulation function while a high level is being input to the FWE pin, the SWE bit must be cleared before executing a program or reading data in flash memory. However, the RAM area overlapping flash memory space can be read and written to regardless of whether the SWE bit is set or cleared.

A wait time is necessary after the SWE bit is cleared. For details see table 21.10 in section 21.1.6, Flash Memory Characteristics.

7. Do not use interrupts while flash memory is being programmed or erased.

All interrupt requests, including NMI, should be disabled during FWE application to give priority to program/erase operations (including emulation in RAM).

Bus release must also be disabled.

8. Do not perform additional programming. Erase the memory before reprogramming.

In on-board programming, perform only one programming operation on a 128-byte programming unit block. Programming should be carried out with the entire programming unit block erased.

9. Before programming, check that the chip is correctly mounted in the PROM writer.

Overcurrent damage to the device can result if the index marks on the PROM writer socket, socket adapter, and chip are not correctly aligned.

10. Do not touch the socket adapter or chip during programming.

Touching either of these can cause contact faults and write errors.

11. A wait time of 100 μ s or more is necessary when performing a read after a transition to normal mode from program, erase, or verify mode.**12. Use byte access on the registers that control the flash memory (FLMCR1, FLMCR2, EBR1, EBR2, and RAMCR).**

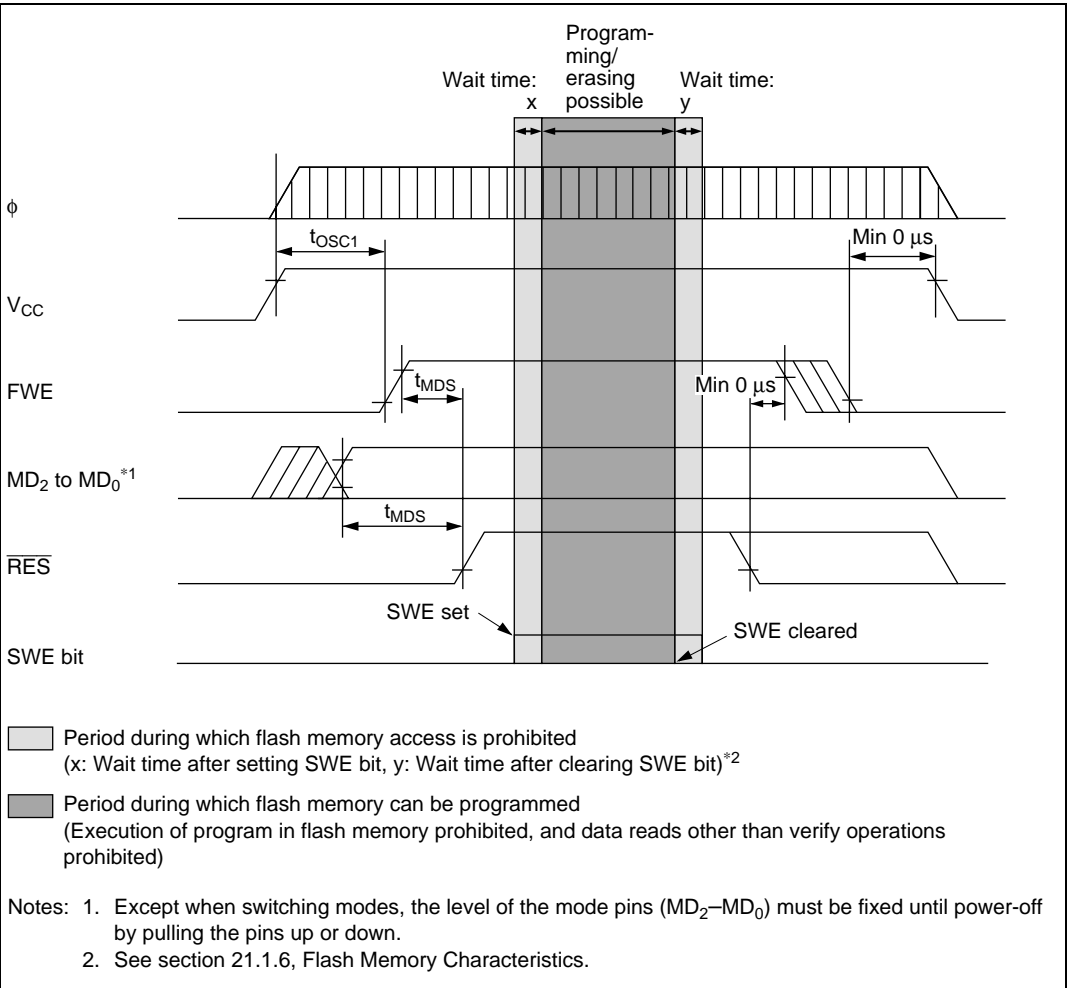

Figure 18.16 Power-On/Off Timing (Boot Mode)

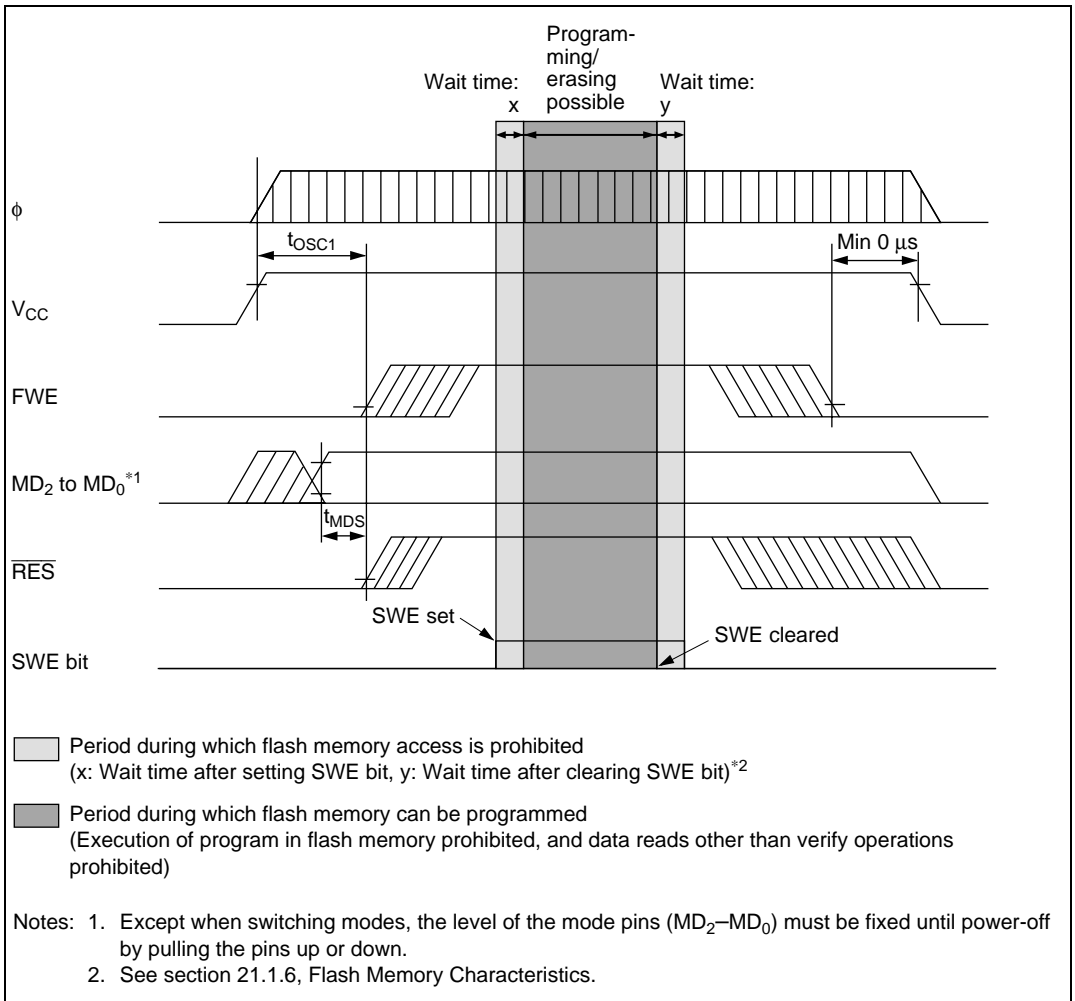

Figure 18.17 Power-On/Off Timing (User Program Mode)

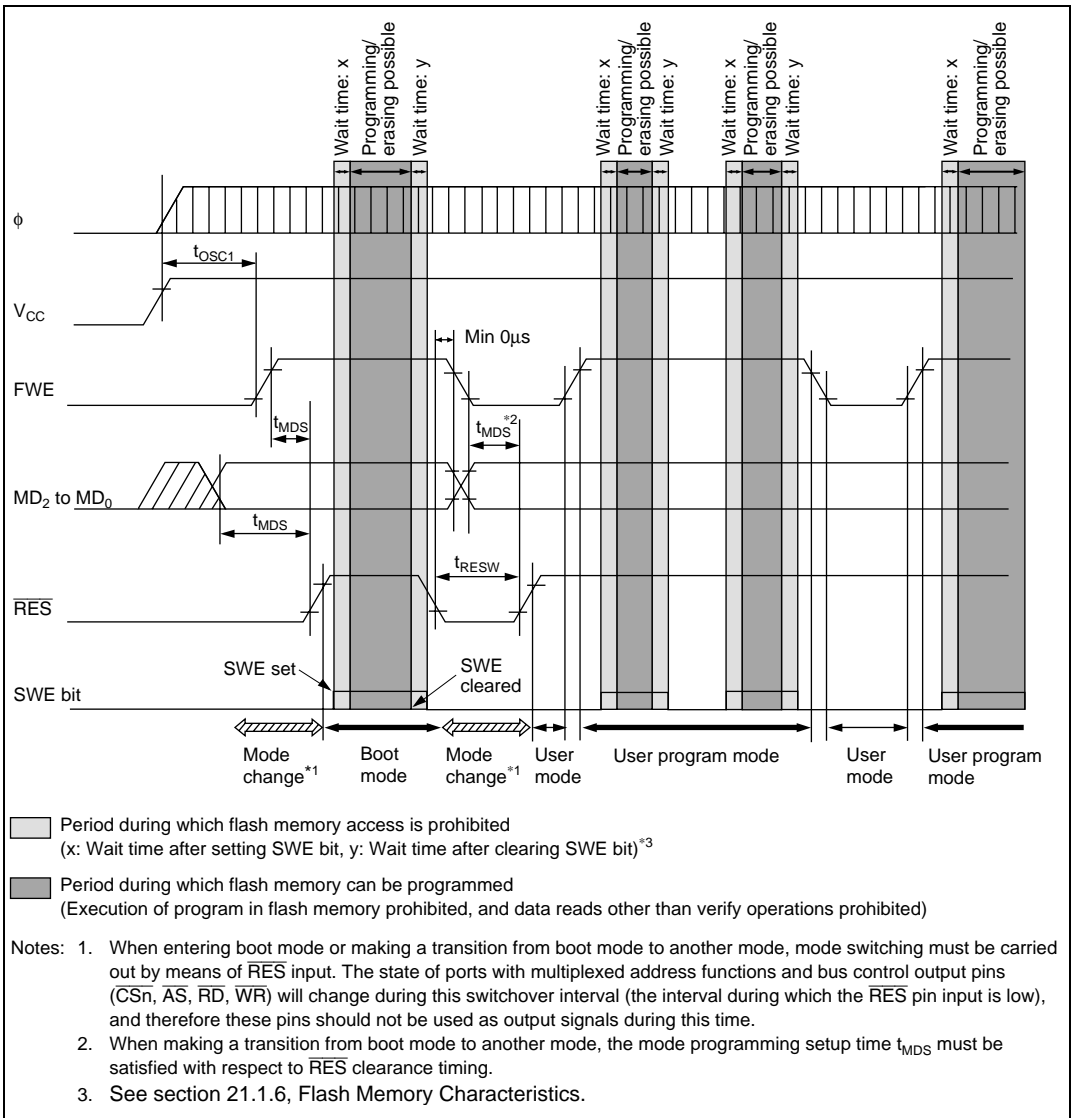

Figure 18.18 Mode Transition Timing
(Example: Boot Mode → User Mode ↔ User Program Mode)

Section 19 Clock Pulse Generator

19.1 Overview

The H8/3068F has a built-in clock pulse generator (CPG) that generates the system clock (ϕ) and other internal clock signals ($\phi/2$ to $\phi/4096$). After duty adjustment, a frequency divider divides the clock frequency to generate the system clock (ϕ). The system clock is output at the ϕ pin*¹ and furnished as a master clock to prescalers that supply clock signals to the on-chip supporting modules. Frequency division ratios of 1/1, 1/2, 1/4, and 1/8 can be selected for the frequency divider by settings in a division control register (DIVCR)*². Power consumption in the chip is reduced in almost direct proportion to the frequency division ratio.

- Notes:
1. Usage of the ϕ pin differs depending on the chip operating mode and the PSTOP bit setting in the module standby control register (MSTCR). For details, see section 20.7, System Clock Output Disabling Function.
 2. The division ratio of the frequency divider can be changed dynamically during operation. The clock output at the ϕ pin also changes when the division ratio is changed. The frequency output at the ϕ pin is shown below.

$$\phi = \text{EXTAL} \times n$$

where, EXTAL: Frequency of crystal resonator or external clock signal

n: Frequency division ratio (n = 1/1, 1/2, 1/4, or 1/8)

19.1.1 Block Diagram

Figure 19.1 shows a block diagram of the clock pulse generator.

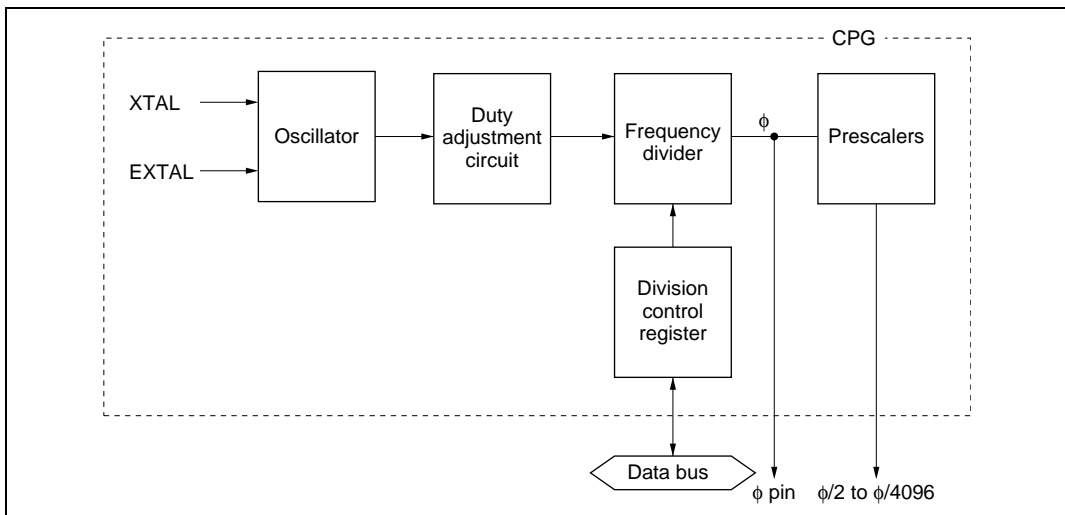

Figure 19.1 Block Diagram of Clock Pulse Generator

19.2 Oscillator Circuit

Clock pulses can be supplied by connecting a crystal resonator, or by input of an external clock signal.

19.2.1 Connecting a Crystal Resonator

Circuit Configuration: A crystal resonator can be connected as in the example in figure 19.2. Damping resistance R_d should be selected according to table 19.1 (1), and external capacitances C_{L1} and C_{L2} according to table 19.1 (2). An AT-cut parallel-resonance crystal should be used.

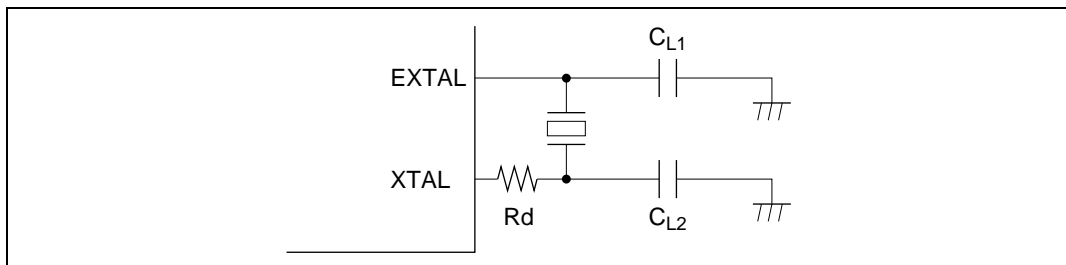

Figure 19.2 Connection of Crystal Resonator (Example)

If a crystal resonator with a frequency higher than 20 MHz is connected, the external load capacitance values in table 19.1 (2) should not exceed 10 [pF]. Also, in order to improve the accuracy of the oscillation frequency, a thorough study of oscillation matching evaluation, etc., should be carried out when deciding the circuit constants.

Table 19.1 (1) Damping Resistance Value

Damping Resistance Value	Frequency f (MHz)							
	2	$2 < f \leq 4$	$4 < f \leq 8$	$8 < f \leq 10$	$10 < f \leq 13$	$13 < f \leq 16$	$16 < f \leq 18$	$18 < f \leq 25$
R_d (Ω)	1 k	500	200	0	0	0	0	0

Note: A crystal resonator between 2 MHz and 25 MHz can be used. If the chip is to be operated at less than 2 MHz, the on-chip frequency divider should be used. (A crystal resonator of less than 2 MHz cannot be used.)

Table 19.1 (2) External Capacitance Values

External Capacitance Value	5 V Version	
Frequency f (MHz)	$20 < f \leq 25$	$2 \leq f \leq 20$
$C_{L1} = C_{L2}$ (pF)	10	10 to 22

Crystal Resonator: Figure 19.3 shows an equivalent circuit of the crystal resonator. The crystal resonator should have the characteristics listed in table 19.2.

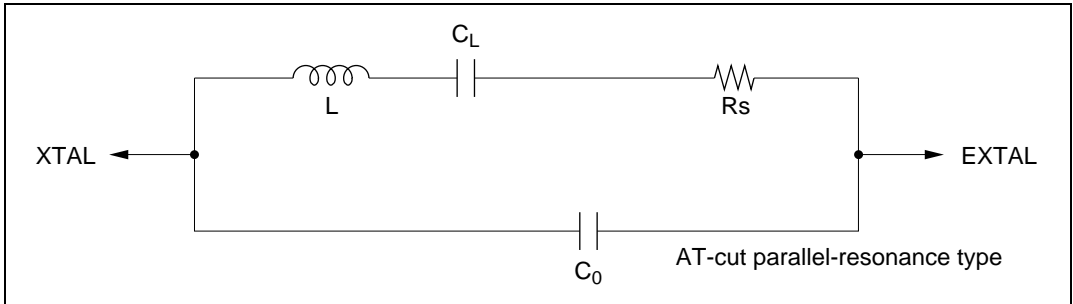
**Figure 19.3 Crystal Resonator Equivalent Circuit****Table 19.2 Crystal Resonator Parameters**

Frequency (MHz)	2	4	8	10	12	16	18	20	25
R_s max (Ω)	500	120	80	70	60	50	40	40	40
C_o (pF)	7 pF max	7 pF max	7 pF max	7 pF max	7 pF max	7 pF max	7 pF max	7 pF max	7 pF max

Use a crystal resonator with a frequency equal to the system clock frequency (ϕ).

Notes on Board Design: When a crystal resonator is connected, the following points should be noted:

Other signal lines should be routed away from the oscillator circuit to prevent induction from interfering with correct oscillation. See figure 19.4.

When the board is designed, the crystal resonator and its load capacitors should be placed as close as possible to the XTAL and EXTAL pins.

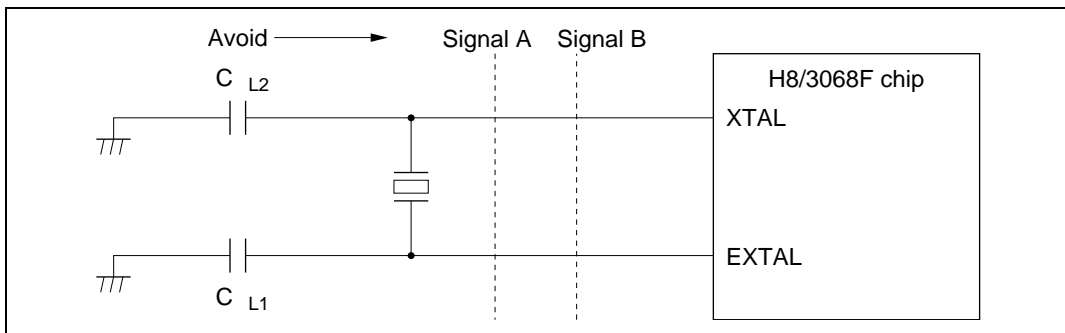

Figure 19.4 Oscillator Circuit Block Board Design Precautions

19.2.2 External Clock Input

Circuit Configuration: An external clock signal can be input as shown in the examples in figure 19.5. If the XTAL pin is left open, the stray capacitance should not exceed 10 pF. If the stray capacitance at the XTAL pin exceeds 10 pF in configuration a, use the connection shown in configuration b instead, and hold the external clock high in standby mode.

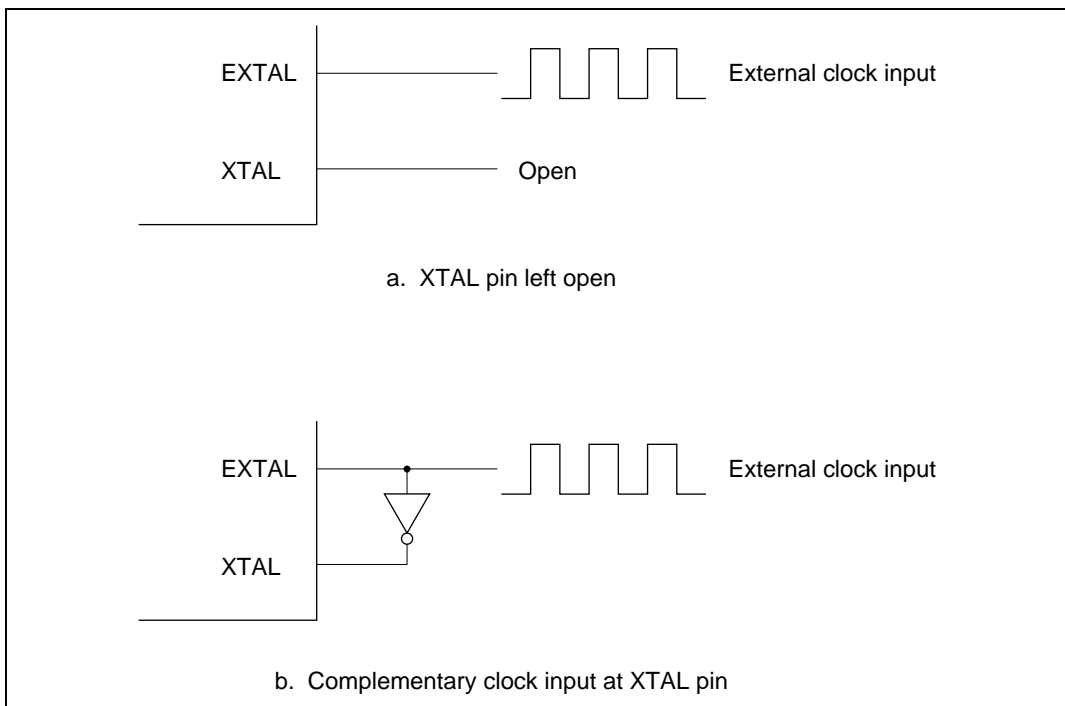

Figure 19.5 External Clock Input (Examples)

External Clock: The external clock frequency should be equal to the system clock frequency when not divided by the on-chip frequency divider. Table 19.3 shows the clock timing, figure 19.6 shows the external clock input timing, and figure 19.7 shows the external clock output settling delay timing. When the appropriate external clock is input via the EXTAL pin, its waveform is corrected by the on-chip oscillator and duty adjustment circuit.

When the appropriate external clock is input via the EXTAL pin, its waveform is corrected by the on-chip oscillator and duty adjustment circuit. The resulting stable clock is output to external devices after the external clock settling time (t_{DEXT}) has passed after the clock input. The system must remain reset with the reset signal low during t_{DEXT} , while the clock output is unstable.

Table 19.3 Clock Timing

Item	Symbol	$V_{\text{CC}} = 5.0 \text{ V} \pm 10\%$			Unit	Test Conditions
		Min	Max			
External clock input low pulse width	t_{EXL}	15	—	ns		Figure 19.6
External clock input high pulse width	t_{EXH}	15	—	ns		
External clock rise time	t_{EXr}	—	5	ns		
External clock fall time	t_{EXf}	—	5	ns		
Clock low pulse width	t_{CL}	0.4	0.6	t_{cyc}	$\phi \geq 5 \text{ MHz}$	Figure 19.17
		80	—	ns	$\phi < 5 \text{ MHz}$	
Clock high pulse width	t_{CH}	0.4	0.6	t_{cyc}	$\phi \geq 5 \text{ MHz}$	
		80	—	ns	$\phi < 5 \text{ MHz}$	
External clock output settling delay time	t_{DEXT}^*	500	—	μs		Figure 19.7

Note: * t_{DEXT} includes a $\overline{\text{RES}}$ pulse width (t_{RESW}). $t_{\text{RESW}} = 20 t_{\text{cyc}}$

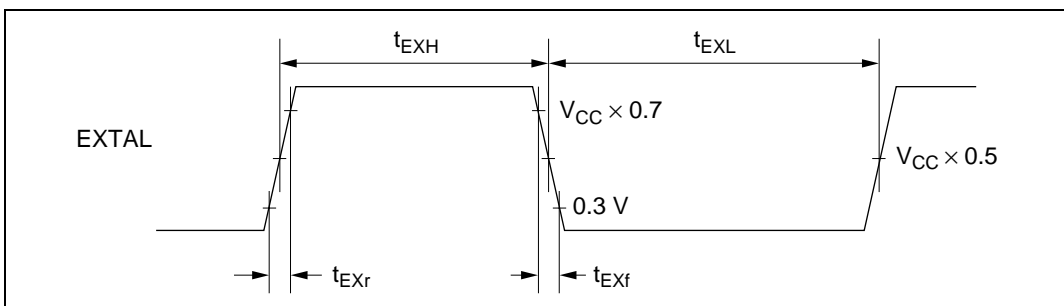

Figure 19.6 External Clock Input Timing

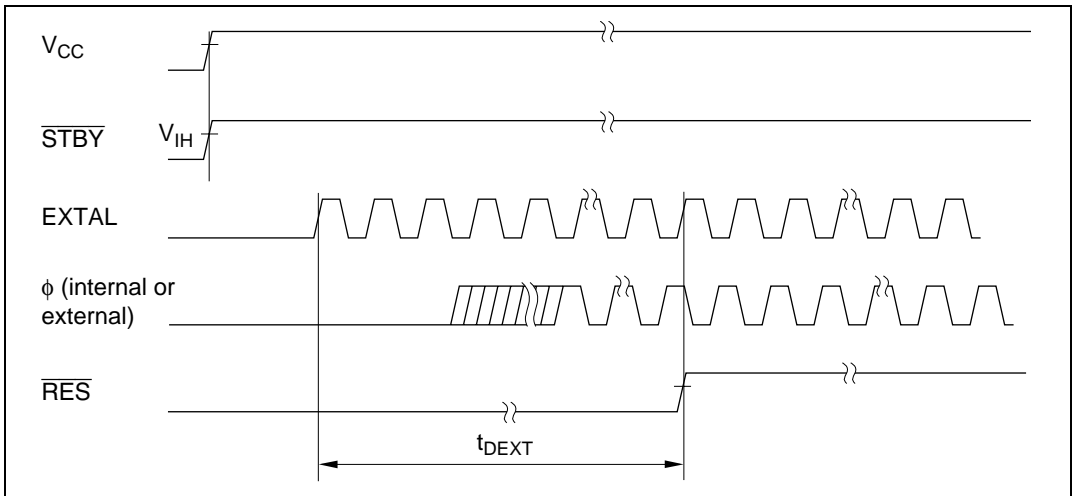

Figure 19.7 External Clock Output Settling Delay Timing

19.3 Duty Adjustment Circuit

When the oscillator frequency is 5 MHz or higher, the duty adjustment circuit adjusts the duty cycle of the clock signal from the oscillator to generate ϕ .

19.4 Prescalers

The prescalers divide the system clock (ϕ) to generate internal clocks ($\phi/2$ to $\phi/4096$).

19.5 Frequency Divider

The frequency divider divides the duty-adjusted clock signal to generate the system clock (ϕ). The frequency division ratio can be changed dynamically by modifying the value in DIVCR, as described below. Power consumption in the chip is reduced in almost direct proportion to the frequency division ratio. The system clock generated by the frequency divider can be output at the ϕ pin.

19.5.1 Register Configuration

Table 19.4 summarizes the frequency division register.

Table 19.4 Frequency Division Register

Address*	Name	Abbreviation	R/W	Initial Value
H'EE01B	Division control register	DIVCR	R/W	H'FC

Note: * Lower 20 bits of the address in advanced mode.

19.5.2 Division Control Register (DIVCR)

DIVCR is an 8-bit readable/writable register that selects the division ratio of the frequency divider.

Bit	7	6	5	4	3	2	1	0
	—	—	—	—	—	—	DIV1	DIV0
Initial value	1	1	1	1	1	1	0	0
Read/Write	—	—	—	—	—	—	R/W	R/W

Reserved bits

Divide bits 1 and 0
These bits select the frequency division ratio

DIVCR is initialized to H'FC by a reset and in hardware standby mode. It is not initialized in software standby mode.

Bits 7 to 2—Reserved: These bits cannot be modified and are always read as 1.

Bits 1 and 0—Divide (DIV1, DIV0): These bits select the frequency division ratio, as follows.

Bit 1 DIV1	Bit 0 DIV0	Frequency Division Ratio	
0	0	1/1	(Initial value)
0	1	1/2	
1	0	1/4	
1	1	1/8	

19.5.3 Usage Notes

The DIVCR setting changes the ϕ frequency, so note the following points.

- Select a frequency division ratio that stays within the assured operation range specified for the clock cycle time t_{cyc} in the AC electrical characteristics. Note that ϕ_{min} = lower limit of the operating frequency range. Ensure that ϕ is not below this lower limit.
- All on-chip module operations are based on ϕ . Note that the timing of timer operations, serial communication, and other time-dependent processing differs before and after any change in the division ratio. The waiting time for exit from software standby mode also changes when the division ratio is changed. For details, see section 20.4.3, Selection of Waiting Time for Exit from Software Standby Mode.

Section 20 Power-Down State

20.1 Overview

The H8/3068F has a power-down state that greatly reduces power consumption by halting the CPU, and a module standby function that reduces power consumption by selectively halting on-chip modules.

The power-down state includes the following three modes:

- Sleep mode
- Software standby mode
- Hardware standby mode

The module standby function can halt on-chip supporting modules independently of the power-down state. The modules that can be halted are the 16-bit timer, 8-bit timer, SCI0, SCI1, SCI2, DMAC, DRAM interface, and A/D converter.

Table 20.1 indicates the methods of entering and exiting the power-down modes and module standby mode, and gives the status of the CPU and on-chip supporting modules in each mode.

Table 20.1 Power-Down State and Module Standby Function

Mode	State											Exiting Conditions			
	Entering Conditions	Clock	CPU Register	DMAC	DRAM Interface	16-Bit Timer	8-Bit Timer	SC10	SC11	SC12	A/D		Other Modules RAM	ϕ clock output ⁴	I/O Ports
Sleep mode	SLEEP instruction executed while SSBY = 0 in SYSCR	Active	Halted ⁵	Active	Active	Active	Active	Active	Active	Active	Active	Active	Held	Held	<ul style="list-style-type: none"> Interrupt RES STBY
Software standby mode	SLEEP instruction executed while SSBY = 1 in SYSCR	Halted	Halted	Halted	Halted	Halted	Halted	Halted	Halted	Halted	Halted	Halted	Held	Held	<ul style="list-style-type: none"> NMI IRQ₀ to IRQ₂ RES STBY
Hardware standby mode	Low input at $\overline{\text{STBY}}$ pin	Halted	Halted	Halted	Halted	Halted	Halted	Halted	Halted	Halted	Halted	Halted	High impedance	High impedance	<ul style="list-style-type: none"> STBY RES Clear MSTR bit to 0⁵
Module standby	Corresponding bit set to 1 in MSTR	Active	Active	Halted ²	Halted ²	Halted ²	Halted ²	Halted ²	Halted ²	Halted ²	Halted ²	Halted ²	Active	—	<ul style="list-style-type: none"> STBY RES Clear MSTR bit to 0⁵

Notes: 1. RTCNT and bits 7 and 6 of RTMCSR are initialized. Other bits and registers hold their previous states.

2. State in which the corresponding MSTR bit was set to 1. For details see section 20.2.2, Module Standby Control Register H (MSTRH) and section 20.2.3, Module Standby Control Register L (MSTRL).

3. The RAME bit must be cleared to 0 in SYSCR before the transition from the program execution state to hardware standby mode.

4. When P6₇ is used as the ϕ output pin.

5. When a MSTR bit is set to 1, the registers of the corresponding on-chip supporting module are initialized. To restart the module, first clear the MSTR bit to 0, then set up the module registers again.

Legend

SYSCR: System control register

SSBY: Software standby bit

MSTRH: Module standby control register H

MSTRL: Module standby control register L

20.2 Register Configuration

The H8/3068F has a system control register (SYSCR) that controls the power-down state, and module standby control registers H (MSTCRH) and L (MSTCRL) that control the module standby function. Table 20.2 summarizes these registers.

Table 20.2 Control Register

Address*	Name	Abbreviation	R/W	Initial Value
H'EE012	System control register	SYSCR	R/W	H'09
H'EE01C	Module standby control register H	MSTCRH	R/W	H'78
H'EE01D	Module standby control register L	MSTCRL	R/W	H'00

Note: * Lower 20 bits of the address in advanced mode.

20.2.1 System Control Register (SYSCR)

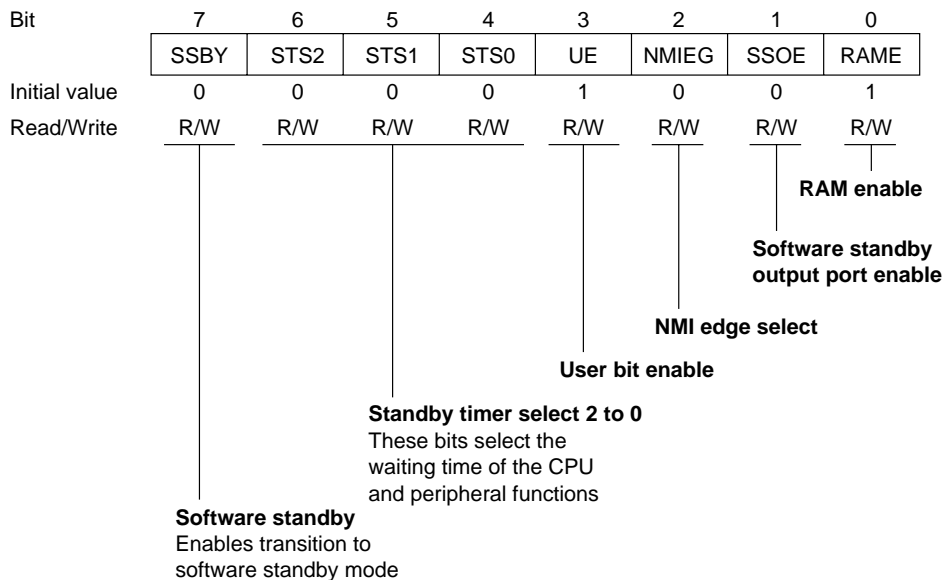

SYSCR is an 8-bit readable/writable register. Bit 7 (SSBY), bits 6 to 4 (STS2 to STS0), and bit 1 (SSOE) control the power-down state. For information on the other SYSCR bits, see section 3.3, System Control Register (SYSCR).

Bit 7—Software Standby (SSBY): Enables transition to software standby mode. When software standby mode is exited by an external interrupt, this bit remains set to 1 after the return to normal operation. To clear this bit, write 0.

Bit 7**SSBY****Description**

0	SLEEP instruction causes transition to sleep mode	(Initial value)
1	SLEEP instruction causes transition to software standby mode	

Bits 6 to 4—Standby Timer Select (STS2 to STS0): These bits select the length of time the CPU and on-chip supporting modules wait for the clock to settle when software standby mode is exited by an external interrupt. If the clock is generated by a crystal resonator, set these bits according to the clock frequency so that the waiting time will be at least 7 ms (oscillation settling time). See table 20.3. If an external clock is used, set these bits so that the waiting time will be at least 100 μ s.

Bit 6**STS2****Bit 5****STS1****Bit 4****STS0****Description**

0	0	0	Waiting time = 8,192 states	(Initial value)
		1	Waiting time = 16,384 states	
	1	0	Waiting time = 32,768 states	
		1	Waiting time = 65,536 states	
1	0	0	Waiting time = 131,072 states	
		1	Waiting time = 262,144 states	
		1	Illegal setting	

Bit 1—Software Standby Output Port Enable (SSOE): Specifies whether the address bus and bus control signals (\overline{CS}_0 to \overline{CS}_7 , \overline{AS} , \overline{RD} , \overline{HWR} , \overline{LWR} , \overline{UCAS} , \overline{LCAS} , and \overline{RFSH}) are kept as outputs or fixed high, or placed in the high-impedance state in software standby mode.

Bit 1**SSOE****Description**

0	In software standby mode, the address bus and bus control signals are all high-impedance	(Initial value)
1	In software standby mode, the address bus retains its output state and bus control signals are fixed high	

20.2.2 Module Standby Control Register H (MSTCRH)

MSTCRH is an 8-bit readable/writable register that controls output of the system clock (ϕ). It also controls the module standby function, which places individual on-chip supporting modules in the standby state. Module standby can be designated for the SCI0, SCI1, SCI2.

Bit	7	6	5	4	3	2	1	0
	PSTOP	—	—	—	—	MSTPH2	MSTPH1	MSTPH0
Initial value	0	1	1	1	1	0	0	0
Read/Write	R/W	—	—	—	—	R/W	R/W	R/W

Reserved bit

ϕ clock stop
Enables or disables
output of the system clock

Module standby H2 to 0
These bits select modules
to be placed in standby

MSTCRH is initialized to H'78 by a reset and in hardware standby mode. It is not initialized in software standby mode.

Bit 7— ϕ Clock Stop (PSTOP): Enables or disables output of the system clock (ϕ).

Bit 1

PSTOP

Description

0	System clock output is enabled	(Initial value)
1	System clock output is disabled	

Bits 6 to 3—Reserved: These bits cannot be modified and are always read as 1.

Bit 2—Module Standby H2 (MSTPH2): Selects whether to place the SCI2 in standby.

Bit 2

MSTPH2

Description

0	SCI2 operates normally	(Initial value)
1	SCI2 is in standby state	

Bit 1—Module Standby H1 (MSTPH1): Selects whether to place the SCI1 in standby.

Bit 1**MSTPH1 Description**

0	SCI1 operates normally	(Initial value)
1	SCI1 is in standby state	

Bit 0—Module Standby H0 (MSTPH0): Selects whether to place the SCI0 in standby.

Bit 0**MSTPH0 Description**

0	SCI0 operates normally	(Initial value)
1	SCI0 is in standby state	

20.2.3 Module Standby Control Register L (MSTCRL)

MSTCRL is an 8-bit readable/writable register that controls the module standby function, which places individual on-chip supporting modules in the standby state. Module standby can be designated for the DMAC, 16-bit timer, DRAM interface, 8-bit timer, and A/D converter modules.

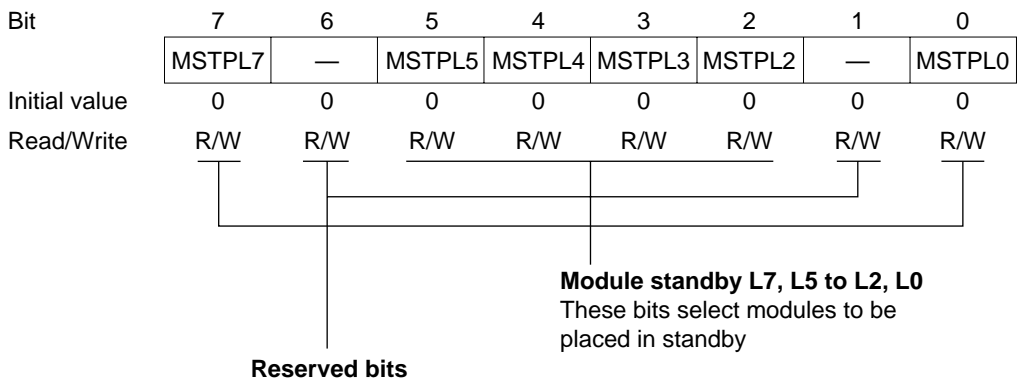

MSTCRL is initialized to H'00 by a reset and in hardware standby mode. It is not initialized in software standby mode.

Bit 7—Module Standby L7 (MSTPL7): Selects whether to place the DMAC in standby.

Bit 7

MSTPL7	Description	
0	DMAC operates normally	(Initial value)
1	DMAC is in standby state	

Bit 6—Reserved: This bit can be written and read.

Bit 5—Module Standby L5 (MSTPL5): Selects whether to place the DRAM interface in standby.

Bit 5

MSTPL5	Description	
0	DRAM interface operates normally	(Initial value)
1	DRAM interface is in standby state	

Bit 4—Module Standby L4 (MSTPL4): Selects whether to place the 16-bit timer in standby.

Bit 4

MSTPL4	Description	
0	16-bit timer operates normally	(Initial value)
1	16-bit timer is in standby state	

Bit 3—Module Standby L3 (MSTPL3): Selects whether to place 8-bit timer channels 0 and 1 in standby.

Bit 3

MSTPL3	Description	
0	8-bit timer channels 0 and 1 operate normally	(Initial value)
1	8-bit timer channels 0 and 1 are in standby state	

Bit 2—Module Standby L2 (MSTPL2): Selects whether to place 8-bit timer channels 2 and 3 in standby.

Bit 2**MSTPL2 Description**

0	8-bit timer channels 2 and 3 operate normally	(Initial value)
1	8-bit timer channels 2 and 3 are in standby state	

Bit 1—Reserved: This bit can be written and read.

Bit 0—Module Standby L0 (MSTPL0): Selects whether to place the A/D converter in standby.

Bit 0**MSTPL0 Description**

0	A/D converter operates normally	(Initial value)
1	A/D converter is in standby state	

20.3 Sleep Mode

20.3.1 Transition to Sleep Mode

When the SSBY bit is cleared to 0 in SYSCR, execution of the SLEEP instruction causes a transition from the program execution state to sleep mode. Immediately after executing the SLEEP instruction the CPU halts, but the contents of its internal registers are retained. The DMA controller (DMAC), DRAM interface, and on-chip supporting modules do not halt in sleep mode. Modules which have been placed in standby by the module standby function, however, remain halted.

20.3.2 Exit from Sleep Mode

Sleep mode is exited by an interrupt, or by input at the $\overline{\text{RES}}$ or $\overline{\text{STBY}}$ pin.

Exit by Interrupt: An interrupt terminates sleep mode and causes a transition to the interrupt exception handling state. Sleep mode is not exited by an interrupt source in an on-chip supporting module if the interrupt is disabled in the on-chip supporting module. Sleep mode is not exited by an interrupt other than NMI if the interrupt is masked by interrupt priority settings and the settings of the I and UI bits in CCR, IPR.

Exit by $\overline{\text{RES}}$ Input: Low input at the $\overline{\text{RES}}$ pin exits from sleep mode to the reset state.

Exit by $\overline{\text{STBY}}$ Input: Low input at the $\overline{\text{STBY}}$ pin exits from sleep mode to hardware standby mode.

20.4 Software Standby Mode

20.4.1 Transition to Software Standby Mode

To enter software standby mode, execute the SLEEP instruction while the SSBY bit is set to 1 in SYSCR.

In software standby mode, current dissipation is reduced to an extremely low level because the CPU, clock, and on-chip supporting modules all halt. The DMAC and on-chip supporting modules are reset and halted. As long as the specified voltage is supplied, however, CPU register contents and on-chip RAM data are retained. The settings of the I/O ports and DRAM interface* are also held. When the WDT is used as a watchdog timer ($WT/\overline{IT} = 1$), the TME bit must be cleared to 0 before setting SSBY. Also, when setting TME to 1, SSBY should be cleared to 0.

Clear the BRLE bit in BRCCR (inhibiting bus release) before making a transition to software standby mode.

Note: * RTCNT and bits 7 and 6 of RTMCSR are initialized. Other bits and registers hold their previous states.

20.4.2 Exit from Software Standby Mode

Software standby mode can be exited by input of an external interrupt at the NMI, $\overline{IRQ_0}$, $\overline{IRQ_1}$, or $\overline{IRQ_2}$ pin, or by input at the \overline{RES} or \overline{STBY} pin.

Exit by Interrupt: When an NMI, IRQ_0 , IRQ_1 , or IRQ_2 interrupt request signal is received, the clock oscillator begins operating. After the oscillator settling time selected by bits STS2 to STS0 in SYSCR, stable clock signals are supplied to the entire chip, software standby mode ends, and interrupt exception handling begins. Software standby mode is not exited if the interrupt enable bits of interrupts IRQ_0 , IRQ_1 , and IRQ_2 are cleared to 0, or if these interrupts are masked in the CPU.

Exit by \overline{RES} Input: When the \overline{RES} input goes low, the clock oscillator starts and clock pulses are supplied immediately to the entire chip. The \overline{RES} signal must be held low long enough for the clock oscillator to stabilize. When \overline{RES} goes high, the CPU starts reset exception handling.

Exit by \overline{STBY} Input: Low input at the \overline{STBY} pin causes a transition to hardware standby mode.

20.4.3 Selection of Waiting Time for Exit from Software Standby Mode

Bits STS2 to STS0 in SYSCR and bits DIV1 and DIV0 in DIVCR should be set as follows.

Crystal Resonator: Set STS2 to STS0, DIV1, and DIV0 so that the waiting time (for the clock to stabilize) is at least 7 ms. Table 20.3 indicates the waiting times that are selected by STS2 to STS0, DIV1, and DIV0 settings at various system clock frequencies.

External Clock: Set STS2 to STS0, DIV1, and DIV0 so that the waiting time is at least 100 μ s.

Table 20.3 Clock Frequency and Waiting Time for Clock to Settle

DIV1	DIV0	STS2	STS1	STS0	Waiting Time	25 MHz	20 MHz	18 MHz	16 MHz	12 MHz	10 MHz	8 MHz	6 MHz	4 MHz	2 MHz	1 MHz	Unit
0	0	0	0	0	8192 states	0.3	0.4	0.46	0.51	0.65	0.8	1.0	1.3	2.0	4.1	8.2*	ms
		0	0	1	16384 states	0.7	0.8	0.91	1.0	1.3	1.6	2.0	2.7	4.1	8.2*	16.4	
		0	1	0	32768 states	1.3	1.6	1.8	2.0	2.7	3.3	4.1	5.5	8.2*	16.4	32.8	
		0	1	1	65536 states	2.6	3.3	3.6	4.1	5.5	6.6	8.2*	10.9*	16.4	32.8	65.5	
		1	0	0	131072 states	5.2	6.6	7.3*	8.2*	10.9*	13.1*	16.4	21.8	32.8	65.5	131.1	
		1	0	1	262144 states	10.5*	13.1*	14.6	16.4	21.8	26.2	32.8	43.7	65.5	131.1	262.1	
		1	1	0	1024 states	0.04	0.05	0.057	0.064	0.085	0.10	0.13	0.17	0.26	0.51	1.0	
		1	1	1		Illegal setting											
0	1	0	0	0	8192 states	0.7	0.8	0.91	1.02	1.4	1.6	2.0	2.7	4.1	8.2*	16.4*	ms
		0	0	1	16384 states	1.3	1.6	1.8	2.0	2.7	3.3	4.1	5.5	8.2*	16.4	32.8	
		0	1	0	32768 states	2.6	3.3	3.6	4.1	5.5	6.6	8.2*	10.9*	16.4	32.8	65.5	
		0	1	1	65536 states	5.2	6.6	7.3*	8.2*	10.9*	13.1*	16.4	21.8	32.8	65.5	131.1	
		1	0	0	131072 states	10.5*	13.1*	14.6	16.4	21.8	26.2	32.8	43.7	65.5	131.1	262.1	
		1	0	1	262144 states	21.0	26.2	29.1	32.8	43.7	52.4	65.5	87.4	131.1	262.1	524.3	
		1	1	0	1024 states	0.08	0.10	0.11	0.13	0.17	0.20	0.26	0.34	0.51	1.0	2.0	
		1	1	1		Illegal setting											
1	0	0	0	0	8192 states	1.3	1.6	1.8	2.0	2.7	3.3	4.1	5.5	8.2*	16.4*	32.8*	ms
		0	0	1	16384 states	2.6	3.3	3.6	4.1	5.5	6.6	8.2*	10.9*	16.4	32.8	65.5	
		0	1	0	32768 states	5.2	6.6	7.3*	8.2*	10.9*	13.1*	16.4	21.8	32.8	65.5	131.1	
		0	1	1	65536 states	10.5*	13.1*	14.6	16.4	21.8	26.2	32.8	43.7	65.5	131.1	262.1	
		1	0	0	131072 states	21.0	26.2	29.1	32.8	43.7	52.4	65.5	87.4	131.1	262.1	524.3	
		1	0	1	262144 states	41.9	52.4	58.3	65.5	87.4	104.9	131.1	174.8	262.1	524.3	1048.6	
		1	1	0	1024 states	0.16	0.20	0.23	0.26	0.34	0.41	0.51	0.68	1.02	2.0	4.1	
		1	1	1		Illegal setting											
1	1	0	0	0	8192 states	2.6	3.3	3.6	4.1	5.5	6.6	8.2*	10.9*	16.4*	32.8*	65.5	ms
		0	0	1	16384 states	5.2	6.6	7.3*	8.2*	10.9*	13.1*	16.4	21.8	32.8	65.5	131.1	
		0	1	0	32768 states	10.5	13.1*	14.6	16.4	21.8	26.2	32.8	43.7	65.5	131.1	262.1	
		0	1	1	65536 states	21.0*	26.2	29.1	32.8	43.7	52.4	65.5	87.4	131.1	262.1	524.3	
		1	0	0	131072 states	41.9	52.4	58.3	65.5	87.4	104.9	131.1	174.8	262.1	524.3	1048.6	
		1	0	1	262144 states	83.9	104.9	116.5	131.1	174.8	209.7	262.1	349.5	524.3	1048.6	2097.1	
		1	1	0	1024 states	0.33	0.41	0.46	0.51	0.68	0.82	1.0	1.4	2.0	4.1	8.2*	
		1	1	1		Illegal setting											

*: Recommended setting

20.4.4 Sample Application of Software Standby Mode

Figure 20.1 shows an example in which software standby mode is entered at the fall of NMI and exited at the rise of NMI.

With the NMI edge select bit (NMIEG) cleared to 0 in SYSCR (selecting the falling edge), an NMI interrupt occurs. Next the NMIEG bit is set to 1 (selecting the rising edge) and the SSBY bit is set to 1; then the SLEEP instruction is executed to enter software standby mode.

Software standby mode is exited at the next rising edge of the NMI signal.

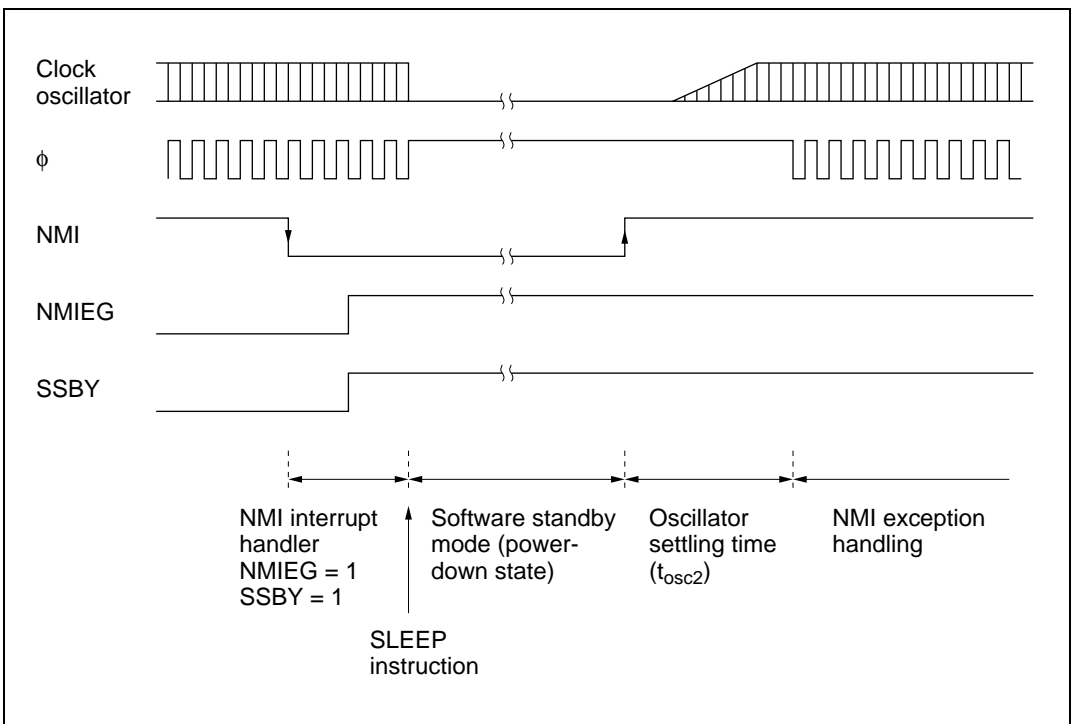

Figure 20.1 NMI Timing for Software Standby Mode (Example)

20.4.5 Note

The I/O ports retain their existing states in software standby mode. If a port is in the high output state, its output current is not reduced.

20.5 Hardware Standby Mode

20.5.1 Transition to Hardware Standby Mode

Regardless of its current state, the chip enters hardware standby mode whenever the \overline{STBY} pin goes low. Hardware standby mode reduces power consumption drastically by halting all functions of the CPU, DMAC, DRAM interface, and on-chip supporting modules. All modules are reset except the on-chip RAM. As long as the specified voltage is supplied, on-chip RAM data is retained. I/O ports are placed in the high-impedance state.

Clear the RAME bit to 0 in SYSCR before \overline{STBY} goes low to retain on-chip RAM data.

The inputs at the mode pins (MD2 to MD0) should not be changed during hardware standby mode.

20.5.2 Exit from Hardware Standby Mode

Hardware standby mode is exited by inputs at the \overline{STBY} and \overline{RES} pins. While \overline{RES} is low, when \overline{STBY} goes high, the clock oscillator starts running. \overline{RES} should be held low long enough for the clock oscillator to settle. When \overline{RES} goes high, reset exception handling begins, followed by a transition to the program execution state.

20.5.3 Timing for Hardware Standby Mode

Figure 20.2 shows the timing relationships for hardware standby mode. To enter hardware standby mode, first drive \overline{RES} low, then drive \overline{STBY} low. To exit hardware standby mode, first drive \overline{STBY} high, wait for the clock to settle, then bring \overline{RES} from low to high.

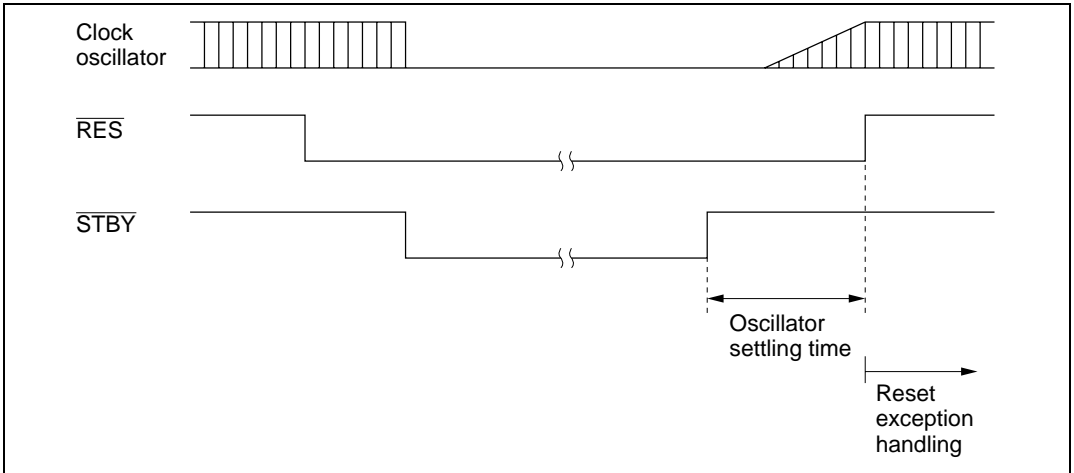

Figure 20.2 Hardware Standby Mode Timing

20.6 Module Standby Function

20.6.1 Module Standby Timing

The module standby function can halt several of the on-chip supporting modules (SCI2, SCI1, SCI0, the DMAC, 16-bit timer, 8-bit timer, DRAM interface, and A/D converter) independently in the power-down state. This standby function is controlled by bits MSTPH2 to MSTPH0 in MSTCRH and bits MSTPL7 to MSTPL0 in MSTCRL. When one of these bits is set to 1, the corresponding on-chip supporting module is placed in standby and halts at the beginning of the next bus cycle after the MSTCR write cycle.

20.6.2 Read/Write in Module Standby

When an on-chip supporting module is in module standby, read/write access to its registers is disabled. Read access always results in H'FF data. Write access is ignored.

20.6.3 Usage Notes

When using the module standby function, note the following points.

DMAC: When setting a bit in MSTCR to 1 to place the DMAC in module standby, make sure that the DMAC is not currently requesting the bus right. If the corresponding bit in MSTCR is set to 1 when a bus request is present, operation of the bus arbiter becomes ambiguous and a malfunction may occur.

DRAM Interface: When the module standby function is used on the DRAM interface, set the MSTCR bit to 1 while DRAM space is deselected.

On-Chip Supporting Module Interrupts: Before setting a module standby bit, first disable interrupts by that module. When an on-chip supporting module is placed in standby by the module standby function, its registers are initialized, including registers with interrupt request flags.

Pin States: Pins used by an on-chip supporting module lose their module functions when the module is placed in module standby. What happens after that depends on the particular pin. For details, see section 8, I/O Ports. Pins that change from the input to the output state require special care. For example, if SCI1 is placed in module standby, the receive data pin loses its receive data function and becomes a port pin. If its port DDR bit is set to 1, the pin becomes a data output pin, and its output may collide with external SCI transmit data. Data collision should be prevented by clearing the port DDR bit to 0 or taking other appropriate action.

Register Resetting: When an on-chip supporting module is halted by the module standby function, all its registers are initialized. To restart the module, after its MSTCR bit is cleared to 0,

its registers must be set up again. It is not possible to write to the registers while the MSTCR bit is set to 1.

MSTCR Access from DMAC Disabled: To prevent malfunctions, MSTCR can only be accessed from the CPU. It can be read by the DMAC, but it cannot be written by the DMAC.

20.7 System Clock Output Disabling Function

Output of the system clock (ϕ) can be controlled by the PSTOP bit in MSTCRH. When the PSTOP bit is set to 1, output of the system clock halts and the ϕ pin is placed in the high-impedance state. Figure 20.3 shows the timing of the stopping and starting of system clock output. When the PSTOP bit is cleared to 0, output of the system clock is enabled. Table 20.4 indicates the state of the ϕ pin in various operating states.

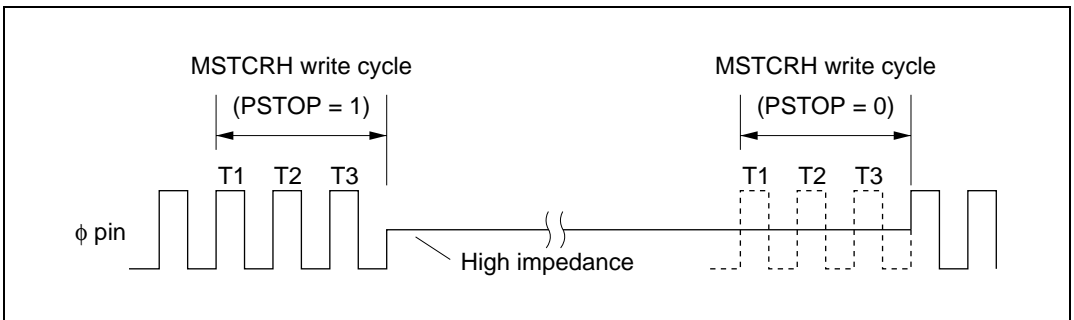

Figure 20.3 Starting and Stopping of System Clock Output

Table 20.4 ϕ Pin State in Various Operating States

Operating State	PSTOP = 0	PSTOP = 1
Hardware standby	High impedance	High impedance
Software standby	Always high	High impedance
Sleep mode	System clock output	High impedance
Normal operation	System clock output	High impedance

Section 21 Electrical Characteristics

21.1 Electrical Characteristics of H8/3068F-ZTAT

21.1.1 Absolute Maximum Ratings

Table 21.1 lists the absolute maximum ratings.

Table 21.1 Absolute Maximum Ratings

Item	Symbol	Value	Unit
Power supply voltage	V_{CC}^{*1}	-0.3 to +7.0	V
Input voltage (FWE) ^{*2}	V_{in}	-0.3 to $V_{CC} + 0.3$	V
Input voltage (except for port 7) ^{*2}	V_{in}	-0.3 to $V_{CC} + 0.3$	V
Input voltage (port 7)	V_{in}	-0.3 to $AV_{CC} + 0.3$	V
Reference voltage	V_{REF}	-0.3 to $AV_{CC} + 0.3$	V
Analog power supply voltage	AV_{CC}	-0.3 to +7.0	V
Analog input voltage	V_{AN}	-0.3 to $AV_{CC} + 0.3$	V
Operating temperature	T_{opr}	-20 to +75 ^{*3}	°C
Storage temperature	T_{stg}	-55 to +125	°C

Caution: Permanent damage to the chip may result if absolute maximum ratings are exceeded.

- Notes:
1. Do not apply the power supply voltage to the V_{CL} pin. Connect an external capacitor between this pin and GND.
 2. 12 V must not be applied to any pin, as this may cause permanent damage to the device.
 3. The operating temperature range for flash memory programming/erasing is 0°C to +75°C.

21.1.2 DC Characteristics

Table 21.2 lists the DC characteristics. Table 21.3 lists the permissible output currents.

Table 21.2 DC Characteristics (1)

Conditions: $V_{CC} = 5.0 \text{ V} \pm 10\%$, $AV_{CC} = 5.0 \text{ V} \pm 10\%$, $V_{REF} = 4.5 \text{ V}$ to AV_{CC}^{*1} ,
 $V_{SS} = AV_{SS} = 0 \text{ V}^{*1}$, $T_a = -20^\circ\text{C}$ to $+75^\circ\text{C}$
 [Programming/erasing conditions: $T_a = 0^\circ\text{C}$ to $+75^\circ\text{C}$]

Item		Symbol	Min	Typ	Max	Unit	Test Conditions
Schmitt trigger input voltages	Port A, P8 ₀ to P8 ₂	V_T^-	1.0	—	—	V	
		V_T^+	—	—	$V_{CC} \times 0.7$	V	
		$V_T^+ - V_T^-$	0.4	—	—	V	
Input high voltage	STBY, RES, NMI, MD ₂ to MD ₀ , FWE	V_{IH}	$V_{CC} - 0.7$	—	$V_{CC} + 0.3$	V	
	EXTAL		$V_{CC} \times 0.7$	—	$V_{CC} + 0.3$	V	
	Port 7		2.0	—	$AV_{CC} + 0.3$	V	
	Ports 1 to 6, P8 ₃ , P8 ₄ , P9 ₀ to P9 ₅ , port B		2.0	—	$V_{CC} + 0.3$	V	
Input low voltage	STBY, RES, FWE, MD ₂ to MD ₀	V_{IL}	-0.3	—	0.5	V	
	NMI, EXTAL, ports 1 to 7, P8 ₃ , P8 ₄ , P9 ₀ to P9 ₅ , port B		-0.3	—	0.8	V	
Output high voltage	All output pins	V_{OH}	$V_{CC} - 0.5$	—	—	V	$I_{OH} = -200 \mu\text{A}$
			3.5	—	—	V	$I_{OH} = -1 \text{ mA}$
Output low voltage	All output pins	V_{OL}	—	—	0.4	V	$I_{OL} = 1.6 \text{ mA}$
			Ports 1, 2, and 5	—	—	1.0	V

Item	Symbol	Min	Typ	Max	Unit	Test Conditions		
Input leakage current	STBY, RES, NMI, FWE, MD ₂ to MD ₀	$ I_{in} $	—	—	1.0	μA	$V_{in} = 0.5\text{ V to }V_{CC} - 0.5\text{ V}$	
	Port 7	—	—	1.0	μA	$V_{in} = 0.5\text{ V to }AV_{CC} - 0.5\text{ V}$		
Three-state leakage current	Ports 1 to 6 Ports 8 to B	$ I_{TSI} $	—	—	1.0	μA	$V_{in} = 0.5\text{ V to }V_{CC} - 0.5\text{ V}$	
Input pull-up MOS current	Ports 2, 4, and 5	$-I_p$	50	—	300	μA	$V_{in} = 0\text{ V}$	
Input capacitance	FWE	C_{in}	—	—	80	pF	$V_{in} = 0\text{ V}$ $f = f_{min}$	
	NMI	—	—	—	50	pF	$T_a = 25^\circ\text{C}$	
	All input pins except NMI	—	—	—	15	pF		
Current dissipation* ²	Normal operation	I_{CC}^{*4}	—	32	47	mA	$f = 20\text{ MHz}$	
				(5.0 V)				$f = 25\text{ MHz}$
	Sleep mode	—	—	—	24	38	mA	$f = 20\text{ MHz}$
					(5.0 V)			
	Module standby mode	—	—	—	19	31	mA	$f = 20\text{ MHz}$
					(5.0 V)			
	Standby mode* ³	—	—	—	1.0	10	μA	$T_a \leq 50^\circ\text{C}$
					—	—		80
	Flash memory programming/erasing* ⁵	—	—	—	37	57	mA	$f = 20\text{ MHz}$
					42	68		$f = 25\text{ MHz}$

Item		Symbol	Min	Typ	Max	Unit	Test Conditions
Analog power supply current	During A/D conversion	I_{CC}	—	0.6	1.5	mA	
	During A/D and D/A conversion		—	0.6	1.5	mA	
	Idle		—	0.01	5	μ A	DASTE = 0
Reference current	During A/D conversion	I_{CC}	—	0.45	0.8	mA	
	During A/D and D/A conversion		—	2.0	3.0	mA	
	Idle		—	0.01	5	μ A	DASTE = 0
RAM standby voltage		V_{RAM}	2.0	—	—	V	

Notes: 1. If the A/D converter is not used, do not leave the AV_{CC} , V_{REF} , and AV_{SS} pins open. Connect AV_{CC} and V_{REF} to V_{CC} , and connect AV_{SS} to V_{SS} .

2. Current dissipation values are for $V_{IH\ min} = V_{CC} - 0.5\ V$ and $V_{IL\ max} = 0.5\ V$ with all output pins unloaded and the on-chip MOS pull-up transistors in the off state.

3. The values are for $V_{RAM} \leq V_{CC} < 4.5\ V$, $V_{IH\ min} = V_{CC} \times 0.9$, and $V_{IL\ max} = 0.3\ V$.

4. $I_{CC\ max. (normal\ operation)} = 3.0\ (mA) + 0.40\ (mA/(MHz \times V)) \times V_{CC} \times f$

$I_{CC\ max. (sleep\ mode)} = 3.0\ (mA) + 0.32\ (mA/(MHz \times V)) \times V_{CC} \times f$

$I_{CC\ max. (sleep\ mode + module\ standby\ mode)}$

$= 3.0\ (mA) + 0.25\ (mA/(MHz \times V)) \times V_{CC} \times f$

The Typ values for power consumption are reference values.

5. Sum of current dissipation in normal operation and current dissipation in program/erase operations.

Table 21.3 Permissible Output Currents

Conditions: $V_{CC} = 4.5\text{ V to }5.5\text{ V}$, $AV_{CC} = 4.5\text{ V to }5.5\text{ V}$, $V_{REF} = 4.5\text{ V to }AV_{CC}$,
 $V_{SS} = AV_{SS} = 0\text{ V}$, $T_a = -40^\circ\text{C to }+75^\circ\text{C}$

Item		Symbol	Min	Typ	Max	Unit
Permissible output low current (per pin)	Ports 1, 2, and 5	I_{OL}	—	—	10	mA
	Other output pins		—	—	2.0	mA
Permissible output low current (total)	Total of 20 pins in Ports 1, 2, and 5	ΣI_{OL}	—	—	80	mA
	Total of all output pins, including the above		—	—	120	mA
Permissible output high current (per pin)	All output pins	$ -I_{OH} $	—	—	2.0	mA
Permissible output high current (total)	Total of all output pins	$ \Sigma I_{OH} $	—	—	40	mA

- Notes: 1. To protect chip reliability, do not exceed the output current values in table 21.3.
 2. When directly driving a darlington pair or LED, always insert a current-limiting resistor in the output line, as shown in figures 21.1 and 21.2.

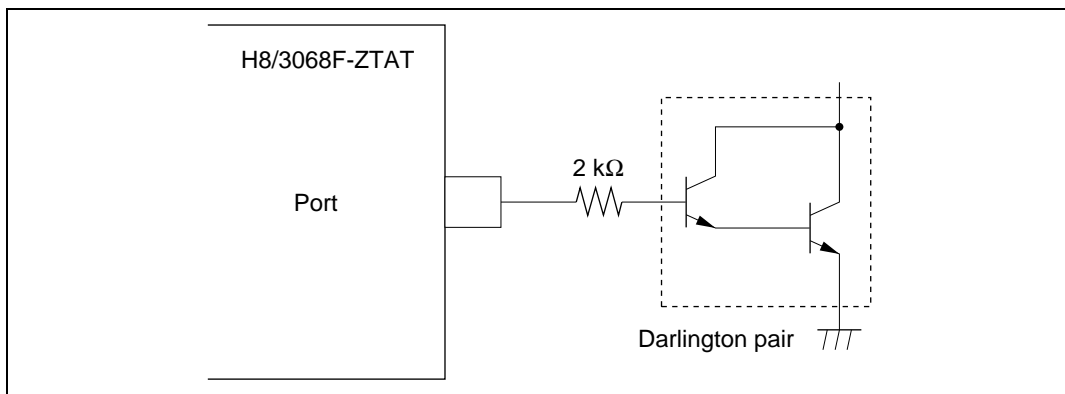
**Figure 21.1 Darlington Pair Drive Circuit (Example)**

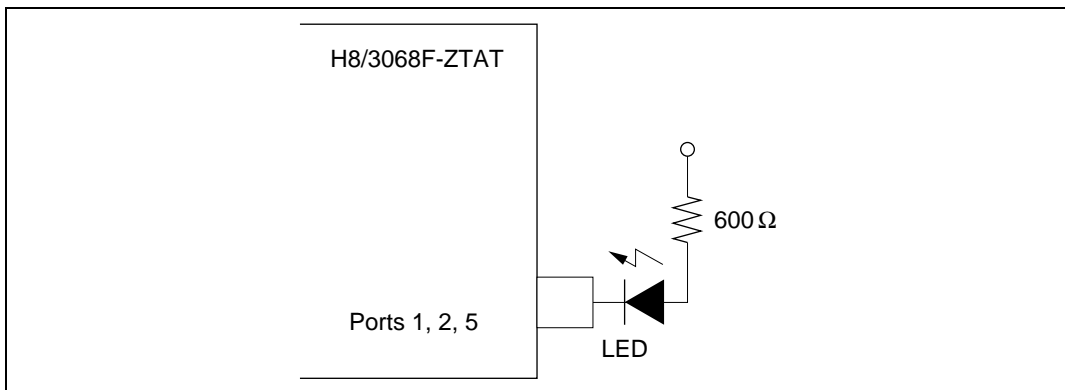

Figure 21.2 Sample LED Circuit

21.1.3 AC Characteristics

Clock timing parameters are listed in table 21.4, control signal timing parameters in table 21.5, and bus timing parameters in table 21.6. Timing parameters of the on-chip supporting modules are listed in table 21.7.

Table 21.4 Clock Timing

Condition: $T_a = -20^{\circ}\text{C}$ to $+75^{\circ}\text{C}$

Condition A: $V_{CC} = 5.0\text{ V} \pm 10\%$, $AV_{CC} = 5.0\text{ V} \pm 10\%$, $V_{REF} = 4.5$ to AV_{CC} , $V_{SS} = AV_{SS} = 0\text{ V}$, $f_{max} = 20\text{ MHz}$

Condition B: $V_{CC} = 5.0\text{ V} \pm 10\%$, $AV_{CC} = 5.0\text{ V} \pm 10\%$, $V_{REF} = 4.5$ to AV_{CC} , $V_{SS} = AV_{SS} = 0\text{ V}$, $f_{max} = 25\text{ MHz}$

Item	Symbol	Condition				Unit	Test Conditions
		A		B			
		Min	Max	Min	Max		
Clock cycle time	t_{cyc}	50	500	40	500	ns	Figure 21.4 to figure 21.6
Clock pulse low width	t_{CL}	15	—	10	—	ns	
Clock pulse high width	t_{CH}	15	—	10	—	ns	
Clock rise time	t_{Cr}	—	10	—	10	ns	
Clock fall time	t_{Cf}	—	10	—	10	ns	
Clock oscillator settling time at reset	t_{OSC1}	20	—	20	—	ms	Figure 21.4
Clock oscillator settling time in software standby	t_{OSC2}	7	—	7	—	ms	

Table 21.5 Control Signal TimingCondition: $T_a = -20^{\circ}\text{C}$ to $+75^{\circ}\text{C}$ Condition A: $V_{CC} = 5.0\text{ V} \pm 10\%$, $AV_{CC} = 5.0\text{ V} \pm 10\%$, $V_{REF} = 4.5$ to AV_{CC} , $V_{SS} = AV_{SS} = 0\text{ V}$,
 $f_{max} = 20\text{ MHz}$ Condition B: $V_{CC} = 5.0\text{ V} \pm 10\%$, $AV_{CC} = 5.0\text{ V} \pm 10\%$, $V_{REF} = 4.5$ to AV_{CC} , $V_{SS} = AV_{SS} = 0\text{ V}$,
 $f_{max} = 25\text{ MHz}$

Item	Symbol	Condition		Unit	Test Conditions
		A and B			
		Min	Max		
$\overline{\text{RES}}$ setup time	t_{RESS}	150	—	ns	Figure 21.5
$\overline{\text{RES}}$ pulse width	t_{RESW}	20	—	t_{cyc}	
Mode programming setup time	t_{MDS}	200	—	ns	
NMI, IRQ setup time	t_{NMIS}	150	—	ns	Figure 21.7
NMI, IRQ hold time	t_{NMIH}	10	—	ns	
NMI, IRQ pulse width	t_{NMIW}	200	—	ns	

Table 21.6 Bus TimingCondition: $T_a = -20^{\circ}\text{C}$ to $+75^{\circ}\text{C}$ Condition A: $V_{CC} = 5.0\text{ V} \pm 10\%$, $AV_{CC} = 5.0\text{ V} \pm 10\%$, $V_{REF} = 4.5$ to AV_{CC} , $V_{SS} = AV_{SS} = 0\text{ V}$,
 $f_{max} = 20\text{ MHz}$ Condition B: $V_{CC} = 5.0\text{ V} \pm 10\%$, $AV_{CC} = 5.0\text{ V} \pm 10\%$, $V_{REF} = 4.5$ to AV_{CC} , $V_{SS} = AV_{SS} = 0\text{ V}$,
 $f_{max} = 25\text{ MHz}$

Item	Symbol	Condition		Unit	Test Conditions
		A and B			
		Min	Max		
Address delay time	t_{AD}	—	25	ns	Figure 21.8, figure 21.9
Address hold time	t_{AH}	$0.5 t_{cyc} - 20$	—	ns	
Read strobe delay time	t_{RSD}	—	25	ns	
Address strobe delay time	t_{ASD}	—	25	ns	
Write strobe delay time	t_{WSD}	—	25	ns	
Strobe delay time	t_{SD}	—	25	ns	
Write strobe pulse width 1	t_{WSW1}	$1.0 t_{cyc} - 25$	—	ns	
Write strobe pulse width 2	t_{WSW2}	$1.5 t_{cyc} - 25$	—	ns	
Address setup time 1	t_{AS1}	$0.5 t_{cyc} - 20$	—	ns	
Address setup time 2	t_{AS2}	$1.0 t_{cyc} - 20$	—	ns	
Read data setup time	t_{RDS}	25	—	ns	
Read data hold time	t_{RDH}	0	—	ns	
Write data delay time	t_{WDD}	—	35	ns	
Write data setup time 1	t_{WDS1}	$1.0 t_{cyc} - 30$	—	ns	
Write data setup time 2	t_{WDS2}	$2.0 t_{cyc} - 30$	—	ns	
Write data hold time	t_{WDH}	$0.5 t_{cyc} - 15$	—	ns	
Read data access time 1	t_{ACC1}	—	$2.0 t_{cyc} - 45$	ns	Figure 21.17, figure 21.18
Read data access time 2	t_{ACC2}	—	$3.0 t_{cyc} - 45$	ns	
Read data access time 3	t_{ACC3}	—	$1.5 t_{cyc} - 45$	ns	
Read data access time 4	t_{ACC4}	—	$2.5 t_{cyc} - 45$	ns	
Precharge time 1	t_{PCH1}	$1.0 t_{cyc} - 20$	—	ns	
Precharge time 2	t_{PCH2}	$0.5 t_{cyc} - 20$	—	ns	

Item	Symbol	Condition		Unit	Test Conditions
		A and B			
		Min	Max		
Wait setup time	t_{WTS}	25	—	ns	Figure 21.19
Wait hold time	t_{WTH}	5	—	ns	
Bus request setup time	t_{BRQS}	25	—	ns	Figure 21.20
Bus acknowledge delay time 1	t_{BACD1}	—	30	ns	
Bus acknowledge delay time 2	t_{BACD2}	—	30	ns	
Bus-floating time	t_{BZD}	—	30	ns	
\overline{RAS} precharge time	t_{RP}	$1.5 t_{cyc} - 25$	—	ns	Figure 21.17 to figure 21.19
\overline{CAS} precharge time	t_{CP}	$0.5 t_{cyc} - 15$	—	ns	
Low address hold time	t_{RAH}	$0.5 t_{cyc} - 15$	—	ns	
\overline{RAS} delay time 1	t_{RAD1}	—	25	ns	
\overline{RAS} delay time 2	t_{RAD2}	—	30	ns	
\overline{CAS} delay time 1	t_{CASD1}	—	25	ns	
\overline{CAS} delay time 2	t_{CASD2}	—	25	ns	
\overline{WE} delay time	t_{WCD}	—	25	ns	
\overline{CAS} pulse width 1	t_{CAS1}	$1.5 t_{cyc} - 20$	—	ns	
\overline{CAS} pulse width 2	t_{CAS2}	$1.0 t_{cyc} - 20$	—	ns	
\overline{CAS} pulse width 3	t_{CAS3}	$1.0 t_{cyc} - 20$	—	ns	
\overline{RAS} access time	t_{RAC}	—	$2.5 t_{cyc} - 40$	ns	
Address access time	t_{AA}	—	$2.0 t_{cyc} - 50$	ns	
\overline{CAS} access time	t_{CAC}	—	$1.5 t_{cyc} - 50$	ns	
\overline{WE} setup time	t_{WCS}	$0.5 t_{cyc} - 20$	—	ns	
\overline{WE} hold time	t_{WCH}	$0.5 t_{cyc} - 15$	—	ns	
Write data setup time	t_{WDS}	$0.5 t_{cyc} - 20$	—	ns	
\overline{WE} write data hold time	t_{WDH}	$0.5 t_{cyc} - 15$	—	ns	
\overline{CAS} setup time 1	t_{CSR1}	$0.5 t_{cyc} - 20$	—	ns	
\overline{CAS} setup time 2	t_{CSR2}	$0.5 t_{cyc} - 15$	—	ns	
\overline{CAS} hold time	t_{CHR}	$0.5 t_{cyc} - 15$	—	ns	
\overline{RAS} pulse width	t_{RAS}	$1.5 t_{cyc} - 15$	—	ns	

Note: In order to secure the address hold time relative to the rise of the \overline{RD} strobe, address update mode 2 should be used. For details see section 6.3.5, Address Output Method.

Table 21.7 Timing of On-Chip Supporting ModulesCondition: $T_a = -20^{\circ}\text{C}$ to $+75^{\circ}\text{C}$ Condition A: $V_{CC} = 5.0\text{ V} \pm 10\%$, $AV_{CC} = 5.0\text{ V} \pm 10\%$, $V_{REF} = 4.5$ to AV_{CC} , $V_{SS} = AV_{SS} = 0\text{ V}$, $f_{max} = 20\text{ MHz}$ Condition B: $V_{CC} = 5.0\text{ V} \pm 10\%$, $AV_{CC} = 5.0\text{ V} \pm 10\%$, $V_{REF} = 4.5$ to AV_{CC} , $V_{SS} = AV_{SS} = 0\text{ V}$, $f_{max} = 25\text{ MHz}$

Module	Item	Symbol	Condition		Unit	Test Conditions	
			Min	Max			
Ports and TPC	Output data delay time	t_{PWD}	—	50	ns	Figure 21.21	
	Input data setup time	t_{PRS}	50	—	ns		
	Input data hold time	t_{PRH}	50	—	ns		
16-bit timer	Timer output delay time	t_{TOCD}	—	50	ns	Figure 21.22	
	Timer input setup time	t_{TICS}	50	—	ns		
	Timer clock input setup time	t_{TCKS}	50	—	ns		Figure 21.23
Timer clock pulse width	Single edge	t_{TCKWH}	1.5	—	t_{cyc}		
	Both edges	t_{TCKWL}	2.5	—	t_{cyc}		
8-bit timer	Timer output delay time	t_{TOCD}	—	50	ns	Figure 21.22	
	Timer input setup time	t_{TICS}	50	—	ns		
	Timer clock input setup time	t_{TCKS}	50	—	ns	Figure 21.23	
	Timer clock pulse width	Single edge	t_{TCKWH}	1.5	—		t_{cyc}
		Both edges	t_{TCKWL}	2.5	—		t_{cyc}

Module	Item	Symbol	Condition		Unit	Test Conditions		
			Min	Max				
SCI	Input clock cycle	Asynchronous	$t_{S_{cyc}}$	4	—	t_{cyc}	Figure 21.24	
		Synchronous		6	—	t_{cyc}		
	Input clock rise time		t_{SCKr}	—	1.5	t_{cyc}		
	Input clock fall time		t_{SCKf}	—	1.5	t_{cyc}		
	Input clock pulse width		t_{SCKW}	0.4	0.6	$t_{S_{cyc}}$		
	Transmit data delay time		t_{TXD}	—	100	ns		Figure 21.25
	Receive data setup time (synchronous)		t_{RXS}	100	—	ns		
	Receive data hold time (synchronous)	Clock input	t_{RXH}	100	—	ns		
Clock output			0	—	ns			
DMAC	\overline{TEND} delay time 1		t_{TED1}	—	50	ns	Figure 21.25, figure 21.26	
	\overline{TEND} delay time 2		t_{TED2}	—	50	ns		
	\overline{DREQ} setup time		t_{DRQS}	25	—	ns	Figure 21.27	
	\overline{DREQ} hold time		t_{DRQH}	10	—	ns		

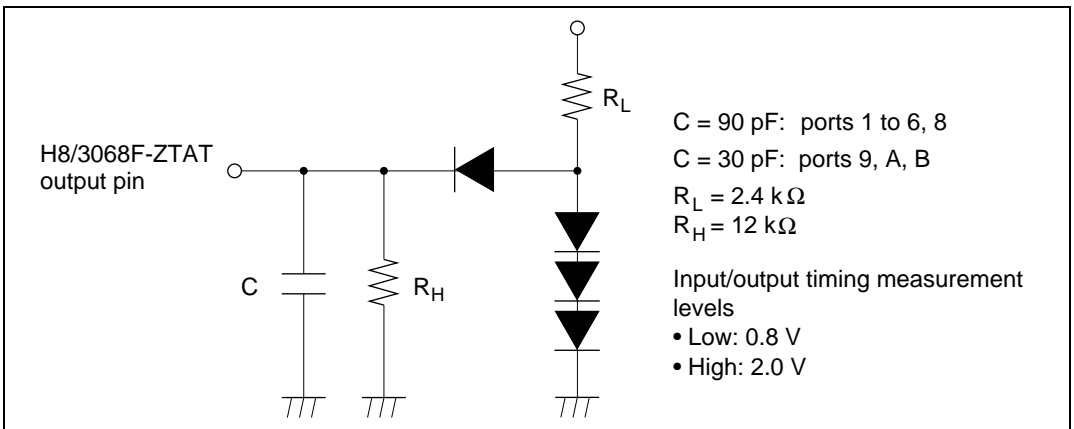

Figure 21.3 Output Load Circuit

21.1.4 A/D Conversion Characteristics

Table 21.8 lists the A/D conversion characteristics.

Table 21.8 A/D Conversion Characteristics

Condition: $T_a = -20^{\circ}\text{C}$ to $+75^{\circ}\text{C}$

Condition A: $V_{CC} = 5.0\text{ V} \pm 10\%$, $AV_{CC} = 5.0\text{ V} \pm 10\%$, $V_{REF} = 4.5$ to AV_{CC} , $V_{SS} = AV_{SS} = 0\text{ V}$, $f_{max} = 20\text{ MHz}$

Condition B: $V_{CC} = 5.0\text{ V} \pm 10\%$, $AV_{CC} = 5.0\text{ V} \pm 10\%$, $V_{REF} = 4.5$ to AV_{CC} , $V_{SS} = AV_{SS} = 0\text{ V}$, $f_{max} = 25\text{ MHz}$

Item		Condition			Unit	
		A and B				
		Min	Typ	Max		
Conversion time: 134 states	Resolution	10	10	10	bits	
	Conversion time (single mode)	—	—	134	t_{cyc}	
	Analog input capacitance	—	—	20	pF	
	Permissible signal- source impedance	$\phi \leq 13\text{ MHz}$	—	—	10	$k\Omega$
		$\phi > 13\text{ MHz}$	—	—	5	$k\Omega$
		$4.0\text{ V} \leq AV_{CC} \leq 5.5\text{ V}$	—	—	—	$k\Omega$
		$3.0\text{ V} \leq AV_{CC} < 4.0\text{ V}$	—	—	—	$k\Omega$
	Nonlinearity error	—	—	± 3.5	LSB	
	Offset error	—	—	± 3.5	LSB	
	Full-scale error	—	—	± 3.5	LSB	
Quantization error	—	—	± 0.5	LSB		
Absolute accuracy	—	—	± 4.0	LSB		

Item		Condition			Unit	
		A and B				
		Min	Typ	Max		
Conversion time: 70 states	Resolution	10	10	10	bits	
	Conversion time (single mode)	—	—	70	t _{cyc}	
	Analog input capacitance	—	—	20	pF	
	Permissible signal- source impedance	$\phi \leq 13$ MHz	—	—	5	k Ω
		$\phi > 13$ MHz	—	—	3	k Ω
		$4.0\text{ V} \leq AV_{CC} \leq 5.5\text{ V}$	—	—	—	k Ω
		$3.0\text{ V} \leq AV_{CC} < 4.0\text{ V}$	—	—	—	k Ω
	Nonlinearity error	—	—	± 7.5	LSB	
	Offset error	—	—	± 7.5	LSB	
	Full-scale error	—	—	± 7.5	LSB	
	Quantization error	—	—	± 0.5	LSB	
Absolute accuracy	—	—	± 8.0	LSB		

21.1.5 D/A Conversion Characteristics

Table 21.9 lists the D/A conversion characteristics.

Table 21.9 D/A Conversion Characteristics

Condition: $T_a = -20^{\circ}\text{C}$ to $+75^{\circ}\text{C}$

Condition A: $V_{CC} = 5.0\text{ V} \pm 10\%$, $AV_{CC} = 5.0\text{ V} \pm 10\%$, $V_{REF} = 4.5$ to AV_{CC} , $V_{SS} = AV_{SS} = 0\text{ V}$,
 $f_{max} = 20\text{ MHz}$

Condition B: $V_{CC} = 5.0\text{ V} \pm 10\%$, $AV_{CC} = 5.0\text{ V} \pm 10\%$, $V_{REF} = 4.5$ to AV_{CC} , $V_{SS} = AV_{SS} = 0\text{ V}$,
 $f_{max} = 25\text{ MHz}$

Item	Condition			Unit	Test Conditions
	Min	Typ	Max		
Resolution	8	8	8	bits	
Conversion time (centering time)	—	—	10	μs	20 pF capacitive load
Absolute accuracy	—	± 1.5	± 2.0	LSB	2 M Ω resistive load
	—	—	± 1.5	LSB	4 M Ω resistive load

21.1.6 Flash Memory Characteristics

Table 21.10 shows the flash memory characteristics.

Table 21.10 Flash Memory Characteristics

Conditions: $V_{CC} = 4.5$ to 5.5 V, $AV_{CC} = 4.5$ to 5.5 V, $V_{SS} = AV_{SS} = 0$ V,
 $T_a = 0^{\circ}\text{C}$ to $+75^{\circ}\text{C}$ (operating temperature range for programming/erasing)

Item	Symbol	Min	Typ	Max	Unit	Notes	
Programming time* ¹ * ² * ⁴	t_P	—	10	200	ms/ 128 bytes		
Erase time* ¹ * ³ * ⁵	t_E	—	100	1200	ms/block		
Reprogramming count	N_{WEC}	100* ⁶	10,000* ⁷	—	Times		
Data retention period	t_{DRP}	10* ⁸	—	—	Years		
Programming	Wait time after SWE bit setting* ¹	t_{SSWE}	1	1	—	μs	
	Wait time after PSU bit setting* ¹	t_{SPSU}	50	50	—	μs	
	Wait time after P bit setting* ¹ * ⁴	t_{SP30}	28	30	32	μs	Programming time wait
		t_{SP200}	198	200	202	μs	Programming time wait
		t_{SP10}	8	10	12	μs	Additional-programming time wait
	Wait time after P bit clear* ¹	t_{CP}	5	5	—	μs	
	Wait time after PSU bit clear* ¹	t_{CPSU}	5	5	—	μs	
	Wait time after PV bit setting* ¹	t_{SPV}	4	4	—	μs	
	Wait time after H'FF dummy write* ¹	t_{SPVR}	2	2	—	μs	
	Wait time after PV bit clear* ¹	t_{CPV}	2	2	—	μs	
	Wait time after SWE bit clear* ¹	t_{CSWE}	100	100	—	μs	
	Maximum programming count* ¹ * ⁴	N	—	—	1000	Times	
	Erase	Wait time after SWE bit setting* ¹	t_{SSWE}	1	1	—	μs
Wait time after ESU bit setting* ¹		t_{SESU}	100	100	—	μs	
Wait time after E bit setting* ¹ * ⁵		t_{SE}	10	10	100	ms	Erase time wait
Wait time after E bit clear* ¹		t_{CE}	10	10	—	μs	
Wait time after ESU bit clear* ¹		t_{CESU}	10	10	—	μs	

Item		Symbol	Min	Typ	Max	Unit	Notes
Erase	Wait time after EV bit setting* ¹	t_{sev}	20	20	—	μs	
	Wait time after H'FF dummy write* ¹	t_{sevr}	2	2	—	μs	
	Wait time after EV bit clear* ¹	t_{cev}	4	4	—	μs	
	Wait time after SWE bit clear* ¹	t_{cswe}	100	100	—	μs	
	Maximum erase count* ¹ * ⁴	N	12	—	120	Times	

- Notes: 1. Make each time setting in accordance with the program/program-verify flowchart or erase/erase-verify flowchart.
2. Programming time per 128 bytes (Shows the total period for which the P-bit in the flash memory control register (FLMCR1) is set. It does not include the programming verification time.)
3. Block erase time (Shows the total period for which the E-bit in FLMCR1 is set. It does not include the erase verification time.)
4. To specify the maximum programming time ($t_p(\text{max})$) in the 128-byte programming flowchart, set the maximum value (1000) for the maximum programming count (N). The wait time after P bit setting should be changed as follows according to the value of the programming counter (n).

Programming counter (n) = 1 to 6:	$t_{sp30} = 30 \mu\text{s}$
Programming counter (n) = 7 to 1000:	$t_{sp200} = 200 \mu\text{s}$
Programming counter (n) [in additional programming] = 1 to 6:	$t_{sp10} = 10 \mu\text{s}$

5. For the maximum erase time ($t_E(\text{max})$), the following relationship applies between the wait time after E bit setting (t_{se}) and the maximum erase count (N):

$$t_E(\text{max}) = \text{Wait time after E bit setting } (t_{se}) \times \text{maximum erase count } (N)$$

To set the maximum erase time, the values of t_{se} and N should be set so as to satisfy the above formula.

Examples: When $t_{se} = 100$ [ms], N = 12 times

When $t_{se} = 10$ [ms], N = 120 times

6. Minimum number of times at which all characteristics are guaranteed after reprogramming. (Reprogramming count from 1 to minimum value is guaranteed.)
7. Reference characteristics at 25°C. (This is an indication that reprogramming operations can normally be performed up to this figure.)
8. Data retention characteristics when reprogramming is performed correctly within the specification values, including the minimum data retention period.

21.2 Operational Timing

This section shows timing diagrams.

21.2.1 Clock Timing

Clock timing is shown as follows:

- Oscillator settling timing

Figure 21.4 shows the oscillator settling timing.

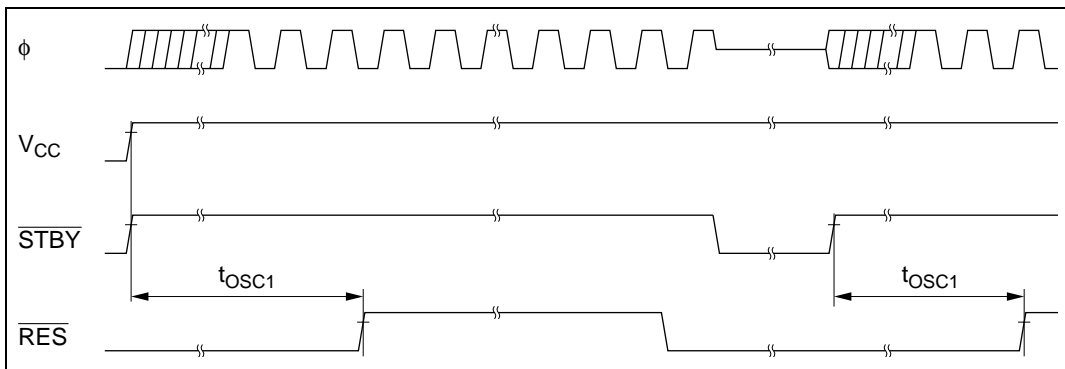

Figure 21.4 Oscillator Settling Timing

21.2.2 Control Signal Timing

Control signal timing is shown as follows:

- Reset input timing
Figure 21.5 shows the reset input timing.
- Reset output timing*
Figure 21.6 shows the reset output timing.
- Interrupt input timing
Figure 21.7 shows the interrupt input timing for NMI and \overline{IRQ}_5 to \overline{IRQ}_0 .

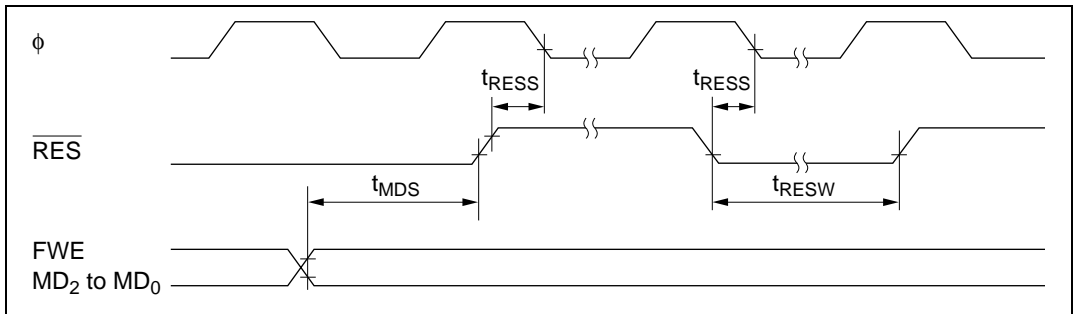

Figure 21.5 Reset Input Timing

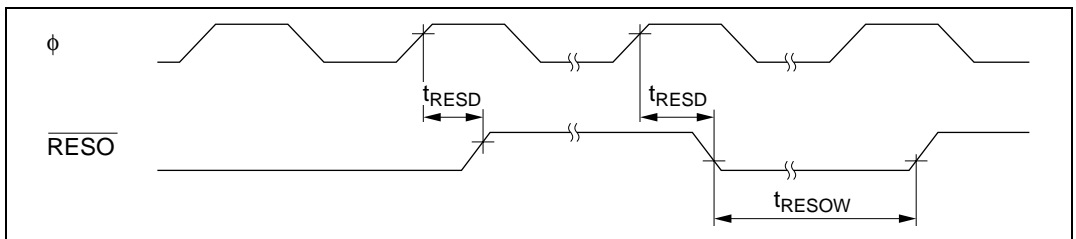

Figure 21.6 Reset Output Timing*

Note: * This function is used only in mask ROM models, and is not provided in flash memory models.

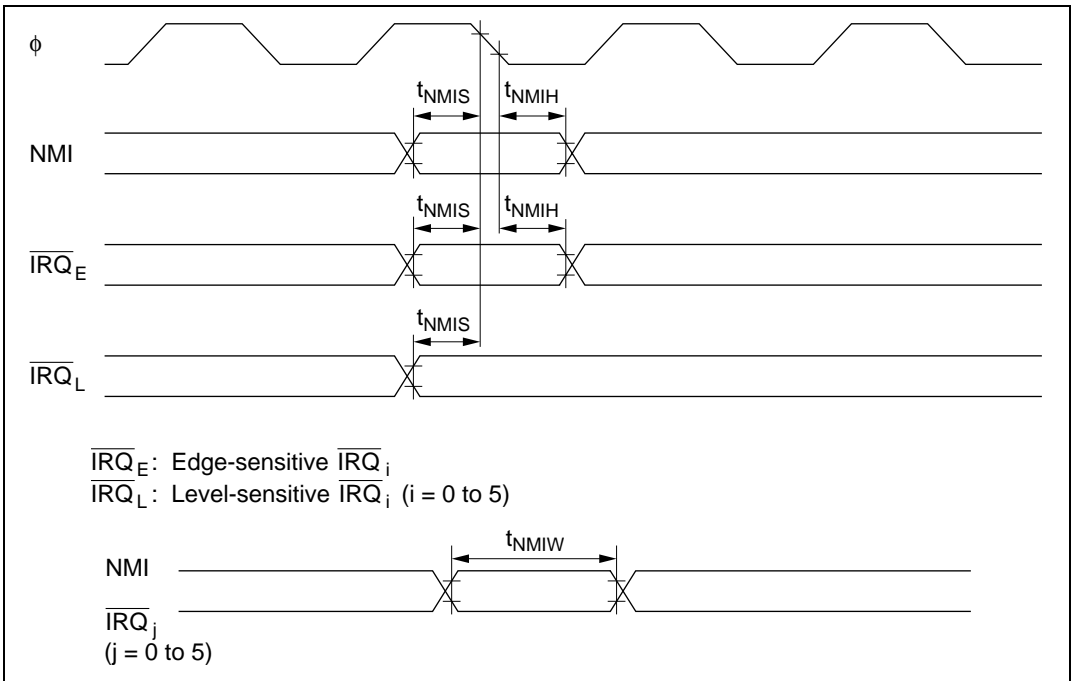

Figure 21.7 Interrupt Input Timing

21.2.3 Bus Timing

Bus timing is shown as follows:

- Basic bus cycle: two-state access
Figure 21.8 shows the timing of the external two-state access cycle.
- Basic bus cycle: three-state access
Figure 21.9 shows the timing of the external three-state access cycle.
- Basic bus cycle: three-state access with one wait state
Figure 21.10 shows the timing of the external three-state access cycle with one wait state inserted.
- Bus-release mode timing
Figure 21.11 shows the bus-release mode timing.

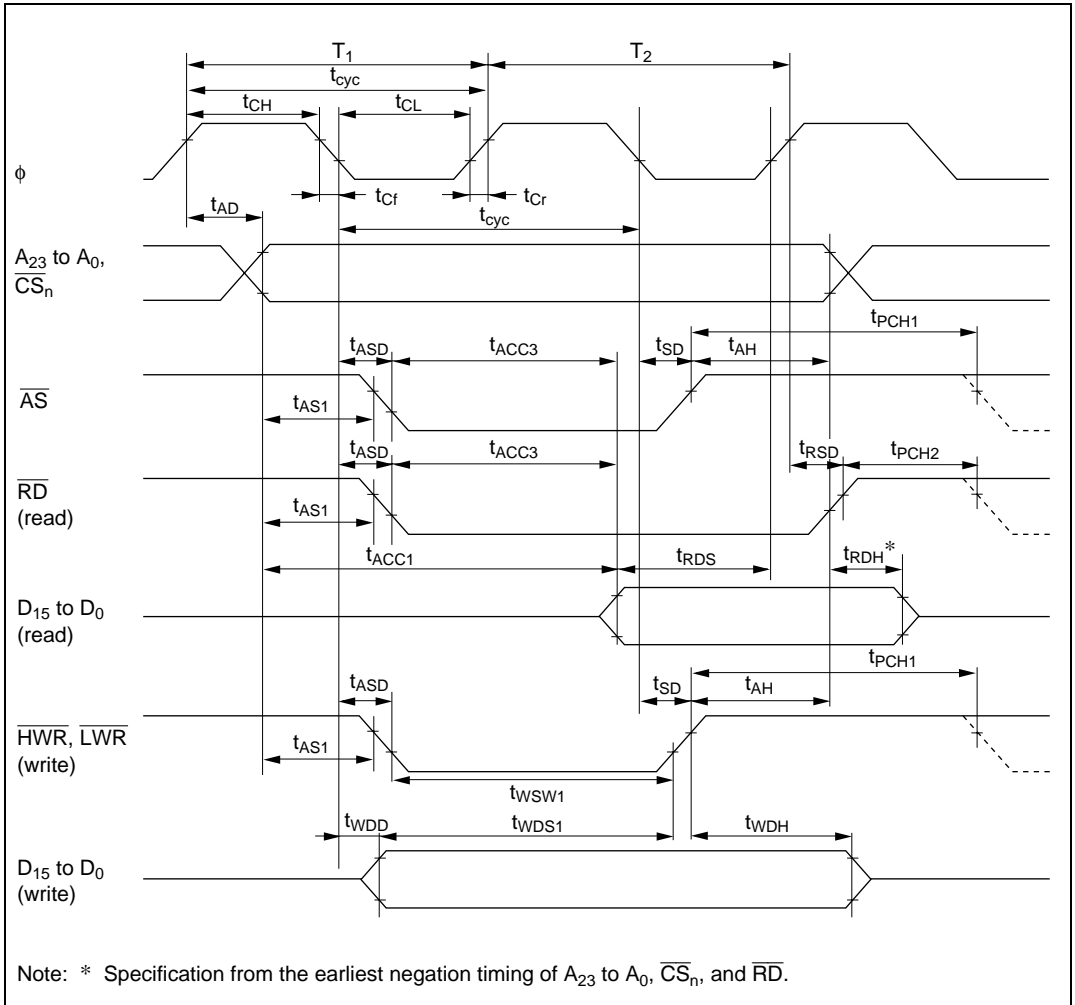

Figure 21.8 Basic Bus Cycle: Two-State Access

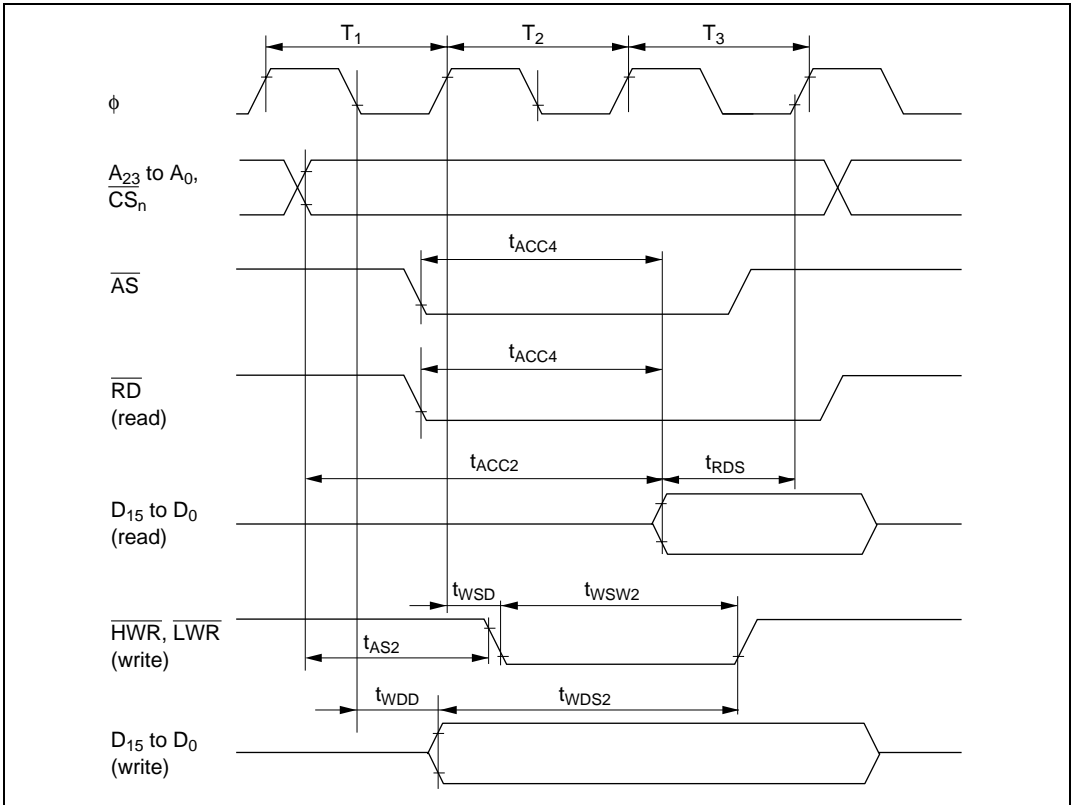

Figure 21.9 Basic Bus Cycle: Three-State Access

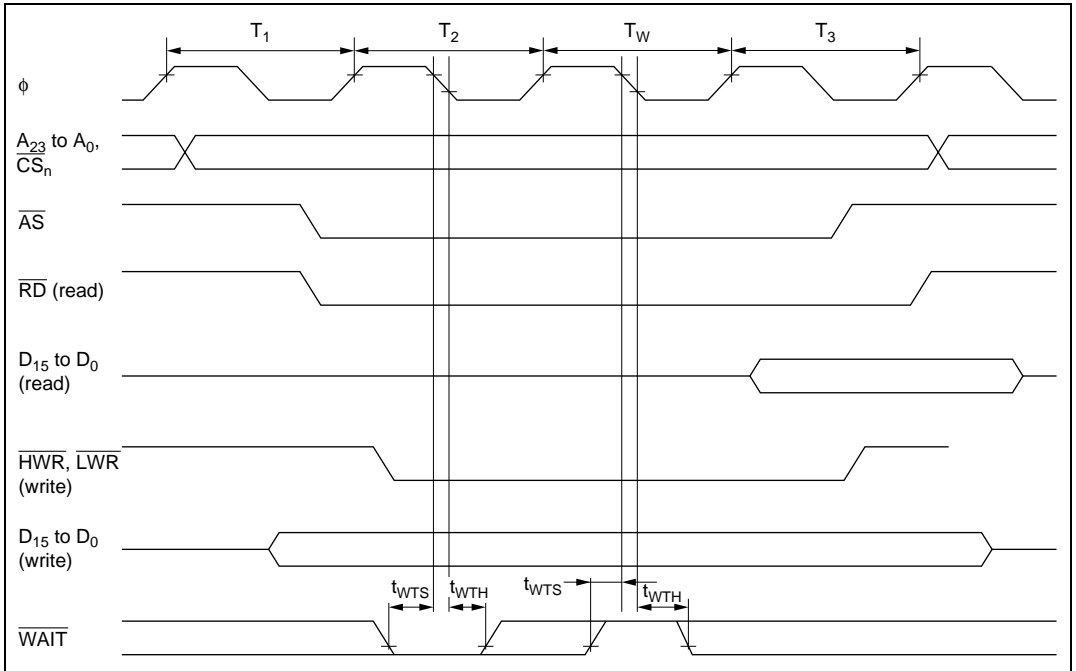

Figure 21.10 Basic Bus Cycle: Three-State Access with One Wait State

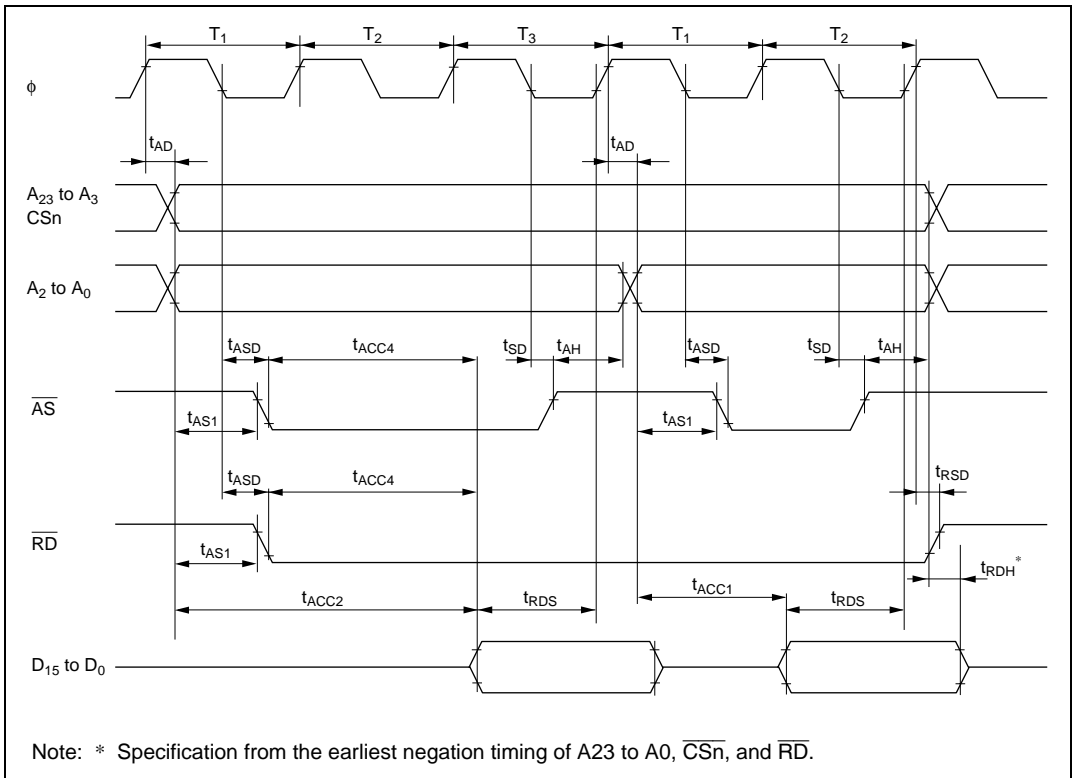

Figure 21.11 Burst ROM Access Timing: Two-State Access

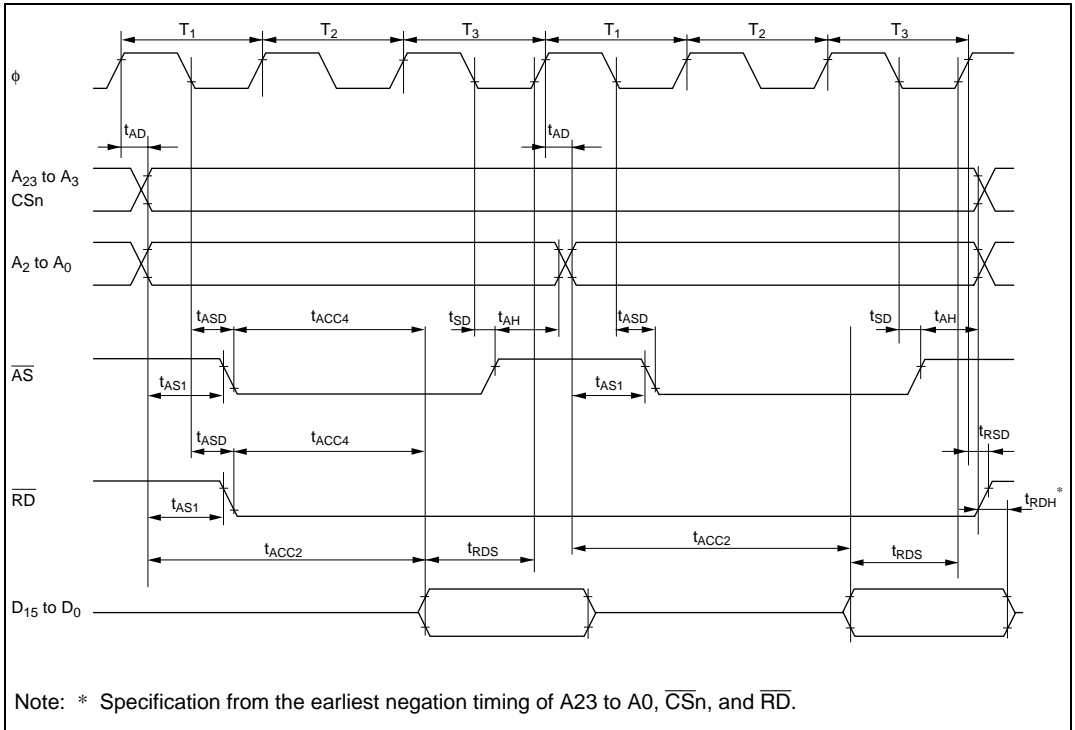

Figure 21.12 Burst ROM Access Timing: Three-State Access

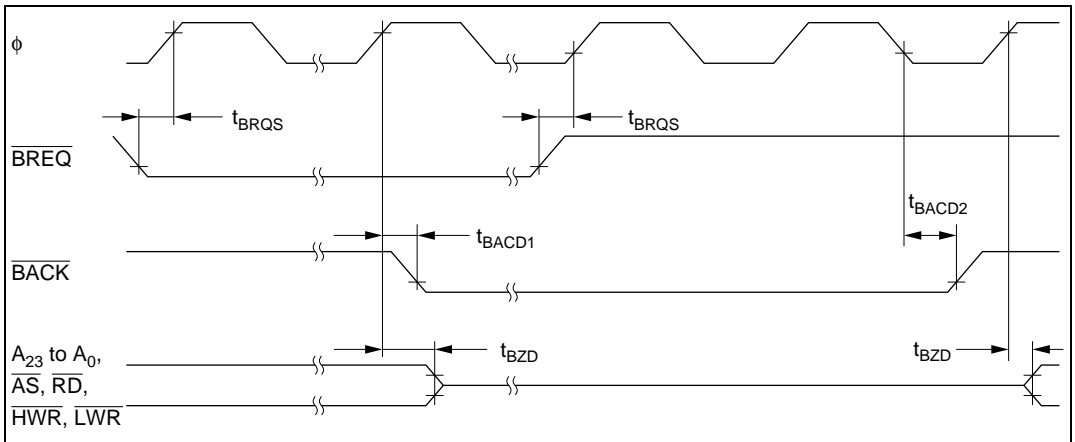

Figure 21.13 Bus-Release Mode Timing

21.2.4 DRAM Interface Bus Timing

DRAM interface bus timing is shown as follows:

- DRAM bus timing: read and write access
Figure 21.14 shows the timing of the read and write access.
- DRAM bus timing: CAS before RAS refresh
Figure 21.15 shows the timing of the CAS before RAS refresh.
- DRAM bus timing: self-refresh
Figure 21.16 shows the timing of the self-refresh.

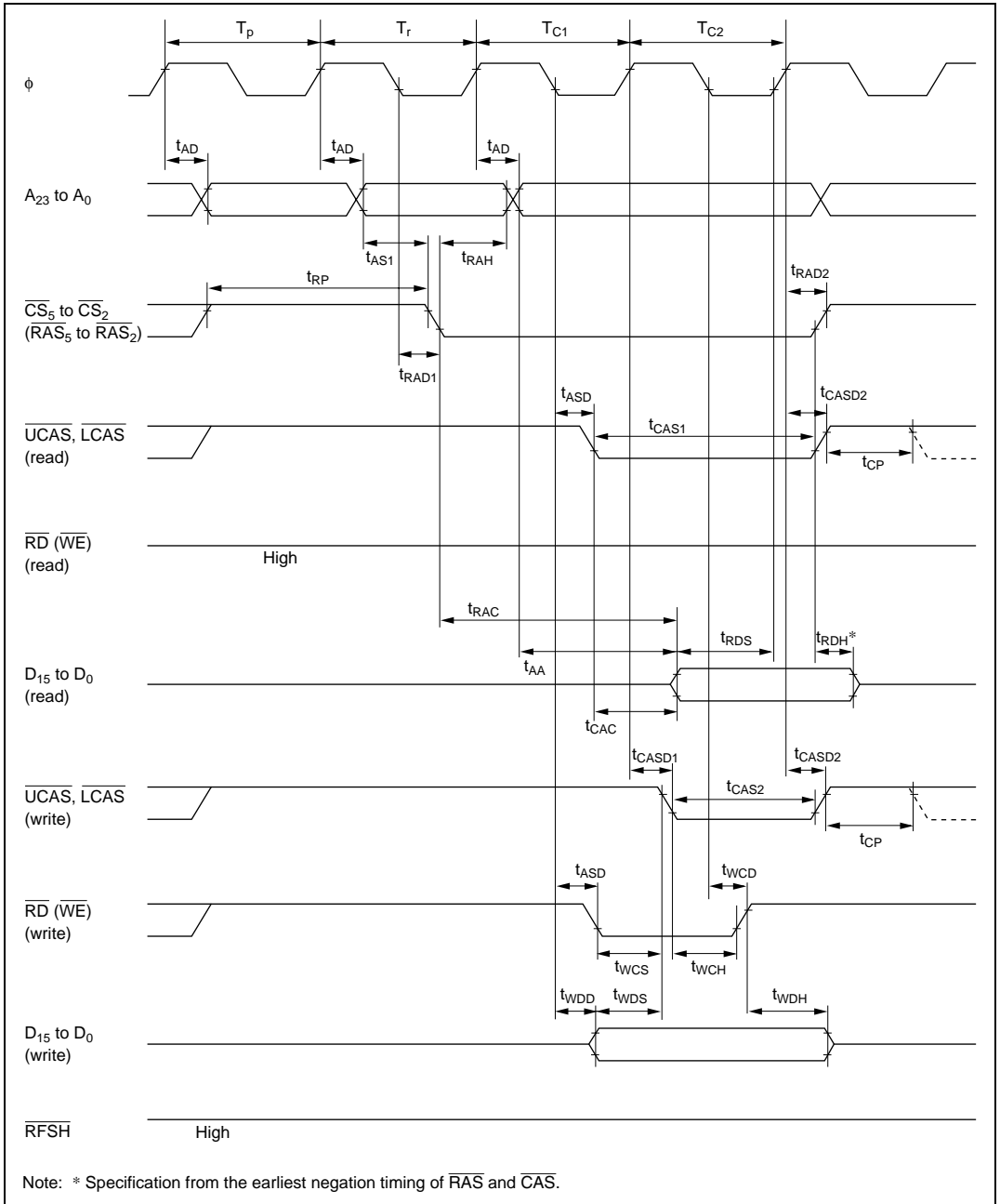

Figure 21.14 DRAM Bus Timing (Read/Write)

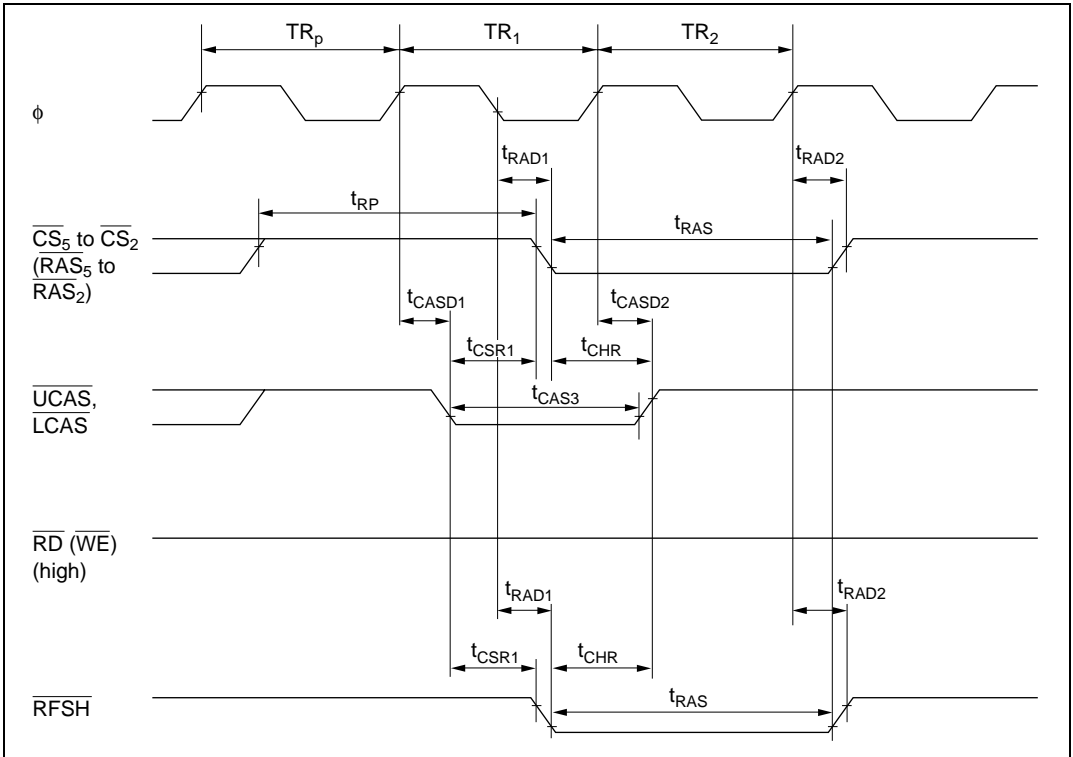

Figure 21.15 DRAM Bus Timing (CAS Before RAS Refresh)

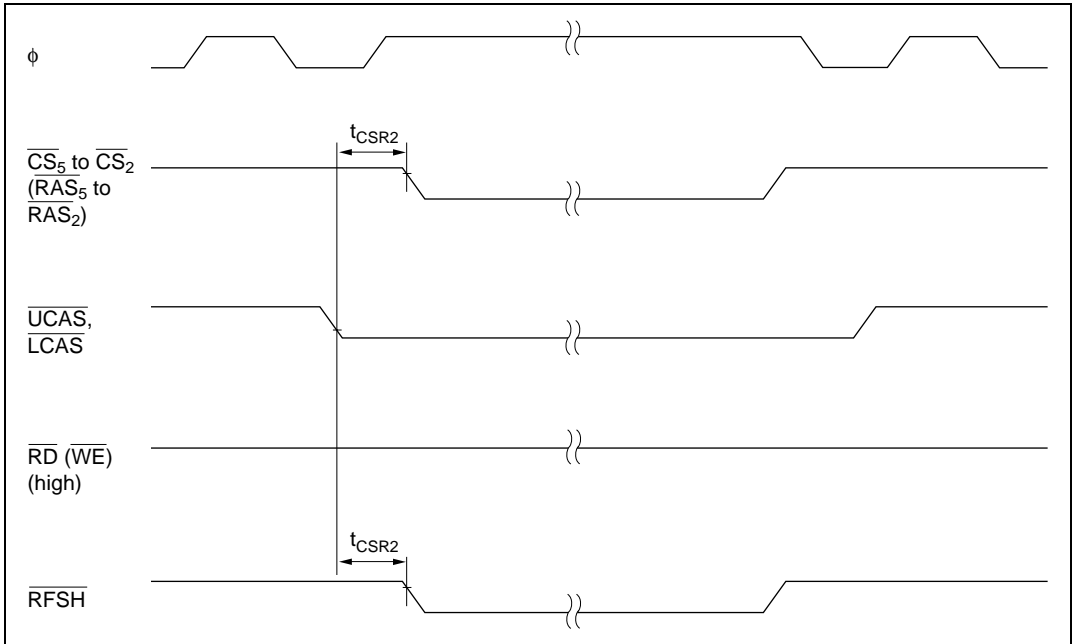

Figure 21.16 DRAM Bus Timing (Self-Refresh)

21.2.5 TPC and I/O Port Timing

Figure 21.17 shows the TPC and I/O port input/output timing.

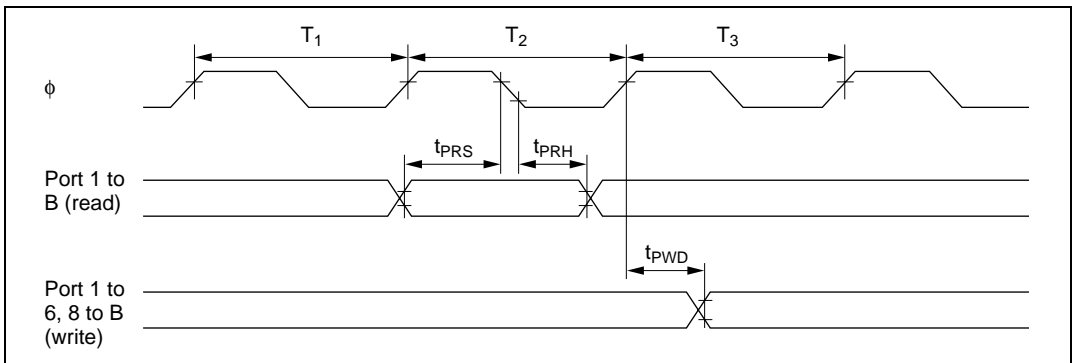

Figure 21.17 TPC and I/O Port Input/Output Timing

21.2.6 Timer Input/Output Timing

16-bit timer and 8-bit timer timing is shown below.

- Timer input/output timing
Figure 21.18 shows the timer input/output timing.
- Timer external clock input timing
Figure 21.19 shows the timer external clock input timing.

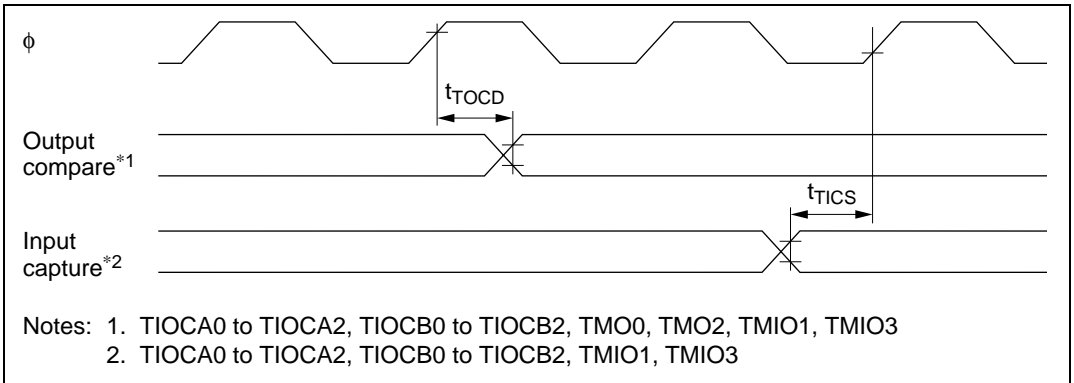

Figure 21.18 Timer Input/Output Timing

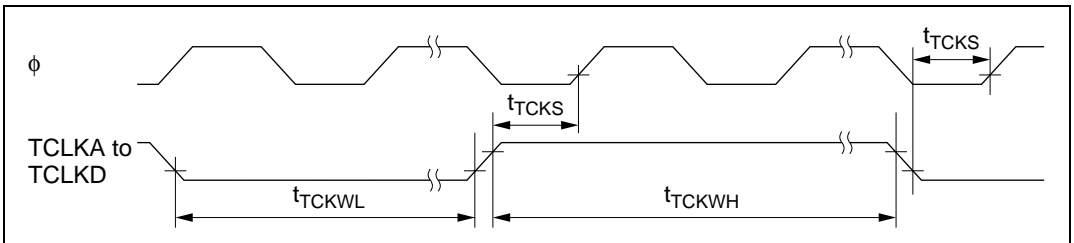

Figure 21.19 Timer External Clock Input Timing

21.2.7 SCI Input/Output Timing

SCI timing is shown as follows:

- SCI input clock timing
Figure 21.20 shows the SCI input clock timing.
- SCI input/output timing (synchronous mode)
Figure 21.21 shows the SCI input/output timing in synchronous mode.

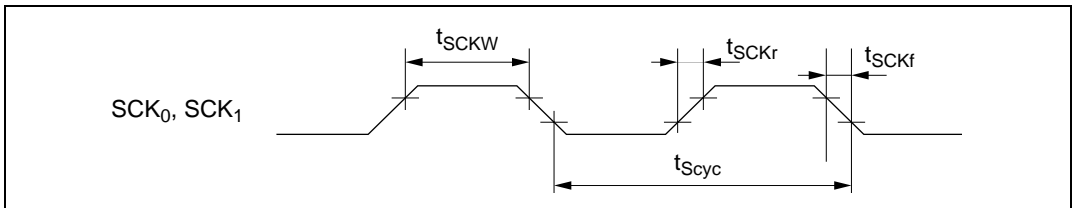

Figure 21.20 SCI Input Clock Timing

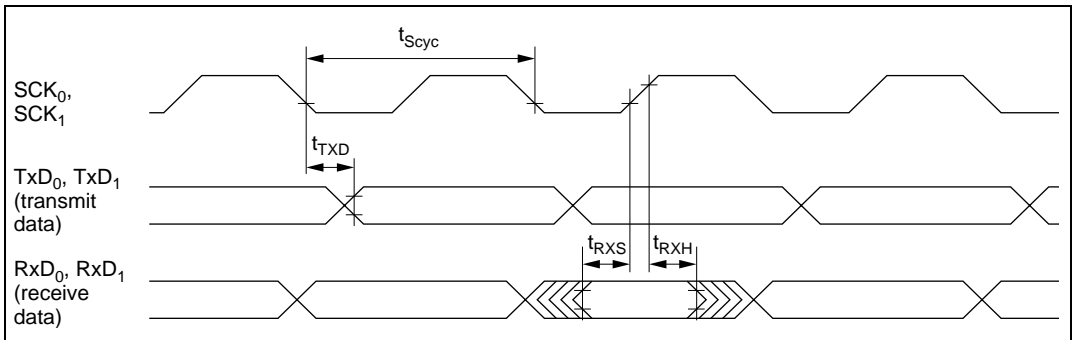

Figure 21.21 SCI Input/Output Timing in Synchronous Mode

21.2.8 DMAC Timing

DMAC timing is shown as follows.

- DMAC $\overline{\text{TEND}}$ output timing for 2 state access

Figure 21.22 shows the DMAC $\overline{\text{TEND}}$ output timing for 2 state access.

- DMAC $\overline{\text{TEND}}$ output timing for 3 state access

Figure 21.23 shows the DMAC $\overline{\text{TEND}}$ output timing for 3 state access.

- DMAC $\overline{\text{DREQ}}$ input timing

Figure 21.24 shows DMAC $\overline{\text{DREQ}}$ input timing.

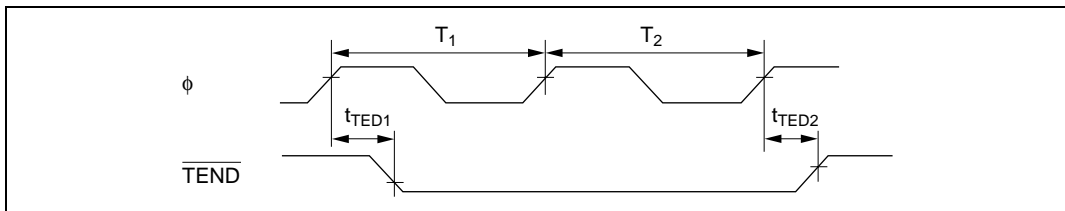

Figure 21.22 DMAC $\overline{\text{TEND}}$ Output Timing for 2 State Access

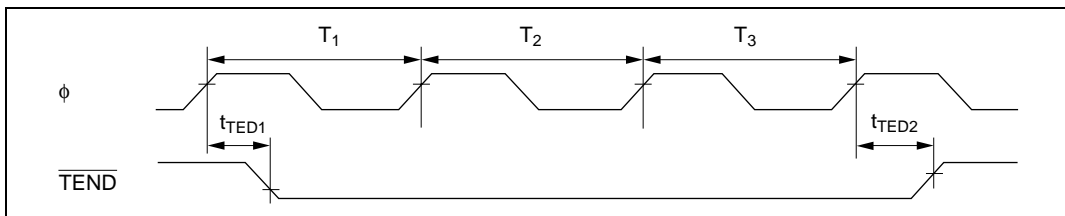

Figure 21.23 DMAC $\overline{\text{TEND}}$ Output Timing for 3 State Access

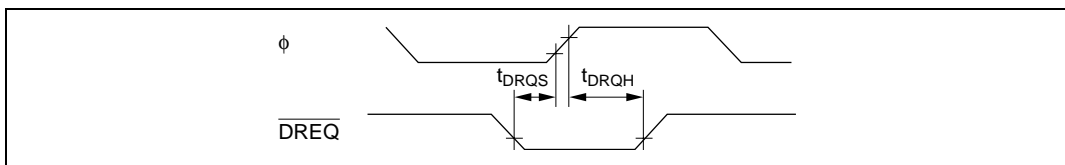

Figure 21.24 DMAC $\overline{\text{DREQ}}$ Input Timing

Appendix A Instruction Set

A.1 Instruction List

Operand Notation

Symbol	Description
Rd	General destination register
Rs	General source register
Rn	General register
ERd	General destination register (address register or 32-bit register)
ERs	General source register (address register or 32-bit register)
ERn	General register (32-bit register)
(EAd)	Destination operand
(EAs)	Source operand
PC	Program counter
SP	Stack pointer
CCR	Condition code register
N	N (negative) flag in CCR
Z	Z (zero) flag in CCR
V	V (overflow) flag in CCR
C	C (carry) flag in CCR
disp	Displacement
→	Transfer from the operand on the left to the operand on the right, or transition from the state on the left to the state on the right
+	Addition of the operands on both sides
–	Subtraction of the operand on the right from the operand on the left
×	Multiplication of the operands on both sides
÷	Division of the operand on the left by the operand on the right
^	Logical AND of the operands on both sides
∨	Logical OR of the operands on both sides
⊕	Exclusive logical OR of the operands on both sides
¬	NOT (logical complement)
(), < >	Contents of operand

Note: General registers include 8-bit registers (R0H to R7H and R0L to R7L) and 16-bit registers (R0 to R7 and E0 to E7).

Condition Code Notation

Symbol	Description
◇	Changed according to execution result
*	Undetermined (no guaranteed value)
0	Cleared to 0
1	Set to 1
—	Not affected by execution of the instruction
△	Varies depending on conditions, described in notes

Table A.1 Instruction Set

1. Data transfer instructions

Mnemonic	Operand Size	Addressing Mode and Instruction Length (bytes)							Operation	Condition Code						No. of States ^{*1}		
		#xx	Rn	@ERn	@(d, ERn)	@-ERn/@ERn+	@aa	@(d, PC)		@@aa	I	H	N	Z	V	C	Normal	Advanced
MOV.B #xx:8, Rd	B	2							#xx:8 → Rd8	—	—	↕	↕	0	—	2		
MOV.B Rs, Rd	B		2						Rs8 → Rd8	—	—	↕	↕	0	—	2		
MOV.B @ERs, Rd	B			2					@ERs → Rd8	—	—	↕	↕	0	—	4		
MOV.B @(d:16, ERs), Rd	B				4				@(d:16, ERs) → Rd8	—	—	↕	↕	0	—	6		
MOV.B @(d:24, ERs), Rd	B					8			@(d:24, ERs) → Rd8	—	—	↕	↕	0	—	10		
MOV.B @ERs+, Rd	B						2		@ERs → Rd8 ERs32+1 → ERs32	—	—	↕	↕	0	—	6		
MOV.B @aa:8, Rd	B							2	@aa:8 → Rd8	—	—	↕	↕	0	—	4		
MOV.B @aa:16, Rd	B							4	@aa:16 → Rd8	—	—	↕	↕	0	—	6		
MOV.B @aa:24, Rd	B							6	@aa:24 → Rd8	—	—	↕	↕	0	—	8		
MOV.B Rs, @ERd	B			2					Rs8 → @ERd	—	—	↕	↕	0	—	4		
MOV.B Rs, @(d:16, ERd)	B				4				Rs8 → @(d:16, ERd)	—	—	↕	↕	0	—	6		
MOV.B Rs, @(d:24, ERd)	B					8			Rs8 → @(d:24, ERd)	—	—	↕	↕	0	—	10		
MOV.B Rs, @-ERd	B						2		ERd32-1 → ERd32 Rs8 → @ERd	—	—	↕	↕	0	—	6		
MOV.B Rs, @aa:8	B							2	Rs8 → @aa:8	—	—	↕	↕	0	—	4		
MOV.B Rs, @aa:16	B							4	Rs8 → @aa:16	—	—	↕	↕	0	—	6		
MOV.B Rs, @aa:24	B							6	Rs8 → @aa:24	—	—	↕	↕	0	—	8		
MOV.W #xx:16, Rd	W	4							#xx:16 → Rd16	—	—	↕	↕	0	—	4		
MOV.W Rs, Rd	W		2						Rs16 → Rd16	—	—	↕	↕	0	—	2		
MOV.W @ERs, Rd	W			2					@ERs → Rd16	—	—	↕	↕	0	—	4		
MOV.W @(d:16, ERs), Rd	W				4				@(d:16, ERs) → Rd16	—	—	↕	↕	0	—	6		
MOV.W @(d:24, ERs), Rd	W					8			@(d:24, ERs) → Rd16	—	—	↕	↕	0	—	10		
MOV.W @ERs+, Rd	W						2		@ERs → Rd16 ERs32+2 → @ERd32	—	—	↕	↕	0	—	6		
MOV.W @aa:16, Rd	W							4	@aa:16 → Rd16	—	—	↕	↕	0	—	6		

Mnemonic	Operand Size	Addressing Mode and Instruction Length (bytes)								Operation	Condition Code						No. of States*1	
		#xx	Rn	@ERn	@(d, ERn)	@-ERn/@ERn+	@aa	@(d, PC)	@@aa		I	H	N	Z	V	C	Normal	Advanced
MOV.W @aa:24, Rd	W							6		@aa:24 → Rd16	—	—	↕	↕	0	—	8	
MOV.W Rs, @ERd	W			2						Rs16 → @ERd	—	—	↕	↕	0	—	4	
MOV.W Rs, @(d:16, ERd)	W				4					Rs16 → @(d:16, ERd)	—	—	↕	↕	0	—	6	
MOV.W Rs, @(d:24, ERd)	W					8				Rs16 → @(d:24, ERd)	—	—	↕	↕	0	—	10	
MOV.W Rs, @-ERd	W						2			ERd32-2 → ERd32 Rs16 → @ERd	—	—	↕	↕	0	—	6	
MOV.W Rs, @aa:16	W							4		Rs16 → @aa:16	—	—	↕	↕	0	—	6	
MOV.W Rs, @aa:24	W							6		Rs16 → @aa:24	—	—	↕	↕	0	—	8	
MOV.L #xx:32, Rd	L	6								#xx:32 → Rd32	—	—	↕	↕	0	—	6	
MOV.L ERs, ERd	L		2							ERs32 → ERd32	—	—	↕	↕	0	—	2	
MOV.L @ERs, ERd	L			4						@ERs → ERd32	—	—	↕	↕	0	—	8	
MOV.L @(d:16, ERs), ERd	L				6					@(d:16, ERs) → ERd32	—	—	↕	↕	0	—	10	
MOV.L @(d:24, ERs), ERd	L					10				@(d:24, ERs) → ERd32	—	—	↕	↕	0	—	14	
MOV.L @ERs+, ERd	L						4			@ERs → ERd32 ERs32+4 → ERs32	—	—	↕	↕	0	—	10	
MOV.L @aa:16, ERd	L							6		@aa:16 → ERd32	—	—	↕	↕	0	—	10	
MOV.L @aa:24, ERd	L							8		@aa:24 → ERd32	—	—	↕	↕	0	—	12	
MOV.L ERs, @ERd	L			4						ERs32 → @ERd	—	—	↕	↕	0	—	8	
MOV.L ERs, @(d:16, ERd)	L				6					ERs32 → @(d:16, ERd)	—	—	↕	↕	0	—	10	
MOV.L ERs, @(d:24, ERd)	L					10				ERs32 → @(d:24, ERd)	—	—	↕	↕	0	—	14	
MOV.L ERs, @-ERd	L						4			ERd32-4 → ERd32 ERs32 → @ERd	—	—	↕	↕	0	—	10	
MOV.L ERs, @aa:16	L							6		ERs32 → @aa:16	—	—	↕	↕	0	—	10	
MOV.L ERs, @aa:24	L							8		ERs32 → @aa:24	—	—	↕	↕	0	—	12	
POP.W Rn	W								2	@SP → Rn16 SP+2 → SP	—	—	↕	↕	0	—	6	
POP.L ERn	L								4	@SP → ERn32 SP+4 → SP	—	—	↕	↕	0	—	10	

Mnemonic	Operand Size	Addressing Mode and Instruction Length (bytes)								Operation	Condition Code						No. of States*1		
		#xx	Rn	@ ERn	@ (d, ERn)	@-ERn/@ERn+	@ aa	@ (d, PC)	@ @aa			I	H	N	Z	V	C	Normal	Advanced
PUSH.W Rn	W									2	SP-2 → SP Rn16 → @SP	—	—	↕	↕	0	—	6	
PUSH.L ERn	L									4	SP-4 → SP ERn32 → @SP	—	—	↕	↕	0	—	10	
MOVPE @aa:16, Rd	B					4					Cannot be used in the H8/3068F	Cannot be used in the H8/3068F							
MOVPE Rs, @aa:16	B					4					Cannot be used in the H8/3068F	Cannot be used in the H8/3068F							











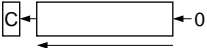
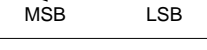
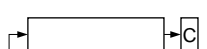

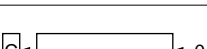
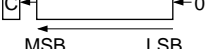
2. Arithmetic instructions

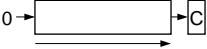
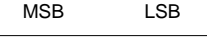
Mnemonic	Operand Size	Addressing Mode and Instruction Length (bytes)								Operation	Condition Code						No. of States ^{*1}	
		#xx	Rn	@ERn	@(d, ERn)	@-ERn/@ERn+	@aa	@(d, PC)	@@aa		I	H	N	Z	V	C	Normal	Advanced
ADD.B #xx:8, Rd	B	2								Rd8+#xx:8 → Rd8	—	↕	↕	↕	↕	↕	2	
ADD.B Rs, Rd	B	2								Rd8+Rs8 → Rd8	—	↕	↕	↕	↕	↕	2	
ADD.W #xx:16, Rd	W	4								Rd16+#xx:16 → Rd16	—	(1)	↕	↕	↕	↕	4	
ADD.W Rs, Rd	W	2								Rd16+Rs16 → Rd16	—	(1)	↕	↕	↕	↕	2	
ADD.L #xx:32, ERd	L	6								ERd32+#xx:32 → ERd32	—	(2)	↕	↕	↕	↕	6	
ADD.L ERs, ERd	L	2								ERd32+ERs32 → ERd32	—	(2)	↕	↕	↕	↕	2	
ADDX.B #xx:8, Rd	B	2								Rd8+#xx:8 +C → Rd8	—	↕	↕	(3)	↕	↕	2	
ADDX.B Rs, Rd	B	2								Rd8+Rs8 +C → Rd8	—	↕	↕	(3)	↕	↕	2	
ADDS.L #1, ERd	L	2								ERd32+1 → ERd32	—	—	—	—	—	—	2	
ADDS.L #2, ERd	L	2								ERd32+2 → ERd32	—	—	—	—	—	—	2	
ADDS.L #4, ERd	L	2								ERd32+4 → ERd32	—	—	—	—	—	—	2	
INC.B Rd	B	2								Rd8+1 → Rd8	—	—	↕	↕	—	↕	2	
INC.W #1, Rd	W	2								Rd16+1 → Rd16	—	—	↕	↕	—	↕	2	
INC.W #2, Rd	W	2								Rd16+2 → Rd16	—	—	↕	↕	↕	—	2	

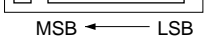
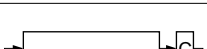
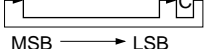
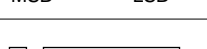
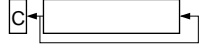
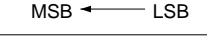
Mnemonic	Operand Size	Addressing Mode and Instruction Length (bytes)								Operation	Condition Code						No. of States ^{*1}	
		#xx	Rn	@ ERn	@ (d, ERn)	@ -ERn/@ ERn+	@ aa	@ (d, PC)	@ @aa		I	H	N	Z	V	C	Normal	Advanced
INC.L #1, ERd	L	2								ERd32+1 → ERd32	—	—	↓	↓	↓	—	2	
INC.L #2, ERd	L	2								ERd32+2 → ERd32	—	—	↓	↓	↓	—	2	
DAA Rd	B	2								Rd8 decimal adjust → Rd8	—	*	↓	↓	*	—	2	
SUB.B Rs, Rd	B	2								Rd8-Rs8 → Rd8	—		↓	↓	↓	↓	2	
SUB.W #xx:16, Rd	W	4								Rd16-#xx:16 → Rd16	—	(1)	↓	↓	↓	↓	4	
SUB.W Rs, Rd	W	2								Rd16-Rs16 → Rd16	—	(1)	↓	↓	↓	↓	2	
SUB.L #xx:32, ERd	L	6								ERd32-#xx:32 → ERd32	—	(2)	↓	↓	↓	↓	6	
SUB.L ERs, ERd	L	2								ERd32-ERs32 → ERd32	—	(2)	↓	↓	↓	↓	2	
SUBX.B #xx:8, Rd	B	2								Rd8-#xx:8-C → Rd8	—	↓	↓	(3)	↓	↓	2	
SUBX.B Rs, Rd	B	2								Rd8-Rs8-C → Rd8	—	↓	↓	(3)	↓	↓	2	
SUBS.L #1, ERd	L	2								ERd32-1 → ERd32	—	—	—	—	—	—	2	
SUBS.L #2, ERd	L	2								ERd32-2 → ERd32	—	—	—	—	—	—	2	
SUBS.L #4, ERd	L	2								ERd32-4 → ERd32	—	—	—	—	—	—	2	
DEC.B Rd	B	2								Rd8-1 → Rd8	—	—	↓	↓	↓	—	2	
DEC.W #1, Rd	W	2								Rd16-1 → Rd16	—	—	↓	↓	↓	—	2	
DEC.W #2, Rd	W	2								Rd16-2 → Rd16	—	—	↓	↓	↓	—	2	
DEC.L #1, ERd	L	2								ERd32-1 → ERd32	—	—	↓	↓	↓	—	2	
DEC.L #2, ERd	L	2								ERd32-2 → ERd32	—	—	↓	↓	↓	—	2	
DAS.Rd	B	2								Rd8 decimal adjust → Rd8	—	*	↓	↓	*	—	2	
MULXU.B Rs, Rd	B	2								Rd8 × Rs8 → Rd16 (unsigned multiplication)	—	—	—	—	—	—	14	
MULXU.W Rs, ERd	W	2								Rd16 × Rs16 → ERd32 (unsigned multiplication)	—	—	—	—	—	—	22	
MULXS.B Rs, Rd	B	4								Rd8 × Rs8 → Rd16 (signed multiplication)	—	—	↓	↓	—	—	16	
MULXS.W Rs, ERd	W	4								Rd16 × Rs16 → ERd32 (signed multiplication)	—	—	↓	↓	—	—	24	
DIVXU.B Rs, Rd	B	2								Rd16 ÷ Rs8 → Rd16 (RdH: remainder, RdL: quotient) (unsigned division)	—	—	(6)	(7)	—	—	14	

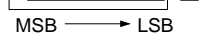
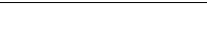
Mnemonic	Operand Size	Addressing Mode and Instruction Length (bytes)								Operation	Condition Code						No. of States *1	
		#xx	Rn	@ERn	@(d, ERn)	@-ERn/@ERn+	@aa	@(d, PC)	@@aa		I	H	N	Z	V	C	Normal	Advanced
DIVXU.W Rs, ERd	W	2								ERd32 + Rs16 → ERd32 (Ed: remainder, Rd: quotient) (unsigned division)	—	—	(6)	(7)	—	—	22	
DIVXS.B Rs, Rd	B	4								Rd16 ÷ Rs8 → Rd16 (RdH: remainder, RdL: quotient) (signed division)	—	—	(8)	(7)	—	—	16	
DIVXS.W Rs, ERd	W	4								ERd32 ÷ Rs16 → ERd32 (Ed: remainder, Rd: quotient) (signed division)	—	—	(8)	(7)	—	—	24	
CMP.B #xx:8, Rd	B	2								Rd8-#xx:8	—	⇕	⇕	⇕	⇕	⇕	2	
CMP.B Rs, Rd	B	2								Rd8-Rs8	—	⇕	⇕	⇕	⇕	⇕	2	
CMP.W #xx:16, Rd	W	4								Rd16-#xx:16	—	(1)	⇕	⇕	⇕	⇕	4	
CMP.W Rs, Rd	W	2								Rd16-Rs16	—	(1)	⇕	⇕	⇕	⇕	2	
CMP.L #xx:32, ERd	L	6								ERd32-#xx:32	—	(2)	⇕	⇕	⇕	⇕	6	
CMP.L ERs, ERd	L	2								ERd32-ERs32	—	(2)	⇕	⇕	⇕	⇕	2	
NEG.B Rd	B	2								0-Rd8 → Rd8	—	⇕	⇕	⇕	⇕	⇕	2	
NEG.W Rd	W	2								0-Rd16 → Rd16	—	⇕	⇕	⇕	⇕	⇕	2	
NEG.L ERd	L	2								0-ERd32 → ERd32	—	⇕	⇕	⇕	⇕	⇕	2	
EXTU.W Rd	W	2								0 → (<bits 15 to 8> of Rd16)	—	—	0	⇕	0	—	2	
EXTU.L ERd	L	2								0 → (<bits 31 to 16> of ERd32)	—	—	0	⇕	0	—	2	
EXTS.W Rd	W	2								(<bit 7> of Rd16) → (<bits 15 to 8> of Rd16)	—	—	⇕	⇕	0	—	2	
EXTS.L ERd	L	2								(<bit 15> of ERd32) → (<bits 31 to 16> of ERd32)	—	—	⇕	⇕	0	—	2	

4. Shift instructions

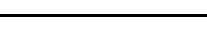
Mnemonic	Operand Size	Addressing Mode and Instruction Length (bytes)								Operation	Condition Code						No. of States ^{*1}	
		#xx	Rn	@ERn	@(d, ERn)	@-ERn/@ERn+	@aa	@(d, PC)	@@aa		I	H	N	Z	V	C	Normal	Advanced
SHAL.B Rd	B	2									—	—	↑	↑	↑	↑	2	
SHAL.W Rd	W	2									—	—	↑	↑	↑	↑	2	
SHAL.L ERd	L	2									—	—	↑	↑	↑	↑	2	
SHAR.B Rd	B	2									—	—	↑	↑	0	↑	2	
SHAR.W Rd	W	2									—	—	↑	↑	0	↑	2	
SHAR.L ERd	L	2									—	—	↑	↑	0	↑	2	
SHLL.B Rd	B	2									—	—	↑	↑	0	↑	2	
SHLL.W Rd	W	2									—	—	↑	↑	0	↑	2	
SHLL.L ERd	L	2									—	—	↑	↑	0	↑	2	
SHLR.B Rd	B	2									—	—	↑	↑	0	↑	2	
SHLR.W Rd	W	2									—	—	↑	↑	0	↑	2	
SHLR.L ERd	L	2									—	—	↑	↑	0	↑	2	
ROTXL.B Rd	B	2									—	—	↑	↑	0	↑	2	
ROTXL.W Rd	W	2									—	—	↑	↑	0	↑	2	
ROTXL.L ERd	L	2									—	—	↑	↑	0	↑	2	
ROTXR.B Rd	B	2									—	—	↑	↑	0	↑	2	
ROTXR.W Rd	W	2									—	—	↑	↑	0	↑	2	
ROTXR.L ERd	L	2									—	—	↑	↑	0	↑	2	
ROTL.B Rd	B	2									—	—	↑	↑	0	↑	2	
ROTL.W Rd	W	2									—	—	↑	↑	0	↑	2	
ROTL.L ERd	L	2									—	—	↑	↑	0	↑	2	
ROTR.B Rd	B	2									—	—	↑	↑	0	↑	2	
ROTR.W Rd	W	2									—	—	↑	↑	0	↑	2	
ROTR.L ERd	L	2									—	—	↑	↑	0	↑	2	

5. Bit manipulation instructions

Mnemonic	Operand Size	Addressing Mode and Instruction Length (bytes)								Operation	Condition Code						No. of States*1		
		#xx	Rn	@ERn	@ (d, ERn)	@-ERn/@ERn+	@aa	@ (d, PC)	@ @aa			Condition Code						Normal	Advanced
												I	H	N	Z	V	C		
BSET #xx:3, Rd	B	2																2	
BSET #xx:3, @ERd	B		4															8	
BSET #xx:3, @aa:8	B					4												8	
BSET Rn, Rd	B	2																2	
BSET Rn, @ERd	B		4															8	
BSET Rn, @aa:8	B					4												8	
BCLR #xx:3, Rd	B	2																2	
BCLR #xx:3, @ERd	B		4															8	
BCLR #xx:3, @aa:8	B					4												8	
BCLR Rn, Rd	B	2																2	
BCLR Rn, @ERd	B		4															8	
BCLR Rn, @aa:8	B					4												8	
BNOT #xx:3, Rd	B	2																2	
BNOT #xx:3, @ERd	B		4															8	
BNOT #xx:3, @aa:8	B					4												8	
BNOT Rn, Rd	B	2																2	
BNOT Rn, @ERd	B		4															8	
BNOT Rn, @aa:8	B					4												8	
BTST #xx:3, Rd	B	2																2	
BTST #xx:3, @ERd	B		4															6	
BTST #xx:3, @aa:8	B					4												6	
BTST Rn, Rd	B	2																2	
BTST Rn, @ERd	B		4															6	
BTST Rn, @aa:8	B					4												6	
BLD #xx:3, Rd	B	2																2	

Mnemonic	Operand Size	Addressing Mode and Instruction Length (bytes)								Operation	Condition Code						No. of States ^{*1}	
		#xx	Rn	@ERn	@ (d, ERn)	@-ERn/@ERn+	@aa	@ (d, PC)	@@aa		I	H	N	Z	V	C	Normal	Advanced
BLD #xx:3, @ERd	B		4												↕	6		
BLD #xx:3, @aa:8	B					4									↕	6		
BILD #xx:3, Rd	B	2													↕	2		
BILD #xx:3, @ERd	B		4												↕	6		
BILD #xx:3, @aa:8	B					4									↕	6		
BST #xx:3, Rd	B	2														2		
BST #xx:3, @ERd	B		4													8		
BST #xx:3, @aa:8	B					4										8		
BIST #xx:3, Rd	B	2														2		
BIST #xx:3, @ERd	B		4													8		
BIST #xx:3, @aa:8	B					4										8		
BAND #xx:3, Rd	B	2													↕	2		
BAND #xx:3, @ERd	B		4												↕	6		
BAND #xx:3, @aa:8	B					4									↕	6		
BIAND #xx:3, Rd	B	2													↕	2		
BIAND #xx:3, @ERd	B		4												↕	6		
BIAND #xx:3, @aa:8	B					4									↕	6		
BOR #xx:3, Rd	B	2													↕	2		
BOR #xx:3, @ERd	B		4												↕	6		
BOR #xx:3, @aa:8	B					4									↕	6		
BIOR #xx:3, Rd	B	2													↕	2		
BIOR #xx:3, @ERd	B		4												↕	6		
BIOR #xx:3, @aa:8	B					4									↕	6		
BXOR #xx:3, Rd	B	2													↕	2		
BXOR #xx:3, @ERd	B		4												↕	6		
BXOR #xx:3, @aa:8	B					4									↕	6		
BIXOR #xx:3, Rd	B	2													↕	2		
BIXOR #xx:3, @ERd	B		4												↕	6		
BIXOR #xx:3, @aa:8	B					4									↕	6		

6. Branching instructions

Mnemonic	Operand Size	Addressing Mode and Instruction Length (bytes)								Operation	Branch Condition	Condition Code						No. of States ^{*1}		
		#xx	Rn	@ ERn	@ (d, ERn)	@ -ERn/@ ERn+	@ aa	@ (d, PC)	@ @aa			I	I	H	N	Z	V	C	Normal	Advanced
BRA d:8 (BT d:8)	—								2		If condition is true then PC ← PC+d else next;	Always	—	—	—	—	—	—	4	
BRA d:16 (BT d:16)	—							4						—	—	—	—	—	—	6
BRN d:8 (BF d:8)	—								2		Never	Never	—	—	—	—	—	—	4	
BRN d:16 (BF d:16)	—							4							—	—	—	—	—	6
BHI d:8	—								2		C ∨ Z = 0	C ∨ Z = 0	—	—	—	—	—	—	4	
BHI d:16	—							4							—	—	—	—	—	6
BLS d:8	—								2		C ∨ Z = 1	C ∨ Z = 1	—	—	—	—	—	—	4	
BLS d:16	—							4							—	—	—	—	—	6
BCC d:8 (BHS d:8)	—								2		C = 0	C = 0	—	—	—	—	—	—	4	
BCC d:16 (BHS d:16)	—							4							—	—	—	—	—	6
BCS d:8 (BLO d:8)	—								2		C = 1	C = 1	—	—	—	—	—	—	4	
BCS d:16 (BLO d:16)	—							4							—	—	—	—	—	6
BNE d:8	—								2		Z = 0	Z = 0	—	—	—	—	—	—	4	
BNE d:16	—							4							—	—	—	—	—	6
BEQ d:8	—								2		Z = 1	Z = 1	—	—	—	—	—	—	4	
BEQ d:16	—							4							—	—	—	—	—	6
BVC d:8	—								2		V = 0	V = 0	—	—	—	—	—	—	4	
BVC d:16	—							4							—	—	—	—	—	6
BVS d:8	—								2		V = 1	V = 1	—	—	—	—	—	—	4	
BVS d:16	—							4							—	—	—	—	—	6
BPL d:8	—								2		N = 0	N = 0	—	—	—	—	—	—	4	
BPL d:16	—							4							—	—	—	—	—	6
BMI d:8	—								2		N = 1	N = 1	—	—	—	—	—	—	4	
BMI d:16	—							4							—	—	—	—	—	6
BGE d:8	—								2		N ⊕ V = 0	N ⊕ V = 0	—	—	—	—	—	—	4	
BGE d:16	—							4							—	—	—	—	—	6
BLT d:8	—								2		N ⊕ V = 1	N ⊕ V = 1	—	—	—	—	—	—	4	
BLT d:16	—							4							—	—	—	—	—	6
BGT d:8	—								2		Z ∨ (N ⊕ V) = 0	Z ∨ (N ⊕ V) = 0	—	—	—	—	—	—	4	
BGT d:16	—							4							—	—	—	—	—	6

Mnemonic	Operand Size	Addressing Mode and Instruction Length (bytes)								Operation	Branch Condition	Condition Code						No. of States ^{*1}	
		#xx	Rn	@ERn	@(d, ERn)	@-ERn/@ERn+	@aa	@(d, PC)	@@aa			I	H	N	Z	V	C	Normal	Advanced
BLE d:8	—							2		If condition is true then PC ← PC+d else next;	Z ∨ (N∧V) = 1	—	—	—	—	—	—	4	
BLE d:16	—						4		—			—	—	—	—	—	—	6	
JMP @ERn	—			2						PC ← ERn		—	—	—	—	—	—	4	
JMP @aa:24	—						4			PC ← aa:24		—	—	—	—	—	—	6	
JMP @@aa:8	—							2		PC ← @aa:8		—	—	—	—	—	—	8	10
BSR d:8	—							2		PC → @-SP PC ← PC+d:8		—	—	—	—	—	—	6	8
BSR d:16	—							4		PC → @-SP PC ← PC+d:16		—	—	—	—	—	—	8	10
JSR @ERn	—			2						PC → @-SP PC ← @ERn		—	—	—	—	—	—	6	8
JSR @aa:24	—						4			PC → @-SP PC ← @aa:24		—	—	—	—	—	—	8	10
JSR @@aa:8	—							2		PC → @-SP PC ← @aa:8		—	—	—	—	—	—	8	12
RTS	—							2		PC ← @SP+								8	10

7. System control instructions

Mnemonic	Operand Size	Addressing Mode and Instruction Length (bytes)								Operation	Condition Code						No. of States ^{*1}		
		#xx	Rn	@ERn	@ (d, ERn)	@-ERn/@ERn+	@aa	@ (d, PC)	@ @aa		l	I	H	N	Z	V	C	Normal	Advanced
TRAPA #x:2	—									2	PC → @-SP CCR → @-SP <vector> → PC	1	—	—	—	—	—	14	16
RTE	—										CCR ← @SP+ PC ← @SP+	↓	↓	↓	↓	↓	↓	10	
SLEEP	—										Transition to powerdown state	—	—	—	—	—	—	2	
LDC #xx:8, CCR	B	2									#xx:8 → CCR	↓	↓	↓	↓	↓	↓	2	
LDC Rs, CCR	B		2								Rs8 → CCR	↓	↓	↓	↓	↓	↓	2	
LDC @ERs, CCR	W			4							@ERs → CCR	↓	↓	↓	↓	↓	↓	6	
LDC @ (d:16, ERs), CCR	W				6						@ (d:16, ERs) → CCR	↓	↓	↓	↓	↓	↓	8	
LDC @ (d:24, ERs), CCR	W				10						@ (d:24, ERs) → CCR	↓	↓	↓	↓	↓	↓	12	
LDC @ERs+, CCR	W					4					@ERs → CCR ERs32+2 → ERs32	↓	↓	↓	↓	↓	↓	8	
LDC @aa:16, CCR	W						6				@aa:16 → CCR	↓	↓	↓	↓	↓	↓	8	
LDC @aa:24, CCR	W							8			@aa:24 → CCR	↓	↓	↓	↓	↓	↓	10	
STC CCR, Rd	B		2								CCR → Rd8	—	—	—	—	—	—	2	
STC CCR, @ERd	W			4							CCR → @ERd	—	—	—	—	—	—	6	
STC CCR, @ (d:16, ERd)	W				6						CCR → @ (d:16, ERd)	—	—	—	—	—	—	8	
STC CCR, @ (d:24, ERd)	W				10						CCR → @ (d:24, ERd)	—	—	—	—	—	—	12	
STC CCR, @-ERd	W					4					ERd32-2 → ERd32 CCR → @ERd	—	—	—	—	—	—	8	
STC CCR, @aa:16	W						6				CCR → @aa:16	—	—	—	—	—	—	8	
STC CCR, @aa:24	W							8			CCR → @aa:24	—	—	—	—	—	—	10	
ANDC #xx:8, CCR	B	2									CCR^#xx:8 → CCR	↓	↓	↓	↓	↓	↓	2	
ORC #xx:8, CCR	B	2									CCR v #xx:8 → CCR	↓	↓	↓	↓	↓	↓	2	
XORC #xx:8, CCR	B	2									CCR @ #xx:8 → CCR	↓	↓	↓	↓	↓	↓	2	
NOP	—									2	PC ← PC+2	—	—	—	—	—	—	2	

8. Block transfer instructions

Mnemonic	Operand Size	Addressing Mode and Instruction Length (bytes)								Operation	Condition Code						No. of States ^{*1}		
		#xx	Rn	@ERn	@ (d, ERn)	@-ERn/@ERn+	@aa	@ (d, PC)	@@aa			I	H	N	Z	V	C	Normal	Advanced
EEPMOV. B	—									4	if R4L ≠ 0 repeat @R5 → @R6 R5+1 → R5 R6+1 → R6 R4L-1 → R4L until R4L=0 else next;	—	—	—	—	—	—	8+ 4n ^{*2}	
EEPMOV. W	—									4	if R4 ≠ 0 repeat @R5 → @R6 R5+1 → R5 R6+1 → R6 R4-1 → R4 until R4=0 else next;	—	—	—	—	—	—	8+ 4n ^{*2}	

Notes: 1. The number of states is the number of states required for execution when the instruction and its operands are located in on-chip memory. For other cases see section A.3, Number of States Required for Execution.

2. n is the value set in register R4L or R4.

(1) Set to 1 when a carry or borrow occurs at bit 11; otherwise cleared to 0.

(2) Set to 1 when a carry or borrow occurs at bit 27; otherwise cleared to 0.

(3) Retains its previous value when the result is zero; otherwise cleared to 0.

(4) Set to 1 when the adjustment produces a carry; otherwise retains its previous value.

(5) The number of states required for execution of an instruction that transfers data in synchronization with the E clock is variable.

(6) Set to 1 when the divisor is negative; otherwise cleared to 0.

(7) Set to 1 when the divisor is zero; otherwise cleared to 0.

(8) Set to 1 when the quotient is negative; otherwise cleared to 0.

A.2 Operation Code Maps

Table A.2 Operation Code Map (1)

Instruction code:		1st byte		2nd byte		Instruction when most significant bit of BH is 0.											Instruction when most significant bit of BH is 1.										
		AH	AL	AH	AL	BH	BL	0	1	2	3	4	5	6	7	8	9	A	B	C	D	E	F				
AH	AL																										
0	0	NOP	Table A.2 (2)	STC	LDC	ORC	XORC	ANDC	LDC	LDC	ADD	Table A.2 (2)	Table A.2 (2)	Table A.2 (2)	Table A.2 (2)	Table A.2 (2)	Table A.2 (2)	Table A.2 (2)	Table A.2 (2)	Table A.2 (2)	Table A.2 (2)	Table A.2 (2)	Table A.2 (2)				
1	1	Table A.2 (2)	Table A.2 (2)	Table A.2 (2)	OR.B	OR.B	XOR.B	AND.B	Table A.2 (2)	Table A.2 (2)	SUB	Table A.2 (2)	Table A.2 (2)	Table A.2 (2)	Table A.2 (2)	Table A.2 (2)	Table A.2 (2)	Table A.2 (2)	Table A.2 (2)	Table A.2 (2)	Table A.2 (2)	Table A.2 (2)	Table A.2 (2)				
2	2	MOV.B																									
3	3																										
4	4	BRA	BRN	BHI	BLS	BCC	BCS	BNE	BNQ	BVC	BVS	BPL	BMI	BGE	BLT	BGT	BLE										
5	5	MULXU	DIVXU	MULXU	DIVXU	RTS	BSR	RTE	TRAPA	Table A.2 (2)		JMP		BSR		JSR											
6	6	BSET	BNOT	BCLR	BTST		OR	AND	BST																		
7	7					BOR	BXOR	BAND	BLD	BIOR	BIXOR	BIAND	BIOR	BIAND	BILD	MOV	Table A.2 (2)	Table A.2 (2)	Table A.2 (2)	Table A.2 (2)	Table A.2 (2)	Table A.2 (2)	Table A.2 (2)				
8	8	ADD																									
9	9	ADDX																									
A	A	CMP																									
B	B	SUBX																									
C	C	OR																									
D	D	XOR																									
E	E	AND																									
F	F	MOV																									

Table A.2 Operation Code Map (2)



Instruction code:

BH AH	0	1	2	3	4	5	6	7	8	9	A	B	C	D	E	F
01	MOV				LDC/STC				SLEEP				Table A.2 (3)	Table A.2 (3)		Table A.2 (3)
0A	INC	ADD														
0B	ADDS					INC		INC	ADDS					INC		INC
0F	DAA	MOV														
10	SHLL				SHLL				SHAL							SHAL
11	SHLR				SHLR				SHAR							SHAR
12	ROTXL				ROTXL				ROTL							ROTL
13	ROTXR				ROTXR				ROTR							ROTR
17	NOT				NOT			EXTU	NEG							EXTS
1A	DEC	SUB														
1B	SUBS					DEC		DEC	SUBS							DEC
1F	DAS	CMP														
58	BRA	BRN	BHI	BLS	BCC	BCS	BNE	BEQ	BVC	BVS	BPL	BMI	BGE	BLT	BGT	BLE
79	MOV	ADD	CMP	SUB	OR	XOR	AND									
7A	MOV	ADD	CMP	SUB	OR	XOR	AND									

Table A.2 Operation Code Map (3)

Instruction code:

1st byte		2nd byte		3rd byte		4th byte																											
AH	AL	BH	BL	CH	CL	DH	DL																										
CL		0		1		2		3		4		5		6		7		8		9		A		B		C		D		E		F	

Instruction when most significant bit of DH is 0.

Instruction when most significant bit of DH is 1.

CL	0	1	2	3	4	5	6	7	8	9	A	B	C	D	E	F
AH ALBH BLCH	MULXS		MULXS		OR		XOR		AND		DIVXS		DIVXS		BTST	
01C05	MULXS		MULXS		OR		XOR		AND		DIVXS		DIVXS		BTST	
01D05	MULXS		MULXS		OR		XOR		AND		DIVXS		DIVXS		BTST	
01F06	MULXS		MULXS		OR		XOR		AND		DIVXS		DIVXS		BTST	
7C06 *1	MULXS		MULXS		OR		XOR		AND		DIVXS		DIVXS		BTST	
7C07 *1	MULXS		MULXS		OR		XOR		AND		DIVXS		DIVXS		BTST	
7D06 *1	MULXS		MULXS		OR		XOR		AND		DIVXS		DIVXS		BTST	
7D07 *1	MULXS		MULXS		OR		XOR		AND		DIVXS		DIVXS		BTST	
7Eaa6 *2	MULXS		MULXS		OR		XOR		AND		DIVXS		DIVXS		BTST	
7Eaa7 *2	MULXS		MULXS		OR		XOR		AND		DIVXS		DIVXS		BTST	
7Faa6 *2	MULXS		MULXS		OR		XOR		AND		DIVXS		DIVXS		BTST	
7Faa7 *2	MULXS		MULXS		OR		XOR		AND		DIVXS		DIVXS		BTST	

Notes: 1. r is the register designation field.
2. aa is the absolute address field.

A.3 Number of States Required for Execution

The tables in this section can be used to calculate the number of states required for instruction execution by the H8/300H CPU. Table A.4 indicates the number of instruction fetch, data read/write, and other cycles occurring in each instruction. Table A.3 indicates the number of states required per cycle according to the bus size. The number of states required for execution of an instruction can be calculated from these two tables as follows:

$$\text{Number of states} = I \times S_I + J \times S_J + K \times S_K + L \times S_L + M \times S_M + N \times S_N$$

Examples of Calculation of Number of States Required for Execution

Examples: Advanced mode, stack located in external address space, on-chip supporting modules accessed with 8-bit bus width, external devices accessed in three states with one wait state and 16-bit bus width.

BSET #0, @FFFFC7:8

From table A.4, $I = L = 2$ and $J = K = M = N = 0$

From table A.3, $S_I = 4$ and $S_L = 3$

$$\text{Number of states} = 2 \times 4 + 2 \times 3 = 14$$

JSR @@30

From table A.4, $I = J = K = 2$ and $L = M = N = 0$

From table A.3, $S_I = S_J = S_K = 4$

$$\text{Number of states} = 2 \times 4 + 2 \times 4 + 2 \times 4 = 24$$

Table A.3 Number of States per Cycle

Execution State (Cycle)	On-Chip Memory	Access Conditions						
		On-Chip Sup- porting Module		External Device				
		8-Bit Bus	16-Bit Bus	8-Bit Bus		16-Bit Bus		
				2-State Access	3-State Access	2-State Access	3-State Access	
Instruction fetch	S _I	2	6	3	4	6 + 2m	2	3 + m
Branch address read	S _J							
Stack operation	S _K							
Byte data access	S _L		3		2	3 + m		
Word data access	S _M		6		4	6 + 2m		
Internal operation	S _N	1						

Legend

m: Number of wait states inserted into external device access

Table A.4 Number of Cycles per Instruction

Instruction	Mnemonic	Instruction	Branch	Stack	Byte Data	Word Data	Internal
		Fetch	Addr. Read	Operation	Access	Access	Operation
		I	J	K	L	M	N
ADD	ADD.B #xx:8, Rd	1					
	ADD.B Rs, Rd	1					
	ADD.W #xx:16, Rd	2					
	ADD.W Rs, Rd	1					
	ADD.L #xx:32, ERd	3					
	ADD.L ERs, ERd	1					
ADDS	ADDS #1/2/4, ERd	1					
ADDX	ADDX #xx:8, Rd	1					
	ADDX Rs, Rd	1					
AND	AND.B #xx:8, Rd	1					
	AND.B Rs, Rd	1					
	AND.W #xx:16, Rd	2					
	AND.W Rs, Rd	1					
	AND.L #xx:32, ERd	3					
	AND.L ERs, ERd	2					
ANDC	ANDC #xx:8, CCR	1					
BAND	BAND #xx:3, Rd	1					
	BAND #xx:3, @ERd	2			1		
	BAND #xx:3, @aa:8	2			1		
Bcc	BRA d:8 (BT d:8)	2					
	BRN d:8 (BF d:8)	2					
	BHI d:8	2					
	BLS d:8	2					
	BCC d:8 (BHS d:8)	2					
	BCS d:8 (BLO d:8)	2					
	BNE d:8	2					
	BEQ d:8	2					
	BVC d:8	2					
	BVS d:8	2					
	BPL d:8	2					
	BMI d:8	2					
	BGE d:8	2					
	BLT d:8	2					
	BGT d:8	2					
	BLE d:8	2					

Instruction	Mnemonic	Instruction	Branch	Stack	Byte Data	Word Data	Internal
		Fetch	Addr. Read	Operation	Access	Access	Operation
		I	J	K	L	M	N
Bcc	BRA d:16 (BT d:16)	2					2
	BRN d:16 (BF d:16)	2					2
	BHI d:16	2					2
	BLS d:16	2					2
	BCC d:16 (BHS d:16)	2					2
	BCS d:16 (BLO d:16)	2					2
	BNE d:16	2					2
	BEQ d:16	2					2
	BVC d:16	2					2
	BVS d:16	2					2
	BPL d:16	2					2
	BMI d:16	2					2
	BGE d:16	2					2
	BLT d:16	2					2
BGT d:16	2					2	
BLE d:16	2					2	
BCLR	BCLR #xx:3, Rd	1					
	BCLR #xx:3, @ERd	2			2		
	BCLR #xx:3, @aa:8	2			2		
	BCLR Rn, Rd	1					
	BCLR Rn, @ERd	2			2		
	BCLR Rn, @aa:8	2			2		
BIAND	BIAND #xx:3, Rd	1					
	BIAND #xx:3, @ERd	2			1		
	BIAND #xx:3, @aa:8	2			1		
BILD	BILD #xx:3, Rd	1					
	BILD #xx:3, @ERd	2			1		
	BILD #xx:3, @aa:8	2			1		
BIOR	BIOR #xx:8, Rd	1					
	BIOR #xx:8, @ERd	2			1		
	BIOR #xx:8, @aa:8	2			1		
BIST	BIST #xx:3, Rd	1					
	BIST #xx:3, @ERd	2			2		
	BIST #xx:3, @aa:8	2			2		
BIXOR	BIXOR #xx:3, Rd	1					
	BIXOR #xx:3, @ERd	2			1		
	BIXOR #xx:3, @aa:8	2			1		
BLD	BLD #xx:3, Rd	1					
	BLD #xx:3, @ERd	2			1		
	BLD #xx:3, @aa:8	2			1		

Instruction	Mnemonic	Instruction		Branch	Stack	Byte Data	Word Data	Internal
		Fetch	Branch	Addr. Read	Operation	Access	Access	Operation
		I	J	K	L	M	N	
BNOT	BNOT #xx:3, Rd	1						
	BNOT #xx:3, @ERd	2			2			
	BNOT #xx:3, @aa:8	2			2			
	BNOT Rn, Rd	1						
	BNOT Rn, @ERd	2			2			
	BNOT Rn, @aa:8	2			2			
BOR	BOR #xx:3, Rd	1						
	BOR #xx:3, @ERd	2			1			
	BOR #xx:3, @aa:8	2			1			
BSET	BSET #xx:3, Rd	1						
	BSET #xx:3, @ERd	2			2			
	BSET #xx:3, @aa:8	2			2			
	BSET Rn, Rd	1						
	BSET Rn, @ERd	2			2			
	BSET Rn, @aa:8	2			2			
BSR	BSR d:8	Normal	2		1			
		Advanced	2		2			
	BSR d:16	Normal	2		1			2
		Advanced	2		2			2
BST	BST #xx:3, Rd	1						
	BST #xx:3, @ERd	2			2			
	BST #xx:3, @aa:8	2			2			
BTST	BTST #xx:3, Rd	1						
	BTST #xx:3, @ERd	2			1			
	BTST #xx:3, @aa:8	2			1			
	BTST Rn, Rd	1						
	BTST Rn, @ERd	2			1			
	BTST Rn, @aa:8	2			1			
BXOR	BXOR #xx:3, Rd	1						
	BXOR #xx:3, @ERd	2			1			
	BXOR #xx:3, @aa:8	2			1			
CMP	CMP.B #xx:8, Rd	1						
	CMP.B Rs, Rd	1						
	CMP.W #xx:16, Rd	2						
	CMP.W Rs, Rd	1						
	CMP.L #xx:32, ERd	3						
	CMP.L ERs, ERd	1						
DAA	DAA Rd	1						
DAS	DAS Rd	1						

Instruction Mnemonic		Instruction	Branch	Stack	Byte Data	Word Data	Internal	
		Fetch	Addr. Read	Operation	Access	Access	Operation	
		I	J	K	L	M	N	
DEC	DEC.B Rd	1						
	DEC.W #1/2, Rd	1						
	DEC.L #1/2, ERd	1						
DIVXS	DIVXS.B Rs, Rd	2					12	
	DIVXS.W Rs, ERd	2					20	
DIVXU	DIVXU.B Rs, Rd	1					12	
	DIVXU.W Rs, ERd	1					20	
EEPMOV	EEPMOV.B	2			$2n + 2^{*1}$			
	EEPMOV.W	2			$2n + 2^{*1}$			
EXTS	EXTS.W Rd	1						
	EXTS.L ERd	1						
EXTU	EXTU.W Rd	1						
	EXTU.L ERd	1						
INC	INC.B Rd	1						
	INC.W #1/2, Rd	1						
	INC.L #1/2, ERd	1						
JMP	JMP @ERn	2						
	JMP @aa:24	2					2	
	JMP @@aa:8	Normal	2	1				2
		Advanced	2	2				2
JSR	JSR @ERn	Normal	2		1			
		Advanced	2		2			
	JSR @aa:24	Normal	2		1		2	
		Advanced	2		2		2	
	JSR @@aa:8	Normal	2	1	1			
		Advanced	2	2	2			
	LDC	LDC #xx:8, CCR	1					
		LDC Rs, CCR	1					
LDC @ERs, CCR		2				1		
LDC @(d:16, ERs), CCR		3				1		
LDC @(d:24, ERs), CCR		5				1		
LDC @ERs+, CCR		2				1	2	
LDC @aa:16, CCR		3				1		
LDC @aa:24, CCR		4				1		

Instruction Mnemonic		Instruction	Branch	Stack	Byte Data	Word Data	Internal	
		Fetch	Addr. Read	Operation	Access	Access	Operation	
		I	J	K	L	M	N	
MOV	MOV.B #xx:8, Rd	1						
	MOV.B Rs, Rd	1						
	MOV.B @ERs, Rd	1			1			
	MOV.B @(d:16, ERs), Rd	2			1			
	MOV.B @(d:24, ERs), Rd	4			1			
	MOV.B @ERs+, Rd	1			1		2	
	MOV.B @aa:8, Rd	1			1			
	MOV.B @aa:16, Rd	2			1			
	MOV.B @aa:24, Rd	3			1			
	MOV.B Rs, @ERd	1			1			
	MOV.B Rs, @(d:16, ERd)	2			1			
	MOV.B Rs, @(d:24, ERd)	4			1			
	MOV.B Rs, @-ERd	1			1		2	
	MOV.B Rs, @aa:8	1			1			
	MOV.B Rs, @aa:16	2			1			
	MOV.B Rs, @aa:24	3			1			
	MOV.W #xx:16, Rd	2						
	MOV.W Rs, Rd	1						
	MOV.W @ERs, Rd	1					1	
	MOV.W @(d:16, ERs), Rd	2					1	
	MOV.W @(d:24, ERs), Rd	4					1	
	MOV.W @ERs+, Rd	1					1	2
	MOV.W @aa:16, Rd	2					1	
	MOV.W @aa:24, Rd	3					1	
	MOV.W Rs, @ERd	1					1	
	MOV.W Rs, @(d:16, ERd)	2					1	
	MOV.W Rs, @(d:24, ERd)	4					1	
	MOV.W Rs, @-ERd	1					1	2
	MOV.W Rs, @aa:16	2					1	
	MOV.W Rs, @aa:24	3					1	
	MOV.L #xx:32, ERd	3						
	MOV.L ERs, ERd	1						
	MOV.L @ERs, ERd	2					2	
	MOV.L @(d:16, ERs), ERd	3					2	
	MOV.L @(d:24, ERs), ERd	5					2	
	MOV.L @ERs+, ERd	2					2	2
MOV.L @aa:16, ERd	3					2		
MOV.L @aa:24, ERd	4					2		
MOV.L ERs, @ERd	2					2		
MOV.L ERs, @(d:16, ERd)	3					2		
MOV.L ERs, @(d:24, ERd)	5					2		
MOV.L ERs, @-ERd	2					2	2	
MOV.L ERs, @aa:16	3					2		
MOV.L ERs, @aa:24	4					2		

Instruction	Mnemonic	Instruction	Branch	Stack	Byte Data	Word Data	Internal
		Fetch	Addr. Read	Operation	Access	Access	Operation
		I	J	K	L	M	N
MOVFP	MOVFP @aa:16, Rd*2				1		
MOVTP	MOVTP Rs, @aa:16*2				1		
MULXS	MULXS.B Rs, Rd	2					12
	MULXS.W Rs, ERd	2					20
MULXU	MULXU.B Rs, Rd	1					12
	MULXU.W Rs, ERd	1					20
NEG	NEG.B Rd	1					
	NEG.W Rd	1					
	NEG.L ERd	1					
NOP	NOP	1					
NOT	NOT.B Rd	1					
	NOT.W Rd	1					
	NOT.L ERd	1					
OR	OR.B #xx:8, Rd	1					
	OR.B Rs, Rd	1					
	OR.W #xx:16, Rd	2					
	OR.W Rs, Rd	1					
	OR.L #xx:32, ERd	3					
	OR.L ERs, ERd	2					
ORC	ORC #xx:8, CCR	1					
POP	POP.W Rn	1				1	2
	POP.L ERn	2				2	2
PUSH	PUSH.W Rn	1				1	2
	PUSH.L ERn	2				2	2
ROTL	ROTL.B Rd	1					
	ROTL.W Rd	1					
	ROTL.L ERd	1					
ROTR	ROTR.B Rd	1					
	ROTR.W Rd	1					
	ROTR.L ERd	1					
ROTXL	ROTXL.B Rd	1					
	ROTXL.W Rd	1					
	ROTXL.L ERd	1					
ROTXR	ROTXR.B Rd	1					
	ROTXR.W Rd	1					
	ROTXR.L ERd	1					
RTE	RTE	2		2		2	

Instruction	Mnemonic		Instruction	Branch	Stack	Byte Data	Word Data	Internal
			Fetch	Addr. Read	Operation	Access	Access	Operation
			I	J	K	L	M	N
RTS	RTS	Normal	2		1			2
		Advanced	2		2			2
SHAL	SHAL.B Rd		1					
	SHAL.W Rd		1					
	SHAL.L ERd		1					
SHAR	SHAR.B Rd		1					
	SHAR.W Rd		1					
	SHAR.L ERd		1					
SHLL	SHLL.B Rd		1					
	SHLL.W Rd		1					
	SHLL.L ERd		1					
SHLR	SHLR.B Rd		1					
	SHLR.W Rd		1					
	SHLR.L ERd		1					
SLEEP	SLEEP		1					
STC	STC CCR, Rd		1					
	STC CCR, @ERd		2				1	
	STC CCR, @(d:16, ERd)		3				1	
	STC CCR, @(d:24, ERd)		5				1	
	STC CCR, @-ERd		2				1	2
	STC CCR, @aa:16		3				1	
	STC CCR, @aa:24		4				1	
SUB	SUB.B Rs, Rd		1					
	SUB.W #xx:16, Rd		2					
	SUB.W Rs, Rd		1					
	SUB.L #xx:32, ERd		3					
	SUB.L ERs, ERd		1					
SUBS	SUBS #1/2/4, ERd		1					
SUBX	SUBX #xx:8, Rd		1					
	SUBX Rs, Rd		1					
TRAPA	TRAPA #x:2	Normal	2	1	2			4
		Advanced	2	2	2			4
XOR	XOR.B #xx:8, Rd		1					
	XOR.B Rs, Rd		1					
	XOR.W #xx:16, Rd		2					
	XOR.W Rs, Rd		1					
	XOR.L #xx:32, ERd		3					
	XOR.L ERs, ERd		2					
XORC	XORC #xx:8, CCR		1					

Notes: 1. n is the value set in register R4L or R4. The source and destination are accessed n + 1 times each.

2. Not available in the H8/3067 Group.

Appendix B Internal I/O Registers

B.1 Addresses (EMC = 1)

Address (Low)	Register Name	Data Bus Width	Bit Names								Module Name
			Bit 7	Bit 6	Bit 5	Bit 4	Bit 3	Bit 2	Bit 1	Bit 0	
H'EE000	P1DDR	8	P1 ₇ DDR	P1 ₆ DDR	P1 ₅ DDR	P1 ₄ DDR	P1 ₃ DDR	P1 ₂ DDR	P1 ₁ DDR	P1 ₀ DDR	Port 1
H'EE001	P2DDR	8	P2 ₇ DDR	P2 ₆ DDR	P2 ₅ DDR	P2 ₄ DDR	P2 ₃ DDR	P2 ₂ DDR	P2 ₁ DDR	P2 ₀ DDR	Port 2
H'EE002	P3DDR	8	P3 ₇ DDR	P3 ₆ DDR	P3 ₅ DDR	P3 ₄ DDR	P3 ₃ DDR	P3 ₂ DDR	P3 ₁ DDR	P3 ₀ DDR	Port 3
H'EE003	P4DDR	8	P4 ₇ DDR	P4 ₆ DDR	P4 ₅ DDR	P4 ₄ DDR	P4 ₃ DDR	P4 ₂ DDR	P4 ₁ DDR	P4 ₀ DDR	Port 4
H'EE004	P5DDR	8	—	—	—	—	P5 ₃ DDR	P5 ₂ DDR	P5 ₁ DDR	P5 ₀ DDR	Port 5
H'EE005	P6DDR	8	—	P6 ₆ DDR	P6 ₅ DDR	P6 ₄ DDR	P6 ₃ DDR	P6 ₂ DDR	P6 ₁ DDR	P6 ₀ DDR	Port 6
H'EE006	—	—	—	—	—	—	—	—	—	—	—
H'EE007	P8DDR	8	—	—	—	P8 ₄ DDR	P8 ₃ DDR	P8 ₂ DDR	P8 ₁ DDR	P8 ₀ DDR	Port 8
H'EE008	P9DDR	8	—	—	P9 ₅ DDR	P9 ₄ DDR	P9 ₃ DDR	P9 ₂ DDR	P9 ₁ DDR	P9 ₀ DDR	Port 9
H'EE009	PADDR	8	PA ₇ DDR	PA ₆ DDR	PA ₅ DDR	PA ₄ DDR	PA ₃ DDR	PA ₂ DDR	PA ₁ DDR	PA ₀ DDR	Port A
H'EE00A	PBDDR	8	PB ₇ DDR	PB ₆ DDR	PB ₅ DDR	PB ₄ DDR	PB ₃ DDR	PB ₂ DDR	PB ₁ DDR	PB ₀ DDR	Port B
H'EE00B	—	—	—	—	—	—	—	—	—	—	—
H'EE00C	—	—	—	—	—	—	—	—	—	—	—
H'EE00D	—	—	—	—	—	—	—	—	—	—	—
H'EE00E	—	—	—	—	—	—	—	—	—	—	—
H'EE00F	—	—	—	—	—	—	—	—	—	—	—
H'EE010	—	—	—	—	—	—	—	—	—	—	—
H'EE011	MDCR	8	—	—	—	—	—	MDS2	MDS1	MDS0	System control
H'EE012	SYSCR	8	SSBY	STS2	STS1	STS0	UE	NMIEG	SSOE	RAME	
H'EE013	BRCR	8	A23E	A22E	A21E	A20E	—	—	—	BRLE	Bus controller
H'EE014	ISCR	8	—	—	IRQ5SC	IRQ4SC	IRQ3SC	IRQ2SC	IRQ1SC	IRQ0SC	Interrupt controller
H'EE015	IER	8	—	—	IRQ5E	IRQ4E	IRQ3E	IRQ2E	IRQ1E	IRQ0E	
H'EE016	ISR	8	—	—	IRQ5F	IRQ4F	IRQ3F	IRQ2F	IRQ1F	IRQ0F	
H'EE017	—	—	—	—	—	—	—	—	—	—	—
H'EE018	IPRA	8	IPRA7	IPRA6	IPRA5	IPRA4	IPRA3	IPRA2	IPRA1	IPRA0	—
H'EE019	IPRB	8	IPRB7	IPRB6	IPRB5	—	IPRB3	IPRB2	IPRB1	—	—
H'EE01A	DASTCR	8	—	—	—	—	—	—	—	DASTE	D/A converter
H'EE01B	DIVCR	8	—	—	—	—	—	—	DIV1	DIV0	System control
H'EE01C	MSTCRH	8	PSTOP	—	—	—	—	MSTPH2	MSTPH1	MSTPH0	
H'EE01D	MSTCRL	8	MSTPL7	—	MSTPL5	MSTPL4	MSTPL3	MSTPL2	—	MSTPL0	—
H'EE01E	ADRCR	8	—	—	—	—	—	—	—	ADRCTL	Bus controller
H'EE01F	CSCR	8	CS7E	CS6E	CS5E	CS4E	—	—	—	—	—

Appendix B Internal I/O Registers

Address (Low)	Register Name	Data Bus Width	Bit Names								Module Name	
			Bit 7	Bit 6	Bit 5	Bit 4	Bit 3	Bit 2	Bit 1	Bit 0		
H'EE020	ABWCR	8	ABW7	ABW6	ABW5	ABW4	ABW3	ABW2	ABW1	ABW0	Bus controller	
H'EE021	ASTCR	8	AST7	AST6	AST5	AST4	AST3	AST2	AST1	AST0		
H'EE022	WCRH	8	W71	W70	W61	W60	W51	W50	W41	W40		
H'EE023	WCRL	8	W31	W30	W21	W20	W11	W10	W01	W00		
H'EE024	BCR	8	ICIS1	ICIS0	BROME	BRSTS1	BRSTS0	—	RDEA	WAITE		
H'EE025	—	—	—	—	—	—	—	—	—	—		
H'EE026	DRCRA	8	DRAS2	DRAS1	DRAS0	—	BE	RDM	SRFMD	RFSHE		DRAM Interface
H'EE027	DRCRB	8	MXC1	MXC0	CSEL	RCYCE	—	TPC	RCW	RLW		
H'EE028	RTMCSR	8	CMF	CMIE	CKS2	CKS1	CKS0	—	—	—		
H'EE029	RTCNT	8	—	—	—	—	—	—	—	—		
H'EE02A	RTCOR	8	—	—	—	—	—	—	—	—		
H'EE02B	Reserved area (access prohibited)											
H'EE02C	—											
H'EE02D	—											
H'EE02E	—											
H'EE02F	—											
H'EE030	FLMCR1	8	FWE	SWE	ESU	PSU	EV	PV	E	P	Flash memory	
H'EE031	FLMCR2	8	FLER	—	—	—	—	—	—	—		
H'EE032	EBR1	8	EB7	EB6	EB5	EB4	EB3	EB2	EB1	EB0		
H'EE033	EBR2	8	—	—	EB13	EB12	EB11	EB10	EB9	EB8		
H'EE034	Reserved area (access prohibited)											
H'EE035	—											
H'EE036	—											
H'EE037	—											
H'EE038	—											
H'EE039	—											
H'EE03A	—											
H'EE03B	—											
H'EE03C	P2PCR	8	P2 ₇ PCR	P2 ₆ PCR	P2 ₅ PCR	P2 ₄ PCR	P2 ₃ PCR	P2 ₂ PCR	P2 ₁ PCR	P2 ₀ PCR	Port 2	
H'EE03D	—	—	—	—	—	—	—	—	—	—	—	
H'EE03E	P4PCR	8	P4 ₇ PCR	P4 ₆ PCR	P4 ₅ PCR	P4 ₄ PCR	P4 ₃ PCR	P4 ₂ PCR	P4 ₁ PCR	P4 ₀ PCR	Port 4	
H'EE03F	P5PCR	8	—	—	—	—	P5 ₃ PCR	P5 ₂ PCR	P5 ₁ PCR	P5 ₀ PCR	Port 5	

Address (Low)	Register Name	Data Bus Width	Bit Names								Module Name
			Bit 7	Bit 6	Bit 5	Bit 4	Bit 3	Bit 2	Bit 1	Bit 0	
H'EE040	—	—	—	—	—	—	—	—	—	—	—
H'EE041	—	—	—	—	—	—	—	—	—	—	—
H'EE042	—	—	—	—	—	—	—	—	—	—	—
H'EE043	—	—	—	—	—	—	—	—	—	—	—
H'EE044	—	—	—	—	—	—	—	—	—	—	—
H'EE045	—	—	—	—	—	—	—	—	—	—	—
H'EE046	—	—	—	—	—	—	—	—	—	—	—
H'EE047	—	—	—	—	—	—	—	—	—	—	—
H'EE048	—	—	—	—	—	—	—	—	—	—	—
H'EE049	—	—	—	—	—	—	—	—	—	—	—
H'EE04A	—	—	—	—	—	—	—	—	—	—	—
H'EE04B	—	—	—	—	—	—	—	—	—	—	—
H'EE04C	—	—	—	—	—	—	—	—	—	—	—
H'EE04D	—	—	—	—	—	—	—	—	—	—	—
H'EE04E	—	—	—	—	—	—	—	—	—	—	—
H'EE04F	—	—	—	—	—	—	—	—	—	—	—
H'EE050	—	—	—	—	—	—	—	—	—	—	—
H'EE051	—	—	—	—	—	—	—	—	—	—	—
H'EE052	—	—	—	—	—	—	—	—	—	—	—
H'EE053	—	—	—	—	—	—	—	—	—	—	—
H'EE054	—	—	—	—	—	—	—	—	—	—	—
H'EE055	—	—	—	—	—	—	—	—	—	—	—
H'EE056	—	—	—	—	—	—	—	—	—	—	—
H'EE057	—	—	—	—	—	—	—	—	—	—	—
H'EE058	—	—	—	—	—	—	—	—	—	—	—
H'EE059	—	—	—	—	—	—	—	—	—	—	—
H'EE05A	—	—	—	—	—	—	—	—	—	—	—
H'EE05B	—	—	—	—	—	—	—	—	—	—	—
H'EE05C	—	—	—	—	—	—	—	—	—	—	—
H'EE05D	—	—	—	—	—	—	—	—	—	—	—
H'EE05E	—	—	—	—	—	—	—	—	—	—	—
H'EE05F	—	—	—	—	—	—	—	—	—	—	—

Appendix B Internal I/O Registers

Address (Low)	Register Name	Data Bus Width	Bit Names								Module Name	
			Bit 7	Bit 6	Bit 5	Bit 4	Bit 3	Bit 2	Bit 1	Bit 0		
H'EE060	—	—	—	—	—	—	—	—	—	—	—	
H'EE061	—	—	—	—	—	—	—	—	—	—	—	
H'EE062	—	—	—	—	—	—	—	—	—	—	—	
H'EE063	—	—	—	—	—	—	—	—	—	—	—	
H'EE064	—	—	—	—	—	—	—	—	—	—	—	
H'EE065	—	—	—	—	—	—	—	—	—	—	—	
H'EE066	—	—	—	—	—	—	—	—	—	—	—	
H'EE067	—	—	—	—	—	—	—	—	—	—	—	
H'EE068	—	—	—	—	—	—	—	—	—	—	—	
H'EE069	—	—	—	—	—	—	—	—	—	—	—	
H'EE06A	—	—	—	—	—	—	—	—	—	—	—	
H'EE06B	—	—	—	—	—	—	—	—	—	—	—	
H'EE06C	—	—	—	—	—	—	—	—	—	—	—	
H'EE06D	—	—	—	—	—	—	—	—	—	—	—	
H'EE06E	—	—	—	—	—	—	—	—	—	—	—	
H'EE06F	—	—	—	—	—	—	—	—	—	—	—	
H'EE070	—	—	—	—	—	—	—	—	—	—	—	
H'EE071	—	—	—	—	—	—	—	—	—	—	—	
H'EE072	—	—	—	—	—	—	—	—	—	—	—	
H'EE073	—	—	—	—	—	—	—	—	—	—	—	
H'EE074	Reserved area (access prohibited)											
H'EE075												
H'EE076												
H'EE077	RAMCR *1	8	—	—	—	—	RAMS	RAM2	RAM1	RAM0		Flash memory*1
H'EE078	Reserved area (access prohibited)											
H'EE079												
H'EE07A												
H'EE07B												
H'EE07C												
H'EE07D												
H'EE07E												
H'EE07F												

Address (Low)	Register Name	Data Bus Width	Bit Names								Module Name
			Bit 7	Bit 6	Bit 5	Bit 4	Bit 3	Bit 2	Bit 1	Bit 0	
H'EE080	Reserved area (access prohibited)									Flash memory* ¹	
H'EE081											
H'FFF20	MAR0AR	8									DMAC channel 0A
H'FFF21	MAR0AE	8									
H'FFF22	MAR0AH	8									
H'FFF23	MAR0AL	8									
H'FFF24	ETCR0AH	8									
H'FFF25	ETCR0AL	8									
H'FFF26	IOAR0A	8									
H'FFF27	DTCR0A	8	DTE	DTSZ	DTID	RPE	DTIE	DTS2	DTS1	DTS0	Short address mode
			DTE	DTSZ	SAID	SAIDE	DTIE	DTS2A	DTS1A	DTS0A	Full address mode
H'FFF28	MAR0BR	8									DMAC channel 0B
H'FFF29	MAR0BE	8									
H'FFF2A	MAR0BH	8									
H'FFF2B	MAR0BL	8									
H'FFF2C	ETCR0BH	8									
H'FFF2D	ETCR0BL	8									
H'FFF2E	IOAR0B	8									
H'FFF2F	DTCR0B	8	DTE	DTSZ	DTID	RPE	DTIE	DTS2	DTS1	DTS0	Short address mode
			DTME	—	DAID	DAIDE	TMS	DTS2B	DTS1B	DTS0B	Full address mode
H'FFF30	MAR1AR	8									DMAC channel 1A
H'FFF31	MAR1AE	8									
H'FFF32	MAR1AH	8									
H'FFF33	MAR1AL	8									
H'FFF34	ETCR1AH	8									
H'FFF35	ETCR1AL	8									
H'FFF36	IOAR1A	8									
H'FFF37	DTCR1A	8	DTE	DTSZ	DTID	RPE	DTIE	DTS2	DTS1	DTS0	Short address mode
			DTE	DTSZ	SAID	SAIDE	DTIE	DTS2A	DTS1A	DTS0A	Full address mode
H'FFF38	MAR1BR	8									DMAC channel 1B
H'FFF39	MAR1BE	8									
H'FFF3A	MAR1BH	8									
H'FFF3B	MAR1BL	8									
H'FFF3C	ETCR1BH	8									
H'FFF3D	ETCR1BL	8									
H'FFF3E	IOAR1B	8									
H'FFF3F	DTCR1B	8	DTE	DTSZ	DTID	RPE	DTIE	DTS2	DTS1	DTS0	Short address mode
			DTME	—	DAID	DAIDE	TMS	DTS2B	DTS1B	DTS0B	Full address mode

Address (Low)	Register Name	Data Bus Width	Bit Names								Module Name
			Bit 7	Bit 6	Bit 5	Bit 4	Bit 3	Bit 2	Bit 1	Bit 0	
H'FFF40	—	—	—	—	—	—	—	—	—	—	—
H'FFF41	—	—	—	—	—	—	—	—	—	—	—
H'FFF42	—	—	—	—	—	—	—	—	—	—	—
H'FFF43	—	—	—	—	—	—	—	—	—	—	—
H'FFF44	—	—	—	—	—	—	—	—	—	—	—
H'FFF45	—	—	—	—	—	—	—	—	—	—	—
H'FFF46	—	—	—	—	—	—	—	—	—	—	—
H'FFF47	—	—	—	—	—	—	—	—	—	—	—
H'FFF48	—	—	—	—	—	—	—	—	—	—	—
H'FFF49	—	—	—	—	—	—	—	—	—	—	—
H'FFF4A	—	—	—	—	—	—	—	—	—	—	—
H'FFF4B	—	—	—	—	—	—	—	—	—	—	—
H'FFF4C	—	—	—	—	—	—	—	—	—	—	—
H'FFF4D	—	—	—	—	—	—	—	—	—	—	—
H'FFF4E	—	—	—	—	—	—	—	—	—	—	—
H'FFF4F	—	—	—	—	—	—	—	—	—	—	—
H'FFF50	—	—	—	—	—	—	—	—	—	—	—
H'FFF51	—	—	—	—	—	—	—	—	—	—	—
H'FFF52	—	—	—	—	—	—	—	—	—	—	—
H'FFF53	—	—	—	—	—	—	—	—	—	—	—
H'FFF54	—	—	—	—	—	—	—	—	—	—	—
H'FFF55	—	—	—	—	—	—	—	—	—	—	—
H'FFF56	—	—	—	—	—	—	—	—	—	—	—
H'FFF57	—	—	—	—	—	—	—	—	—	—	—
H'FFF58	—	—	—	—	—	—	—	—	—	—	—
H'FFF59	—	—	—	—	—	—	—	—	—	—	—
H'FFF5A	—	—	—	—	—	—	—	—	—	—	—
H'FFF5B	—	—	—	—	—	—	—	—	—	—	—
H'FFF5C	—	—	—	—	—	—	—	—	—	—	—
H'FFF5D	—	—	—	—	—	—	—	—	—	—	—
H'FFF5E	—	—	—	—	—	—	—	—	—	—	—
H'FFF5F	—	—	—	—	—	—	—	—	—	—	—

Address (Low)	Register Name	Data Bus Width	Bit Names									Module Name
			Bit 7	Bit 6	Bit 5	Bit 4	Bit 3	Bit 2	Bit 1	Bit 0		
H'FFF60	TSTR	8	—	—	—	—	—	—	STR2	STR1	STR0	16-bit timer, (all channels)
H'FFF61	TSNC	8	—	—	—	—	—	—	SYNC2	SYNC1	SYNC0	
H'FFF62	TMDR	8	—	MDF	FDIR	—	—	—	PWM2	PWM1	PWM0	
H'FFF63	TOLR	8	—	—	TOB2	TOA2	TOB1	TOA1	TOB0	TOA0	—	
H'FFF64	TISRA	8	—	IMIEA2	IMIEA1	IMIEA0	—	—	IMFA2	IMFA1	IMFA0	
H'FFF65	TISRB	8	—	IMIEB2	IMIEB1	IMIEB0	—	—	IMFB2	IMFB1	IMFB0	
H'FFF66	TISRC	8	—	OVIE2	OVIE1	OVIE0	—	—	OVF2	OVF1	OVF0	
H'FFF67												
H'FFF68	TCR0	8	—	CCLR1	CCLR0	CKEG1	CKEG0	TPSC2	TPSC1	TPSC0	16-bit timer channel 0	
H'FFF69	TIOR0	8	—	IOB2	IOB1	IOB0	—	IOA2	IOA1	IOA0		
H'FFF6A	TCNT0H	16										
H'FFF6B	TCNT0L											
H'FFF6C	GRA0H	16										
H'FFF6D	GRA0L											
H'FFF6E	GRB0H	16										
H'FFF6F	GRB0L											
H'FFF70	TCR1	8	—	CCLR1	CCLR0	CKEG1	CKEG0	TPSC2	TPSC1	TPSC0		16-bit timer channel 1
H'FFF71	TIOR1	8	—	IOB2	IOB1	IOB0	—	IOA2	IOA1	IOA0		
H'FFF72	TCNT1H	16										
H'FFF73	TCNT1L											
H'FFF74	GRA1H	16										
H'FFF75	GRA1L											
H'FFF76	GRB1H	16										
H'FFF77	GRB1L											
H'FFF78	TCR2	8	—	CCLR1	CCLR0	CKEG1	CKEG0	TPSC2	TPSC1	TPSC0	16-bit timer channel 2	
H'FFF79	TIOR2	8	—	IOB2	IOB1	IOB0	—	IOA2	IOA1	IOA0		
H'FFF7A	TCNT2H	16										
H'FFF7B	TCNT2L											
H'FFF7C	GRA2H	16										
H'FFF7D	GRA2L											
H'FFF7E	GRB2H	16										
H'FFF7F	GRB2L											

Address (Low)	Register Name	Data Bus Width	Bit Names								Module Name
			Bit 7	Bit 6	Bit 5	Bit 4	Bit 3	Bit 2	Bit 1	Bit 0	
H'FFF80	TCR0	8	CMIEB	CMIEA	OVIE	CCLR1	CCLR0	CKS2	CKS1	CKS0	8-bit timer channels 0 and 1
H'FFF81	TCR1	8	CMIEB	CMIEA	OVIE	CCLR1	CCLR0	CKS2	CKS1	CKS0	
H'FFF82	TCSR0	8	CMFB	CMFA	OVF	ADTE	OIS3	OIS2	OS1	OS0	
H'FFF83	TCSR1	8	CMFB	CMFA	OVF	ICE	OIS3	OIS2	OS1	OS0	
H'FFF84	TCORA0	8									
H'FFF85	TCORA1	8									
H'FFF86	TCORB0	8									
H'FFF87	TCORB1	8									
H'FFF88	TCNT0	8									
H'FFF89	TCNT1	8									
H'FFF8A	—		—	—	—	—	—	—	—	—	
H'FFF8B	—		—	—	—	—	—	—	—	—	
H'FFF8C	TCSR* ²	8	OVF	WT/ $\bar{I}\bar{T}$	TME	—	—	CKS2	CKS1	CKS0	WDT
H'FFF8D	TCNT* ²	8									
H'FFF8E	—		—	—	—	—	—	—	—	—	
H'FFF8F	RSTCSR * ²	8	WRST	RSTOE	—	—	—	—	—	—	
H'FFF90	TCR2	8	CMIEB	CMIEA	OVIE	CCLR1	CCLR0	CKS2	CKS1	CKS0	8-bit timer channels 2 and 3
H'FFF91	TCR3	8	CMIEB	CMIEA	OVIE	CCLR1	CCLR0	CKS2	CKS1	CKS0	
H'FFF92	TCSR2	8	CMFB	CMFA	OVF	—	OIS3	OIS2	OS1	OS0	
H'FFF93	TCSR3	8	CMFB	CMFA	OVF	ICE	OIS3	OIS2	OS1	OS0	
H'FFF94	TCORA2	8									
H'FFF95	TCORA3	8									
H'FFF96	TCORB2	8									
H'FFF97	TCORB3	8									
H'FFF98	TCNT2	8									
H'FFF99	TCNT3	8									
H'FFF9A	—		—	—	—	—	—	—	—	—	
H'FFF9B	—		—	—	—	—	—	—	—	—	
H'FFF9C	DADR0	8									D/A converter
H'FFF9D	DADR1	8									
H'FFF9E	DACR	8	DAOE1	DAOE0	DAE	—	—	—	—	—	
H'FFF9F	—	8	—	—	—	—	—	—	—	—	

Address (Low)	Register Name	Data Bus Width	Bit Names								Module Name
			Bit 7	Bit 6	Bit 5	Bit 4	Bit 3	Bit 2	Bit 1	Bit 0	
H'FFFA0	TPMR	8	—	—	—	—	G3NOV	G2NOV	G1NOV	G0NOV	TPC
H'FFFA1	TPCR	8	G3CMS1	G3CMS0	G2CMS1	G2CMS0	G1CMS1	G1CMS0	G0CMS1	G0CMS0	
H'FFFA2	NDERB	8	NDER15	NDER14	NDER13	NDER12	NDER11	NDER10	NDER9	NDER8	
H'FFFA3	NDERA	8	NDER7	NDER6	NDER5	NDER4	NDER3	NDER2	NDER1	NDER0	
H'FFFA4	NDRB* ³	8	NDER15	NDER14	NDER13	NDER12	NDER11	NDER10	NDER9	NDER8	
			NDER15	NDER14	NDER13	NDER12	—	—	—	—	
H'FFFA5	NDRA* ³	8	NDER7	NDER6	NDER5	NDER4	NDER3	NDER2	NDER1	NDER0	
			NDER7	NDER6	NDER5	NDER4	—	—	—	—	
H'FFFA6	NDRB* ³	8	—	—	—	—	—	—	—	—	
			—	—	—	—	NDER11	NDER10	NDER9	NDER8	
H'FFFA7	NDRA* ³	8	—	—	—	—	—	—	—	—	
			—	—	—	—	NDER3	NDER2	NDER1	NDER0	
H'FFFA8											
H'FFFA9											
H'FFFAA											
H'FFFAB											
H'FFFAC											
H'FFFAD											
H'FFFAE											
H'FFFAF											
H'FFFB0	SMR	8	C/ \bar{A}	CHR	PE	O/ \bar{E}	STOP	MP	CKS1	CKS0	SCI channel 0
H'FFFB1	BRR	8									
H'FFFB2	SCR	8	TIE	RIE	TE	RE	MPIE	TEIE	CKE1	CKE0	
H'FFFB3	TDR	8									
H'FFFB4	SSR	8	TDRE	RDRF	ORER	FER/ERS	PER	TEND	MPB	MPBT	
H'FFFB5	RDR	8									
H'FFFB6	SCMR	8	—	—	—	—	SDIR	SINV	—	SMIF	
H'FFFB7	Reserved area (access prohibited)										
H'FFFB8	SMR	8	C/ \bar{A}	CHR	PE	O/ \bar{E}	STOP	MP	CKS1	CKS0	SCI channel 1
H'FFFB9	BRR	8									
H'FFBBA	SCR	8	TIE	RIE	TE	RE	MPIE	TEIE	CKE1	CKE0	
H'FFBBB	TDR	8									
H'FFBBC	SSR	8	TDRE	RDRF	ORER	FER/ERS	PER	TEND	MPB	MPBT	
H'FFBBD	RDR	8									
H'FFBBE	SCMR	8	—	—	—	—	SDIR	SINV	—	SMIF	
H'FFBBF	Reserved area (access prohibited)										

Address (Low)	Register Name	Data Bus Width	Bit Names								Module Name
			Bit 7	Bit 6	Bit 5	Bit 4	Bit 3	Bit 2	Bit 1	Bit 0	
H'FFFC0	SMR	8	C/ \bar{A}	CHR	PE	O/ \bar{E}	STOP	MP	CKS1	CKS0	SCI channel 2
H'FFFC1	BRR	8									
H'FFFC2	SCR	8	TIE	RIE	TE	RE	MPIE	TEIE	CKE1	CKE0	
H'FFFC3	TDR	8									
H'FFFC4	SSR	8	TDRE	RDRF	ORER	FER/ERS	PER	TEND	MPB	MPBT	
H'FFFC5	RDR	8									
H'FFFC6	SCMR	8	—	—	—	—	SDIR	SINV	—	SMIF	
H'FFFC7	Reserved area (access prohibited)										
H'FFFC8	—	—	—	—	—	—	—	—	—	—	
H'FFFC9	—	—	—	—	—	—	—	—	—	—	
H'FFFC A	—	—	—	—	—	—	—	—	—	—	
H'FFFC B	—	—	—	—	—	—	—	—	—	—	
H'FFFC C	—	—	—	—	—	—	—	—	—	—	
H'FFFC D	—	—	—	—	—	—	—	—	—	—	
H'FFFC E	—	—	—	—	—	—	—	—	—	—	
H'FFFC F	—	—	—	—	—	—	—	—	—	—	
H'FFFD0	P1DR	8	P1 ₇	P1 ₆	P1 ₅	P1 ₄	P1 ₃	P1 ₂	P1 ₁	P1 ₀	Port1
H'FFFD1	P2DR	8	P2 ₇	P2 ₆	P2 ₅	P2 ₄	P2 ₃	P2 ₂	P2 ₁	P2 ₀	Port2
H'FFFD2	P3DR	8	P3 ₇	P3 ₆	P3 ₅	P3 ₄	P3 ₃	P3 ₂	P3 ₁	P3 ₀	Port3
H'FFFD3	P4DR	8	P4 ₇	P4 ₆	P4 ₅	P4 ₄	P4 ₃	P4 ₂	P4 ₁	P4 ₀	Port4
H'FFFD4	P5DR	8	—	—	—	—	P5 ₃	P5 ₂	P5 ₁	P5 ₀	Port5
H'FFFD5	P6DR	8	P6 ₇	P6 ₆	P6 ₅	P6 ₄	P6 ₃	P6 ₂	P6 ₁	P6 ₀	Port6
H'FFFD6	P7DR	8	P7 ₇	P7 ₆	P7 ₅	P7 ₄	P7 ₃	P7 ₂	P7 ₁	P7 ₀	Port7
H'FFFD7	P8DR	8	—	—	—	P8 ₄	P8 ₃	P8 ₂	P8 ₁	P8 ₀	Port8
H'FFFD8	P9DR	8	—	—	P9 ₅	P9 ₄	P9 ₃	P9 ₂	P9 ₁	P9 ₀	Port9
H'FFFD9	PADR	8	PA ₇	PA ₆	PA ₅	PA ₄	PA ₃	PA ₂	PA ₁	PA ₀	PortA
H'FFFDA	PBDR	8	PB ₇	PB ₆	PB ₅	PB ₄	PB ₃	PB ₂	PB ₁	PB ₀	PortB
H'FFFDB	—	—	—	—	—	—	—	—	—	—	
H'FFFDC	—	—	—	—	—	—	—	—	—	—	
H'FFFDD	—	—	—	—	—	—	—	—	—	—	
H'FFFDE	—	—	—	—	—	—	—	—	—	—	
H'FFDFD	—	—	—	—	—	—	—	—	—	—	

Address (Low)	Register Name	Data Bus Width	Bit Names								Module Name
			Bit 7	Bit 6	Bit 5	Bit 4	Bit 3	Bit 2	Bit 1	Bit 0	
H'FFFE0	ADDRAH	8	AD9	AD8	AD7	AD6	AD5	AD4	AD3	AD2	A/D converter
H'FFFE1	ADDRAL	8	AD1	AD0	—	—	—	—	—	—	
H'FFFE2	ADDRBH	8	AD9	AD8	AD7	AD6	AD5	AD4	AD3	AD2	
H'FFFE3	ADDRBL	8	AD1	AD0	—	—	—	—	—	—	
H'FFFE4	ADDRCH	8	AD9	AD8	AD7	AD6	AD5	AD4	AD3	AD2	
H'FFFE5	ADDRCL	8	AD1	AD0	—	—	—	—	—	—	
H'FFFE6	ADDRDH	8	AD9	AD8	AD7	AD6	AD5	AD4	AD3	AD2	
H'FFFE7	ADDRDL	8	AD1	AD0	—	—	—	—	—	—	
H'FFFE8	ADCSR	8	ADF	ADIE	ADST	SCAN	CKS	CH2	CH1	CH0	
H'FFFE9	ADCR	8	TRGE	—	—	—	—	—	—	—	

- Notes:
1. The RAMCR and FLMCR registers are used only in the flash memory and flash memory R versions, and are not provided in the mask ROM versions.
 2. For write access to TCSR, TCNT, and RSTCSR, see section 12.2.4, Notes on Register Access.
 3. The address depends on the output trigger setting.

Legend

WDT: Watchdog timer

TPC: Programmable timing pattern controller

SCI: Serial communication interface

B.2 Addresses (EMC = 0)

Address (Low)	Register Name	Data Bus Width	Bit Names								Module Name
			Bit 7	Bit 6	Bit 5	Bit 4	Bit 3	Bit 2	Bit 1	Bit 0	
H'EE000	P1DDR	8	P1 ₇ DDR	P1 ₆ DDR	P1 ₅ DDR	P1 ₄ DDR	P1 ₃ DDR	P1 ₂ DDR	P1 ₁ DDR	P1 ₀ DDR	Port 1
H'EE001	P2DDR	8	P2 ₇ DDR	P2 ₆ DDR	P2 ₅ DDR	P2 ₄ DDR	P2 ₃ DDR	P2 ₂ DDR	P2 ₁ DDR	P2 ₀ DDR	Port 2
H'EE002	P3DDR	8	P3 ₇ DDR	P3 ₆ DDR	P3 ₅ DDR	P3 ₄ DDR	P3 ₃ DDR	P3 ₂ DDR	P3 ₁ DDR	P3 ₀ DDR	Port 3
H'EE003	P4DDR	8	P4 ₇ DDR	P4 ₆ DDR	P4 ₅ DDR	P4 ₄ DDR	P4 ₃ DDR	P4 ₂ DDR	P4 ₁ DDR	P4 ₀ DDR	Port 4
H'EE004	P5DDR	8	—	—	—	—	P5 ₃ DDR	P5 ₂ DDR	P5 ₁ DDR	P5 ₀ DDR	Port 5
H'EE005	P6DDR	8	—	P6 ₆ DDR	P6 ₅ DDR	P6 ₄ DDR	P6 ₃ DDR	P6 ₂ DDR	P6 ₁ DDR	P6 ₀ DDR	Port 6
H'EE006	—	—	—	—	—	—	—	—	—	—	—
H'EE007	P8DDR	8	—	—	—	P8 ₄ DDR	P8 ₃ DDR	P8 ₂ DDR	P8 ₁ DDR	P8 ₀ DDR	Port 8
H'EE008	P9DDR	8	—	—	P9 ₅ DDR	P9 ₄ DDR	P9 ₃ DDR	P9 ₂ DDR	P9 ₁ DDR	P9 ₀ DDR	Port 9
H'EE009	PADDR	8	PA ₇ DDR	PA ₆ DDR	PA ₅ DDR	PA ₄ DDR	PA ₃ DDR	PA ₂ DDR	PA ₁ DDR	PA ₀ DDR	Port A
H'EE00A	PBDDR	8	PB ₇ DDR	PB ₆ DDR	PB ₅ DDR	PB ₄ DDR	PB ₃ DDR	PB ₂ DDR	PB ₁ DDR	PB ₀ DDR	Port B
H'EE00B	—	—	—	—	—	—	—	—	—	—	—
H'EE00C	—	—	—	—	—	—	—	—	—	—	—
H'EE00D	—	—	—	—	—	—	—	—	—	—	—
H'EE00E	—	—	—	—	—	—	—	—	—	—	—
H'EE00F	—	—	—	—	—	—	—	—	—	—	—
H'EE010	—	—	—	—	—	—	—	—	—	—	—
H'EE011	MDCR	8	—	—	—	—	—	MDS2	MDS1	MDS0	System control
H'EE012	SYSCR	8	SSBY	STS2	STS1	STS0	UE	NMIEG	SSOE	RAME	System control
H'EE013	BRCR	8	A23E	A22E	A21E	A20E	—	—	—	BRLE	Bus controller
H'EE014	ISCR	8	—	—	IRQ5SC	IRQ4SC	IRQ3SC	IRQ2SC	IRQ1SC	IRQ0SC	Interrupt controller
H'EE015	IER	8	—	—	IRQ5E	IRQ4E	IRQ3E	IRQ2E	IRQ1E	IRQ0E	Interrupt controller
H'EE016	ISR	8	—	—	IRQ5F	IRQ4F	IRQ3F	IRQ2F	IRQ1F	IRQ0F	Interrupt controller
H'EE017	—	8	—	—	—	—	—	—	—	—	—
H'EE018	IPRA	8	IPRA7	IPRA6	IPRA5	IPRA4	IPRA3	IPRA2	IPRA1	IPRA0	—
H'EE019	IPRB	8	IPRB7	IPRB6	IPRB5	—	IPRB3	IPRB2	IPRB1	—	—
H'EE01A	DASTCR	8	—	—	—	—	—	—	—	DASTE	D/A converter
H'EE01B	DIVCR	8	—	—	—	—	—	—	DIV1	DIV0	System control
H'EE01C	MSTCRH	8	PSTOP	—	—	—	—	MSTPH2	MSTPH1	MSTPH0	System control
H'EE01D	MSTCRL	8	MSTPL7	—	MSTPL5	MSTPL4	MSTPL3	MSTPL2	—	MSTPL0	—
H'EE01E	ADRCR	8	—	—	—	—	—	—	—	ADRCTL	Bus controller
H'EE01F	CSCR	8	CS7E	CS6E	CS5E	CS4E	—	—	—	—	—

Address (Low)	Register Name	Data Bus Width	Bit Names								Module Name
			Bit 7	Bit 6	Bit 5	Bit 4	Bit 3	Bit 2	Bit 1	Bit 0	
H'EE020	ABWCR	8	ABW7	ABW6	ABW5	ABW4	ABW3	ABW2	ABW1	ABW0	Bus controller
H'EE021	ASTCR	8	AST7	AST6	AST5	AST4	AST3	AST2	AST1	AST0	
H'EE022	WCRH	8	W71	W70	W61	W60	W51	W50	W41	W40	
H'EE023	WCRL	8	W31	W30	W21	W20	W11	W10	W01	W00	
H'EE024	BCR	8	ICIS1	ICIS0	BROME	BRSTS1	BRSTS0	EMC	RDEA	WAITE	
H'EE025	(FLWCR)	8	—	—	—	—	—	—	—	—	
H'EE026	DRCRA	8	DRAS2	DRAS1	DRAS0	—	BE	RDM	SRFMD	RFSHE	DRAM interface
H'EE027	DRCRB	8	MXC1	MXC0	CSEL	RCYCE	—	TPC	RCW	RLW	
H'EE028	RTMCSR	8	CMF	CMIE	CKS2	CKS1	CKS0	—	—	—	
H'EE029	RTCNT	8									
H'EE02A	RTCOR	8									
H'EE02B	—	8									Bus controller
H'EE02C	DCR0	8									
H'EE02D	DCR1	8									
H'EE02E	DCR2	8									
H'EE02F	DCR3	8									
H'EE030	FLMCR1	8	FWE	SWE	ESU	PSU	EV	PV	E	P	Flash memory
H'EE031	FLMCR2	8	FLER								
H'EE032	EBR1	8	EB7	EB6	EB5	EB4	EB3	EB2	EB1	EB0	
H'EE033	EBR2	8	—	—	EB13	EB12	EB11	EB10	EB9	EB8	
H'EE034	Reserved area (access prohibited)										
H'EE035											
H'EE036											
H'EE037											
H'EE03C	P2PCR	8	P2 ₇ PCR	P2 ₆ PCR	P2 ₅ PCR	P2 ₄ PCR	P2 ₃ PCR	P2 ₂ PCR	P2 ₇ PCR	P2 ₀ PCR	Port 2
H'EE03D	—	8	—	—	—	—	—	—	—	—	
H'EE03E	P4PCR	8	P4 ₇ PCR	P4 ₆ PCR	P4 ₅ PCR	P4 ₄ PCR	P4 ₃ PCR	P4 ₂ PCR	P4 ₁ PCR	P4 ₀ PCR	Port 4
H'EE03F	P5PCR	8	—	—	—	—	P5 ₃ PCR	P5 ₂ PCR	P5 ₁ PCR	P5 ₀ PCR	Port 5

Address (Low)	Register Name	Data Bus Width	Bit Names								Module Name
			Bit 7	Bit 6	Bit 5	Bit 4	Bit 3	Bit 2	Bit 1	Bit 0	
H'EE040	—	—	—	—	—	—	—	—	—	—	—
H'EE041	—	—	—	—	—	—	—	—	—	—	—
H'EE042	—	—	—	—	—	—	—	—	—	—	—
H'EE043	—	—	—	—	—	—	—	—	—	—	—
H'EE044	—	—	—	—	—	—	—	—	—	—	—
H'EE045	—	—	—	—	—	—	—	—	—	—	—
H'EE046	—	—	—	—	—	—	—	—	—	—	—
H'EE047	—	—	—	—	—	—	—	—	—	—	—
H'EE048	—	—	—	—	—	—	—	—	—	—	—
H'EE049	—	—	—	—	—	—	—	—	—	—	—
H'EE04A	—	—	—	—	—	—	—	—	—	—	—
H'EE04B	—	—	—	—	—	—	—	—	—	—	—
H'EE04C	—	—	—	—	—	—	—	—	—	—	—
H'EE04D	—	—	—	—	—	—	—	—	—	—	—
H'EE04E	—	—	—	—	—	—	—	—	—	—	—
H'EE04F	—	—	—	—	—	—	—	—	—	—	—
H'EE050	—	—	—	—	—	—	—	—	—	—	—
H'EE051	—	—	—	—	—	—	—	—	—	—	—
H'EE052	—	—	—	—	—	—	—	—	—	—	—
H'EE053	—	—	—	—	—	—	—	—	—	—	—
H'EE054	—	—	—	—	—	—	—	—	—	—	—
H'EE055	—	—	—	—	—	—	—	—	—	—	—
H'EE056	—	—	—	—	—	—	—	—	—	—	—
H'EE057	—	—	—	—	—	—	—	—	—	—	—
H'EE058	—	—	—	—	—	—	—	—	—	—	—
H'EE059	—	—	—	—	—	—	—	—	—	—	—
H'EE05A	—	—	—	—	—	—	—	—	—	—	—
H'EE05B	—	—	—	—	—	—	—	—	—	—	—
H'EE05C	—	—	—	—	—	—	—	—	—	—	—
H'EE05D	—	—	—	—	—	—	—	—	—	—	—
H'EE05E	—	—	—	—	—	—	—	—	—	—	—
H'EE05F	—	—	—	—	—	—	—	—	—	—	—

Address (Low)	Register Name	Data Bus Width	Bit Names								Module Name	
			Bit 7	Bit 6	Bit 5	Bit 4	Bit 3	Bit 2	Bit 1	Bit 0		
H'EE060	—	—	—	—	—	—	—	—	—	—	—	
H'EE061	—	—	—	—	—	—	—	—	—	—	—	
H'EE062	—	—	—	—	—	—	—	—	—	—	—	
H'EE063	—	—	—	—	—	—	—	—	—	—	—	
H'EE064	—	—	—	—	—	—	—	—	—	—	—	
H'EE065	—	—	—	—	—	—	—	—	—	—	—	
H'EE066	—	—	—	—	—	—	—	—	—	—	—	
H'EE067	—	—	—	—	—	—	—	—	—	—	—	
H'EE068	—	—	—	—	—	—	—	—	—	—	—	
H'EE069	—	—	—	—	—	—	—	—	—	—	—	
H'EE06A	—	—	—	—	—	—	—	—	—	—	—	
H'EE06B	—	—	—	—	—	—	—	—	—	—	—	
H'EE06C	—	—	—	—	—	—	—	—	—	—	—	
H'EE06D	—	—	—	—	—	—	—	—	—	—	—	
H'EE06E	—	—	—	—	—	—	—	—	—	—	—	
H'EE06F	—	—	—	—	—	—	—	—	—	—	—	
H'EE070	Reserved area (access prohibited)											
H'EE071												
H'EE072												
H'EE073												
H'EE074												
H'EE075												
H'EE076												
H'EE077	RAMCR *1	8	—	—	—	—	—	RAMS	RAM2	RAM1	RAM0	Flash memory*1
H'EE078	Reserved area (access prohibited)											
H'EE079												
H'EE07A												
H'EE07B												
H'EE07C												
H'EE07D												
H'EE07E												
H'EE07F												

Address (Low)	Register Name	Data Bus Width	Bit Names								Module Name
			Bit 7	Bit 6	Bit 5	Bit 4	Bit 3	Bit 2	Bit 1	Bit 0	
H'EE090	TCSR* ²	8	OVF	WT/ \overline{IT}	TME	—	—	CKS2	CKS1	CKS0	WDT
H'EE091	TCNT* ²	8									
H'EE092	—		—	—	—	—	—	—	—	—	
H'EE093	RSTCSR* ²	8	WRST	—	—	—	—	—	—	—	
H'EE094	Reserved area (access prohibited)										
H'EE095											
H'EE096											
H'EE097											
H'EE098											
H'EE099											
H'EE09A											
H'EE09B											
H'EE09C											
H'EE09D											
H'EE09E											
H'EE09F											
H'EE0A0											
H'EE0A1											
H'EE0A2											
H'EE0A3											
H'EE0A4											
H'EE0A5											
H'EE0A6											
H'EE0A7											
H'EE0A8											
H'EE0A9											
H'EE0AA											
H'EE0AB											
H'EE0AC											
H'EE0AD											
H'EE0AE											
H'EE0AF											

Address (Low)	Register Name	Data Bus Width	Bit Names								Module Name
			Bit 7	Bit 6	Bit 5	Bit 4	Bit 3	Bit 2	Bit 1	Bit 0	
H'EE0B0	Reserved area (access prohibited)										
H'EE0B1											
H'EE0B2											
H'EE0B3											
H'EE0B4											
H'EE0B5											
H'EE0B6											
H'EE0B7											
H'EE0B8											
H'EE0B9											
H'EE0BA											
H'EE0BB											
H'EE0BC											
H'EE0BD											
H'EE0BE											
H'EE0BF											
H'EE0C0											
H'EE0C1											
H'EE0C2											
H'EE0C3											
H'EE0C4											
H'EE0C5											
H'EE0C6											
H'EE0C7											
H'EE0C8											
H'EE0C9											
H'EE0CA											
H'EE0CB											
H'EE0CC											
H'EE0CD											
H'EE0CE											
H'EE0CF											

Address (Low)	Register Name	Data Bus Width	Bit Names								Module Name	
			Bit 7	Bit 6	Bit 5	Bit 4	Bit 3	Bit 2	Bit 1	Bit 0		
H'EE0D0	Reserved area (access prohibited)											
H'EE0D1												
H'EE0D2												
H'EE0D3												
H'EE0D4												
H'EE0D5												
H'EE0D6												
H'EE0D7												
H'EE0D8												
H'EE0D9												
H'EE0DA												
H'EE0DB												
H'EE0DC												
H'EE0DD												
H'EE0DE												
H'EE0DF												
H'EE0E0												
H'EE0E1												
H'EE0E2												
H'EE0E3												
H'EE0E4												
H'EE0E5												
H'EE0E6												
H'EE0E7												
H'EE0E8												
H'EE0E9												
H'EE0EA												
H'EE0EB												
H'EE0EC												
H'EE0ED												
H'EE0EE												
H'EE0EF												

Address (Low)	Register Name	Data Bus Width	Bit Names								Module Name
			Bit 7	Bit 6	Bit 5	Bit 4	Bit 3	Bit 2	Bit 1	Bit 0	
H'EE0F0	Reserved area (access prohibited)										
H'EE0F1											
H'EE0F2											
H'EE0F3											
H'EE0F4											
H'EE0F5											
H'EE0F6											
H'EE0F7											
H'EE0F8											
H'EE0F9											
H'EE0FA											
H'EE0FB											
H'EE0FC											
H'EE0FD											
H'EE0FE											
H'EE0FF											
H'FFE00	—		—	—	—	—	—	—	—	—	
H'FFE01	—		—	—	—	—	—	—	—	—	
H'FFE02	—		—	—	—	—	—	—	—	—	
H'FFE03	—		—	—	—	—	—	—	—	—	
H'FFE04	—		—	—	—	—	—	—	—	—	
H'FFE05	—		—	—	—	—	—	—	—	—	
H'FFE06	—		—	—	—	—	—	—	—	—	
H'FFE07	—		—	—	—	—	—	—	—	—	
H'FFE08	—		—	—	—	—	—	—	—	—	
H'FFE09	—		—	—	—	—	—	—	—	—	
H'FFE0A	—		—	—	—	—	—	—	—	—	
H'FFE0B	—		—	—	—	—	—	—	—	—	
H'FFE0C	—		—	—	—	—	—	—	—	—	
H'FFE0D	—		—	—	—	—	—	—	—	—	
H'FFE0E	—		—	—	—	—	—	—	—	—	
H'FFE0F	—		—	—	—	—	—	—	—	—	

Address (Low)	Register Name	Data Bus Width	Bit Names								Module Name
			Bit 7	Bit 6	Bit 5	Bit 4	Bit 3	Bit 2	Bit 1	Bit 0	
H'FFE10	—	—	—	—	—	—	—	—	—	—	—
H'FFE11	—	—	—	—	—	—	—	—	—	—	—
H'FFE12	—	—	—	—	—	—	—	—	—	—	—
H'FFE13	—	—	—	—	—	—	—	—	—	—	—
H'FFE14	—	—	—	—	—	—	—	—	—	—	—
H'FFE15	—	—	—	—	—	—	—	—	—	—	—
H'FFE16	—	—	—	—	—	—	—	—	—	—	—
H'FFE17	—	—	—	—	—	—	—	—	—	—	—
H'FFE18	—	—	—	—	—	—	—	—	—	—	—
H'FFE19	—	—	—	—	—	—	—	—	—	—	—
H'FFE1A	—	—	—	—	—	—	—	—	—	—	—
H'FFE1B	—	—	—	—	—	—	—	—	—	—	—
H'FFE1C	—	—	—	—	—	—	—	—	—	—	—
H'FFE1D	—	—	—	—	—	—	—	—	—	—	—
H'FFE1E	—	—	—	—	—	—	—	—	—	—	—
H'FFE1F	—	—	—	—	—	—	—	—	—	—	—
H'FFE20	—	—	—	—	—	—	—	—	—	—	—
H'FFE21	—	—	—	—	—	—	—	—	—	—	—
H'FFE22	—	—	—	—	—	—	—	—	—	—	—
H'FFE23	—	—	—	—	—	—	—	—	—	—	—
H'FFE24	—	—	—	—	—	—	—	—	—	—	—
H'FFE25	—	—	—	—	—	—	—	—	—	—	—
H'FFE26	—	—	—	—	—	—	—	—	—	—	—
H'FFE27	—	—	—	—	—	—	—	—	—	—	—
H'FFE28	—	—	—	—	—	—	—	—	—	—	—
H'FFE29	—	—	—	—	—	—	—	—	—	—	—
H'FFE2A	—	—	—	—	—	—	—	—	—	—	—
H'FFE2B	—	—	—	—	—	—	—	—	—	—	—
H'FFE2C	—	—	—	—	—	—	—	—	—	—	—
H'FFE2D	—	—	—	—	—	—	—	—	—	—	—
H'FFE2E	—	—	—	—	—	—	—	—	—	—	—
H'FFE2F	—	—	—	—	—	—	—	—	—	—	—

Address (Low)	Register Name	Data Bus Width	Bit Names								Module Name
			Bit 7	Bit 6	Bit 5	Bit 4	Bit 3	Bit 2	Bit 1	Bit 0	
H'FFE30	—	—	—	—	—	—	—	—	—	—	—
H'FFE31	—	—	—	—	—	—	—	—	—	—	—
H'FFE32	—	—	—	—	—	—	—	—	—	—	—
H'FFE33	—	—	—	—	—	—	—	—	—	—	—
H'FFE34	—	—	—	—	—	—	—	—	—	—	—
H'FFE35	—	—	—	—	—	—	—	—	—	—	—
H'FFE36	—	—	—	—	—	—	—	—	—	—	—
H'FFE37	—	—	—	—	—	—	—	—	—	—	—
H'FFE38	—	—	—	—	—	—	—	—	—	—	—
H'FFE39	—	—	—	—	—	—	—	—	—	—	—
H'FFE3A	—	—	—	—	—	—	—	—	—	—	—
H'FFE3B	—	—	—	—	—	—	—	—	—	—	—
H'FFE3C	—	—	—	—	—	—	—	—	—	—	—
H'FFE3D	—	—	—	—	—	—	—	—	—	—	—
H'FFE3E	—	—	—	—	—	—	—	—	—	—	—
H'FFE3F	—	—	—	—	—	—	—	—	—	—	—
H'FFE40	—	—	—	—	—	—	—	—	—	—	—
H'FFE41	—	—	—	—	—	—	—	—	—	—	—
H'FFE42	—	—	—	—	—	—	—	—	—	—	—
H'FFE43	—	—	—	—	—	—	—	—	—	—	—
H'FFE44	—	—	—	—	—	—	—	—	—	—	—
H'FFE45	—	—	—	—	—	—	—	—	—	—	—
H'FFE46	—	—	—	—	—	—	—	—	—	—	—
H'FFE47	—	—	—	—	—	—	—	—	—	—	—
H'FFE48	—	—	—	—	—	—	—	—	—	—	—
H'FFE49	—	—	—	—	—	—	—	—	—	—	—
H'FFE4A	—	—	—	—	—	—	—	—	—	—	—
H'FFE4B	—	—	—	—	—	—	—	—	—	—	—
H'FFE4C	—	—	—	—	—	—	—	—	—	—	—
H'FFE4D	—	—	—	—	—	—	—	—	—	—	—
H'FFE4E	—	—	—	—	—	—	—	—	—	—	—
H'FFE4F	—	—	—	—	—	—	—	—	—	—	—

Address (Low)	Register Name	Data Bus Width	Bit Names								Module Name	
			Bit 7	Bit 6	Bit 5	Bit 4	Bit 3	Bit 2	Bit 1	Bit 0		
H'FFE50	—	—	—	—	—	—	—	—	—	—	—	—
H'FFE51	—	—	—	—	—	—	—	—	—	—	—	—
H'FFE52	—	—	—	—	—	—	—	—	—	—	—	—
H'FFE53	—	—	—	—	—	—	—	—	—	—	—	—
H'FFE54	—	—	—	—	—	—	—	—	—	—	—	—
H'FFE55	—	—	—	—	—	—	—	—	—	—	—	—
H'FFE56	—	—	—	—	—	—	—	—	—	—	—	—
H'FFE57	—	—	—	—	—	—	—	—	—	—	—	—
H'FFE58	—	—	—	—	—	—	—	—	—	—	—	—
H'FFE59	—	—	—	—	—	—	—	—	—	—	—	—
H'FFE5A	—	—	—	—	—	—	—	—	—	—	—	—
H'FFE5B	—	—	—	—	—	—	—	—	—	—	—	—
H'FFE5C	—	—	—	—	—	—	—	—	—	—	—	—
H'FFE5D	—	—	—	—	—	—	—	—	—	—	—	—
H'FFE5E	—	—	—	—	—	—	—	—	—	—	—	—
H'FFE5F	—	—	—	—	—	—	—	—	—	—	—	—
H'FFE60	—	—	—	—	—	—	—	—	—	—	—	—
H'FFE61	—	—	—	—	—	—	—	—	—	—	—	—
H'FFE62	—	—	—	—	—	—	—	—	—	—	—	—
H'FFE63	—	—	—	—	—	—	—	—	—	—	—	—
H'FFE64	—	—	—	—	—	—	—	—	—	—	—	—
H'FFE65	—	—	—	—	—	—	—	—	—	—	—	—
H'FFE66	—	—	—	—	—	—	—	—	—	—	—	—
H'FFE67	—	—	—	—	—	—	—	—	—	—	—	—
H'FFE68	—	—	—	—	—	—	—	—	—	—	—	—
H'FFE69	—	—	—	—	—	—	—	—	—	—	—	—
H'FFE6A	—	—	—	—	—	—	—	—	—	—	—	—
H'FFE6B	—	—	—	—	—	—	—	—	—	—	—	—
H'FFE6C	—	—	—	—	—	—	—	—	—	—	—	—
H'FFE6D	—	—	—	—	—	—	—	—	—	—	—	—
H'FFE6E	—	—	—	—	—	—	—	—	—	—	—	—
H'FFE6F	—	—	—	—	—	—	—	—	—	—	—	—

Address (Low)	Register Name	Data Bus Width	Bit Names								Module Name
			Bit 7	Bit 6	Bit 5	Bit 4	Bit 3	Bit 2	Bit 1	Bit 0	
H'FFE70	—	—	—	—	—	—	—	—	—	—	—
H'FFE71	—	—	—	—	—	—	—	—	—	—	—
H'FFE72	—	—	—	—	—	—	—	—	—	—	—
H'FFE73	—	—	—	—	—	—	—	—	—	—	—
H'FFE74	—	—	—	—	—	—	—	—	—	—	—
H'FFE75	—	—	—	—	—	—	—	—	—	—	—
H'FFE76	—	—	—	—	—	—	—	—	—	—	—
H'FFE77	—	—	—	—	—	—	—	—	—	—	—
H'FFE78	—	—	—	—	—	—	—	—	—	—	—
H'FFE79	—	—	—	—	—	—	—	—	—	—	—
H'FFE7A	—	—	—	—	—	—	—	—	—	—	—
H'FFE7B	—	—	—	—	—	—	—	—	—	—	—
H'FFE7C	—	—	—	—	—	—	—	—	—	—	—
H'FFE7D	—	—	—	—	—	—	—	—	—	—	—
H'FFE7E	—	—	—	—	—	—	—	—	—	—	—
H'FFE7F	—	—	—	—	—	—	—	—	—	—	—
H'FFE80	MAR0AR	8									DMAC channel 0A
H'FFE81	MAR0AE	8									
H'FFE82	MAR0AH	8									
H'FFE83	MAR0AL	8									
H'FFE84	ETCR0AH	8									
H'FFE85	ETCR0AL	8									
H'FFE86	IOAR0A	8									
H'FFE87	DTCR0A	8	DTE	DTSZ	DTID	RPE	DTIE	DTS2	DTS1	DTS0	Short address mode
			DTE	DTSZ	SAID	SAIDE	DTIE	DTS2A	DTS1A	DTS0A	Full address mode
H'FFE88	MAR0BR	8									DMAC channel 0B
H'FFE89	MAR0BE	8									
H'FFE8A	MAR0BH	8									
H'FFE8B	MAR0BL	8									
H'FFE8C	ETCR0BH	8									
H'FFE8D	ETCR0BL	8									
H'FFE8E	IOAR0B	8									
H'FFE8F	DTCR0B	8	DTE	DTSZ	DTID	RPE	DTIE	DTS2	DTS1	DTS0	Short address mode
			DTME	—	DAID	DAIDE	TMS	DTS2B	DTS1B	DTS0B	Full address mode

Appendix B Internal I/O Registers

Address (Low)	Register Name	Data Bus Width	Bit Names								Module Name	
			Bit 7	Bit 6	Bit 5	Bit 4	Bit 3	Bit 2	Bit 1	Bit 0		
H'FFE90	MAR1AR	8										DMAC channel 1A
H'FFE91	MAR1AE	8										
H'FFE92	MAR1AH	8										
H'FFE93	MAR1AL	8										
H'FFE94	ETCR1AH	8										
H'FFE95	ETCR1AL	8										
H'FFE96	IOAR1A	8										
H'FFE97	DTCR1A	8	DTE	DTSZ	DTID	RPE	DTIE	DTS2	DTS1	DTS0	Short address mode	
			DTE	DTSZ	SAID	SAIDE	DTIE	DTS2A	DTS1A	DTS0A	Full address mode	
H'FFE98	MAR1BR	8										DMAC channel 1B
H'FFE99	MAR1BE	8										
H'FFE9A	MAR1BH	8										
H'FFE9B	MAR1BL	8										
H'FFE9C	ETCR1BH	8										
H'FFE9D	ETCR1BL	8										
H'FFE9E	IOAR1B	8										
H'FFE9F	DTCR1B	8	DTE	DTSZ	DTID	RPE	DTIE	DTS2	DTS1	DTS0	Short address mode	
			DTME	—	DAID	DAIDE	TMS	DTS2B	DTS1B	DTS0B	Full address mode	
H'FFEA0	TSTR	8	—	—	—	—	—	STR2	STR1	STR0	16-bit timer, (all channels)	
H'FFEA1	TSNC	8	—	—	—	—	—	SYNC2	SYNC1	SYNC0		
H'FFEA2	TMDR	8	—	MDF	FDIR	—	—	PWM2	PWM1	PWM0		
H'FFEA3	TOLR	8	—	—	TOB2	TOA2	TOB1	TOA1	TOB0	TOA0		
H'FFEA4	TISRA	8	—	IMIEA2	IMIEA1	IMIEA0	—	IMFA2	IMFA1	IMFA0		
H'FFEA5	TISRB	8	—	IMIEB2	IMIEB1	IMIEB0	—	IMFB2	IMFB1	IMFB0		
H'FFEA6	TISRC	8	—	OVIE2	OVIE1	OVIE0	—	OVF2	OVF1	OVF0		
H'FFEA7	—											
H'FFEA8	16TCR0	8	—	CCLR1	CCLR0	CKEG1	CKEG0	TPSC2	TPSC1	TPSC0	16-bit timer channel 0	
H'FFEA9	TIOR0	8	—	IOB2	IOB1	IOB0	—	IOA2	IOA1	IOA0		
H'FFEAA	16TCNT0H	16										
H'FFEAB	16TCNT0L											
H'FFEAC	GRA0H	16										
H'FFEAD	GRA0L											
H'FFEAE	GRB0H	16										
H'FFEAF	GRB0L											

Address (Low)	Register Name	Data Bus Width	Bit Names								Module Name
			Bit 7	Bit 6	Bit 5	Bit 4	Bit 3	Bit 2	Bit 1	Bit 0	
H'FFEB0	16TCR1	8	—	CCLR1	CCLR0	CKEG1	CKEG0	TPSC2	TPSC1	TPSC0	16-bit timer channel 1
H'FFEB1	TIOR1	8	—	IOB2	IOB1	IOB0	—	IOA2	IOA1	IOA0	
H'FFEB2	16TCNT1H	16									
H'FFEB3	16TCNT1L										
H'FFEB4	GRA1H	16									
H'FFEB5	GRA1L										
H'FFEB6	GRB1H	16									
H'FFEB7	GRB1L										
H'FFEB8	16TCR2	8	—	CCLR1	CCLR0	CKEG1	CKEG0	TPSC2	TPSC1	TPSC0	16-bit timer channel 2
H'FFEB9	TIOR2	8	—	IOB2	IOB1	IOB0	—	IOA2	IOA1	IOA0	
H'FFEBA	16TCNT2H	16									
H'FFEBB	16TCNT2L										
H'FFEBC	GRA2H	16									
H'FFEBD	GRA2L										
H'FFEBE	GRB2H	16									
H'FFEBF	GRB2L										
H'FFEC0	8TCR0	8	CMIEB	CMIEA	OVIE	CCLR1	CCLR0	CKS2	CKS1	CKS0	8-bit timer channels 0 and 1
H'FFEC1	8TCR1	8	CMIEB	CMIEA	OVIE	CCLR1	CCLR0	CKS2	CKS1	CKS0	
H'FFEC2	8TCSR0	8	CMFB	CMFA	OVF	ADTE	OIS3	OIS2	OS1	OS0	
H'FFEC3	8TCSR1	8	CMFB	CMFA	OVF	ICE	OIS3	OIS2	OS1	OS0	
H'FFEC4	TCORA0	8									
H'FFEC5	TCORA1	8									
H'FFEC6	TCORB0	8									
H'FFEC7	TCORB1	8									
H'FFEC8	8TCNT0	8									
H'FFEC9	8TCNT1	8									
H'FFECA	Reserved area (access prohibited)										
H'FFECB											
H'FFECC											
H'FFECD											
H'FFECE											
H'FFECF											

Appendix B Internal I/O Registers

Address (Low)	Register Name	Data Bus Width	Bit Names								Module Name
			Bit 7	Bit 6	Bit 5	Bit 4	Bit 3	Bit 2	Bit 1	Bit 0	
H'FFED0	8TCR2	8	CMIEB	CMIEA	OVIE	CCLR1	CCLR0	CKS2	CKS1	CKS0	8-bit timer channels 2 and 3
H'FFED1	8TCR3	8	CMIEB	CMIEA	OVIE	CCLR1	CCLR0	CKS2	CKS1	CKS0	
H'FFED2	8TCSR2	8	CMFB	CMFA	OVF	—	OIS3	OIS2	OS1	OS0	
H'FFED3	8TCSR3	8	CMFB	CMFA	OVF	ICE	OIS3	OIS2	OS1	OS0	
H'FFED4	TCORA2	8									
H'FFED5	TCORA3	8									
H'FFED6	TCORB2	8									
H'FFED7	TCORB3	8									
H'FFED8	8TCNT2	8									
H'FFED9	8TCNT3	8									
H'FFEDA	Reserved area (access prohibited)										
H'FFEDB											
H'FFEDC											
H'FFEDD											
H'FFEDE											
H'FFEDF											
H'FFEE0	SMR	8	C/ \bar{A}	CHR	PE	O/ \bar{E}	STOP	MP	CKS1	CKS0	SCI channel 0
H'FFEE1	BRR	8									
H'FFEE2	SCR	8	TIE	RIE	TE	RE	MPIE	TEIE	CKE1	CKE0	
H'FFEE3	TDR	8									
H'FFEE4	SSR	8	TDRE	RDRF	ORER	FER/ ERS	PER	TEND	MPB	MPBT	
H'FFEE5	RDR	8									
H'FFEE6	SCMR	8	—	—	—	—	SDIR	SINV	—	SMIF	
H'FFEE7	—		—	—	—	—	—	—	—	—	
H'FFEE8	SMR	8	C/ \bar{A}	CHR	PE	O/ \bar{E}	STOP	MP	CKS1	CKS0	SCI channel 1
H'FFEE9	BRR	8									
H'FFEEA	SCR	8	TIE	RIE	TE	RE	MPIE	TEIE	CKE1	CKE0	
H'FFEEB	TDR	8									
H'FFEEC	SSR	8	TDRE	RDRF	ORER	FER/ ERS	PER	TEND	MPB	MPBT	
H'FFEED	RDR	8									
H'FFEEE	SCMR	8	—	—	—	—	SDIR	SINV	—	SMIF	
H'FFEEF	—		—	—	—	—	—	—	—	—	

Address (Low)	Register Name	Data Bus Width	Bit Names								Module Name
			Bit 7	Bit 6	Bit 5	Bit 4	Bit 3	Bit 2	Bit 1	Bit 0	
H'FFFE0	SMR	8	C/ \bar{A}	CHR	PE	O/ \bar{E}	STOP	MP	CKS1	CKS0	SCI channel 2
H'FFFE1	BRR	8									
H'FFFE2	SCR	8	TIE	RIE	TE	RE	MPIE	TEIE	CKE1	CKE0	
H'FFFE3	TDR	8									
H'FFFE4	SSR	8	TDRE	RDRF	ORER	FER/ ERS	PER	TEND	MPB	MPBT	
H'FFFE5	RDR	8									
H'FFFE6	SCMR	8	—	—	—	—	SDIR	SINV	—	SMIF	
H'FFFE7	—	—	—	—	—	—	—	—	—	—	
H'FFFE8	TPMR	8	—	—	—	—	G3NOV	G2NOV	G1NOV	G0NOV	
H'FFFE9	TPCR	8	G3CMS1	G3CMS0	G2CMS1	G2CMS0	G1CMS1	G1CMS0	G0CMS1	G0CMS0	
H'FFFEA	NDERB	8	NDER15	NDER14	NDER13	NDER12	NDER11	NDER10	NDER9	NDER8	
H'FFFEFB	NDERA	8	NDER7	NDER6	NDER5	NDER4	NDER3	NDER2	NDER1	NDER0	
H'FFFEFC	NDRB* ³	8	NDR15	NDR14	NDR13	NDR12	NDR11	NDR10	NDR9	NDR8	
			NDR15	NDR14	NDR13	NDR12	—	—	—	—	
H'FFFEFD	NDRA* ³	8	NDR7	NDR6	NDR5	NDR4	NDR3	NDR2	NDR1	NDR0	
			NDR7	NDR6	NDR5	NDR4	—	—	—	—	
H'FFFEFE	NDRB* ³	8	—	—	—	—	—	—	—	—	
			—	—	—	—	NDR11	NDR10	NDR9	NDR8	
H'FFFEFF	NDRA* ³	8	—	—	—	—	—	—	—	—	
			—	—	—	—	NDR3	NDR2	NDR1	NDR0	
H'FFFE0	ADDRAH	8	AD9	AD8	AD7	AD6	AD5	AD4	AD3	AD2	A/D converter
H'FFFE1	ADDRAL	8	AD1	AD0	—	—	—	—	—	—	
H'FFFE2	ADDRBH	8	AD9	AD8	AD7	AD6	AD5	AD4	AD3	AD2	
H'FFFE3	ADDRBL	8	AD1	AD0	—	—	—	—	—	—	
H'FFFE4	ADDRCH	8	AD9	AD8	AD7	AD6	AD5	AD4	AD3	AD2	
H'FFFE5	ADDRCL	8	AD1	AD0	—	—	—	—	—	—	
H'FFFE6	ADDRDH	8	AD9	AD8	AD7	AD6	AD5	AD4	AD3	AD2	
H'FFFE7	ADDRDL	8	AD1	AD0	—	—	—	—	—	—	
H'FFFE8	ADCSR	8	ADF	ADIE	ADST	SCAN	CKS	CH2	CH1	CH0	
H'FFFE9	ADCR	8	TRGE	—	—	—	—	—	—	—	
H'FFFEA	Reserved area (access prohibited)										
H'FFFEB											
H'FFFE0	DADR0	8									D/A converter
H'FFFE1	DADR1	8									
H'FFFE2	DACR	8	—	—	—	—	—	—	—	—	
H'FFFE3	—	8	—	—	—	—	—	—	—	—	

Address (Low)	Register Name	Data Bus Width	Bit Names								Module Name
			Bit 7	Bit 6	Bit 5	Bit 4	Bit 3	Bit 2	Bit 1	Bit 0	
H'FFFF0	P1DR	8	P1 ₇	P1 ₆	P1 ₅	P1 ₄	P1 ₃	P1 ₂	P1 ₁	P1 ₀	Port1
H'FFFF1	P2DR	8	P2 ₇	P2 ₆	P2 ₅	P2 ₄	P2 ₃	P2 ₂	P2 ₁	P2 ₀	Port2
H'FFFF2	P3DR	8	P3 ₇	P3 ₆	P3 ₅	P3 ₄	P3 ₃	P3 ₂	P3 ₁	P3 ₀	Port3
H'FFFF3	P4DR	8	P4 ₇	P4 ₆	P4 ₅	P4 ₄	P4 ₃	P4 ₂	P4 ₁	P4 ₀	Port4
H'FFFF4	P5DR	8	—	—	—	—	P5 ₃	P5 ₂	P5 ₁	P5 ₀	Port5
H'FFFF5	P6DR	8	P6 ₇	P6 ₆	P6 ₅	P6 ₄	P6 ₃	P6 ₂	P6 ₁	P6 ₀	Port6
H'FFFF6	P7DR	8	P7 ₇	P7 ₆	P7 ₅	P7 ₄	P7 ₃	P7 ₂	P7 ₁	P7 ₀	Port7
H'FFFF7	P8DR	8	—	—	—	P8 ₄	P8 ₃	P8 ₂	P8 ₁	P8 ₀	Port8
H'FFFF8	P9DR	8	—	—	P9 ₅	P9 ₄	P9 ₃	P9 ₂	P9 ₁	P9 ₀	Port9
H'FFFF9	PADR	8	PA ₇	PA ₆	PA ₅	PA ₄	PA ₃	PA ₂	PA ₁	PA ₀	PortA
H'FFFFA	PBDR	8	PB ₇	PB ₆	PB ₅	PB ₄	PB ₃	PB ₂	PB ₁	PB ₀	PortB
H'FFFFB	—	—	—	—	—	—	—	—	—	—	—
H'FFFFC	—	—	—	—	—	—	—	—	—	—	—
H'FFFFD	—	—	—	—	—	—	—	—	—	—	—
H'FFFFE	—	—	—	—	—	—	—	—	—	—	—
H'FFFFF	—	—	—	—	—	—	—	—	—	—	—

- Notes:
1. The RAMCR and FLMCR registers are used only in the flash memory and flash memory R versions, and are not provided in the mask ROM versions.
 2. For write access to TCSR, TCNT, and RSTCSR, see section 12.2.4, Notes on Register Access.
 3. The address depends on the output trigger setting.

Legend

WDT: Watchdog timer

TPC: Programmable timing pattern controller

SCI: Serial communication interface

B.3 Functions

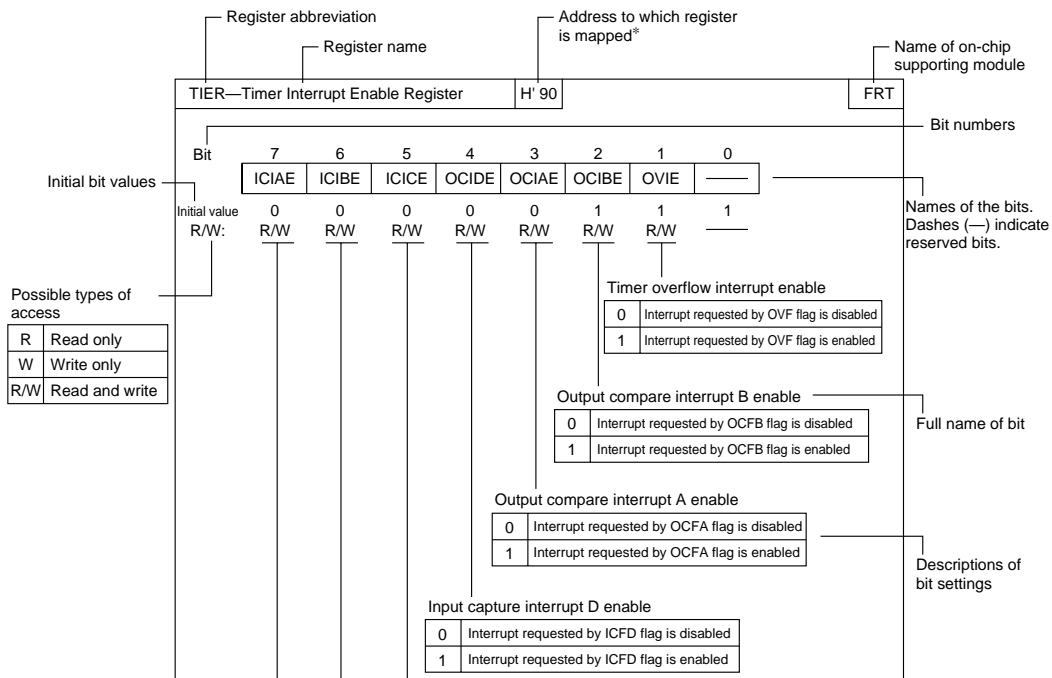

Note: * When the EMC bit in BCR is cleared to 0, addresses of some registers are changed.

P1DDR—Port 1 Data Direction Register						H'EE000	Port 1	
Bit	7	6	5	4	3	2	1	0
	P17DDR	P16DDR	P15DDR	P14DDR	P13DDR	P12DDR	P11DDR	P10DDR
Modes 1 to 4	Initial value		1	1	1	1	1	1
	Read/Write		—	—	—	—	—	—
Modes 5 to 7	Initial value		0	0	0	0	0	0
	Read/Write		W	W	W	W	W	W
Port 1 input/output select								
		0	Generic input					
		1	Generic output					

P2DDR—Port 2 Data Direction Register						H'EE001	Port 2	
Bit	7	6	5	4	3	2	1	0
	P27DDR	P26DDR	P25DDR	P24DDR	P23DDR	P22DDR	P21DDR	P20DDR
Modes 1 to 4	Initial value		1	1	1	1	1	1
	Read/Write		—	—	—	—	—	—
Modes 5 to 7	Initial value		0	0	0	0	0	0
	Read/Write		W	W	W	W	W	W
Port 2 input/output select								
		0	Generic input					
		1	Generic output					

P3DDR—Port 3 Data Direction Register						H'EE002	Port 3					
Bit	7	6	5	4	3	2	1	0				
	P37DDR	P36DDR	P35DDR	P34DDR	P33DDR	P32DDR	P31DDR	P30DDR				
Initial value	0	0	0	0	0	0	0	0				
Read/Write	W	W	W	W	W	W	W	W				
Port 3 input/output select <table border="1"> <tr> <td>0</td> <td>Generic input</td> </tr> <tr> <td>1</td> <td>Generic output</td> </tr> </table>									0	Generic input	1	Generic output
0	Generic input											
1	Generic output											

P4DDR—Port 4 Data Direction Register						H'EE003	Port 4					
Bit	7	6	5	4	3	2	1	0				
	P47DDR	P46DDR	P45DDR	P44DDR	P43DDR	P42DDR	P41DDR	P40DDR				
Initial value	0	0	0	0	0	0	0	0				
Read/Write	W	W	W	W	W	W	W	W				
Port 4 input/output select <table border="1"> <tr> <td>0</td> <td>Generic input</td> </tr> <tr> <td>1</td> <td>Generic output</td> </tr> </table>									0	Generic input	1	Generic output
0	Generic input											
1	Generic output											

P5DDR—Port 5 Data Direction Register					H'EE004	Port 5		
Bit	7	6	5	4	3	2	1	0
	—	—	—	—	P5 ₃ DDR	P5 ₂ DDR	P5 ₁ DDR	P5 ₀ DDR
Modes 1 to 4	Initial value	1	1	1	1	1	1	1
	Read/Write	—	—	—	—	—	—	—
Modes 5 to 7	Initial value	1	1	1	0	0	0	0
	Read/Write	—	—	—	W	W	W	W
					Port 5 input/output select			
					0	Generic input pin		
					1	Generic output pin		

P6DDR—Port 6 Data Direction Register					H'EE005	Port 6		
Bit	7	6	5	4	3	2	1	0
	—	P6 ₆ DDR	P6 ₅ DDR	P6 ₄ DDR	P6 ₃ DDR	P6 ₂ DDR	P6 ₁ DDR	P6 ₀ DDR
Initial value	1	0	0	0	0	0	0	0
Read/Write	—	W	W	W	W	W	W	W
					Port 6 input/output select			
					0	Generic input		
					1	Generic output		

P8DDR—Port 8 Data Direction Register				H'EE007			Port 8	
Bit	7	6	5	4	3	2	1	0
	—	—	—	P8 ₄ DDR	P8 ₃ DDR	P8 ₂ DDR	P8 ₁ DDR	P8 ₀ DDR
Modes 1 to 4	Initial value	1	1	1	0	0	0	0
	Read/Write	—	—	—	W	W	W	W
Modes 5 to 7	Initial value	1	1	1	0	0	0	0
	Read/Write	—	—	—	W	W	W	W

Port 8 input/output select

0	Generic input
1	Generic output

P9DDR—Port 9 Data Direction Register		H'EE008		Port 9								
Bit	7	6	5	4	3	2	1	0				
	—	—	P9 ₅ DDR	P9 ₄ DDR	P9 ₃ DDR	P9 ₂ DDR	P9 ₁ DDR	P9 ₀ DDR				
Initial value	1	1	0	0	0	0	0	0				
Read/Write	—	—	W	W	W	W	W	W				
Port 9 input/output select												
<table border="1"> <tr> <td>0</td> <td>Generic input</td> </tr> <tr> <td>1</td> <td>Generic output</td> </tr> </table>									0	Generic input	1	Generic output
0	Generic input											
1	Generic output											

PADDR—Port A Data Direction Register		H'EE009		Port A								
Bit	7	6	5	4	3	2	1	0				
	PA ₇ DDR	PA ₆ DDR	PA ₅ DDR	PA ₄ DDR	PA ₃ DDR	PA ₂ DDR	PA ₁ DDR	PA ₀ DDR				
Modes 3, 4	Initial value Read/Write	1	0	0	0	0	0	0				
		—	W	W	W	W	W	W				
Modes 1, 2, 5, 6, 7	Initial value Read/Write	0	0	0	0	0	0	0				
		W	W	W	W	W	W	W				
Port A input/output select												
<table border="1"> <tr> <td>0</td> <td>Generic input</td> </tr> <tr> <td>1</td> <td>Generic output</td> </tr> </table>									0	Generic input	1	Generic output
0	Generic input											
1	Generic output											

PBDDR—Port B Data Direction Register		H'EE00A		Port B								
Bit	7	6	5	4	3	2	1	0				
	PB ₇ DDR	PB ₆ DDR	PB ₅ DDR	PB ₄ DDR	PB ₃ DDR	PB ₂ DDR	PB ₁ DDR	PB ₀ DDR				
Initial value	0	0	0	0	0	0	0	0				
Read/Write	W	W	W	W	W	W	W	W				
Port B input/output select												
<table border="1"> <tr> <td>0</td> <td>Generic input</td> </tr> <tr> <td>1</td> <td>Generic output</td> </tr> </table>									0	Generic input	1	Generic output
0	Generic input											
1	Generic output											

MDCR—Mode Control Register					H'EE011	System control		
Bit	7	6	5	4	3	2	1	0
	—	—	—	—	—	MDS2	MDS1	MDS0
Initial value	1	1	0	0	0	—*	—*	—*
Read/Write	—	—	—	—	—	R	R	R

Mode select 2 to 0

Bit 2	Bit 1	Bit 0	Operating Mode
MD ₂	MD ₁	MD ₀	
0	0	0	—
		1	Mode 1
	1	0	Mode 2
		1	Mode 3
1	0	0	Mode 4
		1	Mode 5
	1	0	Mode 6
		1	Mode 7

Note: * Determined by the state of the mode pins (MD₂ to MD₀).

SYSCR—System Control Register					H'EE012	System control		
Bit	7	6	5	4	3	2	1	0
	SSBY	STS2	STS1	STS0	UE	NMIEG	SSOE	RAME
Initial value	0	0	0	0	1	0	0	1
Read/Write	R/W	R/W	R/W	R/W	R/W	R/W	R/W	R/W
								RAM enable
								0 On-chip RAM is disabled
								1 On-chip RAM is enabled
								Software standby output port enable
							0	In software standby mode, all address bus and bus control signals are high-impedance
							1	In software standby mode, address bus retains output state and bus control signals are fixed high
								NMI edge select
							0	An interrupt is requested at the falling edge of NMI
							1	An interrupt is requested at the rising edge of NMI
								User bit enable
							0	CCR bit 6 (UI) is used as an interrupt mask bit
							1	CCR bit 6 (UI) is used as a user bit
								Standby timer select 2 to 0
	Bit 6	Bit 5	Bit 4	Standby Timer				
	STS2	STS1	STS0					
	0	0	0	Waiting Time = 8,192 states				
			1	Waiting Time = 16,384 states				
		1	0	Waiting Time = 32,768 states				
			1	Waiting Time = 65,536 states				
	1	0	0	Waiting Time = 131,072 states				
			1	Waiting Time = 26,2144 states				
		1	0	Waiting Time = 1,024 states				
			1	Illegal setting				
								Software standby
	0	SLEEP instruction causes transition to sleep mode						
	1	SLEEP instruction causes transition to software standby mode						

BRCR—Bus Release Control Register				H'EE013	Bus controller			
Bit	7	6	5	4	3	2	1	0
	A23E	A22E	A21E	A20E	—	—	—	BRLE
Modes 1, 2, 6, 7	Initial value	1	1	1	1	1	1	0
	Read/Write	—	—	—	—	—	—	R/W
Modes 3, 4	Initial value	1	1	1	0	1	1	0
	Read/Write	R/W	R/W	R/W	—	—	—	R/W
Mode 5	Initial value	1	1	1	1	1	1	0
	Read/Write	R/W	R/W	R/W	—	—	—	R/W
Address 23 to 20 enable				Bus release enable				
	0	Address output			0	The bus cannot be released to an external device		
	1	Other input/output			1	The bus can be released to an external device		

ISCR—IRQ Sense Control Register				H'EE014	Interrupt Controller			
Bit	7	6	5	4	3	2	1	0
	—	—	IRQ5SC	IRQ4SC	IRQ3SC	IRQ2SC	IRQ1SC	IRQ0SC
Initial value	0	0	0	0	0	0	0	0
Read/Write	R/W	R/W	R/W	R/W	R/W	R/W	R/W	R/W
IRQ ₅ to IRQ ₀ sense control								
	0	Interrupts are requested when \overline{IRQ}_5 to \overline{IRQ}_0 are low						
	1	Interrupts are requested by falling-edge input at \overline{IRQ}_5 to \overline{IRQ}_0						

IER—IRQ Enable Register		H'EE015	Interrupt Controller													
Bit	7	6	5	4	3	2	1	0								
	—	—	IRQ5E	IRQ4E	IRQ3E	IRQ2E	IRQ1E	IRQ0E								
Initial value	0	0	0	0	0	0	0	0								
Read/Write	R/W	R/W	R/W	R/W	R/W	R/W	R/W	R/W								
			↓ IRQ ₅ to IRQ ₀ enable													
			<table border="1"> <tr> <td>0</td> <td>IRQ₅ to IRQ₀ interrupts are disabled</td> </tr> <tr> <td>1</td> <td>IRQ₅ to IRQ₀ interrupts are enabled</td> </tr> </table>						0	IRQ ₅ to IRQ ₀ interrupts are disabled	1	IRQ ₅ to IRQ ₀ interrupts are enabled				
0	IRQ ₅ to IRQ ₀ interrupts are disabled															
1	IRQ ₅ to IRQ ₀ interrupts are enabled															
ISR—IRQ Status Register		H'EE016	Interrupt Controller													
Bit	7	6	5	4	3	2	1	0								
	—	—	IRQ5F	IRQ4F	IRQ3F	IRQ2F	IRQ1F	IRQ0F								
Initial value	0	0	0	0	0	0	0	0								
Read/Write	—	—	R/(W)*	R/(W)*	R/(W)*	R/(W)*	R/(W)*	R/(W)*								
			↓ IRQ ₅ to IRQ ₀ flags													
			<table border="1"> <thead> <tr> <th>Bits 5 to 0</th> <th>Setting and Clearing Conditions</th> </tr> </thead> <tbody> <tr> <td>IRQ5F to IRQ0F</td> <td></td> </tr> <tr> <td>0</td> <td> [Clearing conditions] <ul style="list-style-type: none"> Read IRQ_nF when IRQ_nF = 1, then write 0 in IRQ_nF. IRQ_nSC = 0, $\overline{\text{IRQ}}_n$ input is high, and interrupt exception handling is being carried out. IRQ_nSC = 1 and IRQ_n interrupt exception handling is being carried out. </td> </tr> <tr> <td>1</td> <td> [Setting conditions] <ul style="list-style-type: none"> IRQ_nSC = 0 and $\overline{\text{IRQ}}_n$ input is low. IRQ_nSC = 1 and $\overline{\text{IRQ}}_n$ input changes from high to low. </td> </tr> </tbody> </table>						Bits 5 to 0	Setting and Clearing Conditions	IRQ5F to IRQ0F		0	[Clearing conditions] <ul style="list-style-type: none"> Read IRQ_nF when IRQ_nF = 1, then write 0 in IRQ_nF. IRQ_nSC = 0, $\overline{\text{IRQ}}_n$ input is high, and interrupt exception handling is being carried out. IRQ_nSC = 1 and IRQ_n interrupt exception handling is being carried out. 	1	[Setting conditions] <ul style="list-style-type: none"> IRQ_nSC = 0 and $\overline{\text{IRQ}}_n$ input is low. IRQ_nSC = 1 and $\overline{\text{IRQ}}_n$ input changes from high to low.
Bits 5 to 0	Setting and Clearing Conditions															
IRQ5F to IRQ0F																
0	[Clearing conditions] <ul style="list-style-type: none"> Read IRQ_nF when IRQ_nF = 1, then write 0 in IRQ_nF. IRQ_nSC = 0, $\overline{\text{IRQ}}_n$ input is high, and interrupt exception handling is being carried out. IRQ_nSC = 1 and IRQ_n interrupt exception handling is being carried out. 															
1	[Setting conditions] <ul style="list-style-type: none"> IRQ_nSC = 0 and $\overline{\text{IRQ}}_n$ input is low. IRQ_nSC = 1 and $\overline{\text{IRQ}}_n$ input changes from high to low. 															
			(n = 5 to 0)													
Note: * Only 0 can be written, to clear the flag.																

IPRA—Interrupt Priority Register A				H'EE018		Interrupt Controller																																											
<table border="1"> <tr> <td>Bit</td> <td>7</td> <td>6</td> <td>5</td> <td>4</td> <td>3</td> <td>2</td> <td>1</td> <td>0</td> <td></td> </tr> <tr> <td></td> <td>IPRA7</td> <td>IPRA6</td> <td>IPRA5</td> <td>IPRA4</td> <td>IPRA3</td> <td>IPRA2</td> <td>IPRA1</td> <td>IPRA0</td> <td></td> </tr> <tr> <td>Initial value</td> <td>0</td> <td>0</td> <td>0</td> <td>0</td> <td>0</td> <td>0</td> <td>0</td> <td>0</td> <td>0</td> </tr> <tr> <td>Read/Write</td> <td>R/W</td> <td>R/W</td> <td>R/W</td> <td>R/W</td> <td>R/W</td> <td>R/W</td> <td>R/W</td> <td>R/W</td> <td>R/W</td> </tr> </table>										Bit	7	6	5	4	3	2	1	0			IPRA7	IPRA6	IPRA5	IPRA4	IPRA3	IPRA2	IPRA1	IPRA0		Initial value	0	0	0	0	0	0	0	0	0	Read/Write	R/W	R/W	R/W	R/W	R/W	R/W	R/W	R/W	R/W
Bit	7	6	5	4	3	2	1	0																																									
	IPRA7	IPRA6	IPRA5	IPRA4	IPRA3	IPRA2	IPRA1	IPRA0																																									
Initial value	0	0	0	0	0	0	0	0	0																																								
Read/Write	R/W	R/W	R/W	R/W	R/W	R/W	R/W	R/W	R/W																																								
Priority level A7 to A0																																																	
<table border="1"> <tr> <td>0</td> <td>Priority level 0 (low priority)</td> </tr> <tr> <td>1</td> <td>Priority level 1 (high priority)</td> </tr> </table>										0	Priority level 0 (low priority)	1	Priority level 1 (high priority)																																				
0	Priority level 0 (low priority)																																																
1	Priority level 1 (high priority)																																																
<p>• Interrupt sources controlled by each bit</p> <table border="1"> <thead> <tr> <th rowspan="2">IPRA</th> <th rowspan="2">Bit</th> <th>Bit 7</th> <th>Bit 6</th> <th>Bit 5</th> <th>Bit 4</th> <th>Bit 3</th> <th>Bit 2</th> <th>Bit 1</th> <th>Bit 0</th> </tr> <tr> <th>IPRA7</th> <th>IPRA6</th> <th>IPRA5</th> <th>IPRA4</th> <th>IPRA3</th> <th>IPRA2</th> <th>IPRA1</th> <th>IPRA0</th> </tr> </thead> <tbody> <tr> <td></td> <td>Interrupt source</td> <td>IRQ0</td> <td>IRQ1</td> <td>IRQ2, IRQ3</td> <td>IRQ4, IRQ5</td> <td>WDT, DRAM interface, A/D converter</td> <td>16-bit timer channel 0</td> <td>16-bit timer channel 1</td> <td>16-bit timer channel 2</td> </tr> </tbody> </table>										IPRA	Bit	Bit 7	Bit 6	Bit 5	Bit 4	Bit 3	Bit 2	Bit 1	Bit 0	IPRA7	IPRA6	IPRA5	IPRA4	IPRA3	IPRA2	IPRA1	IPRA0		Interrupt source	IRQ0	IRQ1	IRQ2, IRQ3	IRQ4, IRQ5	WDT, DRAM interface, A/D converter	16-bit timer channel 0	16-bit timer channel 1	16-bit timer channel 2												
IPRA	Bit	Bit 7	Bit 6	Bit 5	Bit 4	Bit 3	Bit 2	Bit 1	Bit 0																																								
		IPRA7	IPRA6	IPRA5	IPRA4	IPRA3	IPRA2	IPRA1	IPRA0																																								
	Interrupt source	IRQ0	IRQ1	IRQ2, IRQ3	IRQ4, IRQ5	WDT, DRAM interface, A/D converter	16-bit timer channel 0	16-bit timer channel 1	16-bit timer channel 2																																								
IPRB—Interrupt Priority Register B				H'EE019		Interrupt Controller																																											
<table border="1"> <tr> <td>Bit</td> <td>7</td> <td>6</td> <td>5</td> <td>4</td> <td>3</td> <td>2</td> <td>1</td> <td>0</td> <td></td> </tr> <tr> <td></td> <td>IPRB7</td> <td>IPRB6</td> <td>IPRB5</td> <td>——</td> <td>IPRB3</td> <td>IPRB2</td> <td>IPRB1</td> <td>——</td> <td></td> </tr> <tr> <td>Initial value</td> <td>0</td> <td>0</td> <td>0</td> <td>0</td> <td>0</td> <td>0</td> <td>0</td> <td>0</td> <td>0</td> </tr> <tr> <td>Read/Write</td> <td>R/W</td> <td>R/W</td> <td>R/W</td> <td>R/W</td> <td>R/W</td> <td>R/W</td> <td>R/W</td> <td>R/W</td> <td>R/W</td> </tr> </table>										Bit	7	6	5	4	3	2	1	0			IPRB7	IPRB6	IPRB5	——	IPRB3	IPRB2	IPRB1	——		Initial value	0	0	0	0	0	0	0	0	0	Read/Write	R/W	R/W	R/W	R/W	R/W	R/W	R/W	R/W	R/W
Bit	7	6	5	4	3	2	1	0																																									
	IPRB7	IPRB6	IPRB5	——	IPRB3	IPRB2	IPRB1	——																																									
Initial value	0	0	0	0	0	0	0	0	0																																								
Read/Write	R/W	R/W	R/W	R/W	R/W	R/W	R/W	R/W	R/W																																								
Priority level B7 to B5, B3 to B1																																																	
<table border="1"> <tr> <td>0</td> <td>Priority level 0 (low priority)</td> </tr> <tr> <td>1</td> <td>Priority level 1 (high priority)</td> </tr> </table>										0	Priority level 0 (low priority)	1	Priority level 1 (high priority)																																				
0	Priority level 0 (low priority)																																																
1	Priority level 1 (high priority)																																																
<p>Interrupt sources controlled by each bit</p> <table border="1"> <thead> <tr> <th rowspan="2">IPRB</th> <th rowspan="2">Bit</th> <th>Bit 7</th> <th>Bit 6</th> <th>Bit 5</th> <th>Bit 4</th> <th>Bit 3</th> <th>Bit 2</th> <th>Bit 1</th> <th>Bit 0</th> </tr> <tr> <th>IPRB7</th> <th>IPRB6</th> <th>IPRB5</th> <th>——</th> <th>IPRB3</th> <th>IPRB2</th> <th>IPRB1</th> <th>——</th> </tr> </thead> <tbody> <tr> <td></td> <td>Interrupt source</td> <td>8-bit timer channels 0 and 1</td> <td>8-bit timer channels 2 and 3</td> <td>DMAC</td> <td>——</td> <td>SCI channel 0</td> <td>SCI channel 1</td> <td>SCI channel 2</td> <td>——</td> </tr> </tbody> </table>										IPRB	Bit	Bit 7	Bit 6	Bit 5	Bit 4	Bit 3	Bit 2	Bit 1	Bit 0	IPRB7	IPRB6	IPRB5	——	IPRB3	IPRB2	IPRB1	——		Interrupt source	8-bit timer channels 0 and 1	8-bit timer channels 2 and 3	DMAC	——	SCI channel 0	SCI channel 1	SCI channel 2	——												
IPRB	Bit	Bit 7	Bit 6	Bit 5	Bit 4	Bit 3	Bit 2	Bit 1	Bit 0																																								
		IPRB7	IPRB6	IPRB5	——	IPRB3	IPRB2	IPRB1	——																																								
	Interrupt source	8-bit timer channels 0 and 1	8-bit timer channels 2 and 3	DMAC	——	SCI channel 0	SCI channel 1	SCI channel 2	——																																								

DASTCR—D/A Standby Control Register						H'EE01A	D/A		
Bit	7	6	5	4	3	2	1	0	
	—	—	—	—	—	—	—	DASTE	
Initial value	1	1	1	1	1	1	1	0	
Read/Write	—	—	—	—	—	—	—	R/W	
								D/A standby enable	
								0	D/A output is disabled in software standby mode (Initial value)
								1	D/A output is enabled in software standby mode

DIVCR—Division Control Register						H'EE01B	System control	
Bit	7	6	5	4	3	2	1	0
	_____	_____	_____	_____	_____	_____	DIV1	DIV0
Initial value	1	1	1	1	1	1	0	0
Read/Write	_____	_____	_____	_____	_____	_____	R/W	R/W
							Divide 1 and 0	
		Bit 1	Bit 0	Frequency Division Ratio				
		DIV1	DIV0					
		0	0	1/1 (Initial value)				
			1	1/2				
		1	0	1/4				
			1	1/8				

MSTCRH—Module Standby Control Register H					H'EE01C	System control		
Bit	7	6	5	4	3	2	1	0
	PSTOP	—	—	—	—	MSTPH2	MSTPH1	MSTPH0
Initial value	0	1	1	1	1	0	0	0
Read/Write	R/W	—	—	—	—	R/W	R/W	R/W
	Reserved bits					Module standby H2 to H0 Selection bits for placing modules in standby state.		
	ϕ clock stop Enables or disables ϕ clock output.							
MSTCRL—Module Standby Control Register L					H'EE01D	System control		
Bit	7	6	5	4	3	2	1	0
	MSTPL7	—	MSTPL5	MSTPL4	MSTPL3	MSTPL2	—	MSTPL0
Initial value	0	0	0	0	0	0	0	0
Read/Write	R/W	R/W	R/W	R/W	R/W	R/W	R/W	R/W
	Reserved bits		Module standby L7, L5 to L2, L0 Selection bits for placing modules in standby state.					

ADRCR—Address Control Register				H'EE01E		Bus controller		
Bit	7	6	5	4	3	2	1	0
	—	—	—	—	—	—	—	ADRCTL
Initial value	1	1	1	1	1	1	1	1
Read/Write	—	—	—	—	—	—	—	R/W
				Reserved bits			Address control	
				Selects address update mode 1 or address update mode 2.				
		ADRCTL		Description				
		0		Address update mode 2 is selected				
		1		Address update mode 1 is selected (Initial value)				
Note: * This register is used only in the flash memory R version and mask ROM version.								
CSCR—Chip Select Control Register				H'EE01F		Bus controller		
Bit	7	6	5	4	3	2	1	0
	CS7E	CS6E	CS5E	CS4E	—	—	—	—
Initial value	0	0	0	0	1	1	1	1
Read/Write	R/W	R/W	R/W	R/W	—	—	—	—
				Chip select 7 to 4 enable				
		Bit n		Description				
		CSnE						
		0		Output of chip select signal CSn is disabled (Initial value)				
		1		Output of chip select signal CSn is enabled				
(n = 7 to 4)								

ABWCR—Bus Width Control Register				H'EE020				Bus controller													
		Bit	7	6	5	4	3	2	1	0											
			ABW7	ABW6	ABW5	ABW4	ABW3	ABW2	ABW1	ABW0											
Modes 1, 3, 5, 6, 7	Initial value		1	1	1	1	1	1	1	1											
Modes 2, 4	Initial value		0	0	0	0	0	0	0	0											
	Read/Write		R/W	R/W	R/W	R/W	R/W	R/W	R/W	R/W											
Area 7 to 0 bus width control																					
			Bits 7 to 0	Bus Width of Access Area																	
			ABW7 to ABW0																		
			0										Areas 7 to 0 are 16-bit access areas								
			1										Areas 7 to 0 are 8-bit access areas								
ASTCR—Access State Control Register				H'EE021				Bus controller													
		Bit	7	6	5	4	3	2	1	0											
			AST7	AST6	AST5	AST4	AST3	AST2	AST1	AST0											
Initial value			1	1	1	1	1	1	1	1											
Read/Write			R/W	R/W	R/W	R/W	R/W	R/W	R/W	R/W											
Area 7 to 0 access state control																					
			Bits 7 to 0	Number of States in Access Area																	
			AST7 to AST0																		
			0										Areas 7 to 0 are two-state access areas								
			1										Areas 7 to 0 are three-state access areas								

WCRH—Wait Control Register H						H'EE022	Bus controller											
Bit	7	6	5	4	3	2	1	0										
	W71	W70	W61	W60	W51	W50	W41	W40										
Initial value	1	1	1	1	1	1	1	1										
Read/Write	R/W	R/W	R/W	R/W	R/W	R/W	R/W	R/W										
						Area 4 wait control 1 and 0												
						<table border="1"> <tr> <td rowspan="2">0</td> <td>0</td> <td>No program wait is inserted</td> </tr> <tr> <td>1</td> <td>1 program wait state is inserted</td> </tr> <tr> <td rowspan="2">1</td> <td>0</td> <td>2 program wait states are inserted</td> </tr> <tr> <td>1</td> <td>3 program wait states are inserted</td> </tr> </table>			0	0	No program wait is inserted	1	1 program wait state is inserted	1	0	2 program wait states are inserted	1	3 program wait states are inserted
0	0	No program wait is inserted																
	1	1 program wait state is inserted																
1	0	2 program wait states are inserted																
	1	3 program wait states are inserted																
						Area 5 wait control 1 and 0												
						<table border="1"> <tr> <td rowspan="2">0</td> <td>0</td> <td>No program wait is inserted</td> </tr> <tr> <td>1</td> <td>1 program wait state is inserted</td> </tr> <tr> <td rowspan="2">1</td> <td>0</td> <td>2 program wait states are inserted</td> </tr> <tr> <td>1</td> <td>3 program wait states are inserted</td> </tr> </table>			0	0	No program wait is inserted	1	1 program wait state is inserted	1	0	2 program wait states are inserted	1	3 program wait states are inserted
0	0	No program wait is inserted																
	1	1 program wait state is inserted																
1	0	2 program wait states are inserted																
	1	3 program wait states are inserted																
						Area 6 wait control 1 and 0												
						<table border="1"> <tr> <td rowspan="2">0</td> <td>0</td> <td>No program wait is inserted</td> </tr> <tr> <td>1</td> <td>1 program wait state is inserted</td> </tr> <tr> <td rowspan="2">1</td> <td>0</td> <td>2 program wait states are inserted</td> </tr> <tr> <td>1</td> <td>3 program wait states are inserted</td> </tr> </table>			0	0	No program wait is inserted	1	1 program wait state is inserted	1	0	2 program wait states are inserted	1	3 program wait states are inserted
0	0	No program wait is inserted																
	1	1 program wait state is inserted																
1	0	2 program wait states are inserted																
	1	3 program wait states are inserted																
						Area 7 wait control 1 and 0												
						<table border="1"> <tr> <td rowspan="2">0</td> <td>0</td> <td>No program wait is inserted</td> </tr> <tr> <td>1</td> <td>1 program wait state is inserted</td> </tr> <tr> <td rowspan="2">1</td> <td>0</td> <td>2 program wait states are inserted</td> </tr> <tr> <td>1</td> <td>3 program wait states are inserted</td> </tr> </table>			0	0	No program wait is inserted	1	1 program wait state is inserted	1	0	2 program wait states are inserted	1	3 program wait states are inserted
0	0	No program wait is inserted																
	1	1 program wait state is inserted																
1	0	2 program wait states are inserted																
	1	3 program wait states are inserted																

WCRL—Wait Control Register L					H'EE023	Bus controller												
Bit	7	6	5	4	3	2	1	0										
	W31	W30	W21	W20	W11	W10	W01	W00										
Initial value	1	1	1	1	1	1	1	1										
Read/Write	R/W	R/W	R/W	R/W	R/W	R/W	R/W	R/W										
						Area 0 wait control 1 and 0												
						<table border="1"> <tbody> <tr> <td rowspan="2">0</td> <td>0</td> <td>No program wait is inserted</td> </tr> <tr> <td>1</td> <td>1 program wait state is inserted</td> </tr> <tr> <td rowspan="2">1</td> <td>0</td> <td>2 program wait states are inserted</td> </tr> <tr> <td>1</td> <td>3 program wait states are inserted</td> </tr> </tbody> </table>			0	0	No program wait is inserted	1	1 program wait state is inserted	1	0	2 program wait states are inserted	1	3 program wait states are inserted
0	0	No program wait is inserted																
	1	1 program wait state is inserted																
1	0	2 program wait states are inserted																
	1	3 program wait states are inserted																
						Area 1 wait control 1 and 0												
						<table border="1"> <tbody> <tr> <td rowspan="2">0</td> <td>0</td> <td>No program wait is inserted</td> </tr> <tr> <td>1</td> <td>1 program wait state is inserted</td> </tr> <tr> <td rowspan="2">1</td> <td>0</td> <td>2 program wait states are inserted</td> </tr> <tr> <td>1</td> <td>3 program wait states are inserted</td> </tr> </tbody> </table>			0	0	No program wait is inserted	1	1 program wait state is inserted	1	0	2 program wait states are inserted	1	3 program wait states are inserted
0	0	No program wait is inserted																
	1	1 program wait state is inserted																
1	0	2 program wait states are inserted																
	1	3 program wait states are inserted																
						Area 2 wait control 1 and 0												
						<table border="1"> <tbody> <tr> <td rowspan="2">0</td> <td>0</td> <td>No program wait is inserted</td> </tr> <tr> <td>1</td> <td>1 program wait state is inserted</td> </tr> <tr> <td rowspan="2">1</td> <td>0</td> <td>2 program wait states are inserted</td> </tr> <tr> <td>1</td> <td>3 program wait states are inserted</td> </tr> </tbody> </table>			0	0	No program wait is inserted	1	1 program wait state is inserted	1	0	2 program wait states are inserted	1	3 program wait states are inserted
0	0	No program wait is inserted																
	1	1 program wait state is inserted																
1	0	2 program wait states are inserted																
	1	3 program wait states are inserted																
						Area 3 wait control 1 and 0												
						<table border="1"> <tbody> <tr> <td rowspan="2">0</td> <td>0</td> <td>No program wait is inserted</td> </tr> <tr> <td>1</td> <td>1 program wait state is inserted</td> </tr> <tr> <td rowspan="2">1</td> <td>0</td> <td>2 program wait states are inserted</td> </tr> <tr> <td>1</td> <td>3 program wait states are inserted</td> </tr> </tbody> </table>			0	0	No program wait is inserted	1	1 program wait state is inserted	1	0	2 program wait states are inserted	1	3 program wait states are inserted
0	0	No program wait is inserted																
	1	1 program wait state is inserted																
1	0	2 program wait states are inserted																
	1	3 program wait states are inserted																

BCR—Bus Control Register						H'EE024	Bus controller							
Bit	7	6	5	4	3	2	1	0						
	ICIS1	ICIS0	BROME	BRSTS1	BRSTS0	—	RDEA	WAITE						
Initial value	1	1	0	0	0	1	1	0						
Read/Write	R/W	R/W	R/W	R/W	R/W	—	R/W	R/W						
								<table border="1"> <tr> <td colspan="2">Wait pin enable</td> </tr> <tr> <td>0</td> <td>WAIT pin wait input is disabled</td> </tr> <tr> <td>1</td> <td>WAIT pin wait input is enabled</td> </tr> </table>	Wait pin enable		0	WAIT pin wait input is disabled	1	WAIT pin wait input is enabled
Wait pin enable														
0	WAIT pin wait input is disabled													
1	WAIT pin wait input is enabled													
								<table border="1"> <tr> <td colspan="2">Area division unit select</td> </tr> <tr> <td>0</td> <td>Area divisions are as follows: Area 0: 2 MB Area 4: 1.93 MB Area 1: 2 MB Area 5: 4 kB Area 2: 8 MB Area 6: 23.75 kB Area 3: 2 MB Area 7: 22 B</td> </tr> <tr> <td>1</td> <td>Areas 0 to 7 are the same size (2 MB)</td> </tr> </table>	Area division unit select		0	Area divisions are as follows: Area 0: 2 MB Area 4: 1.93 MB Area 1: 2 MB Area 5: 4 kB Area 2: 8 MB Area 6: 23.75 kB Area 3: 2 MB Area 7: 22 B	1	Areas 0 to 7 are the same size (2 MB)
Area division unit select														
0	Area divisions are as follows: Area 0: 2 MB Area 4: 1.93 MB Area 1: 2 MB Area 5: 4 kB Area 2: 8 MB Area 6: 23.75 kB Area 3: 2 MB Area 7: 22 B													
1	Areas 0 to 7 are the same size (2 MB)													
								<table border="1"> <tr> <td colspan="2">Burst cycle select 0</td> </tr> <tr> <td>0</td> <td>Max. 4 words in burst access</td> </tr> <tr> <td>1</td> <td>Max. 8 words in burst access</td> </tr> </table>	Burst cycle select 0		0	Max. 4 words in burst access	1	Max. 8 words in burst access
Burst cycle select 0														
0	Max. 4 words in burst access													
1	Max. 8 words in burst access													
								<table border="1"> <tr> <td colspan="2">Burst cycle select 1</td> </tr> <tr> <td>0</td> <td>Burst access cycle comprises 2 states</td> </tr> <tr> <td>1</td> <td>Burst access cycle comprises 3 states</td> </tr> </table>	Burst cycle select 1		0	Burst access cycle comprises 2 states	1	Burst access cycle comprises 3 states
Burst cycle select 1														
0	Burst access cycle comprises 2 states													
1	Burst access cycle comprises 3 states													
								<table border="1"> <tr> <td colspan="2">Burst ROM enable</td> </tr> <tr> <td>0</td> <td>Area 0 is a basic bus interface area</td> </tr> <tr> <td>1</td> <td>Area 0 is a burst ROM interface area</td> </tr> </table>	Burst ROM enable		0	Area 0 is a basic bus interface area	1	Area 0 is a burst ROM interface area
Burst ROM enable														
0	Area 0 is a basic bus interface area													
1	Area 0 is a burst ROM interface area													
								<table border="1"> <tr> <td colspan="2">Idle cycle insertion 0</td> </tr> <tr> <td>0</td> <td>No idle cycle is inserted in case of consecutive external read and write cycles</td> </tr> <tr> <td>1</td> <td>Idle cycle is inserted in case of consecutive external read and write cycles</td> </tr> </table>	Idle cycle insertion 0		0	No idle cycle is inserted in case of consecutive external read and write cycles	1	Idle cycle is inserted in case of consecutive external read and write cycles
Idle cycle insertion 0														
0	No idle cycle is inserted in case of consecutive external read and write cycles													
1	Idle cycle is inserted in case of consecutive external read and write cycles													
								<table border="1"> <tr> <td colspan="2">Idle cycle insertion 1</td> </tr> <tr> <td>0</td> <td>No idle cycle is inserted in case of consecutive external read cycles for different areas</td> </tr> <tr> <td>1</td> <td>Idle cycle is inserted in case of consecutive external read cycles for different areas</td> </tr> </table>	Idle cycle insertion 1		0	No idle cycle is inserted in case of consecutive external read cycles for different areas	1	Idle cycle is inserted in case of consecutive external read cycles for different areas
Idle cycle insertion 1														
0	No idle cycle is inserted in case of consecutive external read cycles for different areas													
1	Idle cycle is inserted in case of consecutive external read cycles for different areas													

DRCRA—DRAM Control Register A					H'EE026			DRAM interface
Bit	7	6	5	4	3	2	1	0
	DRAS2	DRAS1	DRAS0	—	BE	RDM	SRFMD	RFSHE
Initial value	0	0	0	1	0	0	0	0
Read/Write	R/W	R/W	R/W	—	R/W	R/W	R/W	R/W

Refresh pin enable

0	RFSH pin refresh signal output is disabled
1	RFSH pin refresh signal output is enabled

Self-refresh mode

0	DRAM self-refreshing is disabled in software standby mode
1	DRAM self-refreshing is enabled in software standby mode

RAS down mode

0	DRAM interface: RAS up mode selected
1	DRAM interface: RAS down mode selected

Burst access enable

0	Burst disabled (always full access)
1	DRAM space access performed in fast page mode

DRAM area select

DRAS2	DRAS1	DRAS0	Area 5	Area 4	Area 3	Area 2
0	0	0	Normal	Normal	Normal	Normal
		1	Normal	Normal	Normal	DRAM space (\overline{CS}_2)
	1	0	Normal	Normal	DRAM space (\overline{CS}_3)	DRAM space (\overline{CS}_2)
		1	Normal	Normal	DRAM space (\overline{CS}_2)*	
1	0	0	Normal	DRAM space (\overline{CS}_4)	DRAM space (\overline{CS}_3)	DRAM space (\overline{CS}_2)
		1	DRAM space (\overline{CS}_5)	DRAM space (\overline{CS}_4)	DRAM space (\overline{CS}_3)	DRAM space (\overline{CS}_2)
	1	0	DRAM space (\overline{CS}_4)*		DRAM space (\overline{CS}_2)*	
		1	DRAM space (\overline{CS}_2)*			

Note: * A single \overline{CS}_n pin serves as a common \overline{RAS} output pin for a number of areas. Unused \overline{CS}_n pins can be used as input/output ports.

DRCRB—DRAM Control Register B	H'EE027	DRAM interface
--------------------------------------	----------------	-----------------------

Bit	7	6	5	4	3	2	1	0
	MXC1	MXC0	CSEL	RCYCE	—	TPC	RCW	RLW
Initial value	0	0	0	0	1	0	0	0
Read/Write	R/W	R/W	R/W	R/W	—	R/W	R/W	R/W

Refresh cycle wait control	
0	Wait state (T_{RW}) insertion is disabled
1	1 wait state (T_{RW}) is inserted

RAS-CAS wait	
0	Wait state (T_{rw}) insertion is disabled
1	1 wait state (T_{rw}) is inserted

TP cycle control	
0	1-state precharge cycle is inserted
1	2-state precharge cycle is inserted

Refresh cycle enable	
0	Refresh cycles are disabled
1	DRAM refresh cycles are enabled

CAS output pin select	
0	PB4 and PB5 selected as \overline{UCAS} and \overline{LCAS} output pins
1	HWR and LWR selected as \overline{UCAS} and \overline{LCAS} output pins

Multiplex control 1 and 0

MXC1	MXC0	Description		
0	0	Column address: 8 bits Compared address: Modes 1, 2 8-bit access space A_{19} to A_8 16-bit access space A_{19} to A_9 Modes 3, 4, 5 8-bit access space A_{23} to A_8 16-bit access space A_{23} to A_9		
		1	Column address: 9 bits Compared address: Modes 1, 2 8-bit access space A_{19} to A_9 16-bit access space A_{19} to A_{10} Modes 3, 4, 5 8-bit access space A_{23} to A_9 16-bit access space A_{23} to A_{10}	
			0	Column address: 10 bits Compared address: Modes 1, 2 8-bit access space A_{19} to A_{10} 16-bit access space A_{19} to A_{11} Modes 3, 4, 5 8-bit access space A_{23} to A_{10} 16-bit access space A_{23} to A_{11}
				1

RTMCSR—Refresh Timer Control/Status Register	H'EE028	DRAM interface
---	----------------	-----------------------

Bit	7	6	5	4	3	2	1	0
	CMF	CMIE	CKS2	CKS1	CKS0	—	—	—
Initial value	0	0	0	0	0	1	1	1
Read/Write	R/(W)*	R/W	R/W	R/W	R/W	—	—	—

Refresh counter clock select

CKS2	CKS1	CKS0	Description
0	0	0	Count operation halted
		1	$\phi/2$ used as counter clock
	1	0	$\phi/8$ used as counter clock
		1	$\phi/32$ used as counter clock
1	0	0	$\phi/128$ used as counter clock
		1	$\phi/512$ used as counter clock
	1	0	$\phi/2048$ used as counter clock
		1	$\phi/4096$ used as counter clock

Compare match interrupt enable

0	The CMI interrupt requested by the CMF flag is disabled
1	The CMI interrupt requested by the CMF flag is enabled

Compare match flag

0	[Clearing conditions] <ul style="list-style-type: none"> • Cleared by a reset and in standby mode • Cleared by reading CMF when CMF = 1, then writing 0 in CMF
1	[Setting condition] <p style="margin-left: 20px;">When RTCNT = RTCOR</p>

Note: * Only 0 can be written to clear the flag.

RTCNT—Refresh Timer Counter				H'EE029	DRAM interface			
Bit	7	6	5	4	3	2	1	0
	<input type="checkbox"/>	<input type="checkbox"/>	<input type="checkbox"/>	<input type="checkbox"/>	<input type="checkbox"/>	<input type="checkbox"/>	<input type="checkbox"/>	<input type="checkbox"/>
Initial value	0	0	0	0	0	0	0	0
Read/Write	R/W	R/W	R/W	R/W	R/W	R/W	R/W	R/W
 Incremented by internal clock selected by bits CKS2 to CKS0 in RTMCSR								
RTCOR—Refresh Time Constant Register				H'EE02A	DRAM interface			
Bit	7	6	5	4	3	2	1	0
	<input type="checkbox"/>	<input type="checkbox"/>	<input type="checkbox"/>	<input type="checkbox"/>	<input type="checkbox"/>	<input type="checkbox"/>	<input type="checkbox"/>	<input type="checkbox"/>
Initial value	1	1	1	1	1	1	1	1
Read/Write	R/W	R/W	R/W	R/W	R/W	R/W	R/W	R/W
 RTCNT compare match period								
Note: Only byte access can be used on this register.								

FLMCR1—Flash Memory Control Register 1				H'EE030				Flash Memory						
Bit	7	6	5	4	3	2	1	0						
	FWE	SWE	ESU	PSU	EV	PV	E	P						
Modes 1 to 4, and 6	Initial value	0	0	0	0	0	0	0						
	Read/Write	R	R	R	R	R	R	R						
Modes 5 and 7	Initial value	1/0	0	0	0	0	0	0						
	Read/Write	R	R/W	R/W	R/W	R/W	R/W	R/W						
<table border="1"> <thead> <tr> <th colspan="2">Program mode</th> </tr> </thead> <tbody> <tr> <td>0</td> <td>Program mode cleared (Initial value)</td> </tr> <tr> <td>1</td> <td>Transition to program mode [Setting condition] When FWE = 1, SWE = 1, and PSU = 1</td> </tr> </tbody> </table>									Program mode		0	Program mode cleared (Initial value)	1	Transition to program mode [Setting condition] When FWE = 1, SWE = 1, and PSU = 1
Program mode														
0	Program mode cleared (Initial value)													
1	Transition to program mode [Setting condition] When FWE = 1, SWE = 1, and PSU = 1													
<table border="1"> <thead> <tr> <th colspan="2">Erase mode</th> </tr> </thead> <tbody> <tr> <td>0</td> <td>Erase mode cleared (Initial value)</td> </tr> <tr> <td>1</td> <td>Transition to erase mode [Setting condition] When FWE = 1, SWE = 1, and ESU = 1</td> </tr> </tbody> </table>									Erase mode		0	Erase mode cleared (Initial value)	1	Transition to erase mode [Setting condition] When FWE = 1, SWE = 1, and ESU = 1
Erase mode														
0	Erase mode cleared (Initial value)													
1	Transition to erase mode [Setting condition] When FWE = 1, SWE = 1, and ESU = 1													
<table border="1"> <thead> <tr> <th colspan="2">Program-verify mode</th> </tr> </thead> <tbody> <tr> <td>0</td> <td>Program-verify mode cleared (Initial value)</td> </tr> <tr> <td>1</td> <td>Transition to program-verify mode [Setting condition] When FWE = 1 and SWE = 1</td> </tr> </tbody> </table>									Program-verify mode		0	Program-verify mode cleared (Initial value)	1	Transition to program-verify mode [Setting condition] When FWE = 1 and SWE = 1
Program-verify mode														
0	Program-verify mode cleared (Initial value)													
1	Transition to program-verify mode [Setting condition] When FWE = 1 and SWE = 1													
<table border="1"> <thead> <tr> <th colspan="2">Erase-verify mode</th> </tr> </thead> <tbody> <tr> <td>0</td> <td>Erase-verify mode cleared (Initial value)</td> </tr> <tr> <td>1</td> <td>Transition to erase-verify mode [Setting condition] When FWE = 1 and SWE = 1</td> </tr> </tbody> </table>									Erase-verify mode		0	Erase-verify mode cleared (Initial value)	1	Transition to erase-verify mode [Setting condition] When FWE = 1 and SWE = 1
Erase-verify mode														
0	Erase-verify mode cleared (Initial value)													
1	Transition to erase-verify mode [Setting condition] When FWE = 1 and SWE = 1													
<table border="1"> <thead> <tr> <th colspan="2">Program setup</th> </tr> </thead> <tbody> <tr> <td>0</td> <td>Program setup cleared (Initial value)</td> </tr> <tr> <td>1</td> <td>Program setup [Setting condition] When FWE = 1 and SWE = 1</td> </tr> </tbody> </table>									Program setup		0	Program setup cleared (Initial value)	1	Program setup [Setting condition] When FWE = 1 and SWE = 1
Program setup														
0	Program setup cleared (Initial value)													
1	Program setup [Setting condition] When FWE = 1 and SWE = 1													
<table border="1"> <thead> <tr> <th colspan="2">Erase setup bit</th> </tr> </thead> <tbody> <tr> <td>0</td> <td>Erase setup cleared (Initial value)</td> </tr> <tr> <td>1</td> <td>Erase setup [Setting condition] When FWE = 1 and SWE = 1</td> </tr> </tbody> </table>									Erase setup bit		0	Erase setup cleared (Initial value)	1	Erase setup [Setting condition] When FWE = 1 and SWE = 1
Erase setup bit														
0	Erase setup cleared (Initial value)													
1	Erase setup [Setting condition] When FWE = 1 and SWE = 1													
<table border="1"> <thead> <tr> <th colspan="2">Software write enable bit</th> </tr> </thead> <tbody> <tr> <td>0</td> <td>Write/erase disabled (Initial value)</td> </tr> <tr> <td>1</td> <td>Write/erase enabled [Setting condition] When FWE = 1</td> </tr> </tbody> </table>									Software write enable bit		0	Write/erase disabled (Initial value)	1	Write/erase enabled [Setting condition] When FWE = 1
Software write enable bit														
0	Write/erase disabled (Initial value)													
1	Write/erase enabled [Setting condition] When FWE = 1													
<table border="1"> <thead> <tr> <th colspan="2">Flash write enable bit</th> </tr> </thead> <tbody> <tr> <td>0</td> <td>When a low level is input to the FWE pin (hardware protection state)</td> </tr> <tr> <td>1</td> <td>When a high level is input to the FWE pin</td> </tr> </tbody> </table>									Flash write enable bit		0	When a low level is input to the FWE pin (hardware protection state)	1	When a high level is input to the FWE pin
Flash write enable bit														
0	When a low level is input to the FWE pin (hardware protection state)													
1	When a high level is input to the FWE pin													
<p>Note: This register is used only in the flash memory and flash memory R versions. Reading the corresponding address in a mask ROM version will always return 1s, and writes to this address are disabled. Fix the FWE pin low in mode 6.</p>														

FLMCR (FLMCR2)—Flash Memory Control Register 2	H'EE031	Flash Memory
---	----------------	---------------------

Bit	7	6	5	4	3	2	1	0
	FLER	—	—	—	—	—	—	—
Initial value	0	0	0	0	0	0	0	0
Read/Write	R	—	—	—	—	—	—	—

	Flash memory error				Reserved bits			

Note: Writes to FLMCR2 are prohibited.

EBR (EBR1)—Erase Block Register			H'EE032			Flash Memory			
Bit		7	6	5	4	3	2	1	0
		EB7	EB6	EB5	EB4	EB3	EB2	EB1	EB0
Modes 1 to 4, and 6	Initial value	0	0	0	0	0	0	0	0
	Read/Write	R	R	R	R	R	R	R	R
Modes 5 and 7	Initial value	0	0	0	0	0	0	0	0
	Read/Write	R	R/W	R/W	R/W	R/W	R/W	R/W	R/W

Block 7 to 0	
0	Block EB7 to EB0 is not selected (Initial value)
1	Block EB7 to EB0 is selected

Note: When not erasing, clear EBR to H'00.
Writes are invalid.
A value of 1 cannot be set in this register in mode 6.

EBR (EBR2)—Erase Block Register 2		H'EE033			Flash Memory				
Bit		7	6	5	4	3	2	1	0
		—	—	EB13	EB12	EB11	EB10	EB9	EB8
Modes 1 to 4, and 6	Initial value	0	0	0	0	0	0	0	0
	Read/Write	R	R	R	R	R	R	R	R
Modes 5 and 7	Initial value	0	0	0	0	0	0	0	0
	Read/Write	R/W	R/W	R/W	R/W	R/W	R/W	R/W	R/W

Block 13 to 8	
0	Block EB13 to EB8 is not selected (Initial value)
1	Block EB13 to EB8 is selected

Note: When not erasing, clear EBR to H'00.
A value of 1 cannot be set in this register in mode 6.

P2PCR—Port 2 Input Pull-Up Control Register					H'EE03C	Port 2						
Bit	7	6	5	4	3	2	1	0				
	P27PCR	P26PCR	P25PCR	P24PCR	P23PCR	P22PCR	P21PCR	P20PCR				
Initial value	0	0	0	0	0	0	0	0				
Read/Write	R/W	R/W	R/W	R/W	R/W	R/W	R/W	R/W				
Port 2 input pull-up control 7 to 0 <table border="1" style="margin: 10px auto;"> <tr> <td>0</td> <td>Input pull-up transistor is off</td> </tr> <tr> <td>1</td> <td>Input pull-up transistor is on</td> </tr> </table>									0	Input pull-up transistor is off	1	Input pull-up transistor is on
0	Input pull-up transistor is off											
1	Input pull-up transistor is on											
Note: Valid when the corresponding P2DDR bit is cleared to 0 (designating generic input).												

P4PCR—Port 4 Input Pull-Up Control Register					H'EE03E	Port 4						
Bit	7	6	5	4	3	2	1	0				
	P47PCR	P46PCR	P45PCR	P44PCR	P43PCR	P42PCR	P41PCR	P40PCR				
Initial value	0	0	0	0	0	0	0	0				
Read/Write	R/W	R/W	R/W	R/W	R/W	R/W	R/W	R/W				
Port 4 input pull-up control 7 to 0 <table border="1" style="margin-left: auto; margin-right: auto;"> <tr> <td>0</td> <td>Input pull-up transistor is off</td> </tr> <tr> <td>1</td> <td>Input pull-up transistor is on</td> </tr> </table>									0	Input pull-up transistor is off	1	Input pull-up transistor is on
0	Input pull-up transistor is off											
1	Input pull-up transistor is on											
Note: Valid when the corresponding P4DDR bit is cleared to 0 (designating generic input).												
P5PCR—Port 5 Input Pull-Up Control Register					H'EE03F	Port 5						
Bit	7	6	5	4	3	2	1	0				
	—	—	—	—	P53PCR	P52PCR	P51PCR	P50PCR				
Initial value	1	1	1	1	0	0	0	0				
Read/Write	—	—	—	—	R/W	R/W	R/W	R/W				
Port 5 input pull-up control 3 to 0 <table border="1" style="margin-left: auto; margin-right: auto;"> <tr> <td>0</td> <td>Input pull-up transistor is off</td> </tr> <tr> <td>1</td> <td>Input pull-up transistor is on</td> </tr> </table>									0	Input pull-up transistor is off	1	Input pull-up transistor is on
0	Input pull-up transistor is off											
1	Input pull-up transistor is on											
Note: Valid when the corresponding P5DDR bit is cleared to 0 (designating generic input).												

RAM Control Register		RAMCR				H'EE077	Flash Memory		
Bit		7	6	5	4	3	2	1	0
		—	—	—	—	RAMS	RAM2	RAM1	RAM0
Modes 1 to 4	Initial value	1	1	1	1	0	0	0	0
	R/W	—	—	—	—	R	R	R	—
Modes 5 to 7	Initial value	1	1	1	1	0	0	0	0
	R/W	—	—	—	—	R/W*	R/W*	R/W*	R/W*
Reserved bits									
RAM select, RAM2 to RAM0									
Bit 3	Bit 2	Bit 1	Bit 0	RAM Area		RAM Emulation Status			
RAMS	RAM2	RAM1	RAM0						
0	0/1	0/1	0/1	H'FFE000 to H'FFFEFFF		Emulation			
1	0	0	0	H'000000 to H'000FFF		Mapping RAM			
			1	H'001000 to H'001FFF					
		1	0	H'002000 to H'002FFF					
			1	H'003000 to H'003FFF					
	1	0	0	H'004000 to H'004FFF					
			1	H'005000 to H'005FFF					
		1	0	H'006000 to H'006FFF					
			1	H'007000 to H'007FFF					

Note: * In mode 6 (single-chip normal mode), flash memory emulation by RAM is not supported; these bits can be modified, but must not be set to 1.

Note: This register is used only in the flash memory and flash memory R versions. Reading the corresponding address in a mask ROM version will always return 1s, and writes to this address are disabled.

ETCR0A H/L—Execute Transfer Count Register 0A H/L										H'FFF24 H'FFF25				DMAC0																																																																																																																																																																																																																																																																																																																																																																																							
<ul style="list-style-type: none"> Short address mode <ul style="list-style-type: none"> I/O mode and idle mode <table border="0" style="width: 100%; border-collapse: collapse;"> <tr> <td style="text-align: center;">Bit</td> <td style="text-align: center;">15</td><td style="text-align: center;">14</td><td style="text-align: center;">13</td><td style="text-align: center;">12</td><td style="text-align: center;">11</td><td style="text-align: center;">10</td><td style="text-align: center;">9</td><td style="text-align: center;">8</td><td style="text-align: center;">7</td><td style="text-align: center;">6</td><td style="text-align: center;">5</td><td style="text-align: center;">4</td><td style="text-align: center;">3</td><td style="text-align: center;">2</td><td style="text-align: center;">1</td><td style="text-align: center;">0</td> </tr> <tr> <td></td> <td style="border: 1px solid black; width: 20px; height: 20px;"></td><td style="border: 1px solid black; width: 20px; height: 20px;"></td><td style="border: 1px solid black; width: 20px; height: 20px;"></td><td style="border: 1px solid black; width: 20px; height: 20px;"></td><td style="border: 1px solid black; width: 20px; height: 20px;"></td><td style="border: 1px solid black; width: 20px; height: 20px;"></td><td style="border: 1px solid black; width: 20px; height: 20px;"></td><td style="border: 1px solid black; width: 20px; height: 20px;"></td><td style="border: 1px solid black; width: 20px; height: 20px;"></td><td style="border: 1px solid black; width: 20px; height: 20px;"></td><td style="border: 1px solid black; width: 20px; height: 20px;"></td><td style="border: 1px solid black; width: 20px; height: 20px;"></td><td style="border: 1px solid black; width: 20px; height: 20px;"></td><td style="border: 1px solid black; width: 20px; height: 20px;"></td><td style="border: 1px solid black; width: 20px; height: 20px;"></td><td style="border: 1px solid black; width: 20px; height: 20px;"></td> </tr> <tr> <td>Initial value</td> <td colspan="16" style="text-align: center;">Undetermined</td> </tr> <tr> <td>Read/Write</td> <td style="text-align: center;">R/W</td><td style="text-align: center;">R/W</td><td style="text-align: center;">R/W</td><td style="text-align: center;">R/W</td><td style="text-align: center;">R/W</td><td style="text-align: center;">R/W</td><td style="text-align: center;">R/W</td><td style="text-align: center;">R/W</td><td style="text-align: center;">R/W</td><td style="text-align: center;">R/W</td><td style="text-align: center;">R/W</td><td style="text-align: center;">R/W</td><td style="text-align: center;">R/W</td><td style="text-align: center;">R/W</td><td style="text-align: center;">R/W</td><td style="text-align: center;">R/W</td> </tr> <tr> <td></td> <td colspan="16" style="text-align: center;"> <div style="border-top: 1px solid black; width: 100%; margin: 0 auto;"></div> Transfer counter </td> </tr> </table> Repeat mode <table border="0" style="width: 100%; border-collapse: collapse;"> <tr> <td style="text-align: center;">Bit</td> <td style="text-align: center;">7</td><td style="text-align: center;">6</td><td style="text-align: center;">5</td><td style="text-align: center;">4</td><td style="text-align: center;">3</td><td style="text-align: center;">2</td><td style="text-align: center;">1</td><td style="text-align: center;">0</td> <td style="text-align: center;">7</td><td style="text-align: center;">6</td><td style="text-align: center;">5</td><td style="text-align: center;">4</td><td style="text-align: center;">3</td><td style="text-align: center;">2</td><td style="text-align: center;">1</td><td style="text-align: center;">0</td> </tr> <tr> <td></td> <td style="border: 1px solid black; width: 20px; height: 20px;"></td><td style="border: 1px solid black; width: 20px; height: 20px;"></td><td style="border: 1px solid black; width: 20px; height: 20px;"></td><td style="border: 1px solid black; width: 20px; height: 20px;"></td><td style="border: 1px solid black; width: 20px; height: 20px;"></td><td style="border: 1px solid black; width: 20px; height: 20px;"></td><td style="border: 1px solid black; width: 20px; height: 20px;"></td><td style="border: 1px solid black; width: 20px; height: 20px;"></td> <td style="border: 1px solid black; width: 20px; height: 20px;"></td><td style="border: 1px solid black; width: 20px; height: 20px;"></td><td style="border: 1px solid black; width: 20px; height: 20px;"></td><td style="border: 1px solid black; width: 20px; height: 20px;"></td><td style="border: 1px solid black; width: 20px; height: 20px;"></td><td style="border: 1px solid black; width: 20px; height: 20px;"></td><td style="border: 1px solid black; width: 20px; height: 20px;"></td><td style="border: 1px solid black; width: 20px; height: 20px;"></td> </tr> <tr> <td>Initial value</td> <td colspan="8" style="text-align: center;">Undetermined</td> <td colspan="8" style="text-align: center;">Undetermined</td> </tr> <tr> <td>Read/Write</td> <td style="text-align: center;">R/W</td><td style="text-align: center;">R/W</td><td style="text-align: center;">R/W</td><td style="text-align: center;">R/W</td><td style="text-align: center;">R/W</td><td style="text-align: center;">R/W</td><td style="text-align: center;">R/W</td><td style="text-align: center;">R/W</td> <td style="text-align: center;">R/W</td><td style="text-align: center;">R/W</td><td style="text-align: center;">R/W</td><td style="text-align: center;">R/W</td><td style="text-align: center;">R/W</td><td style="text-align: center;">R/W</td><td style="text-align: center;">R/W</td><td style="text-align: center;">R/W</td> </tr> <tr> <td></td> <td colspan="8" style="text-align: center;"> <div style="border-top: 1px solid black; width: 100%; margin: 0 auto;"></div> ETCR0AH </td> <td colspan="8" style="text-align: center;"> <div style="border-top: 1px solid black; width: 100%; margin: 0 auto;"></div> ETCR0AL </td> </tr> <tr> <td></td> <td colspan="8" style="text-align: center;"> <div style="border-top: 1px solid black; width: 100%; margin: 0 auto;"></div> Transfer counter </td> <td colspan="8" style="text-align: center;"> <div style="border-top: 1px solid black; width: 100%; margin: 0 auto;"></div> Initial count </td> </tr> </table> Full address mode <ul style="list-style-type: none"> Normal mode <table border="0" style="width: 100%; border-collapse: collapse;"> <tr> <td style="text-align: center;">Bit</td> <td style="text-align: center;">15</td><td style="text-align: center;">14</td><td style="text-align: center;">13</td><td style="text-align: center;">12</td><td style="text-align: center;">11</td><td style="text-align: center;">10</td><td style="text-align: center;">9</td><td style="text-align: center;">8</td><td style="text-align: center;">7</td><td style="text-align: center;">6</td><td style="text-align: center;">5</td><td style="text-align: center;">4</td><td style="text-align: center;">3</td><td style="text-align: center;">2</td><td style="text-align: center;">1</td><td style="text-align: center;">0</td> </tr> <tr> <td></td> <td style="border: 1px solid black; width: 20px; height: 20px;"></td><td style="border: 1px solid black; width: 20px; height: 20px;"></td><td style="border: 1px solid black; width: 20px; height: 20px;"></td><td style="border: 1px solid black; width: 20px; height: 20px;"></td><td style="border: 1px solid black; width: 20px; height: 20px;"></td><td style="border: 1px solid black; width: 20px; height: 20px;"></td><td style="border: 1px solid black; width: 20px; height: 20px;"></td><td style="border: 1px solid black; width: 20px; height: 20px;"></td><td style="border: 1px solid black; width: 20px; height: 20px;"></td><td style="border: 1px solid black; width: 20px; height: 20px;"></td><td style="border: 1px solid black; width: 20px; height: 20px;"></td><td style="border: 1px solid black; width: 20px; height: 20px;"></td><td style="border: 1px solid black; width: 20px; height: 20px;"></td><td style="border: 1px solid black; width: 20px; height: 20px;"></td><td style="border: 1px solid black; width: 20px; height: 20px;"></td><td style="border: 1px solid black; width: 20px; height: 20px;"></td> </tr> <tr> <td>Initial value</td> <td colspan="16" style="text-align: center;">Undetermined</td> </tr> <tr> <td>Read/Write</td> <td style="text-align: center;">R/W</td><td style="text-align: center;">R/W</td><td style="text-align: center;">R/W</td><td style="text-align: center;">R/W</td><td style="text-align: center;">R/W</td><td style="text-align: center;">R/W</td><td style="text-align: center;">R/W</td><td style="text-align: center;">R/W</td><td style="text-align: center;">R/W</td><td style="text-align: center;">R/W</td><td style="text-align: center;">R/W</td><td style="text-align: center;">R/W</td><td style="text-align: center;">R/W</td><td style="text-align: center;">R/W</td><td style="text-align: center;">R/W</td><td style="text-align: center;">R/W</td> </tr> <tr> <td></td> <td colspan="16" style="text-align: center;"> <div style="border-top: 1px solid black; width: 100%; margin: 0 auto;"></div> Transfer counter </td> </tr> </table> Block transfer mode <table border="0" style="width: 100%; border-collapse: collapse;"> <tr> <td style="text-align: center;">Bit</td> <td style="text-align: center;">7</td><td style="text-align: center;">6</td><td style="text-align: center;">5</td><td style="text-align: center;">4</td><td style="text-align: center;">3</td><td style="text-align: center;">2</td><td style="text-align: center;">1</td><td style="text-align: center;">0</td> <td style="text-align: center;">7</td><td style="text-align: center;">6</td><td style="text-align: center;">5</td><td style="text-align: center;">4</td><td style="text-align: center;">3</td><td style="text-align: center;">2</td><td style="text-align: center;">1</td><td style="text-align: center;">0</td> </tr> <tr> <td></td> <td style="border: 1px solid black; width: 20px; height: 20px;"></td><td style="border: 1px solid black; width: 20px; height: 20px;"></td><td style="border: 1px solid black; width: 20px; height: 20px;"></td><td style="border: 1px solid black; width: 20px; height: 20px;"></td><td style="border: 1px solid black; width: 20px; height: 20px;"></td><td style="border: 1px solid black; width: 20px; height: 20px;"></td><td style="border: 1px solid black; width: 20px; height: 20px;"></td><td style="border: 1px solid black; width: 20px; height: 20px;"></td> <td style="border: 1px solid black; width: 20px; height: 20px;"></td><td style="border: 1px solid black; width: 20px; height: 20px;"></td><td style="border: 1px solid black; width: 20px; height: 20px;"></td><td style="border: 1px solid black; width: 20px; height: 20px;"></td><td style="border: 1px solid black; width: 20px; height: 20px;"></td><td style="border: 1px solid black; width: 20px; height: 20px;"></td><td style="border: 1px solid black; width: 20px; height: 20px;"></td><td style="border: 1px solid black; width: 20px; height: 20px;"></td> </tr> <tr> <td>Initial value</td> <td colspan="8" style="text-align: center;">Undetermined</td> <td colspan="8" style="text-align: center;">Undetermined</td> </tr> <tr> <td>Read/Write</td> <td style="text-align: center;">R/W</td><td style="text-align: center;">R/W</td><td style="text-align: center;">R/W</td><td style="text-align: center;">R/W</td><td style="text-align: center;">R/W</td><td style="text-align: center;">R/W</td><td style="text-align: center;">R/W</td><td style="text-align: center;">R/W</td> <td style="text-align: center;">R/W</td><td style="text-align: center;">R/W</td><td style="text-align: center;">R/W</td><td style="text-align: center;">R/W</td><td style="text-align: center;">R/W</td><td style="text-align: center;">R/W</td><td style="text-align: center;">R/W</td><td style="text-align: center;">R/W</td> </tr> <tr> <td></td> <td colspan="8" style="text-align: center;"> <div style="border-top: 1px solid black; width: 100%; margin: 0 auto;"></div> ETCR0AH </td> <td colspan="8" style="text-align: center;"> <div style="border-top: 1px solid black; width: 100%; margin: 0 auto;"></div> ETCR0AL </td> </tr> <tr> <td></td> <td colspan="8" style="text-align: center;"> <div style="border-top: 1px solid black; width: 100%; margin: 0 auto;"></div> Block size counter </td> <td colspan="8" style="text-align: center;"> <div style="border-top: 1px solid black; width: 100%; margin: 0 auto;"></div> Initial block size </td> </tr> </table> 																Bit	15	14	13	12	11	10	9	8	7	6	5	4	3	2	1	0																		Initial value	Undetermined																Read/Write	R/W	R/W	R/W	R/W	R/W	R/W	R/W	R/W	R/W	R/W	R/W	R/W	R/W	R/W	R/W	R/W		<div style="border-top: 1px solid black; width: 100%; margin: 0 auto;"></div> Transfer counter																Bit	7	6	5	4	3	2	1	0	7	6	5	4	3	2	1	0																		Initial value	Undetermined								Undetermined								Read/Write	R/W	R/W	R/W	R/W	R/W	R/W	R/W	R/W	R/W	R/W	R/W	R/W	R/W	R/W	R/W	R/W		<div style="border-top: 1px solid black; width: 100%; margin: 0 auto;"></div> ETCR0AH								<div style="border-top: 1px solid black; width: 100%; margin: 0 auto;"></div> ETCR0AL									<div style="border-top: 1px solid black; width: 100%; margin: 0 auto;"></div> Transfer counter								<div style="border-top: 1px solid black; width: 100%; margin: 0 auto;"></div> Initial count								Bit	15	14	13	12	11	10	9	8	7	6	5	4	3	2	1	0																		Initial value	Undetermined																Read/Write	R/W	R/W	R/W	R/W	R/W	R/W	R/W	R/W	R/W	R/W	R/W	R/W	R/W	R/W	R/W	R/W		<div style="border-top: 1px solid black; width: 100%; margin: 0 auto;"></div> Transfer counter																Bit	7	6	5	4	3	2	1	0	7	6	5	4	3	2	1	0																		Initial value	Undetermined								Undetermined								Read/Write	R/W	R/W	R/W	R/W	R/W	R/W	R/W	R/W	R/W	R/W	R/W	R/W	R/W	R/W	R/W	R/W		<div style="border-top: 1px solid black; width: 100%; margin: 0 auto;"></div> ETCR0AH								<div style="border-top: 1px solid black; width: 100%; margin: 0 auto;"></div> ETCR0AL									<div style="border-top: 1px solid black; width: 100%; margin: 0 auto;"></div> Block size counter								<div style="border-top: 1px solid black; width: 100%; margin: 0 auto;"></div> Initial block size							
Bit	15	14	13	12	11	10	9	8	7	6	5	4	3	2	1	0																																																																																																																																																																																																																																																																																																																																																																																					
Initial value	Undetermined																																																																																																																																																																																																																																																																																																																																																																																																				
Read/Write	R/W	R/W	R/W	R/W	R/W	R/W	R/W	R/W	R/W	R/W	R/W	R/W	R/W	R/W	R/W	R/W																																																																																																																																																																																																																																																																																																																																																																																					
	<div style="border-top: 1px solid black; width: 100%; margin: 0 auto;"></div> Transfer counter																																																																																																																																																																																																																																																																																																																																																																																																				
Bit	7	6	5	4	3	2	1	0	7	6	5	4	3	2	1	0																																																																																																																																																																																																																																																																																																																																																																																					
Initial value	Undetermined								Undetermined																																																																																																																																																																																																																																																																																																																																																																																												
Read/Write	R/W	R/W	R/W	R/W	R/W	R/W	R/W	R/W	R/W	R/W	R/W	R/W	R/W	R/W	R/W	R/W																																																																																																																																																																																																																																																																																																																																																																																					
	<div style="border-top: 1px solid black; width: 100%; margin: 0 auto;"></div> ETCR0AH								<div style="border-top: 1px solid black; width: 100%; margin: 0 auto;"></div> ETCR0AL																																																																																																																																																																																																																																																																																																																																																																																												
	<div style="border-top: 1px solid black; width: 100%; margin: 0 auto;"></div> Transfer counter								<div style="border-top: 1px solid black; width: 100%; margin: 0 auto;"></div> Initial count																																																																																																																																																																																																																																																																																																																																																																																												
Bit	15	14	13	12	11	10	9	8	7	6	5	4	3	2	1	0																																																																																																																																																																																																																																																																																																																																																																																					
Initial value	Undetermined																																																																																																																																																																																																																																																																																																																																																																																																				
Read/Write	R/W	R/W	R/W	R/W	R/W	R/W	R/W	R/W	R/W	R/W	R/W	R/W	R/W	R/W	R/W	R/W																																																																																																																																																																																																																																																																																																																																																																																					
	<div style="border-top: 1px solid black; width: 100%; margin: 0 auto;"></div> Transfer counter																																																																																																																																																																																																																																																																																																																																																																																																				
Bit	7	6	5	4	3	2	1	0	7	6	5	4	3	2	1	0																																																																																																																																																																																																																																																																																																																																																																																					
Initial value	Undetermined								Undetermined																																																																																																																																																																																																																																																																																																																																																																																												
Read/Write	R/W	R/W	R/W	R/W	R/W	R/W	R/W	R/W	R/W	R/W	R/W	R/W	R/W	R/W	R/W	R/W																																																																																																																																																																																																																																																																																																																																																																																					
	<div style="border-top: 1px solid black; width: 100%; margin: 0 auto;"></div> ETCR0AH								<div style="border-top: 1px solid black; width: 100%; margin: 0 auto;"></div> ETCR0AL																																																																																																																																																																																																																																																																																																																																																																																												
	<div style="border-top: 1px solid black; width: 100%; margin: 0 auto;"></div> Block size counter								<div style="border-top: 1px solid black; width: 100%; margin: 0 auto;"></div> Initial block size																																																																																																																																																																																																																																																																																																																																																																																												

IOAR0A—I/O Address Register 0A					H'FFF26	DMAC0		
Bit	7	6	5	4	3	2	1	0
Initial value				Undetermined				
Read/Write	R/W	R/W	R/W	R/W	R/W	R/W	R/W	R/W
						Short address mode : source or destination address		
						Full address mode : not used		

DTCR0A—Data Transfer Control Register 0A					H'FFF27		DMAC0																																			
<ul style="list-style-type: none"> Short address mode 																																										
Bit	7	6	5	4	3	2	1	0																																		
	DTE	DTSZ	DTID	RPE	DTIE	DTS2	DTS1	DTS0																																		
Initial value	0	0	0	0	0	0	0	0																																		
Read/Write	R/W	R/W	R/W	R/W	R/W	R/W	R/W	R/W																																		
						<table border="1" style="width:100%; border-collapse: collapse;"> <thead> <tr> <th colspan="3" style="text-align: left;">Data transfer select</th> </tr> <tr> <th style="text-align: center;">Bit 2</th> <th style="text-align: center;">Bit 1</th> <th style="text-align: center;">Bit 0</th> <th rowspan="2" style="text-align: left;">Data Transfer Activation Source</th> </tr> <tr> <th style="text-align: center;">DTS2</th> <th style="text-align: center;">DTS1</th> <th style="text-align: center;">DTS0</th> </tr> </thead> <tbody> <tr> <td rowspan="4" style="text-align: center;">0</td> <td rowspan="2" style="text-align: center;">0</td> <td style="text-align: center;">0</td> <td>Compare match/input capture A interrupt from 16-bit timer channel 0</td> </tr> <tr> <td style="text-align: center;">1</td> <td>Compare match/input capture A interrupt from 16-bit timer channel 1</td> </tr> <tr> <td rowspan="2" style="text-align: center;">1</td> <td style="text-align: center;">0</td> <td>Compare match/input capture A interrupt from 16-bit timer channel 2</td> </tr> <tr> <td style="text-align: center;">1</td> <td>A/D converter conversion end interrupt</td> </tr> <tr> <td rowspan="3" style="text-align: center;">1</td> <td rowspan="2" style="text-align: center;">0</td> <td style="text-align: center;">0</td> <td>SCI0 transmit-data-empty interrupt</td> </tr> <tr> <td style="text-align: center;">1</td> <td>SCI0 receive-data-full interrupt</td> </tr> <tr> <td style="text-align: center;">1</td> <td style="text-align: center;">0</td> <td>Transfer in full address mode</td> </tr> <tr> <td></td> <td></td> <td style="text-align: center;">1</td> <td>Transfer in full address mode</td> </tr> </tbody> </table>			Data transfer select			Bit 2	Bit 1	Bit 0	Data Transfer Activation Source	DTS2	DTS1	DTS0	0	0	0	Compare match/input capture A interrupt from 16-bit timer channel 0	1	Compare match/input capture A interrupt from 16-bit timer channel 1	1	0	Compare match/input capture A interrupt from 16-bit timer channel 2	1	A/D converter conversion end interrupt	1	0	0	SCI0 transmit-data-empty interrupt	1	SCI0 receive-data-full interrupt	1	0	Transfer in full address mode			1	Transfer in full address mode
Data transfer select																																										
Bit 2	Bit 1	Bit 0	Data Transfer Activation Source																																							
DTS2	DTS1	DTS0																																								
0	0	0	Compare match/input capture A interrupt from 16-bit timer channel 0																																							
		1	Compare match/input capture A interrupt from 16-bit timer channel 1																																							
	1	0	Compare match/input capture A interrupt from 16-bit timer channel 2																																							
		1	A/D converter conversion end interrupt																																							
1	0	0	SCI0 transmit-data-empty interrupt																																							
		1	SCI0 receive-data-full interrupt																																							
	1	0	Transfer in full address mode																																							
		1	Transfer in full address mode																																							
						<table border="1" style="width:100%; border-collapse: collapse;"> <thead> <tr> <th colspan="2" style="text-align: left;">Data transfer interrupt enable</th> </tr> </thead> <tbody> <tr> <td style="text-align: center;">0</td> <td>Interrupt requested by DTE bit is disabled</td> </tr> <tr> <td style="text-align: center;">1</td> <td>Interrupt requested by DTE bit is enabled</td> </tr> </tbody> </table>			Data transfer interrupt enable		0	Interrupt requested by DTE bit is disabled	1	Interrupt requested by DTE bit is enabled																												
Data transfer interrupt enable																																										
0	Interrupt requested by DTE bit is disabled																																									
1	Interrupt requested by DTE bit is enabled																																									
						<table border="1" style="width:100%; border-collapse: collapse;"> <thead> <tr> <th colspan="3" style="text-align: left;">Repeat enable</th> </tr> <tr> <th style="text-align: center;">RPE</th> <th style="text-align: center;">DTIE</th> <th style="text-align: left;">Description</th> </tr> </thead> <tbody> <tr> <td rowspan="2" style="text-align: center;">0</td> <td style="text-align: center;">0</td> <td>I/O mode</td> </tr> <tr> <td style="text-align: center;">1</td> <td>Repeat mode</td> </tr> <tr> <td rowspan="2" style="text-align: center;">1</td> <td style="text-align: center;">0</td> <td>Repeat mode</td> </tr> <tr> <td style="text-align: center;">1</td> <td>Idle mode</td> </tr> </tbody> </table>			Repeat enable			RPE	DTIE	Description	0	0	I/O mode	1	Repeat mode	1	0	Repeat mode	1	Idle mode																		
Repeat enable																																										
RPE	DTIE	Description																																								
0	0	I/O mode																																								
	1	Repeat mode																																								
1	0	Repeat mode																																								
	1	Idle mode																																								
						<table border="1" style="width:100%; border-collapse: collapse;"> <thead> <tr> <th colspan="2" style="text-align: left;">Data transfer increment/decrement</th> </tr> </thead> <tbody> <tr> <td style="text-align: center;">0</td> <td>Incremented: If DTSZ = 0, MAR is incremented by 1 after each transfer If DTSZ = 1, MAR is incremented by 2 after each transfer</td> </tr> <tr> <td style="text-align: center;">1</td> <td>Decrement: If DTSZ = 0, MAR is decremented by 1 after each transfer If DTSZ = 1, MAR is decremented by 2 after each transfer</td> </tr> </tbody> </table>			Data transfer increment/decrement		0	Incremented: If DTSZ = 0, MAR is incremented by 1 after each transfer If DTSZ = 1, MAR is incremented by 2 after each transfer	1	Decrement: If DTSZ = 0, MAR is decremented by 1 after each transfer If DTSZ = 1, MAR is decremented by 2 after each transfer																												
Data transfer increment/decrement																																										
0	Incremented: If DTSZ = 0, MAR is incremented by 1 after each transfer If DTSZ = 1, MAR is incremented by 2 after each transfer																																									
1	Decrement: If DTSZ = 0, MAR is decremented by 1 after each transfer If DTSZ = 1, MAR is decremented by 2 after each transfer																																									
						<table border="1" style="width:100%; border-collapse: collapse;"> <thead> <tr> <th colspan="2" style="text-align: left;">Data transfer size</th> </tr> </thead> <tbody> <tr> <td style="text-align: center;">0</td> <td>Byte-size transfer</td> </tr> <tr> <td style="text-align: center;">1</td> <td>Word-size transfer</td> </tr> </tbody> </table>			Data transfer size		0	Byte-size transfer	1	Word-size transfer																												
Data transfer size																																										
0	Byte-size transfer																																									
1	Word-size transfer																																									
						<table border="1" style="width:100%; border-collapse: collapse;"> <thead> <tr> <th colspan="2" style="text-align: left;">Data transfer enable</th> </tr> </thead> <tbody> <tr> <td style="text-align: center;">0</td> <td>Data transfer is disabled</td> </tr> <tr> <td style="text-align: center;">1</td> <td>Data transfer is enabled</td> </tr> </tbody> </table>			Data transfer enable		0	Data transfer is disabled	1	Data transfer is enabled																												
Data transfer enable																																										
0	Data transfer is disabled																																									
1	Data transfer is enabled																																									

DTCR0A—Data Transfer Control Register 0A (cont)						H'FFF27	DMAC0																	
• Full address mode																								
Bit	7	6	5	4	3	2	1	0																
	DTE	DTSZ	SAID	SAIDE	DTIE	DTS2A	DTS1A	DTS0A																
Initial value	0	0	0	0	0	0	0	0																
Read/Write	R/W	R/W	R/W	R/W	R/W	R/W	R/W	R/W																
							Data transfer select 0A <table border="1"> <tr><td>0</td><td>Normal mode</td></tr> <tr><td>1</td><td>Block transfer mode</td></tr> </table>		0	Normal mode	1	Block transfer mode												
0	Normal mode																							
1	Block transfer mode																							
					Data transfer select 2A and 1A <table border="1"> <tr><td colspan="2">Set both bits to 1</td></tr> </table>		Set both bits to 1																	
Set both bits to 1																								
					Data transfer interrupt enable <table border="1"> <tr><td>0</td><td>Interrupt requested by DTE bit is disabled</td></tr> <tr><td>1</td><td>Interrupt requested by DTE bit is enabled</td></tr> </table>		0	Interrupt requested by DTE bit is disabled	1	Interrupt requested by DTE bit is enabled														
0	Interrupt requested by DTE bit is disabled																							
1	Interrupt requested by DTE bit is enabled																							
			Source address increment/decrement (bit 5) Source address increment/decrement enable (bit 4)																					
			<table border="1"> <thead> <tr> <th>Bit 5</th> <th>Bit 4</th> <th>Increment/Decrement Enable</th> </tr> <tr> <th>SAID</th> <th>SAIDE</th> <th></th> </tr> </thead> <tbody> <tr> <td rowspan="2">0</td> <td>0</td> <td>MARA is held fixed</td> </tr> <tr> <td>1</td> <td>Incremented: If DTSZ = 0, MARA is incremented by 1 after each transfer If DTSZ = 1, MARA is incremented by 2 after each transfer</td> </tr> <tr> <td rowspan="2">1</td> <td>0</td> <td>MARA is held fixed</td> </tr> <tr> <td>1</td> <td>Decrement: If DTSZ = 0, MARA is decremented by 1 after each transfer If DTSZ = 1, MARA is decremented by 2 after each transfer</td> </tr> </tbody> </table>		Bit 5	Bit 4	Increment/Decrement Enable	SAID	SAIDE		0	0	MARA is held fixed	1	Incremented: If DTSZ = 0, MARA is incremented by 1 after each transfer If DTSZ = 1, MARA is incremented by 2 after each transfer	1	0	MARA is held fixed	1	Decrement: If DTSZ = 0, MARA is decremented by 1 after each transfer If DTSZ = 1, MARA is decremented by 2 after each transfer				
Bit 5	Bit 4	Increment/Decrement Enable																						
SAID	SAIDE																							
0	0	MARA is held fixed																						
	1	Incremented: If DTSZ = 0, MARA is incremented by 1 after each transfer If DTSZ = 1, MARA is incremented by 2 after each transfer																						
1	0	MARA is held fixed																						
	1	Decrement: If DTSZ = 0, MARA is decremented by 1 after each transfer If DTSZ = 1, MARA is decremented by 2 after each transfer																						
			Data transfer size <table border="1"> <tr><td>0</td><td>Byte-size transfer</td></tr> <tr><td>1</td><td>Word-size transfer</td></tr> </table>		0	Byte-size transfer	1	Word-size transfer																
0	Byte-size transfer																							
1	Word-size transfer																							
			Data transfer enable <table border="1"> <tr><td>0</td><td>Data transfer is disabled</td></tr> <tr><td>1</td><td>Data transfer is enabled</td></tr> </table>		0	Data transfer is disabled	1	Data transfer is enabled																
0	Data transfer is disabled																							
1	Data transfer is enabled																							

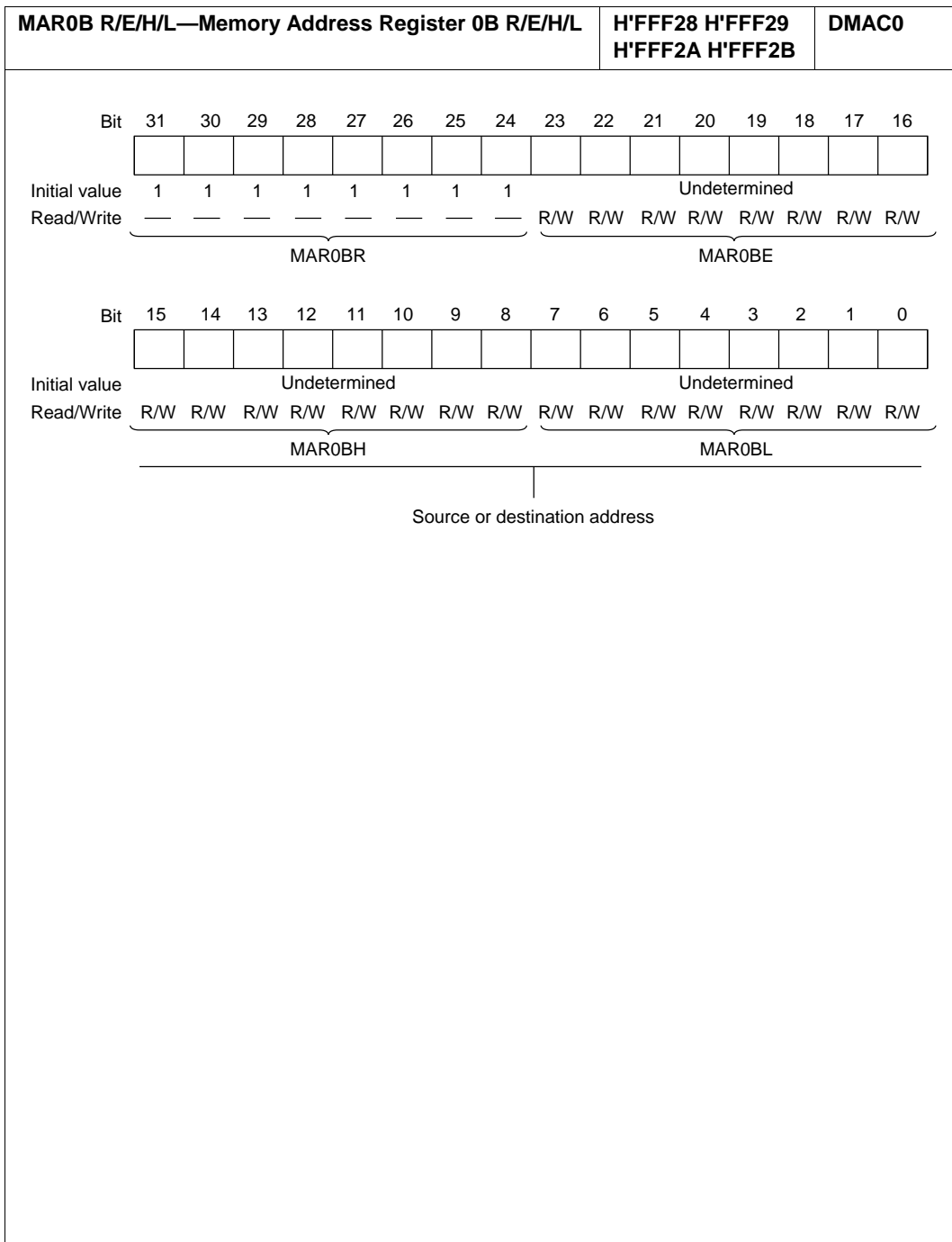

IOAR0B—I/O Address Register 0B	H'FFF2E	DMAC0						
Bit	7	6	5	4	3	2	1	0
	□	□	□	□	□	□	□	□
Initial value				Undetermined				
Read/Write	R/W	R/W	R/W	R/W	R/W	R/W	R/W	R/W
	<hr style="width: 80%; margin: 0 auto;"/>							
	Short address mode : source or destination address							
	Full address mode : not used							

DTCR0B—Data Transfer Control Register 0B						H'FFF2F	DMAC0																																						
• Short address mode																																													
Bit	7	6	5	4	3	2	1	0																																					
	DTE	DTSZ	DTID	RPE	DTIE	DTS2	DTS1	DTS0																																					
Initial value	0	0	0	0	0	0	0	0																																					
Read/Write	R/W	R/W	R/W	R/W	R/W	R/W	R/W	R/W																																					
						Data transfer select																																							
						<table border="1"> <thead> <tr> <th>Bit 2</th> <th>Bit 1</th> <th>Bit 0</th> <th>Data Transfer Activation Source</th> </tr> <tr> <th>DTS2</th> <th>DTS1</th> <th>DTS0</th> <th></th> </tr> </thead> <tbody> <tr> <td rowspan="3">0</td> <td rowspan="2">0</td> <td>0</td> <td>Compare match/input capture A interrupt from 16-bit timer channel 0</td> </tr> <tr> <td>1</td> <td>Compare match/input capture A interrupt from 16-bit timer channel 1</td> </tr> <tr> <td>1</td> <td>0</td> <td>Compare match/input capture A interrupt from 16-bit timer channel 2</td> </tr> <tr> <td rowspan="4">1</td> <td rowspan="2">1</td> <td>1</td> <td>A/D converter conversion end interrupt</td> </tr> <tr> <td>0</td> <td>SCI0 transmit-data-empty interrupt</td> </tr> <tr> <td rowspan="2">0</td> <td>1</td> <td>SCI0 receive-data-full interrupt</td> </tr> <tr> <td>0</td> <td>Falling edge of DREQ input</td> </tr> <tr> <td></td> <td></td> <td></td> <td></td> <td></td> <td></td> <td></td> <td>1</td> <td>Low level of DREQ input</td> </tr> </tbody> </table>			Bit 2	Bit 1	Bit 0	Data Transfer Activation Source	DTS2	DTS1	DTS0		0	0	0	Compare match/input capture A interrupt from 16-bit timer channel 0	1	Compare match/input capture A interrupt from 16-bit timer channel 1	1	0	Compare match/input capture A interrupt from 16-bit timer channel 2	1	1	1	A/D converter conversion end interrupt	0	SCI0 transmit-data-empty interrupt	0	1	SCI0 receive-data-full interrupt	0	Falling edge of DREQ input								1	Low level of DREQ input
Bit 2	Bit 1	Bit 0	Data Transfer Activation Source																																										
DTS2	DTS1	DTS0																																											
0	0	0	Compare match/input capture A interrupt from 16-bit timer channel 0																																										
		1	Compare match/input capture A interrupt from 16-bit timer channel 1																																										
	1	0	Compare match/input capture A interrupt from 16-bit timer channel 2																																										
1	1	1	A/D converter conversion end interrupt																																										
		0	SCI0 transmit-data-empty interrupt																																										
	0	1	SCI0 receive-data-full interrupt																																										
		0	Falling edge of DREQ input																																										
							1	Low level of DREQ input																																					
						Data transfer interrupt enable																																							
						<table border="1"> <tbody> <tr> <td>0</td> <td>Interrupt requested by DTE bit is disabled</td> </tr> <tr> <td>1</td> <td>Interrupt requested by DTE bit is enabled</td> </tr> </tbody> </table>			0	Interrupt requested by DTE bit is disabled	1	Interrupt requested by DTE bit is enabled																																	
0	Interrupt requested by DTE bit is disabled																																												
1	Interrupt requested by DTE bit is enabled																																												
						Repeat enable																																							
						<table border="1"> <thead> <tr> <th>RPE</th> <th>DTIE</th> <th>Description</th> </tr> </thead> <tbody> <tr> <td rowspan="2">0</td> <td>0</td> <td rowspan="2">I/O mode</td> </tr> <tr> <td>1</td> </tr> <tr> <td rowspan="2">1</td> <td>0</td> <td>Repeat mode</td> </tr> <tr> <td>1</td> <td>Idle mode</td> </tr> </tbody> </table>			RPE	DTIE	Description	0	0	I/O mode	1	1	0	Repeat mode	1	Idle mode																									
RPE	DTIE	Description																																											
0	0	I/O mode																																											
	1																																												
1	0	Repeat mode																																											
	1	Idle mode																																											
						Data transfer increment/decrement																																							
						<table border="1"> <tbody> <tr> <td>0</td> <td>Incremented: If DTSZ = 0, MAR is incremented by 1 after each transfer If DTSZ = 1, MAR is incremented by 2 after each transfer</td> </tr> <tr> <td>1</td> <td>Decrement: If DTSZ = 0, MAR is decremented by 1 after each transfer If DTSZ = 1, MAR is decremented by 2 after each transfer</td> </tr> </tbody> </table>			0	Incremented: If DTSZ = 0, MAR is incremented by 1 after each transfer If DTSZ = 1, MAR is incremented by 2 after each transfer	1	Decrement: If DTSZ = 0, MAR is decremented by 1 after each transfer If DTSZ = 1, MAR is decremented by 2 after each transfer																																	
0	Incremented: If DTSZ = 0, MAR is incremented by 1 after each transfer If DTSZ = 1, MAR is incremented by 2 after each transfer																																												
1	Decrement: If DTSZ = 0, MAR is decremented by 1 after each transfer If DTSZ = 1, MAR is decremented by 2 after each transfer																																												
						Data transfer size																																							
						<table border="1"> <tbody> <tr> <td>0</td> <td>Byte-size transfer</td> </tr> <tr> <td>1</td> <td>Word-size transfer</td> </tr> </tbody> </table>			0	Byte-size transfer	1	Word-size transfer																																	
0	Byte-size transfer																																												
1	Word-size transfer																																												
						Data transfer enable																																							
						<table border="1"> <tbody> <tr> <td>0</td> <td>Data transfer is disabled</td> </tr> <tr> <td>1</td> <td>Data transfer is enabled</td> </tr> </tbody> </table>			0	Data transfer is disabled	1	Data transfer is enabled																																	
0	Data transfer is disabled																																												
1	Data transfer is enabled																																												

DTCR0B—Data Transfer Control Register 0B (cont) **H'FFF2F** **DMAC0**

• Full address mode

Bit	7	6	5	4	3	2	1	0
	DTME	—	DAID	DAIDE	TMS	DTS2B	DTS1B	DTS0B
Initial value	0	0	0	0	0	0	0	0
Read/Write	R/W	R/W	R/W	R/W	R/W	R/W	R/W	R/W

Data transfer master enable

0	Data transfer is disabled
1	Data transfer is enabled

Data transfer select 2B to 0B

Bit 2 DTS2B	Bit 1 DTS1B	Bit 0 DTS0B	Data Transfer Activation Source	
			Normal Mode	Block Transfer Mode
0	0	0	Auto-request (burst mode)	Compare match/input capture A interrupt from 16-bit timer channel 0
		1	Not available	Compare match/input capture A interrupt from 16-bit timer channel 1
	1	0	Auto-request (cycle-steal mode)	Compare match/input capture A interrupt from 16-bit timer channel 2
		1	Not available	A/D converter conversion end interrupt
1	0	0	Not available	Not available
		1	Not available	Not available
	1	0	Falling edge input of DREQ	Falling edge input of DREQ
		1	Low level input at DREQ	Not available

Transfer mode select

0	Destination is the block area in block transfer mode
1	Source is the block area in block transfer mode

Destination address increment/decrement (bit 5)
 Destination address increment/decrement enable (bit 4)

Bit 5 DAID	Bit 4 DAIDE	Increment/Decrement Enable
0	0	MARB is held fixed
	1	Incremented: If DTSZ = 0, MARB is incremented by 1 after each transfer If DTSZ = 1, MARB is incremented by 2 after each transfer
1	0	MARB is held fixed
	1	Decrement: If DTSZ = 0, MARB is decremented by 1 after each transfer If DTSZ = 1, MARB is decremented by 2 after each transfer



MAR1A R/E/H/L—Memory Address Register 1A R/E/H/L										H'FFF30 H'FFF31 H'FFF32 H'FFF33				DMAC1								
Bit	31	30	29	28	27	26	25	24	23	22	21	20	19	18	17	16						
Initial value	1	1	1	1	1	1	1	1	Undetermined													
Read/Write	—	—	—	—	—	—	—	—	R/W	R/W	R/W	R/W	R/W	R/W	R/W	R/W						
	MAR1AR								MAR1AE													
Bit	15	14	13	12	11	10	9	8	7	6	5	4	3	2	1	0						
Initial value	Undetermined								Undetermined													
Read/Write	R/W	R/W	R/W	R/W	R/W	R/W	R/W	R/W	R/W	R/W	R/W	R/W	R/W	R/W	R/W	R/W						
	MAR1AH								MAR1AL													
Note: Bit functions are the same as for DMAC0.																						
ETCR1A H/L—Execute Transfer Count Register 1A H/L										H'FFF34 H'FFF35				DMAC1								
Bit	15	14	13	12	11	10	9	8	7	6	5	4	3	2	1	0						
Initial value	Undetermined																					
Read/Write	R/W	R/W	R/W	R/W	R/W	R/W	R/W	R/W	R/W	R/W	R/W	R/W	R/W	R/W	R/W	R/W						
Bit	7	6	5	4	3	2	1	0	7	6	5	4	3	2	1	0						
Initial value	Undetermined								Undetermined													
Read/Write	R/W	R/W	R/W	R/W	R/W	R/W	R/W	R/W	R/W	R/W	R/W	R/W	R/W	R/W	R/W	R/W						
	ETCR1AH								ETCR1AL													
Note: Bit functions are the same as for DMAC0.																						

IOAR1A—I/O Address Register 1A					H'FFF36	DMAC1		
Bit	7	6	5	4	3	2	1	0
Initial value				Undetermined				
Read/Write	R/W	R/W	R/W	R/W	R/W	R/W	R/W	R/W
Note: Bit functions are the same as for DMAC0.								
DTCR1A—Data Transfer Control Register 1A					H'FFF37	DMAC1		
• Short address mode								
Bit	7	6	5	4	3	2	1	0
	DTE	DTSZ	DTID	RPE	DTIE	DTS2	DTS1	DTS0
Initial value	0	0	0	0	0	0	0	0
Read/Write	R/W	R/W	R/W	R/W	R/W	R/W	R/W	R/W
• Full address mode								
Bit	7	6	5	4	3	2	1	0
	DTE	DTSZ	SAID	SAIDE	DTIE	DTS2A	DTS1A	DTS0A
Initial value	0	0	0	0	0	0	0	0
Read/Write	R/W	R/W	R/W	R/W	R/W	R/W	R/W	R/W
Note: Bit functions are the same as for DMAC0.								

MAR1B R/E/H/L—Memory Address Register 1B R/E/H/L										H'FFF38 H'FFF39 H'FFF3A H'FFF3B		DMAC1								
Bit	31	30	29	28	27	26	25	24	23	22	21	20	19	18	17	16				
Initial value	1	1	1	1	1	1	1	1	Undetermined											
Read/Write	—	—	—	—	—	—	—	—	R/W	R/W	R/W	R/W	R/W	R/W	R/W	R/W				
	MAR1BR								MAR1BE											
Bit	15	14	13	12	11	10	9	8	7	6	5	4	3	2	1	0				
Initial value	Undetermined								Undetermined											
Read/Write	R/W	R/W	R/W	R/W	R/W	R/W	R/W	R/W	R/W	R/W	R/W	R/W	R/W	R/W	R/W	R/W				
	MAR1BH								MAR1BL											
Note: Bit functions are the same as for DMAC0.																				
ETCR1B H/L—Execute Transfer Count Register 1B H/L										H'FFF3C H'FFF3D		DMAC1								
Bit	15	14	13	12	11	10	9	8	7	6	5	4	3	2	1	0				
Initial value	Undetermined																			
Read/Write	R/W	R/W	R/W	R/W	R/W	R/W	R/W	R/W	R/W	R/W	R/W	R/W	R/W	R/W	R/W	R/W				
Bit	7	6	5	4	3	2	1	0	7	6	5	4	3	2	1	0				
Initial value	Undetermined								Undetermined											
Read/Write	R/W	R/W	R/W	R/W	R/W	R/W	R/W	R/W	R/W	R/W	R/W	R/W	R/W	R/W	R/W	R/W				
	ETCR1BH								ETCR1BL											
Note: Bit functions are the same as for DMAC0.																				

IOAR1B—I/O Address Register 1B					H'FFF3E	DMAC1		
Bit	7	6	5	4	3	2	1	0
Initial value				Undetermined				
Read/Write	R/W	R/W	R/W	R/W	R/W	R/W	R/W	R/W
Note: Bit functions are the same as for DMAC0.								
DTCR1B—Data Transfer Control Register 1B					H'FFF3F	DMAC1		
• Short address mode								
Bit	7	6	5	4	3	2	1	0
	DTE	DTSZ	DTID	RPE	DTIE	DTS2	DTS1	DTS0
Initial value	0	0	0	0	0	0	0	0
Read/Write	R/W	R/W	R/W	R/W	R/W	R/W	R/W	R/W
• Full address mode								
Bit	7	6	5	4	3	2	1	0
	DTME	—	DAID	DAIDE	TMS	DTS2B	DTS1B	DTS0B
Initial value	0	0	0	0	0	0	0	0
Read/Write	R/W	R/W	R/W	R/W	R/W	R/W	R/W	R/W
Note: Bit functions are the same as for DMAC0.								

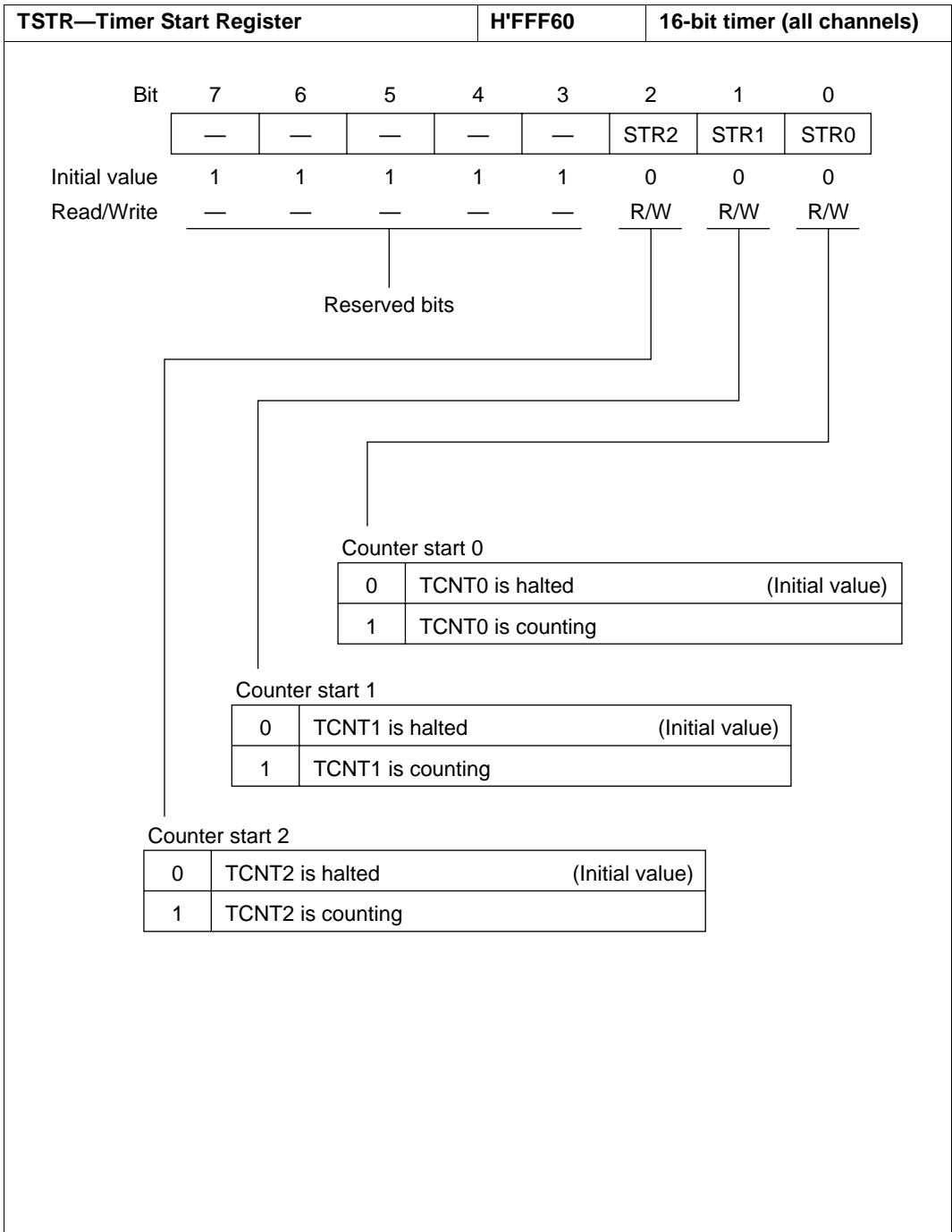

TSNC—Timer Synchro Register					H'FFF61	16-bit timer (all channels)						
Bit	7	6	5	4	3	2	1	0				
	—	—	—	—	—	SYNC2	SYNC1	SYNC0				
Initial value	1	1	1	1	1	0	0	0				
Read/Write	—	—	—	—	—	R/W	R/W	R/W				
Reserved bits												
						Timer synchronization 0						
						<table border="1"> <tr> <td style="text-align: center;">0</td> <td>Channel 0 timer counter (TCNT0) operates independently (TCNT0 presetting/clearing is unrelated to other channels) (Initial value)</td> </tr> <tr> <td style="text-align: center;">1</td> <td>Channel 0 operates synchronously TCNT0 synchronous presetting/synchronous clearing is possible</td> </tr> </table>			0	Channel 0 timer counter (TCNT0) operates independently (TCNT0 presetting/clearing is unrelated to other channels) (Initial value)	1	Channel 0 operates synchronously TCNT0 synchronous presetting/synchronous clearing is possible
0	Channel 0 timer counter (TCNT0) operates independently (TCNT0 presetting/clearing is unrelated to other channels) (Initial value)											
1	Channel 0 operates synchronously TCNT0 synchronous presetting/synchronous clearing is possible											
						Timer synchronization 1						
						<table border="1"> <tr> <td style="text-align: center;">0</td> <td>Channel 1 timer counter (TCNT1) operates independently (TCNT1 presetting/clearing is unrelated to other channels) (Initial value)</td> </tr> <tr> <td style="text-align: center;">1</td> <td>Channel 1 operates synchronously TCNT1 synchronous presetting/synchronous clearing is possible</td> </tr> </table>			0	Channel 1 timer counter (TCNT1) operates independently (TCNT1 presetting/clearing is unrelated to other channels) (Initial value)	1	Channel 1 operates synchronously TCNT1 synchronous presetting/synchronous clearing is possible
0	Channel 1 timer counter (TCNT1) operates independently (TCNT1 presetting/clearing is unrelated to other channels) (Initial value)											
1	Channel 1 operates synchronously TCNT1 synchronous presetting/synchronous clearing is possible											
						Timer synchronization 2						
						<table border="1"> <tr> <td style="text-align: center;">0</td> <td>Channel 2 timer counter (TCNT2) operates independently (TCNT2 presetting/clearing is unrelated to other channels) (Initial value)</td> </tr> <tr> <td style="text-align: center;">1</td> <td>Channel 2 operates synchronously TCNT2 synchronous presetting/synchronous clearing is possible</td> </tr> </table>			0	Channel 2 timer counter (TCNT2) operates independently (TCNT2 presetting/clearing is unrelated to other channels) (Initial value)	1	Channel 2 operates synchronously TCNT2 synchronous presetting/synchronous clearing is possible
0	Channel 2 timer counter (TCNT2) operates independently (TCNT2 presetting/clearing is unrelated to other channels) (Initial value)											
1	Channel 2 operates synchronously TCNT2 synchronous presetting/synchronous clearing is possible											

TMDR—Timer Mode Register			H'FFF62			16-bit timer (all channels)		
Bit	7	6	5	4	3	2	1	0
	—	MDF	FDIR	—	—	PWM2	PWM1	PWM0
Initial value	1	0	0	1	1	0	0	0
Read/Write	—	R/W	R/W	—	—	R/W	R/W	R/W

0	Channel 0 operates normally (Initial value)
1	Channel 0 operates in PWM mode

0	Channel 1 operates normally (Initial value)
1	Channel 1 operates in PWM mode

0	Channel 2 operates normally (Initial value)
1	Channel 2 operates in PWM mode

0	OVF is set to 1 in TISRC when TCNT2 overflows or underflows (Initial value)
1	OVF is set to 1 in TISRC when TCNT2 overflows

0	Channel 2 operates normally (Initial value)
1	Channel 2 operates in phase counting mode

TOLR—Timer Output Level Setting Register			H'FFF63			16-bit timer (all channels)		
Bit	7	6	5	4	3	2	1	0
	—	—	TOB2	TOA2	TOB1	TOA1	TOB0	TOA0
Initial value	1	1	0	0	0	0	0	0
Read/Write	—	—	W	W	W	W	W	W

Output level setting A0

0	TIOCA ₀ is 0	(Initial value)
1	TIOCA ₀ is 1	

Output level setting B0

0	TIOCB ₀ is 0	(Initial value)
1	TIOCB ₀ is 1	

Output level setting A1

0	TIOCA ₁ is 0	(Initial value)
1	TIOCA ₁ is 1	

Output level setting B1

0	TIOCB ₁ is 0	(Initial value)
1	TIOCB ₁ is 1	

Output level setting A2

0	TIOCA ₂ is 0	(Initial value)
1	TIOCA ₂ is 1	

Output level setting B2

0	TIOCB ₂ is 0	(Initial value)
1	TIOCB ₂ is 1	

TISRA—Timer Interrupt Status Register A		H'FFF64		16-bit timer (all channels)																																																										
Bit:	7	6	5	4	3	2	1	0																																																						
	—	IMIEA2	IMIEA1	IMIEA0	—	IMFA2	IMFA1	IMFA0																																																						
Initial value:	1	0	0	0	1	0	0	0																																																						
Read/Write:	—	R/W	R/W	R/W	—	R/(W)*	R/(W)*	R/(W)*																																																						
<p>Input capture/compare match flag A0</p> <table border="1"> <tr> <td></td> <td>[Clearing conditions]</td> <td>(Initial value)</td> </tr> <tr> <td>0</td> <td>Read IMFA0 when IMFA0=1, then write 0 in IMFA0 DMAC activated by IMIA0 interrupt.</td> <td></td> </tr> <tr> <td></td> <td>[Setting conditions]</td> <td></td> </tr> <tr> <td>1</td> <td>TCNT0=GRA0 when GRA0 functions as an output compare register. TCNT0 value is transferred to GRA0 by an input capture signal when GRA0 functions as an input capture register.</td> <td></td> </tr> </table> <p>Input capture/compare match flag A1</p> <table border="1"> <tr> <td></td> <td>[Clearing conditions]</td> <td>(Initial value)</td> </tr> <tr> <td>0</td> <td>Read IMFA1 when IMFA1=1, then write 0 in IMFA1 DMAC activated by IMIA1 interrupt.</td> <td></td> </tr> <tr> <td></td> <td>[Setting conditions]</td> <td></td> </tr> <tr> <td>1</td> <td>TCNT1=GRA1 when GRA1 functions as an output compare register. TCNT1 value is transferred to GRA1 by an input capture signal when GRA1 functions as an input capture register.</td> <td></td> </tr> </table> <p>Input capture/compare match flag A2</p> <table border="1"> <tr> <td></td> <td>[Clearing conditions]</td> <td>(Initial value)</td> </tr> <tr> <td>0</td> <td>Read IMFA2 when IMFA2=1, then write 0 in IMFA2 DMAC activated by IMIA2 interrupt.</td> <td></td> </tr> <tr> <td></td> <td>[Setting conditions]</td> <td></td> </tr> <tr> <td>1</td> <td>TCNT2=GRA2 when GRA2 functions as an output compare register. TCNT2 value is transferred to GRA2 by an input capture signal when GRA2 functions as an input capture register.</td> <td></td> </tr> </table> <p>Input capture/compare match interrupt enable A0</p> <table border="1"> <tr> <td>0</td> <td>IMIA0 interrupt requested by IMFA0 flag is disabled</td> <td>(Initial value)</td> </tr> <tr> <td>1</td> <td>IMIA0 interrupt requested by IMFA0 is enabled</td> <td></td> </tr> </table> <p>Input capture/compare match interrupt enable A1</p> <table border="1"> <tr> <td>0</td> <td>IMIA1 interrupt requested by IMFA1 flag is disabled</td> <td>(Initial value)</td> </tr> <tr> <td>1</td> <td>IMIA1 interrupt requested by IMFA1 is enabled</td> <td></td> </tr> </table> <p>Input capture/compare match interrupt enable A2</p> <table border="1"> <tr> <td>0</td> <td>IMIA2 interrupt requested by IMFA2 flag is disabled</td> <td>(Initial value)</td> </tr> <tr> <td>1</td> <td>IMIA2 interrupt requested by IMFA2 is enabled</td> <td></td> </tr> </table>										[Clearing conditions]	(Initial value)	0	Read IMFA0 when IMFA0=1, then write 0 in IMFA0 DMAC activated by IMIA0 interrupt.			[Setting conditions]		1	TCNT0=GRA0 when GRA0 functions as an output compare register. TCNT0 value is transferred to GRA0 by an input capture signal when GRA0 functions as an input capture register.			[Clearing conditions]	(Initial value)	0	Read IMFA1 when IMFA1=1, then write 0 in IMFA1 DMAC activated by IMIA1 interrupt.			[Setting conditions]		1	TCNT1=GRA1 when GRA1 functions as an output compare register. TCNT1 value is transferred to GRA1 by an input capture signal when GRA1 functions as an input capture register.			[Clearing conditions]	(Initial value)	0	Read IMFA2 when IMFA2=1, then write 0 in IMFA2 DMAC activated by IMIA2 interrupt.			[Setting conditions]		1	TCNT2=GRA2 when GRA2 functions as an output compare register. TCNT2 value is transferred to GRA2 by an input capture signal when GRA2 functions as an input capture register.		0	IMIA0 interrupt requested by IMFA0 flag is disabled	(Initial value)	1	IMIA0 interrupt requested by IMFA0 is enabled		0	IMIA1 interrupt requested by IMFA1 flag is disabled	(Initial value)	1	IMIA1 interrupt requested by IMFA1 is enabled		0	IMIA2 interrupt requested by IMFA2 flag is disabled	(Initial value)	1	IMIA2 interrupt requested by IMFA2 is enabled	
	[Clearing conditions]	(Initial value)																																																												
0	Read IMFA0 when IMFA0=1, then write 0 in IMFA0 DMAC activated by IMIA0 interrupt.																																																													
	[Setting conditions]																																																													
1	TCNT0=GRA0 when GRA0 functions as an output compare register. TCNT0 value is transferred to GRA0 by an input capture signal when GRA0 functions as an input capture register.																																																													
	[Clearing conditions]	(Initial value)																																																												
0	Read IMFA1 when IMFA1=1, then write 0 in IMFA1 DMAC activated by IMIA1 interrupt.																																																													
	[Setting conditions]																																																													
1	TCNT1=GRA1 when GRA1 functions as an output compare register. TCNT1 value is transferred to GRA1 by an input capture signal when GRA1 functions as an input capture register.																																																													
	[Clearing conditions]	(Initial value)																																																												
0	Read IMFA2 when IMFA2=1, then write 0 in IMFA2 DMAC activated by IMIA2 interrupt.																																																													
	[Setting conditions]																																																													
1	TCNT2=GRA2 when GRA2 functions as an output compare register. TCNT2 value is transferred to GRA2 by an input capture signal when GRA2 functions as an input capture register.																																																													
0	IMIA0 interrupt requested by IMFA0 flag is disabled	(Initial value)																																																												
1	IMIA0 interrupt requested by IMFA0 is enabled																																																													
0	IMIA1 interrupt requested by IMFA1 flag is disabled	(Initial value)																																																												
1	IMIA1 interrupt requested by IMFA1 is enabled																																																													
0	IMIA2 interrupt requested by IMFA2 flag is disabled	(Initial value)																																																												
1	IMIA2 interrupt requested by IMFA2 is enabled																																																													

Note: * Only 0 can be written, to clear the flag.

TISRB—Timer Interrupt Status Register B	H'FFF65	16-bit timer (all channels)
--	----------------	------------------------------------

Bit:	7	6	5	4	3	2	1	0
	—	IMIEB2	IMIEB1	IMIEB0	—	IMFB2	IMFB1	IMFB0
Initial value:	1	0	0	0	1	0	0	0
Read/Write:	—	R/W	R/W	R/W	—	R/(W)*	R/(W)*	R/(W)*

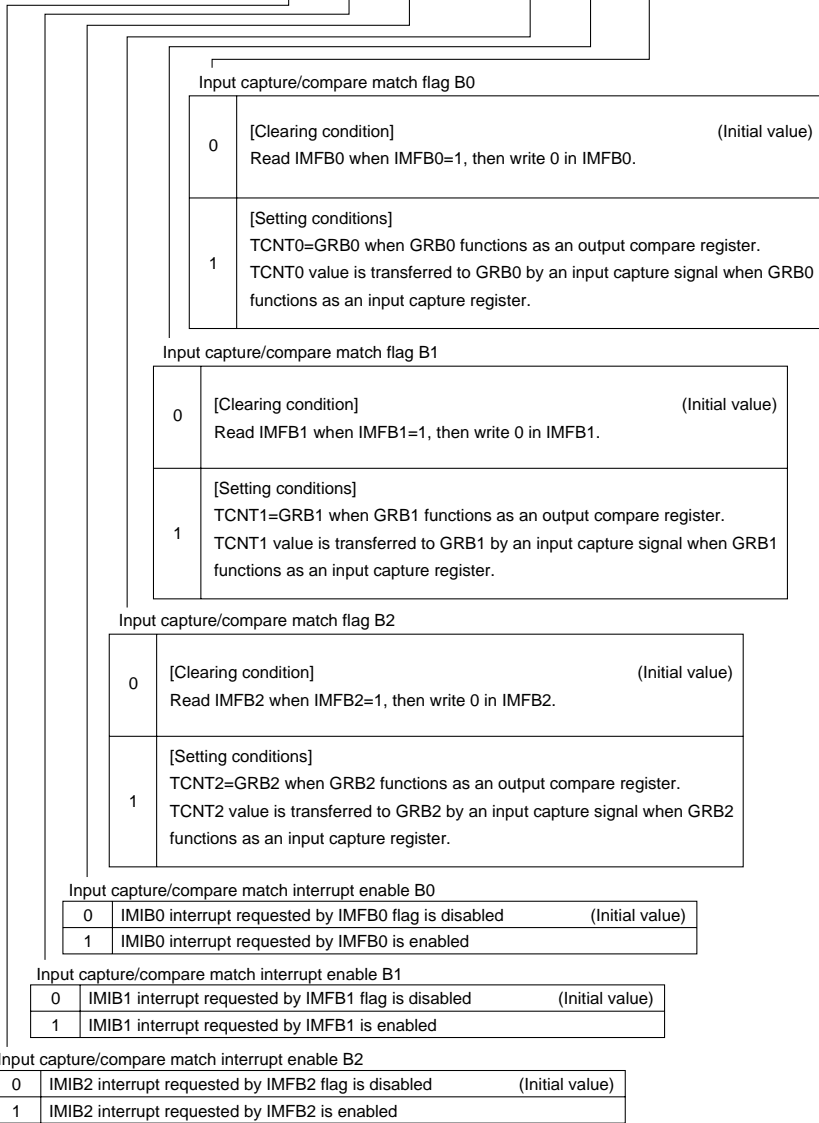

Input capture/compare match flag B0

0	[Clearing condition] Read IMFB0 when IMFB0=1, then write 0 in IMFB0.	(Initial value)
1	[Setting conditions] TCNT0=GRB0 when GRB0 functions as an output compare register. TCNT0 value is transferred to GRB0 by an input capture signal when GRB0 functions as an input capture register.	

Input capture/compare match flag B1

0	[Clearing condition] Read IMFB1 when IMFB1=1, then write 0 in IMFB1.	(Initial value)
1	[Setting conditions] TCNT1=GRB1 when GRB1 functions as an output compare register. TCNT1 value is transferred to GRB1 by an input capture signal when GRB1 functions as an input capture register.	

Input capture/compare match flag B2

0	[Clearing condition] Read IMFB2 when IMFB2=1, then write 0 in IMFB2.	(Initial value)
1	[Setting conditions] TCNT2=GRB2 when GRB2 functions as an output compare register. TCNT2 value is transferred to GRB2 by an input capture signal when GRB2 functions as an input capture register.	

Input capture/compare match interrupt enable B0

0	IMIB0 interrupt requested by IMFB0 flag is disabled	(Initial value)
1	IMIB0 interrupt requested by IMFB0 is enabled	

Input capture/compare match interrupt enable B1

0	IMIB1 interrupt requested by IMFB1 flag is disabled	(Initial value)
1	IMIB1 interrupt requested by IMFB1 is enabled	

Input capture/compare match interrupt enable B2

0	IMIB2 interrupt requested by IMFB2 flag is disabled	(Initial value)
1	IMIB2 interrupt requested by IMFB2 is enabled	

Note: * Only 0 can be written, to clear the flag.



TISRC—Timer Interrupt Status Register C				H'FFF66		16-bit timer (all channels)		
Bit:	7	6	5	4	3	2	1	0
	—	OVIE2	OVIE1	OVIE0	—	OVF2	OVF1	OVF0
Initial value:	1	0	0	0	1	0	0	0
Read/Write:	—	R/W	R/W	R/W	—	R/(W)*	R/(W)*	R/(W)*
Overflow flag 0								
0		[Clearing condition] Read OVF0 when OVF0 = 1, then write 0 in OVF0.					(Initial value)	
1		[Setting condition] TCNT0 overflowed from H'FFFF to H'0000.						
Overflow flag 1								
0		[Clearing condition] Read OVF1 when OVF1 = 1, then write 0 in OVF1.					(Initial value)	
1		[Setting condition] TCNT1 overflowed from H'FFFF to H'0000.						
Overflow flag 2								
0		[Clearing condition] Read OVF2 when OVF2 = 1, then write 0 in OVF2.					(Initial value)	
1		[Setting condition] TCNT2 overflowed from H'FFFF to H'0000, or underflowed from H'0000 to H'FFFF.						
Overflow interrupt enable 0								
0		OVI0 interrupt requested by OVF0 flag is disabled					(Initial value)	
1		OVI0 interrupt requested by OVF0 flag is enabled						
Overflow interrupt enable 1								
0		OVI1 interrupt requested by OVF1 flag is disabled					(Initial value)	
1		OVI1 interrupt requested by OVF1 flag is enabled						
Overflow interrupt enable 2								
0		OVI2 interrupt requested by OVF2 flag is disabled					(Initial value)	
1		OVI2 interrupt requested by OVF2 flag is enabled						
Note: * Only 0 can be written, to clear the flag.								

TCR0—Timer Control Register				H'FFF68		16-bit timer channel 0		
Bit	7	6	5	4	3	2	1	0
	—	CCLR1	CCLR0	CKEG1	CKEG0	TPSC2	TPSC1	TPSC0
Initial value	1	0	0	0	0	0	0	0
Read/Write	—	R/W	R/W	R/W	R/W	R/W	R/W	R/W

Timer prescaler 2 to 0

Bit 2	Bit 1	Bit 0	TCNT Clock Source
TPSC2	TPSC1	TPSC0	
0	0	0	Internal clock : ϕ (Initial value)
		1	Internal clock : $\phi / 2$
	1	0	Internal clock : $\phi / 4$
		1	Internal clock : $\phi / 8$
1	0	0	External clock A : TCLKA input
		1	External clock B : TCLKB input
	1	0	External clock C : TCLKC input
		1	External clock D : TCLKD input

Clock edge 1 and 0

Bit 4	Bit 3	Counted Edges of External Clock
CKEG1	CKEG0	
0	0	Rising edges counted (Initial value)
0	1	Falling edges counted
1	—	Both edges counted

Counter clear 1 and 0

Bit 6	Bit 5	TCNT clear Sources
CCLR1	CCLR0	
0	0	TCNT is not cleared (Initial value)
	1	TCNT is cleared by GRA compare match or input capture
1	0	TCNT is cleared by GRB compare match or input capture
	1	Synchronous clear : TCNT is cleared in synchronization with other synchronized timers

TIOR0—Timer I/O Control Register 0				H'FFF69		16-bit timer channel 0		
Bit:	7	6	5	4	3	2	1	0
	—	IOB2	IOB1	IOB0	—	IOA2	IOA1	IOA0
Initial value:	1	0	0	0	1	0	0	0
Read/Write:	—	R/W	R/W	R/W	—	R/W	R/W	R/W
I/O control A2 to A0								
Bit 2	Bit 1	Bit 0	GRA Functions					
IOA2	IOA1	IOA0						
0	0	0	GRA is an output compare register	No output at compare match (Initial value)				
		1		0 output at GRA compare match				
	1	0		1 output at GRA compare match				
		1		Output toggles at GRA compare match (channel 2 only: 1 output)				
1	0	0	GRA is an input capture register	GRA captures rising edges of input				
		1		GRA captures falling edges of input				
	1	0		GRA captures both edges of input				
		1						
I/O control B2 to B0								
Bit 6	Bit 5	Bit 4	GRB Functions					
IOB2	IOB1	IOB0						
0	0	0	GRB is an output compare register	No output at compare match (Initial value)				
		1		0 output at GRB compare match				
	1	0		1 output at GRB compare match				
		1		Output toggles at GRB compare match (channel 2 only: 1 output)				
1	0	0	GRB is an input capture register	GRB captures rising edges of input				
		1		GRB captures falling edges of input				
	1	0		GRB captures both edges of input				
		1						

TCNT0 H/L—Timer Counter 0 H/L							H'FFF6A, H'FFF6B				16-bit timer channel 0					
Bit	15	14	13	12	11	10	9	8	7	6	5	4	3	2	1	0
Initial value	0	0	0	0	0	0	0	0	0	0	0	0	0	0	0	0
Read/Write	R/W	R/W	R/W	R/W	R/W	R/W	R/W	R/W	R/W	R/W	R/W	R/W	R/W	R/W	R/W	R/W
Up - counter																
GRA0 H/L—General Register A0 H/L							H'FFF6C, H'FFF6D				16-bit timer channel 0					
Bit	15	14	13	12	11	10	9	8	7	6	5	4	3	2	1	0
Initial value	1	1	1	1	1	1	1	1	1	1	1	1	1	1	1	1
Read/Write	R/W	R/W	R/W	R/W	R/W	R/W	R/W	R/W	R/W	R/W	R/W	R/W	R/W	R/W	R/W	R/W
Output compare or input capture register																
GRB0 H/L—General Register B0 H/L							H'FFF6E, H'FFF6F				16-bit timer channel 0					
Bit	15	14	13	12	11	10	9	8	7	6	5	4	3	2	1	0
Initial value	1	1	1	1	1	1	1	1	1	1	1	1	1	1	1	1
Read/Write	R/W	R/W	R/W	R/W	R/W	R/W	R/W	R/W	R/W	R/W	R/W	R/W	R/W	R/W	R/W	R/W
Output compare or input capture register																

TCR1 Timer Control Register 1				H'FFF70				16-bit timer channel 1								
Bit	7	6	5	4	3	2	1	0								
	—	CCLR1	CCLR0	CKEG1	CKEG0	TPSC2	TPSC1	TPSC0								
Initial value	1	0	0	0	0	0	0	0								
Read/Write	—	R/W	R/W	R/W	R/W	R/W	R/W	R/W								
Note: Bit functions are the same as for 16-bit timer channel 0.																
TIOR1—Timer I/O Control Register 1				H'FFF71				16-bit timer channel 1								
Bit	7	6	5	4	3	2	1	0								
	—	IOB2	IOB1	IOB0	—	IOA2	IOA1	IOA0								
Initial value	1	0	0	0	1	0	0	0								
Read/Write	—	R/W	R/W	R/W	—	R/W	R/W	R/W								
Note: Bit functions are the same as for 16-bit timer channel 0.																
TCNT1 H/L—Timer Counter 1 H/L				H'FFF72, H'FFF73				16-bit timer channel 1								
Bit	15	14	13	12	11	10	9	8	7	6	5	4	3	2	1	0
Initial value	0	0	0	0	0	0	0	0	0	0	0	0	0	0	0	0
Read/Write	R/W	R/W	R/W	R/W	R/W	R/W	R/W	R/W	R/W	R/W	R/W	R/W	R/W	R/W	R/W	R/W
Note: Bit functions are the same as for 16-bit timer channel 0.																

GRA1 H/L—General Register A1 H/L										H'FFF74, H'FFF75			16-bit timer channel 1			
Bit	15	14	13	12	11	10	9	8	7	6	5	4	3	2	1	0
Initial value	1	1	1	1	1	1	1	1	1	1	1	1	1	1	1	1
Read/Write	R/W	R/W	R/W	R/W	R/W	R/W	R/W	R/W	R/W	R/W	R/W	R/W	R/W	R/W	R/W	R/W
Note: Bit functions are the same as for 16-bit timer channel 0.																
GRB1 H/L—General Register B1 H/L										H'FFF76, H'FFF77			16-bit timer channel 1			
Bit	15	14	13	12	11	10	9	8	7	6	5	4	3	2	1	0
Initial value	1	1	1	1	1	1	1	1	1	1	1	1	1	1	1	1
Read/Write	R/W	R/W	R/W	R/W	R/W	R/W	R/W	R/W	R/W	R/W	R/W	R/W	R/W	R/W	R/W	R/W
Note: Bit functions are the same as for 16-bit timer channel 0.																
TCR2 Timer Control Register 2								H'FFF78			16-bit timer channel 2					
Bit	7	6	5	4	3	2	1	0								
	—	CCLR1	CCLR0	CKEG1	CKEG0	TPSC2	TPSC1	TPSC0								
Initial value	1	0	0	0	0	0	0	0								
Read/Write	—	R/W	R/W	R/W	R/W	R/W	R/W	R/W								
Notes: 1. Bit functions are the same as for 16-bit timer channel 0. 2. When phase counting mode is selected in channel 2, the settings of bits CKEG1 and CKEG0 and TPSC2 to TPSC0 in TCR2 are ignored.																

TIOR2—Timer I/O Control Register 2				H'FFF79		16-bit timer channel 2										
Bit	7	6	5	4	3	2	1	0								
	—	IOB2	IOB1	IOB0	—	IOA2	IOA1	IOA0								
Initial value	1	0	0	0	1	0	0	0								
Read/Write	—	R/W	R/W	R/W	—	R/W	R/W	R/W								
Note: Bit functions are the same as for 16-bit timer channel 0.																
TCNT2 H/L—Timer Counter 2 H/L				H'FFF7A, H'FFF7B		16-bit timer channel 2										
Bit	15	14	13	12	11	10	9	8	7	6	5	4	3	2	1	0
Initial value	0	0	0	0	0	0	0	0	0	0	0	0	0	0	0	0
Read/Write	R/W	R/W	R/W	R/W	R/W	R/W	R/W	R/W	R/W	R/W	R/W	R/W	R/W	R/W	R/W	R/W
Phase counting mode : up / down counter Other mode : up - counter																
GRA2 H/L—General Register A2 H/L				H'FFF7C, H'FFF7D		16-bit timer channel 2										
Bit	15	14	13	12	11	10	9	8	7	6	5	4	3	2	1	0
Initial value	1	1	1	1	1	1	1	1	1	1	1	1	1	1	1	1
Read/Write	R/W	R/W	R/W	R/W	R/W	R/W	R/W	R/W	R/W	R/W	R/W	R/W	R/W	R/W	R/W	R/W
Note: Bit functions are the same as for 16-bit timer channel 0.																

GRB2 H/L—General Register B2 H/L							H'FFF7E, H'FFF7F				16-bit timer channel 2					
Bit	15	14	13	12	11	10	9	8	7	6	5	4	3	2	1	0
Initial value	1	1	1	1	1	1	1	1	1	1	1	1	1	1	1	1
Read/Write	R/W	R/W	R/W	R/W	R/W	R/W	R/W	R/W	R/W	R/W	R/W	R/W	R/W	R/W	R/W	R/W

Note: Bit functions are the same as for 16-bit timer channel 0.

TCR0—Timer Control Register 0				H'FFF80				8-bit timer channel 0																									
TCR1—Timer Control Register 1				H'FFF81				8-bit timer channel 1																									
Bit	7	6	5	4	3	2	1	0																									
	CMIEB	CMIEA	OVIE	CCLR1	CCLR0	CKS2	CKS1	CKS0																									
Initial value	0	0	0	0	0	0	0	0																									
Read/Write	R/W	R/W	R/W	R/W	R/W	R/W	R/W	R/W																									
									Clock select 2 to 0																								
									<table border="1"> <tr> <td rowspan="4">0</td> <td rowspan="2">0</td> <td>0</td> <td>Clock input is disabled</td> </tr> <tr> <td>1</td> <td>Internal clock, counted on rising edge of $\phi/8$</td> </tr> <tr> <td rowspan="2">1</td> <td>0</td> <td>Internal clock, counted on rising edge of $\phi/64$</td> </tr> <tr> <td>1</td> <td>Internal clock, counted on rising edge of $\phi/8192$</td> </tr> <tr> <td rowspan="4">1</td> <td rowspan="2">0</td> <td>0</td> <td>Channel 0: Count on TCNT1 overflow signal* Channel 1: Count on TCNT0 compare match A*</td> </tr> <tr> <td>1</td> <td>External clock, counted on falling edge</td> </tr> <tr> <td rowspan="2">1</td> <td>0</td> <td>External clock, counted on rising edge</td> </tr> <tr> <td>1</td> <td>External clock, counted on both rising and falling edges</td> </tr> </table>			0	0	0	Clock input is disabled	1	Internal clock, counted on rising edge of $\phi/8$	1	0	Internal clock, counted on rising edge of $\phi/64$	1	Internal clock, counted on rising edge of $\phi/8192$	1	0	0	Channel 0: Count on TCNT1 overflow signal* Channel 1: Count on TCNT0 compare match A*	1	External clock, counted on falling edge	1	0	External clock, counted on rising edge	1	External clock, counted on both rising and falling edges
0	0	0	Clock input is disabled																														
		1	Internal clock, counted on rising edge of $\phi/8$																														
	1	0	Internal clock, counted on rising edge of $\phi/64$																														
		1	Internal clock, counted on rising edge of $\phi/8192$																														
1	0	0	Channel 0: Count on TCNT1 overflow signal* Channel 1: Count on TCNT0 compare match A*																														
		1	External clock, counted on falling edge																														
	1	0	External clock, counted on rising edge																														
		1	External clock, counted on both rising and falling edges																														
									Notes: * If the clock input of channel 0 is the TCNT1 overflow signal and that of channel 1 is the TCNT0 compare match signal, no incrementing clock is generated. Do not use this setting.																								
									Counter clear 1 and 0																								
									<table border="1"> <tr> <td rowspan="2">0</td> <td>0</td> <td>Clearing is disabled</td> </tr> <tr> <td>1</td> <td>Cleared by compare match A</td> </tr> <tr> <td rowspan="2">1</td> <td>0</td> <td>Cleared by compare match B/input capture B</td> </tr> <tr> <td>1</td> <td>Cleared by input capture B</td> </tr> </table>			0	0	Clearing is disabled	1	Cleared by compare match A	1	0	Cleared by compare match B/input capture B	1	Cleared by input capture B												
0	0	Clearing is disabled																															
	1	Cleared by compare match A																															
1	0	Cleared by compare match B/input capture B																															
	1	Cleared by input capture B																															
									Timer overflow interrupt enable																								
									<table border="1"> <tr> <td>0</td> <td>OVI interrupt requested by OVF is disabled</td> </tr> <tr> <td>1</td> <td>OVI interrupt requested by OVF is enabled</td> </tr> </table>			0	OVI interrupt requested by OVF is disabled	1	OVI interrupt requested by OVF is enabled																		
0	OVI interrupt requested by OVF is disabled																																
1	OVI interrupt requested by OVF is enabled																																
									Compare match interrupt enable A																								
									<table border="1"> <tr> <td>0</td> <td>CMIA interrupt requested by CMFA is disabled</td> </tr> <tr> <td>1</td> <td>CMIA interrupt requested by CMFA is enabled</td> </tr> </table>			0	CMIA interrupt requested by CMFA is disabled	1	CMIA interrupt requested by CMFA is enabled																		
0	CMIA interrupt requested by CMFA is disabled																																
1	CMIA interrupt requested by CMFA is enabled																																
									Compare match interrupt enable B																								
									<table border="1"> <tr> <td>0</td> <td>CMIB interrupt requested by CMFB is disabled</td> </tr> <tr> <td>1</td> <td>CMIB interrupt requested by CMFB is enabled</td> </tr> </table>			0	CMIB interrupt requested by CMFB is disabled	1	CMIB interrupt requested by CMFB is enabled																		
0	CMIB interrupt requested by CMFB is disabled																																
1	CMIB interrupt requested by CMFB is enabled																																

TCSR0—Timer Control/Status Register 0				H'FFF82				8-bit timer channel 0				
Bit	7	6	5	4	3	2	1	0				
	CMFB	CMFA	OVF	ADTE	OIS3	OIS2	OS1	OS0				
Initial value	0	0	0	0	0	0	0	0				
Read/Write	R/(W)*	R/(W)*	R/(W)*	R/W	R/W	R/W	R/W	R/W				
									Output select A1 and A0			
									Bit 1	Bit 0	Description	
									OS1	OS0		
									0	0	No change at compare match A	
										1	0	0 output at compare match A
									1	0	1 output at compare match A	
										1	1	Output toggles at compare match A
									Output/input capture edge select B3 and B2			
					ICE in	Bit 3	Bit 2	Description				
					TCSR1	OIS3	OIS2					
					0	0	0	No change at compare match B				
							1	0	0 output at compare match B			
						1	0	1 output at compare match B				
							1	1	Output toggles at compare match B			
					1	0	0	TCORB input capture on rising edge				
							1	1	TCORB input capture on falling edge			
							1	0	TCORB input capture on both rising and falling edges			
									A/D trigger enable (TCSR0 only)			
					TRGE*	Bit 4	Description					
						ADTE						
					0	0	A/D converter start requests by compare match A or an external trigger are disabled					
						1	1	A/D converter start requests by compare match A or an external trigger are enabled				
					1	0	A/D converter start requests by an external trigger are enabled					
						1	1	A/D converter start requests by compare match A are enabled				
					Note: * TRGE is bit 7 of the A/D control register (ADCR).							
					Timer overflow flag							
					0	[Clearing condition] Read OVF when OVF = 1, then write 0 in OVF.						
					1	[Setting condition] TCNT overflows from H'FF to H'00.						
					Compare match flag A							
					0	[Clearing condition] Read CMFA when CMFA = 1, then write 0 in CMFA.						
					1	[Setting condition] TCNT = TCORA						
					Compare match/input capture flag B							
					0	[Clearing condition] Read CMFB when CMFB = 1, then write 0 in CMFB.						
					1	[Setting conditions] TCNT = TCORB The TCNT value is transferred to TCORB by an input capture signal when TCORB functions as an input capture register.						
					Note: * Only 0 can be written to bits 7 to 5, to clear these flags.							

TCSR1—Timer Control/Status Register 1					H'FFF83		8-bit timer channel 1			
Bit	7	6	5	4	3	2	1	0		
	CMFB	CMFA	OVF	ICE	OIS3	OIS2	OS1	OS0		
Initial value	0	0	0	0	0	0	0	0		
Read/Write	R/(W)*	R/(W)*	R/(W)*	R/W	R/W	R/W	R/W	R/W		
						Output select A1 and A0				
						Bit 1	Bit 0	Description		
						OS1	OS0			
						0	0	No change at compare match A		
							1	0	0 output at compare match A	
						1		0	1 output at compare match A	
							1	1	Output toggles at compare match A	
						Output/input capture edge select B3 and B2				
						ICE in TCSR1	Bit 3 OIS3	Bit 2 OIS2	Description	
						0	0	0		No change at compare match B
							1	0	1 output at compare match B	
								1	1	Output toggles at compare match B
							1		0	0
						1		1	1	TCORB input capture on falling edge
								1	0	1
						1	1		1	TCORB input capture on both rising and falling edges
							Input capture enable			
						0	TCORB is a compare match register			
						1	TCORB is an input capture register			
						Timer overflow flag				
						0	[Clearing condition] Read OVF when OVF = 1, then write 0 in OVF.			
						1	[Setting condition] TCNT overflows from H'FF to H'00.			
						Compare match/input capture flag A				
						0	[Clearing condition] Read CMFA when CMFA = 1, then write 0 in CMFA.			
						1	[Setting condition] TCNT = TCORA			
						Compare match/input capture flag B				
						0	[Clearing condition] Read CMFB when CMFB = 1, then write 0 in CMFB.			
						1	[Setting conditions] TCNT = TCORB The TCNT value is transferred to TCORB by an input capture signal when TCORB functions as an input capture register.			

Note: * Only 0 can be written to bits 7 to 5, to clear these flags.

TCORA0—Time Constant Register A0 TCORA1—Time Constant Register A1	H'FFF84 H'FFF85	8-bit timer channel 0 8-bit timer channel 1																																																
<p style="text-align: center;">TCORA0 TCORA1</p> <p style="text-align: center;">Bit 15 14 13 12 11 10 9 8 7 6 5 4 3 2 1 0</p> <table style="width: 100%; border-collapse: collapse;"> <tr> <td style="width: 15px;"></td> <td style="width: 20px; border: 1px solid black;"> </td> <td style="width: 20px; border: 1px solid black;"> </td> <td style="width: 20px; border: 1px solid black;"> </td> <td style="width: 20px; border: 1px solid black;"> </td> <td style="width: 20px; border: 1px solid black;"> </td> <td style="width: 20px; border: 1px solid black;"> </td> <td style="width: 20px; border: 1px solid black;"> </td> <td style="width: 20px; border: 1px solid black;"> </td> <td style="width: 20px; border: 1px solid black;"> </td> <td style="width: 20px; border: 1px solid black;"> </td> <td style="width: 20px; border: 1px solid black;"> </td> <td style="width: 20px; border: 1px solid black;"> </td> <td style="width: 20px; border: 1px solid black;"> </td> <td style="width: 20px; border: 1px solid black;"> </td> <td style="width: 20px; border: 1px solid black;"> </td> </tr> <tr> <td>Initial value</td> <td>1</td><td>1</td><td>1</td><td>1</td><td>1</td><td>1</td><td>1</td><td>1</td><td>1</td><td>1</td><td>1</td><td>1</td><td>1</td><td>1</td><td>1</td> </tr> <tr> <td>Read/Write</td> <td>R/W</td><td>R/W</td><td>R/W</td><td>R/W</td><td>R/W</td><td>R/W</td><td>R/W</td><td>R/W</td><td>R/W</td><td>R/W</td><td>R/W</td><td>R/W</td><td>R/W</td><td>R/W</td><td>R/W</td> </tr> </table>																			Initial value	1	1	1	1	1	1	1	1	1	1	1	1	1	1	1	Read/Write	R/W	R/W	R/W	R/W	R/W	R/W	R/W	R/W	R/W	R/W	R/W	R/W	R/W	R/W	R/W
Initial value	1	1	1	1	1	1	1	1	1	1	1	1	1	1	1																																			
Read/Write	R/W	R/W	R/W	R/W	R/W	R/W	R/W	R/W	R/W	R/W	R/W	R/W	R/W	R/W	R/W																																			
TCORB0—Time Constant Register B0 TCORB1—Time Constant Register B1	H'FFF86 H'FFF87	8-bit timer channel 0 8-bit timer channel 1																																																
<p style="text-align: center;">TCORB0 TCORB1</p> <p style="text-align: center;">Bit 15 14 13 12 11 10 9 8 7 6 5 4 3 2 1 0</p> <table style="width: 100%; border-collapse: collapse;"> <tr> <td style="width: 15px;"></td> <td style="width: 20px; border: 1px solid black;"> </td> <td style="width: 20px; border: 1px solid black;"> </td> <td style="width: 20px; border: 1px solid black;"> </td> <td style="width: 20px; border: 1px solid black;"> </td> <td style="width: 20px; border: 1px solid black;"> </td> <td style="width: 20px; border: 1px solid black;"> </td> <td style="width: 20px; border: 1px solid black;"> </td> <td style="width: 20px; border: 1px solid black;"> </td> <td style="width: 20px; border: 1px solid black;"> </td> <td style="width: 20px; border: 1px solid black;"> </td> <td style="width: 20px; border: 1px solid black;"> </td> <td style="width: 20px; border: 1px solid black;"> </td> <td style="width: 20px; border: 1px solid black;"> </td> <td style="width: 20px; border: 1px solid black;"> </td> <td style="width: 20px; border: 1px solid black;"> </td> </tr> <tr> <td>Initial value</td> <td>1</td><td>1</td><td>1</td><td>1</td><td>1</td><td>1</td><td>1</td><td>1</td><td>1</td><td>1</td><td>1</td><td>1</td><td>1</td><td>1</td><td>1</td> </tr> <tr> <td>Read/Write</td> <td>R/W</td><td>R/W</td><td>R/W</td><td>R/W</td><td>R/W</td><td>R/W</td><td>R/W</td><td>R/W</td><td>R/W</td><td>R/W</td><td>R/W</td><td>R/W</td><td>R/W</td><td>R/W</td><td>R/W</td> </tr> </table>																			Initial value	1	1	1	1	1	1	1	1	1	1	1	1	1	1	1	Read/Write	R/W	R/W	R/W	R/W	R/W	R/W	R/W	R/W	R/W	R/W	R/W	R/W	R/W	R/W	R/W
Initial value	1	1	1	1	1	1	1	1	1	1	1	1	1	1	1																																			
Read/Write	R/W	R/W	R/W	R/W	R/W	R/W	R/W	R/W	R/W	R/W	R/W	R/W	R/W	R/W	R/W																																			
TCNT0—Timer Counter 0 TCNT1—Timer Counter 1	H'FFF88 H'FFF89	8-bit timer channel 0 8-bit timer channel 1																																																
<p style="text-align: center;">TCNT0 TCNT1</p> <p style="text-align: center;">Bit 15 14 13 12 11 10 9 8 7 6 5 4 3 2 1 0</p> <table style="width: 100%; border-collapse: collapse;"> <tr> <td style="width: 15px;"></td> <td style="width: 20px; border: 1px solid black;"> </td> <td style="width: 20px; border: 1px solid black;"> </td> <td style="width: 20px; border: 1px solid black;"> </td> <td style="width: 20px; border: 1px solid black;"> </td> <td style="width: 20px; border: 1px solid black;"> </td> <td style="width: 20px; border: 1px solid black;"> </td> <td style="width: 20px; border: 1px solid black;"> </td> <td style="width: 20px; border: 1px solid black;"> </td> <td style="width: 20px; border: 1px solid black;"> </td> <td style="width: 20px; border: 1px solid black;"> </td> <td style="width: 20px; border: 1px solid black;"> </td> <td style="width: 20px; border: 1px solid black;"> </td> <td style="width: 20px; border: 1px solid black;"> </td> <td style="width: 20px; border: 1px solid black;"> </td> <td style="width: 20px; border: 1px solid black;"> </td> </tr> <tr> <td>Initial value</td> <td>0</td><td>0</td><td>0</td><td>0</td><td>0</td><td>0</td><td>0</td><td>0</td><td>0</td><td>0</td><td>0</td><td>0</td><td>0</td><td>0</td><td>0</td> </tr> <tr> <td>Read/Write</td> <td>R/W</td><td>R/W</td><td>R/W</td><td>R/W</td><td>R/W</td><td>R/W</td><td>R/W</td><td>R/W</td><td>R/W</td><td>R/W</td><td>R/W</td><td>R/W</td><td>R/W</td><td>R/W</td><td>R/W</td> </tr> </table>																			Initial value	0	0	0	0	0	0	0	0	0	0	0	0	0	0	0	Read/Write	R/W	R/W	R/W	R/W	R/W	R/W	R/W	R/W	R/W	R/W	R/W	R/W	R/W	R/W	R/W
Initial value	0	0	0	0	0	0	0	0	0	0	0	0	0	0	0																																			
Read/Write	R/W	R/W	R/W	R/W	R/W	R/W	R/W	R/W	R/W	R/W	R/W	R/W	R/W	R/W	R/W																																			

TCSR—Timer Control/Status Register						H'FFF8C	WDT	
Bit	7	6	5	4	3	2	1	0
	OVF	WT/IT	TME	—	—	CKS2	CKS1	CKS0
Initial value	0	0	0	1	1	0	0	0
Read/Write	R/(W)*	R/W	R/W	—	—	R/W	R/W	R/W

Clock select 2 to 0			
CKS2	CKS1	CKS0	Description
0	0	0	$\phi/2$
		1	$\phi/32$
	1	0	$\phi/64$
		1	$\phi/128$
1	0	0	$\phi/256$
		1	$\phi/512$
	1	0	$\phi/2048$
		1	$\phi/4096$

Timer enable	
0	Timer disabled • TCNT is initialized to H'00 and halted
1	Timer enabled • TCNT is counting

Timer mode select	
0	Interval timer: requests interval timer interrupts
1	Watchdog timer: generates a reset signal

Overflow flag	
0	[Clearing condition] Read OVF when OVF = 1, then write 0 in OVF
1	[Setting condition] TCNT changes from H'FF to H'00

Note: * Only 0 can be written, to clear the flag.

TCNT—Timer Counter				H'FFF8D (read), H'FFF8C (write)				WDT
Bit	7	6	5	4	3	2	1	0
Initial value	0	0	0	0	0	0	0	0
Read/Write	R/W	R/W	R/W	R/W	R/W	R/W	R/W	R/W
				Count value				

RSTCSR—Reset Control/Status Register				H'FFF8F (read), H'FFF8E (write)				WDT
Bit	7	6	5	4	3	2	1	0
	WRST	RSTOE	—	—	—	—	—	—
Initial value	0	0	1	1	1	1	1	1
Read/Write	R/(W)*	R/W	—	—	—	—	—	—
				Reset output enable				
				0		External output of reset signal is disabled		
				1		External output of reset signal is enabled		
				Watchdog timer reset				
				0		[Clearing conditions] Reset signal at RES pin Read WRST when WRST = 1, then write 0 in WRST		
				1		[Setting condition] TCNT overflow generates a reset signal		
Note: * Only 0 can be written in bit 7, to clear the flag.								

TCR2—Timer Control Register 2		H'FFF90		8-bit timer channel 2					
TCR3—Timer Control Register 3		H'FFF91		8-bit timer channel 3					
Bit	7	6	5	4	3	2	1	0	
	CMIEB	CMIEA	OVIE	CCLR1	CCLR0	CKS2	CKS1	CKS0	
Initial value	0	0	0	0	0	0	0	0	
Read/Write	R/W	R/W	R/W	R/W	R/W	R/W	R/W	R/W	
						Clock select 2 to 0			
						CKS2	CKS1	CKS0	Description
						0	0	0	Clock input is disabled
								1	Internal clock, counted on rising edge of $\phi/8$
							1	0	Internal clock, counted on rising edge of $\phi/64$
								1	Internal clock, counted on rising edge of $\phi/8192$
						1	0	0	Channel 2: Count on TCNT3 overflow signal* Channel 3: Count on TCNT2 compare match A*
								1	External clock, counted on falling edge
							1	0	External clock, counted on rising edge
								1	External clock, counted on both rising and falling edges
						Counter clear 1 and 0			
					0	0	Clearing is disabled		
							1	Cleared by compare match A	
					1	0	Cleared by compare match B/input capture B		
							1	Cleared by input capture B	
						Timer overflow interrupt enable			
					0	OVI interrupt requested by OVF is disabled			
					1	OVI interrupt requested by OVF is enabled			
						Compare match interrupt enable A			
					0	CMIA interrupt requested by CMFA is disabled			
					1	CMIA interrupt requested by CMFA is enabled			
						Compare match interrupt enable B			
					0	CMIB interrupt requested by CMFB is disabled			
					1	CMIB interrupt requested by CMFB is enabled			

Note: * If the clock input of channel 2 is the TCNT3 overflow signal and that of channel 3 is the TCNT2 compare match signal, no incrementing clock is generated. Do not use this setting.

TCSR2—Timer Control/Status Register 2	H'FFF92	8-bit timer channel 2
TCSR3—Timer Control/Status Register 3	H'FFF93	8-bit timer channel 3

TCSR2	Bit	7	6	5	4	3	2	1	0
		CMFB	CMFA	OVF	—	OIS3	OIS2	OS1	OS0
Initial value		0	0	0	1	0	0	0	0
Read/Write		R/(W)*	R/(W)*	R/(W)*	—	R/W	R/W	R/W	R/W
TCSR3	Bit	7	6	5	4	3	2	1	0
		CMFB	CMFA	OVF	ICE	OIS3	OIS2	OS1	OS0
Initial value		0	0	0	0	0	0	0	0
Read/Write		R/(W)*	R/(W)*	R/(W)*	R/W	R/W	R/W	R/W	R/W

Output select A1 and A0

Bit 1	Bit 0	Description
0	0	No change at compare match A
	1	0 output at compare match A
1	0	1 output at compare match A
	1	Output toggles at compare match A

Output/input capture edge select B3 and B2

ICE in TCSR3	Bit 3 OIS3	Bit 2 OIS2	Description
0	0	0	No change at compare match B
		1	0 output at compare match B
	1	0	1 output at compare match B
		1	Output toggles at compare match B
1	0	0	TCORB input capture on rising edge
		1	TCORB input capture on falling edge
	1	0	TCORB input capture on both rising and falling edges

Input capture enable (TCSR3 only)

0	TCORB is a compare match register
1	TCORB is an input capture register

Timer overflow flag

0	[Clearing condition] Read OVF when OVF = 1, then write 0 in OVF.
1	[Setting condition] TCNT overflows from H'FF to H'00.

Compare match/input capture flag A

0	[Clearing condition] Read CMFA when CMFA = 1, then write 0 in CMFA.
1	[Setting condition] TCNT = TCORA

Compare match/input capture flag B

0	[Clearing condition] Read CMFB when CMFB = 1, then write 0 in CMFB.
1	[Setting conditions] TCNT = TCORB The TCNT value is transferred to TCORB by an input capture signal when TCORB functions as an input capture register.

Note: * Only 0 can be written to bits 7 to 5, to clear these flags.

TCORA2—Time Constant Register A2 TCORA3—Time Constant Register A3	H'FFF94 H'FFF95	8-bit timer channel 2 8-bit timer channel 3																	
<p style="text-align: center;">TCORA2 TCORA3</p> <p>Bit 15 14 13 12 11 10 9 8 7 6 5 4 3 2 1 0</p> <table style="width: 100%; border-collapse: collapse;"> <tr> <td style="width: 15px;"></td> <td style="width: 20px; border: 1px solid black;"></td> <td style="width: 20px; border: 1px solid black;"></td> <td style="width: 20px; border: 1px solid black;"></td> <td style="width: 20px; border: 1px solid black;"></td> <td style="width: 20px; border: 1px solid black;"></td> <td style="width: 20px; border: 1px solid black;"></td> <td style="width: 20px; border: 1px solid black;"></td> <td style="width: 20px; border: 1px solid black;"></td> <td style="width: 20px; border: 1px solid black;"></td> <td style="width: 20px; border: 1px solid black;"></td> <td style="width: 20px; border: 1px solid black;"></td> <td style="width: 20px; border: 1px solid black;"></td> <td style="width: 20px; border: 1px solid black;"></td> <td style="width: 20px; border: 1px solid black;"></td> <td style="width: 20px; border: 1px solid black;"></td> <td style="width: 20px; border: 1px solid black;"></td> </tr> </table> <p>Initial value 1 1 1 1 1 1 1 1 1 1 1 1 1 1 1 1 1</p> <p>Read/Write R/W R/W R/W R/W R/W R/W R/W R/W R/W R/W R/W R/W R/W R/W R/W R/W R/W</p>																			
TCORB2—Time Constant Register B2 TCORB3—Time Constant Register B3	H'FFF96 H'FFF97	8-bit timer channel 2 8-bit timer channel 3																	
<p style="text-align: center;">TCORB2 TCORB3</p> <p>Bit 15 14 13 12 11 10 9 8 7 6 5 4 3 2 1 0</p> <table style="width: 100%; border-collapse: collapse;"> <tr> <td style="width: 15px;"></td> <td style="width: 20px; border: 1px solid black;"></td> <td style="width: 20px; border: 1px solid black;"></td> <td style="width: 20px; border: 1px solid black;"></td> <td style="width: 20px; border: 1px solid black;"></td> <td style="width: 20px; border: 1px solid black;"></td> <td style="width: 20px; border: 1px solid black;"></td> <td style="width: 20px; border: 1px solid black;"></td> <td style="width: 20px; border: 1px solid black;"></td> <td style="width: 20px; border: 1px solid black;"></td> <td style="width: 20px; border: 1px solid black;"></td> <td style="width: 20px; border: 1px solid black;"></td> <td style="width: 20px; border: 1px solid black;"></td> <td style="width: 20px; border: 1px solid black;"></td> <td style="width: 20px; border: 1px solid black;"></td> <td style="width: 20px; border: 1px solid black;"></td> <td style="width: 20px; border: 1px solid black;"></td> </tr> </table> <p>Initial value 1 1 1 1 1 1 1 1 1 1 1 1 1 1 1 1 1</p> <p>Read/Write R/W R/W R/W R/W R/W R/W R/W R/W R/W R/W R/W R/W R/W R/W R/W R/W R/W</p>																			
TCNT2—Timer Counter 2 TCNT3—Timer Counter 3	H'FFF98 H'FFF99	8-bit timer channel 2 8-bit timer channel 3																	
<p style="text-align: center;">TCNT2 TCNT3</p> <p>Bit 15 14 13 12 11 10 9 8 7 6 5 4 3 2 1 0</p> <table style="width: 100%; border-collapse: collapse;"> <tr> <td style="width: 15px;"></td> <td style="width: 20px; border: 1px solid black;"></td> <td style="width: 20px; border: 1px solid black;"></td> <td style="width: 20px; border: 1px solid black;"></td> <td style="width: 20px; border: 1px solid black;"></td> <td style="width: 20px; border: 1px solid black;"></td> <td style="width: 20px; border: 1px solid black;"></td> <td style="width: 20px; border: 1px solid black;"></td> <td style="width: 20px; border: 1px solid black;"></td> <td style="width: 20px; border: 1px solid black;"></td> <td style="width: 20px; border: 1px solid black;"></td> <td style="width: 20px; border: 1px solid black;"></td> <td style="width: 20px; border: 1px solid black;"></td> <td style="width: 20px; border: 1px solid black;"></td> <td style="width: 20px; border: 1px solid black;"></td> <td style="width: 20px; border: 1px solid black;"></td> <td style="width: 20px; border: 1px solid black;"></td> </tr> </table> <p>Initial value 0 0 0 0 0 0 0 0 0 0 0 0 0 0 0 0 0</p> <p>Read/Write R/W R/W R/W R/W R/W R/W R/W R/W R/W R/W R/W R/W R/W R/W R/W R/W R/W</p>																			

DADR0—D/A Data Register 0					H'FFF9C	D/A		
Bit	7	6	5	4	3	2	1	0
Initial value	0	0	0	0	0	0	0	0
Read/Write	R/W	R/W	R/W	R/W	R/W	R/W	R/W	R/W
 D/A conversion data								
DADR1—D/A Data Register 1					H'FFF9D	D/A		
Bit	7	6	5	4	3	2	1	0
Initial value	0	0	0	0	0	0	0	0
Read/Write	R/W	R/W	R/W	R/W	R/W	R/W	R/W	R/W
 D/A conversion data								

DACR—D/A Control Register						H'FFF9E	D/A	
Bit	7	6	5	4	3	2	1	0
	DAOE1	DAOE0	DAE	—	—	—	—	—
Initial value	0	0	0	1	1	1	1	1
Read/Write	R/W	R/W	R/W	—	—	—	—	—
			D/A enable					
			Bit 7	Bit 6	Bit 5	Description		
			DAOE1	DAOE0	DAE			
			0	0	—	D/A conversion is disabled in channels 0 and 1		
			0	1	0	D/A conversion is enabled in channel 0 D/A conversion is disabled in channel 1		
			0	1	1	D/A conversion is enabled in channels 0 and 1		
			1	0	0	D/A conversion is disabled in channel 0 D/A conversion is enabled in channel 1		
			1	0	1	D/A conversion is enabled in channels 0 and 1		
			1	1	—	D/A conversion is enabled in channels 0 and 1		
			D/A output enable 0					
			0	DA0 analog output is disabled				
			1	Channel-0 D/A conversion and DA0 analog output are enabled				
			D/A output enable 1					
			0	DA1 analog output is disabled				
			1	Channel-1 D/A conversion and DA1 analog output are enabled				

TPMR—TPC Output Mode Register					H'FFFA0	TPC		
Bit	7	6	5	4	3	2	1	0
	—	—	—	—	G3NOV	G2NOV	G1NOV	G0NOV
Initial value	1	1	1	1	0	0	0	0
Read/Write	—	—	—	—	R/W	R/W	R/W	R/W

Group 0 non-overlap

0	Normal TPC output in group 0. Output values change at compare match A in the selected 16-bit timer channel
1	Non-overlapping TPC output in group 0, controlled by compare match A and B in the selected 16-bit timer channel

Group 1 non-overlap

0	Normal TPC output in group 1. Output values change at compare match A in the selected 16-bit timer channel
1	Non-overlapping TPC output in group 1, controlled by compare match A and B in the selected 16-bit timer channel

Group 2 non-overlap

0	Normal TPC output in group 2. Output values change at compare match A in the selected 16-bit timer channel
1	Non-overlapping TPC output in group 2, controlled by compare match A and B in the selected 16-bit timer channel

Group 3 non-overlap

0	Normal TPC output in group 3. Output values change at compare match A in the selected 16-bit timer channel
1	Non-overlapping TPC output in group 3, controlled by compare match A and B in the selected 16-bit timer channel

TPCR—TPC Output Control Register								H'FFFA1	TPC		
Bit	7	6	5	4	3	2	1	0			
	G3CMS1	G3CMS0	G2CMS1	G2CMS0	G1CMS1	G1CMS0	G0CMS1	G0CMS0			
Initial value	1	1	1	1	1	1	1	1			
Read/Write	R/W	R/W	R/W	R/W	R/W	R/W	R/W	R/W			
								Group 0 compare match select 1 and 0			
								Bit 1	Bit 0	16-Bit Timer Channel Selected as Output Trigger	
								G0CMS1	G0CMS0		
								0	0		TPC output group 0 (TP ₃ to TP ₀) is triggered by compare match in 16-bit timer channel 0
									1		1
								1		0	TPC output group 0 (TP ₃ to TP ₀) is triggered by compare match in 16-bit timer channel 2
									1	1	
								Group 1 compare match select 1 and 0			
								Bit 3	Bit 2	16-Bit Timer Channel Selected as Output Trigger	
								G1CMS1	G1CMS0		
								0	0		TPC output group 1 (TP ₇ to TP ₄) is triggered by compare match in 16-bit timer channel 0
									1		1
								1		0	TPC output group 1 (TP ₇ to TP ₄) is triggered by compare match in 16-bit timer channel 2
									1	1	
								Group 2 compare match select 1 and 0			
								Bit 5	Bit 4	16-Bit Timer Channel Selected as Output Trigger	
								G2CMS1	G2CMS0		
								0	0		TPC output group 2 (TP ₁₁ to TP ₈) is triggered by compare match in 16-bit timer channel 0
									1		1
								1		0	TPC output group 2 (TP ₁₁ to TP ₈) is triggered by compare match in 16-bit timer channel 2
									1	1	
								Group 3 compare match select 1 and 0			
								Bit 7	Bit 6	16-Bit Timer Channel Selected as Output Trigger	
								G3CMS1	G3CMS0		
								0	0		TPC output group 3 (TP ₁₅ to TP ₁₂) is triggered by compare match in 16-bit timer channel 0
									1		1
								1		0	TPC output group 3 (TP ₁₅ to TP ₁₂) is triggered by compare match in 16-bit timer channel 2
									1	1	

NDERB—Next Data Enable Register B					H'FFFA2	TPC		
Bit	7	6	5	4	3	2	1	0
	NDER15	NDER14	NDER13	NDER12	NDER11	NDER10	NDER9	NDER8
Initial value	0	0	0	0	0	0	0	0
Read/Write	R/W	R/W	R/W	R/W	R/W	R/W	R/W	R/W
Next data enable 15 to 8								
Bits 7 to 0		Description						
NDER15 to NDER8								
0		TPC outputs TP15 to TP8 are disabled (NDR15 to NDR8 are not transferred to PB7 to PB0)						
1		TPC outputs TP15 to TP8 are enabled (NDR15 to NDR8 are transferred to PB7 to PB0)						

NDERA—Next Data Enable Register A					H'FFFA3	TPC		
Bit	7	6	5	4	3	2	1	0
	NDER7	NDER6	NDER5	NDER4	NDER3	NDER2	NDER1	NDER0
Initial value	0	0	0	0	0	0	0	0
Read/Write	R/W	R/W	R/W	R/W	R/W	R/W	R/W	R/W
Next data enable 7 to 0								
Bits 7 to 0		Description						
NDER7 to NDER0								
0		TPC outputs TP7 to TP0 are disabled (NDR7 to NDR0 are not transferred to PA7 to PA0)						
1		TPC outputs TP7 to TP0 are enabled (NDR7 to NDR0 are transferred to PA7 to PA0)						

NDRB—Next Data Register B				H'FFFA4/H'FFFA6				TPC
<ul style="list-style-type: none"> Same trigger for TPC output groups 2 and 3 								
— Address H'FFFA4								
Bit	7	6	5	4	3	2	1	0
	NDR15	NDR14	NDR13	NDR12	NDR11	NDR10	NDR9	NDR8
Initial value	0	0	0	0	0	0	0	0
Read/Write	R/W	R/W	R/W	R/W	R/W	R/W	R/W	R/W
				Store the next output data for TPC output group 3				Store the next output data for TPC output group 2
— Address H'FFFA6								
Bit	7	6	5	4	3	2	1	0
	_____	_____	_____	_____	_____	_____	_____	_____
Initial value	1	1	1	1	1	1	1	1
Read/Write	_____	_____	_____	_____	_____	_____	_____	_____
<ul style="list-style-type: none"> Different triggers for TPC output groups 2 and 3 								
— Address H'FFFA4								
Bit	7	6	5	4	3	2	1	0
	NDR15	NDR14	NDR13	NDR12	_____	_____	_____	_____
Initial value	0	0	0	0	1	1	1	1
Read/Write	R/W	R/W	R/W	R/W	_____	_____	_____	_____
				Store the next output data for TPC output group 3				
— Address H'FFFA6								
Bit	7	6	5	4	3	2	1	0
	_____	_____	_____	_____	NDR11	NDR10	NDR9	NDR8
Initial value	1	1	1	1	0	0	0	0
Read/Write	_____	_____	_____	_____	R/W	R/W	R/W	R/W
						Store the next output data for TPC output group 2		

NDRA—Next Data Register A					H'FFFA5/H'FFFA7		TPC	
<ul style="list-style-type: none"> Same trigger for TPC output groups 0 and 1 								
— Address H'FFFA5								
Bit	7	6	5	4	3	2	1	0
	NDR7	NDR6	NDR5	NDR4	NDR3	NDR2	NDR1	NDR0
Initial value	0	0	0	0	0	0	0	0
Read/Write	R/W	R/W	R/W	R/W	R/W	R/W	R/W	R/W
Store the next output data for TPC output group 1					Store the next output data for TPC output group 0			
— Address H'FFFA7								
Bit	7	6	5	4	3	2	1	0
	_____	_____	_____	_____	_____	_____	_____	_____
Initial value	1	1	1	1	1	1	1	1
Read/Write	_____	_____	_____	_____	_____	_____	_____	_____
<ul style="list-style-type: none"> Different triggers for TPC output groups 0 and 1 								
— Address H'FFFA5								
Bit	7	6	5	4	3	2	1	0
	NDR7	NDR6	NDR5	NDR4	_____	_____	_____	_____
Initial value	0	0	0	0	1	1	1	1
Read/Write	R/W	R/W	R/W	R/W	_____	_____	_____	_____
Store the next output data for TPC output group 1								
— Address H'FFFA7								
Bit	7	6	5	4	3	2	1	0
	_____	_____	_____	_____	NDR3	NDR2	NDR1	NDR0
Initial value	1	1	1	1	0	0	0	0
Read/Write	_____	_____	_____	_____	R/W	R/W	R/W	R/W
					Store the next output data for TPC output group 0			

SMR—Serial Mode Register					H'FFFB0		SCIO	
Bit	7	6	5	4	3	2	1	0
	C/ \bar{A}	CHR	PE	O/ \bar{E}	STOP	MP	CKS1	CKS0
Initial value	0	0	0	0	0	0	0	0
Read/Write	R/W	R/W	R/W	R/W	R/W	R/W	R/W	R/W
							Clock select 1 and 0	
							Bit 1	Bit 0
							CKS1	CKS0
							Clock Source	
							0	0
								1
							ϕ clock	
							$\phi/4$ clock	
							1	0
								1
							$\phi/16$ clock	
							$\phi/64$ clock	
							Multiprocessor mode	
							0	Multiprocessor function disabled
							1	Multiprocessor format selected
							Stop bit length	
							0	One stop bit
							1	Two stop bits
							Parity mode	
							0	Even parity
							1	Odd parity
							Parity enable	
							0	Parity bit is not added or checked
							1	Parity bit is added and checked
							Character length	
							0	8-bit data
							1	7-bit data
							Communication mode (for serial communication interface)	
							0	Asynchronous mode
							1	Synchronous mode
							GSM mode (for smart card interface)	
							0	TEND flag is set 12.5 etu* after start bit
							1	TEND flag is set 11.0 etu* after start bit
							Note: * etu (Elementary time unit: the time for transfer of one bit)	

BRR—Bit Rate Register				H'FFFB1		SCIO		
Bit	7	6	5	4	3	2	1	0
Initial value	1	1	1	1	1	1	1	1
Read/Write	R/W	R/W	R/W	R/W	R/W	R/W	R/W	R/W

Serial communication bit rate setting

SCR—Serial Control Register **H'FFFB2** **SCIO**

	7	6	5	4	3	2	1	0																																							
	TIE	RIE	TE	RE	MPIE	TEIE	CKE1	CKE0																																							
Initial value	0	0	0	0	0	0	0	0																																							
Read/Write	R/W	R/W	R/W	R/W	R/W	R/W	R/W	R/W																																							
				<table border="1" style="margin-left: auto; margin-right: auto;"> <tr><th colspan="2">Receive enable</th></tr> <tr><td style="text-align: center;">0</td><td>Receiving is disabled</td></tr> <tr><td style="text-align: center;">1</td><td>Receiving is enabled</td></tr> </table>	Receive enable		0	Receiving is disabled	1	Receiving is enabled			<table border="1" style="margin-left: auto; margin-right: auto;"> <tr><th>Bit 1</th><th>Bit 0</th><th colspan="2">Description</th></tr> <tr><th>CKE1</th><th>CKE0</th><td></td><td></td></tr> <tr><td rowspan="4" style="text-align: center;">0</td><td rowspan="2" style="text-align: center;">0</td><td>Asynchronous mode</td><td>Internal clock, SCK pin available for generic I/O</td></tr> <tr><td>Synchronous mode</td><td>Internal clock, SCK pin used for serial clock output</td></tr> <tr><td rowspan="2" style="text-align: center;">1</td><td>Asynchronous mode</td><td>Internal clock, SCK pin used for clock output</td></tr> <tr><td>Synchronous mode</td><td>Internal clock, SCK pin used for serial clock output</td></tr> <tr><td rowspan="4" style="text-align: center;">1</td><td rowspan="2" style="text-align: center;">0</td><td>Asynchronous mode</td><td>External clock, SCK pin used for serial clock input</td></tr> <tr><td>Synchronous mode</td><td>External clock, SCK pin used for clock input</td></tr> <tr><td rowspan="2" style="text-align: center;">1</td><td>Asynchronous mode</td><td>External clock, SCK pin used for clock input</td></tr> <tr><td>Synchronous mode</td><td>External clock, SCK pin used for serial clock input</td></tr> </table>		Bit 1	Bit 0	Description		CKE1	CKE0			0	0	Asynchronous mode	Internal clock, SCK pin available for generic I/O	Synchronous mode	Internal clock, SCK pin used for serial clock output	1	Asynchronous mode	Internal clock, SCK pin used for clock output	Synchronous mode	Internal clock, SCK pin used for serial clock output	1	0	Asynchronous mode	External clock, SCK pin used for serial clock input	Synchronous mode	External clock, SCK pin used for clock input	1	Asynchronous mode	External clock, SCK pin used for clock input	Synchronous mode	External clock, SCK pin used for serial clock input			
Receive enable																																															
0	Receiving is disabled																																														
1	Receiving is enabled																																														
Bit 1	Bit 0	Description																																													
CKE1	CKE0																																														
0	0	Asynchronous mode	Internal clock, SCK pin available for generic I/O																																												
		Synchronous mode	Internal clock, SCK pin used for serial clock output																																												
	1	Asynchronous mode	Internal clock, SCK pin used for clock output																																												
		Synchronous mode	Internal clock, SCK pin used for serial clock output																																												
1	0	Asynchronous mode	External clock, SCK pin used for serial clock input																																												
		Synchronous mode	External clock, SCK pin used for clock input																																												
	1	Asynchronous mode	External clock, SCK pin used for clock input																																												
		Synchronous mode	External clock, SCK pin used for serial clock input																																												
		<table border="1" style="margin-left: auto; margin-right: auto;"> <tr><th colspan="2">Transmit enable</th></tr> <tr><td style="text-align: center;">0</td><td>Transmitting is disabled</td></tr> <tr><td style="text-align: center;">1</td><td>Transmitting is enabled</td></tr> </table>	Transmit enable		0	Transmitting is disabled	1	Transmitting is enabled				<table border="1" style="margin-left: auto; margin-right: auto;"> <tr><th>SMR</th><th>Bit 1</th><th>Bit 0</th><th colspan="2">Description</th></tr> <tr><th>GM</th><th>CKE1</th><th>CKE0</th><td></td><td></td></tr> <tr><td rowspan="2" style="text-align: center;">0</td><td rowspan="2" style="text-align: center;">0</td><td style="text-align: center;">0</td><td colspan="2">SCK pin available for generic I/O</td></tr> <tr><td style="text-align: center;">1</td><td colspan="2">SCK pin used for clock output</td></tr> <tr><td rowspan="4" style="text-align: center;">1</td><td rowspan="2" style="text-align: center;">0</td><td style="text-align: center;">0</td><td colspan="2">SCK pin output fixed low</td></tr> <tr><td style="text-align: center;">1</td><td colspan="2">SCK pin used for clock output</td></tr> <tr><td rowspan="2" style="text-align: center;">1</td><td style="text-align: center;">0</td><td colspan="2">SCK pin output fixed high</td></tr> <tr><td style="text-align: center;">1</td><td style="text-align: center;">1</td><td colspan="2">SCK pin used for clock output</td></tr> </table>		SMR	Bit 1	Bit 0	Description		GM	CKE1	CKE0			0	0	0	SCK pin available for generic I/O		1	SCK pin used for clock output		1	0	0	SCK pin output fixed low		1	SCK pin used for clock output		1	0	SCK pin output fixed high		1	1	SCK pin used for clock output	
Transmit enable																																															
0	Transmitting is disabled																																														
1	Transmitting is enabled																																														
SMR	Bit 1	Bit 0	Description																																												
GM	CKE1	CKE0																																													
0	0	0	SCK pin available for generic I/O																																												
		1	SCK pin used for clock output																																												
1	0	0	SCK pin output fixed low																																												
		1	SCK pin used for clock output																																												
	1	0	SCK pin output fixed high																																												
		1	1	SCK pin used for clock output																																											
								<table border="1" style="margin-left: auto; margin-right: auto;"> <tr><th colspan="2">Transmit-end interrupt enable</th></tr> <tr><td style="text-align: center;">0</td><td>Transmit-end interrupt requests (TEI) are disabled</td></tr> <tr><td style="text-align: center;">1</td><td>Transmit-end interrupt requests (TEI) are enabled</td></tr> </table>	Transmit-end interrupt enable		0	Transmit-end interrupt requests (TEI) are disabled	1	Transmit-end interrupt requests (TEI) are enabled																																	
Transmit-end interrupt enable																																															
0	Transmit-end interrupt requests (TEI) are disabled																																														
1	Transmit-end interrupt requests (TEI) are enabled																																														
								<table border="1" style="margin-left: auto; margin-right: auto;"> <tr><th colspan="2">Multiprocessor interrupt enable</th></tr> <tr><td style="text-align: center;">0</td><td>Multiprocessor interrupts are disabled (normal receive operation)</td></tr> <tr><td style="text-align: center;">1</td><td>Multiprocessor interrupts are enabled</td></tr> </table>	Multiprocessor interrupt enable		0	Multiprocessor interrupts are disabled (normal receive operation)	1	Multiprocessor interrupts are enabled																																	
Multiprocessor interrupt enable																																															
0	Multiprocessor interrupts are disabled (normal receive operation)																																														
1	Multiprocessor interrupts are enabled																																														
								<table border="1" style="margin-left: auto; margin-right: auto;"> <tr><th colspan="2">Receive interrupt enable</th></tr> <tr><td style="text-align: center;">0</td><td>Receive-data-full (RXI) and receive-error (ERI) interrupt requests are disabled</td></tr> <tr><td style="text-align: center;">1</td><td>Receive-data-full (RXI) and receive-error (ERI) interrupt requests are enabled</td></tr> </table>	Receive interrupt enable		0	Receive-data-full (RXI) and receive-error (ERI) interrupt requests are disabled	1	Receive-data-full (RXI) and receive-error (ERI) interrupt requests are enabled																																	
Receive interrupt enable																																															
0	Receive-data-full (RXI) and receive-error (ERI) interrupt requests are disabled																																														
1	Receive-data-full (RXI) and receive-error (ERI) interrupt requests are enabled																																														
								<table border="1" style="margin-left: auto; margin-right: auto;"> <tr><th colspan="2">Transmit interrupt enable</th></tr> <tr><td style="text-align: center;">0</td><td>Transmit-data-empty interrupt request (TXI) is disabled</td></tr> <tr><td style="text-align: center;">1</td><td>Transmit-data-empty interrupt request (TXI) is enabled</td></tr> </table>	Transmit interrupt enable		0	Transmit-data-empty interrupt request (TXI) is disabled	1	Transmit-data-empty interrupt request (TXI) is enabled																																	
Transmit interrupt enable																																															
0	Transmit-data-empty interrupt request (TXI) is disabled																																														
1	Transmit-data-empty interrupt request (TXI) is enabled																																														

TDR—Transmit Data Register					H'FFFB3	SCIO		
Bit	7	6	5	4	3	2	1	0
Initial value	1	1	1	1	1	1	1	1
Read/Write	R/W	R/W	R/W	R/W	R/W	R/W	R/W	R/W
	Serial transmit data							

SSR—Serial Status Register							H'FFFB4	SCIO
Bit	7	6	5	4	3	2	1	0
	TDRE	RDRF	ORER	FER/ERS	PER	TEND	MPB	MPBT
Initial value	1	0	0	0	0	0	0	0
Read/Write	R/(W)*	R/(W)*	R/(W)*	R/(W)*	R/(W)*	R	R	R/W
							Multiprocessor bit transfer	
							0	Multiprocessor bit value in transmit data is 0
							1	Multiprocessor bit value in transmit data is 1
							Multiprocessor bit	
							0	Multiprocessor bit value in receive data is 0
							1	Multiprocessor bit value in receive data is 1
						Transmit end (for serial communication interface)		
						0	[Clearing conditions] Read TDRE when TDRE = 1, then write 0 in TDRE. The DMAC writes data in TDR.	
						1	[Setting conditions] Reset or transition to standby mode TE is cleared to 0 in SCR. TDRE is 1 when last bit of 1-byte serial character is transmitted.	
						Transmit end (for smart card interface)		
						0	[Clearing conditions] Read TDRE when TDRE = 1, then write 0 in TDRE. The DMAC writes data in TDR.	
						1	[Setting conditions] Reset or transition to standby mode TE is cleared to 0 in SCR and FER/ERS is cleared to 0. TDRE is 1 and FER/ERS is 0 (normal transmission) 2.5 etu* (when GM = 0) or 1.0 etu (when GM = 1) after 1-byte serial character is transmitted.	
						Note: * etu (Elementary time unit: the time for transfer of one bit)		
				Parity error				
				0	[Clearing conditions] Reset or transition to standby mode Read PER when PER = 1, then write 0 in PER.			
				1	[Setting condition] Parity error (parity of receive data does not match parity setting of O/E bit in SMR)			
			Framing error (for serial communication interface)					
			0	[Clearing conditions] Reset or transition to standby mode Read FER when FER = 1, then write 0 in FER.				
			1	[Setting condition] Framing error (stop bit is 0)				
			Error signal status (for smart card interface)					
			0	[Clearing conditions] Reset or transition to standby mode Read ERS when ERS = 1, then write 0 in ERS.				
			1	[Setting condition] A low error signal is received.				
		Overrun error						
		0	[Clearing conditions] Reset or transition to standby mode Read ORER when ORER = 1, then write 0 in ORER.					
		1	[Setting condition] Overrun error (reception of the next serial data ends when RDRF = 1)					
		Receive data register full						
		0	[Clearing conditions] Reset or transition to standby mode Read RDRF when RDRF = 1, then write 0 in RDRF. The DMAC reads data from RDR.					
		1	[Setting condition] Serial data is received normally and transferred from RSR to RDR.					
		Transmit data register empty						
		0	[Clearing conditions] Read TDRE when TDRE = 1, then write 0 in TDRE. The DMAC writes data in TDR.					
		1	[Setting conditions] Reset or transition to standby mode TE is 0 in SCR. Data is transferred from TDR to TSR, enabling new data to be written in TDR					

Note: * Only 0 can be written, to clear the flag.

RDR—Receive Data Register				H'FFFB5	SCIO			
Bit	7	6	5	4	3	2	1	0
Initial value	0	0	0	0	0	0	0	0
Read/Write	R	R	R	R	R	R	R	R
Serial receive data								

SCMR—Smart Card Mode Register				H'FFFB6	SCIO															
Bit	7	6	5	4	3	2	1	0												
	—	—	—	—	SDIR	SINV	—	SMIF												
Initial value	1	1	1	1	0	0	1	0												
Read/Write	—	—	—	—	R/W	R/W	—	R/W												
Smart card interface mode select																				
<table border="1"> <tr> <td>0</td> <td>Smart card interface function is disabled</td> <td>(Initial value)</td> </tr> <tr> <td>1</td> <td>Smart card interface function is enabled</td> <td></td> </tr> </table>									0	Smart card interface function is disabled	(Initial value)	1	Smart card interface function is enabled							
0	Smart card interface function is disabled	(Initial value)																		
1	Smart card interface function is enabled																			
Smart card data invert																				
<table border="1"> <tr> <td>0</td> <td>Unmodified TDR contents are transmitted</td> <td>(Initial value)</td> </tr> <tr> <td></td> <td>Receive data is stored unmodified in RDR</td> <td></td> </tr> <tr> <td>1</td> <td>Inverted 1/0 logic levels of TDR contents are transmitted</td> <td></td> </tr> <tr> <td></td> <td>1/0 logic levels of received data are inverted before storage in RDR</td> <td></td> </tr> </table>									0	Unmodified TDR contents are transmitted	(Initial value)		Receive data is stored unmodified in RDR		1	Inverted 1/0 logic levels of TDR contents are transmitted			1/0 logic levels of received data are inverted before storage in RDR	
0	Unmodified TDR contents are transmitted	(Initial value)																		
	Receive data is stored unmodified in RDR																			
1	Inverted 1/0 logic levels of TDR contents are transmitted																			
	1/0 logic levels of received data are inverted before storage in RDR																			
Smart card data transfer direction																				
<table border="1"> <tr> <td>0</td> <td>TDR contents are transmitted LSB-first</td> <td>(Initial value)</td> </tr> <tr> <td></td> <td>Receive data is stored LSB-first in RDR</td> <td></td> </tr> <tr> <td>1</td> <td>TDR contents are transmitted MSB-first</td> <td></td> </tr> <tr> <td></td> <td>Receive data is stored MSB-first in RDR</td> <td></td> </tr> </table>									0	TDR contents are transmitted LSB-first	(Initial value)		Receive data is stored LSB-first in RDR		1	TDR contents are transmitted MSB-first			Receive data is stored MSB-first in RDR	
0	TDR contents are transmitted LSB-first	(Initial value)																		
	Receive data is stored LSB-first in RDR																			
1	TDR contents are transmitted MSB-first																			
	Receive data is stored MSB-first in RDR																			

SMR—Serial Mode Register						H'FFFB8	SCI1	
Bit	7	6	5	4	3	2	1	0
	C \bar{A}	CHR	PE	O \bar{E}	STOP	MP	CKS1	CKS0
Initial value	0	0	0	0	0	0	0	0
Read/Write	R/W	R/W	R/W	R/W	R/W	R/W	R/W	R/W
Note: Bit functions are the same as for SCI0.								

BRR—Bit Rate Register						H'FFFB9	SCI1	
Bit	7	6	5	4	3	2	1	0
Initial value	1	1	1	1	1	1	1	1
Read/Write	R/W	R/W	R/W	R/W	R/W	R/W	R/W	R/W
Note: Bit functions are the same as for SCI0.								

SCR—Serial Control Register						H'FFBFA	SCI1	
Bit	7	6	5	4	3	2	1	0
	TIE	RIE	TE	RE	MPIE	TEIE	CKE1	CKE0
Initial value	0	0	0	0	0	0	0	0
Read/Write	R/W	R/W	R/W	R/W	R/W	R/W	R/W	R/W
Note: Bit functions are the same as for SCI0.								

TDR—Transmit Data Register					H'FFFBB	SCI1		
Bit	7	6	5	4	3	2	1	0
Initial value	1	1	1	1	1	1	1	1
Read/Write	R/W	R/W	R/W	R/W	R/W	R/W	R/W	R/W
Note: Bit functions are the same as for SCI0.								

SSR—Serial Status Register					H'FFFBC	SCI1		
Bit	7	6	5	4	3	2	1	0
	TDRE	RDRF	ORER	FER/ERS	PER	TEND	MPB	MPBT
Initial value	0	0	0	0	0	1	0	0
Read/Write	R/(W)*	R/(W)*	R/(W)*	R/(W)*	R/(W)*	R	R	R/W
Note: Bit functions are the same as for SCI0.								
* Only 0 can be written, to clear the flag.								

RDR—Receive Data Register					H'FFFBD	SCI1		
Bit	7	6	5	4	3	2	1	0
Initial value	0	0	0	0	0	0	0	0
Read/Write	R	R	R	R	R	R	R	R
Note: Bit functions are the same as for SCI0.								

SCMR—Smart Card Mode Register					H'FFFBE	SCI1		
Bit	7	6	5	4	3	2	1	0
	_____	_____	_____	_____	SDIR	SINV	_____	SMIF
Initial value	1	1	1	1	0	0	1	0
Read/Write	_____	_____	_____	_____	R/W	R/W	_____	R/W
Note: Bit functions are the same as for SCI0.								

SMR—Serial Mode Register					H'FFFC0	SCI2		
Bit	7	6	5	4	3	2	1	0
	C \bar{A}	CHR	PE	O \bar{E}	STOP	MP	CKS1	CKS0
Initial value	0	0	0	0	0	0	0	0
Read/Write	R/W	R/W	R/W	R/W	R/W	R/W	R/W	R/W
Note: Bit functions are the same as for SCI0.								

BRR—Bit Rate Register					H'FFFC1	SCI2		
Bit	7	6	5	4	3	2	1	0
	_____	_____	_____	_____	_____	_____	_____	_____
Initial value	1	1	1	1	1	1	1	1
Read/Write	R/W	R/W	R/W	R/W	R/W	R/W	R/W	R/W
Note: Bit functions are the same as for SCI0.								

SCR—Serial Control Register					H'FFFC2	SCI2		
Bit	7	6	5	4	3	2	1	0
	TIE	RIE	TE	RE	MPIE	TEIE	CKE1	CKE0
Initial value	0	0	0	0	0	0	0	0
Read/Write	R/W	R/W	R/W	R/W	R/W	R/W	R/W	R/W
Note: Bit functions are the same as for SCI0.								
TDR—Transmit Data Register					H'FFFC3	SCI2		
Bit	7	6	5	4	3	2	1	0
Initial value	1	1	1	1	1	1	1	1
Read/Write	R/W	R/W	R/W	R/W	R/W	R/W	R/W	R/W
Note: Bit functions are the same as for SCI0.								
SSR—Serial Status Register					H'FFFC4	SCI2		
Bit	7	6	5	4	3	2	1	0
	TDRE	RDRF	ORER	FER/ERS	PER	TEND	MPB	MPBT
Initial value	1	0	0	0	0	1	0	0
Read/Write	R/(W)*	R/(W)*	R/(W)*	R/(W)*	R/(W)*	R	R	R/W
Note: Bit functions are the same as for SCI0.								
* Only 0 can be written, to clear the flag.								

RDR—Receive Data Register					H'FFFC5	SCI2		
Bit	7	6	5	4	3	2	1	0
Initial value	0	0	0	0	0	0	0	0
Read/Write	R	R	R	R	R	R	R	R
Note: Bit functions are the same as for SCI0.								
SCMR—Smart Card Mode Register					H'FFFC6	SCI2		
Bit	7	6	5	4	3	2	1	0
					SDIR	SINV		SMIF
Initial value	1	1	1	1	0	0	1	0
Read/Write					R/W	R/W		R/W
Note: Bit functions are the same as for SCI0.								
P1DR—Port 1 Data Register					H'FFFD0	Port 1		
Bit	7	6	5	4	3	2	1	0
	P17	P16	P15	P14	P13	P12	P11	P10
Initial value	0	0	0	0	0	0	0	0
Read/Write	R/W	R/W	R/W	R/W	R/W	R/W	R/W	R/W
Data for port 1 pins								

P2DR—Port 2 Data Register					H'FFFD1	Port 2		
Bit	7	6	5	4	3	2	1	0
	P27	P26	P25	P24	P23	P22	P21	P20
Initial value	0	0	0	0	0	0	0	0
Read/Write	R/W	R/W	R/W	R/W	R/W	R/W	R/W	R/W
Data for port 2 pins								
P3DR—Port 3 Data Register					H'FFFD2	Port 3		
Bit	7	6	5	4	3	2	1	0
	P37	P36	P35	P34	P33	P32	P31	P30
Initial value	0	0	0	0	0	0	0	0
Read/Write	R/W	R/W	R/W	R/W	R/W	R/W	R/W	R/W
Data for port 3 pins								
P4DR—Port 4 Data Register					H'FFFD3	Port 4		
Bit	7	6	5	4	3	2	1	0
	P47	P46	P45	P44	P43	P42	P41	P40
Initial value	0	0	0	0	0	0	0	0
Read/Write	R/W	R/W	R/W	R/W	R/W	R/W	R/W	R/W
Data for port 4 pins								

P5DR—Port 5 Data Register					H'FFFD4	Port 5		
Bit	7	6	5	4	3	2	1	0
	_____	_____	_____	_____	P5 ₃	P5 ₂	P5 ₁	P5 ₀
Initial value	1	1	1	1	0	0	0	0
Read/Write	_____	_____	_____	_____	R/W	R/W	R/W	R/W
Data for port 5 pins								
P6DR—Port 6 Data Register					H'FFFD5	Port 6		
Bit	7	6	5	4	3	2	1	0
	P6 ₇	P6 ₆	P6 ₅	P6 ₄	P6 ₃	P6 ₂	P6 ₁	P6 ₀
Initial value	1	0	0	0	0	0	0	0
Read/Write	R	R/W	R/W	R/W	R/W	R/W	R/W	R/W
Data for port 6 pins								
P7DR—Port 7 Data Register					H'FFFD6	Port 7		
Bit	7	6	5	4	3	2	1	0
	P7 ₇	P7 ₆	P7 ₅	P7 ₄	P7 ₃	P7 ₂	P7 ₁	P7 ₀
Initial value	_____ *	_____ *	_____ *	_____ *	_____ *	_____ *	_____ *	_____ *
Read/Write	R	R	R	R	R	R	R	R
Data for port 7 pins								
Note: * Determined by pins P7 ₇ to P7 ₀ .								

P8DR—Port 8 Data Register				H'FFFD7				Port 8
Bit	7	6	5	4	3	2	1	0
	—	—	—	P84	P83	P82	P81	P80
Initial value	1	1	1	0	0	0	0	0
Read/Write	—	—	—	R/W	R/W	R/W	R/W	R/W
				Data for port 8 pins				

P9DR—Port 9 Data Register				H'FFFD8				Port 9
Bit	7	6	5	4	3	2	1	0
	—	—	P95	P94	P93	P92	P91	P90
Initial value	1	1	0	0	0	0	0	0
Read/Write	—	—	R/W	R/W	R/W	R/W	R/W	R/W
				Data for port 9 pins				

PADR—Port A Data Register				H'FFFD9				Port A
Bit	7	6	5	4	3	2	1	0
	PA7	PA6	PA5	PA4	PA3	PA2	PA1	PA0
Initial value	0	0	0	0	0	0	0	0
Read/Write	R/W	R/W	R/W	R/W	R/W	R/W	R/W	R/W
				Data for port A pins				

PBDR—Port B Data Register					H'FFFDA		Port B	
Bit	7	6	5	4	3	2	1	0
	PB7	PB6	PB5	PB4	PB3	PB2	PB1	PB0
Initial value	0	0	0	0	0	0	0	0
Read/Write	R/W	R/W	R/W	R/W	R/W	R/W	R/W	R/W
Data for port B pins								

ADDRA H/L—A/D Data Register A H/L					H'FFFE0, H'FFFE1		A/D									
Bit	15	14	13	12	11	10	9	8	7	6	5	4	3	2	1	0
	AD9	AD8	AD7	AD6	AD5	AD4	AD3	AD2	AD1	AD0	—	—	—	—	—	—
Initial value	0	0	0	0	0	0	0	0	0	0	0	0	0	0	0	0
Read/Write	R	R	R	R	R	R	R	R	R	R	R	R	R	R	R	R
ADDRAH										ADDRAL						
A/D conversion data 10-bit data giving an A/D conversion result																

ADDRB H/L—A/D Data Register B H/L					H'FFFE2, H'FFFE3		A/D									
Bit	15	14	13	12	11	10	9	8	7	6	5	4	3	2	1	0
	AD9	AD8	AD7	AD6	AD5	AD4	AD3	AD2	AD1	AD0	—	—	—	—	—	—
Initial value	0	0	0	0	0	0	0	0	0	0	0	0	0	0	0	0
Read/Write	R	R	R	R	R	R	R	R	R	R	R	R	R	R	R	R
ADDRBH										ADDRBL						
A/D conversion data 10-bit data giving an A/D conversion result																

ADDRC H/L—A/D Data Register C H/L											H'FFFE4, H'FFFE5					A/D		
Bit	15	14	13	12	11	10	9	8	7	6	5	4	3	2	1	0		
	AD9	AD8	AD7	AD6	AD5	AD4	AD3	AD2	AD1	AD0	—	—	—	—	—	—		
Initial value	0	0	0	0	0	0	0	0	0	0	0	0	0	0	0	0		
Read/Write	R	R	R	R	R	R	R	R	R	R	R	R	R	R	R	R		
	ADDRCH										ADDRCL							
<p>A/D conversion data 10-bit data giving an A/D conversion result</p>																		
ADDRD H/L—A/D Data Register D H/L											H'FFFE6, H'FFFE7					A/D		
Bit	15	14	13	12	11	10	9	8	7	6	5	4	3	2	1	0		
	AD9	AD8	AD7	AD6	AD5	AD4	AD3	AD2	AD1	AD0	—	—	—	—	—	—		
Initial value	0	0	0	0	0	0	0	0	0	0	0	0	0	0	0	0		
Read/Write	R	R	R	R	R	R	R	R	R	R	R	R	R	R	R	R		
	ADDRDH										ADDRDL							
<p>A/D conversion data 10-bit data giving an A/D conversion result</p>																		
ADCR—A/D Control Register											H'FFFE9					A/D		
Bit	7		6		5		4		3		2		1		0			
	TRGE		—		—		—		—		—		—		—			
Initial value	0		1		1		1		1		1		1		0			
Read/Write	R/W		—		—		—		—		—		—		R/W			
	Trigger Enable																	
	0		A/D conversion start by external trigger or 8-bit timer compare match is disabled															
	1		A/D conversion is started by falling edge of external trigger signal (ADTRG) or 8-bit timer compare match															

Appendix C I/O Port Block Diagrams

C.1 Port 1 Block Diagram

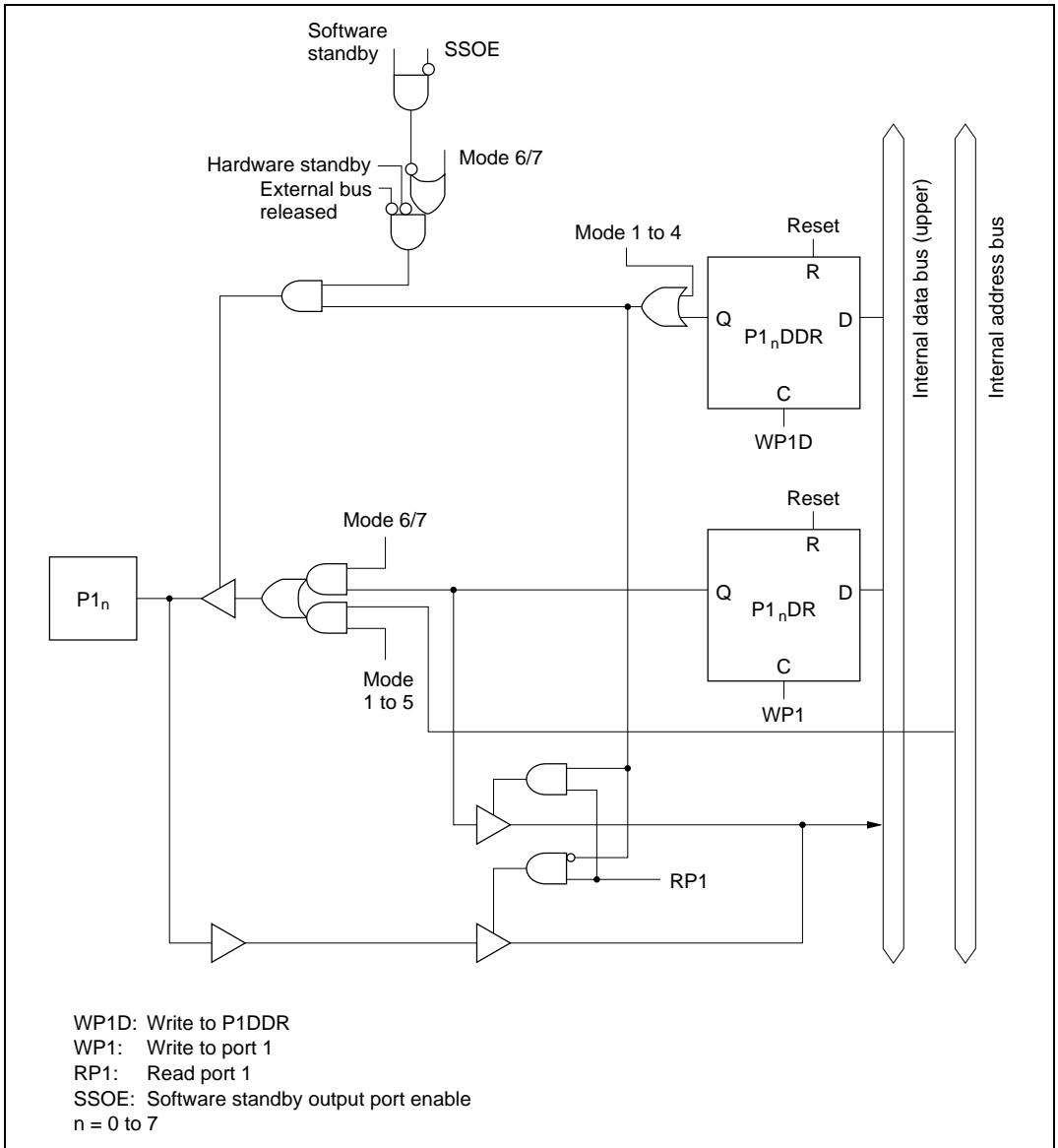

Figure C.1 Port 1 Block Diagram

C.2 Port 2 Block Diagram

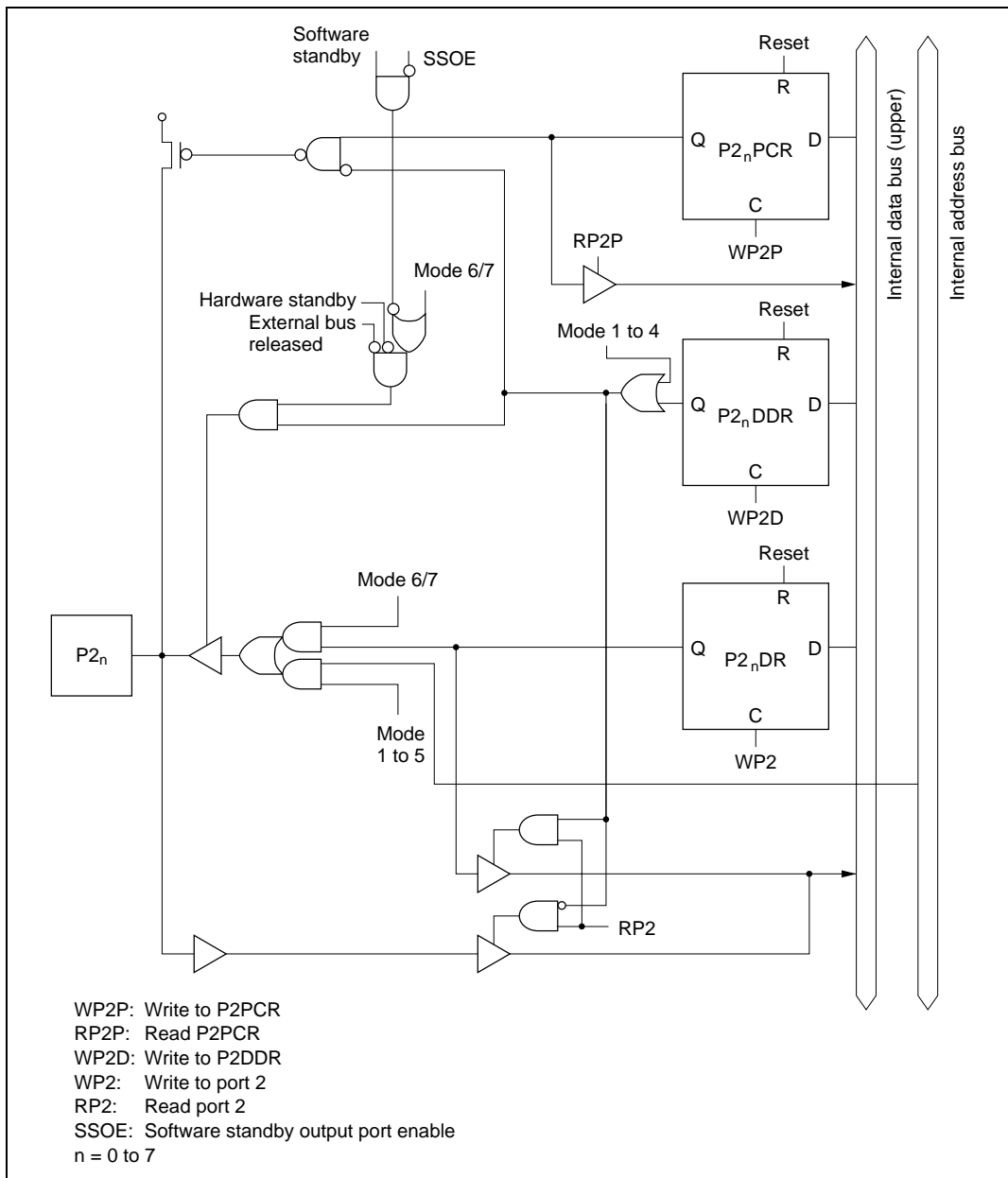

Figure C.2 Port 2 Block Diagram

C.3 Port 3 Block Diagram

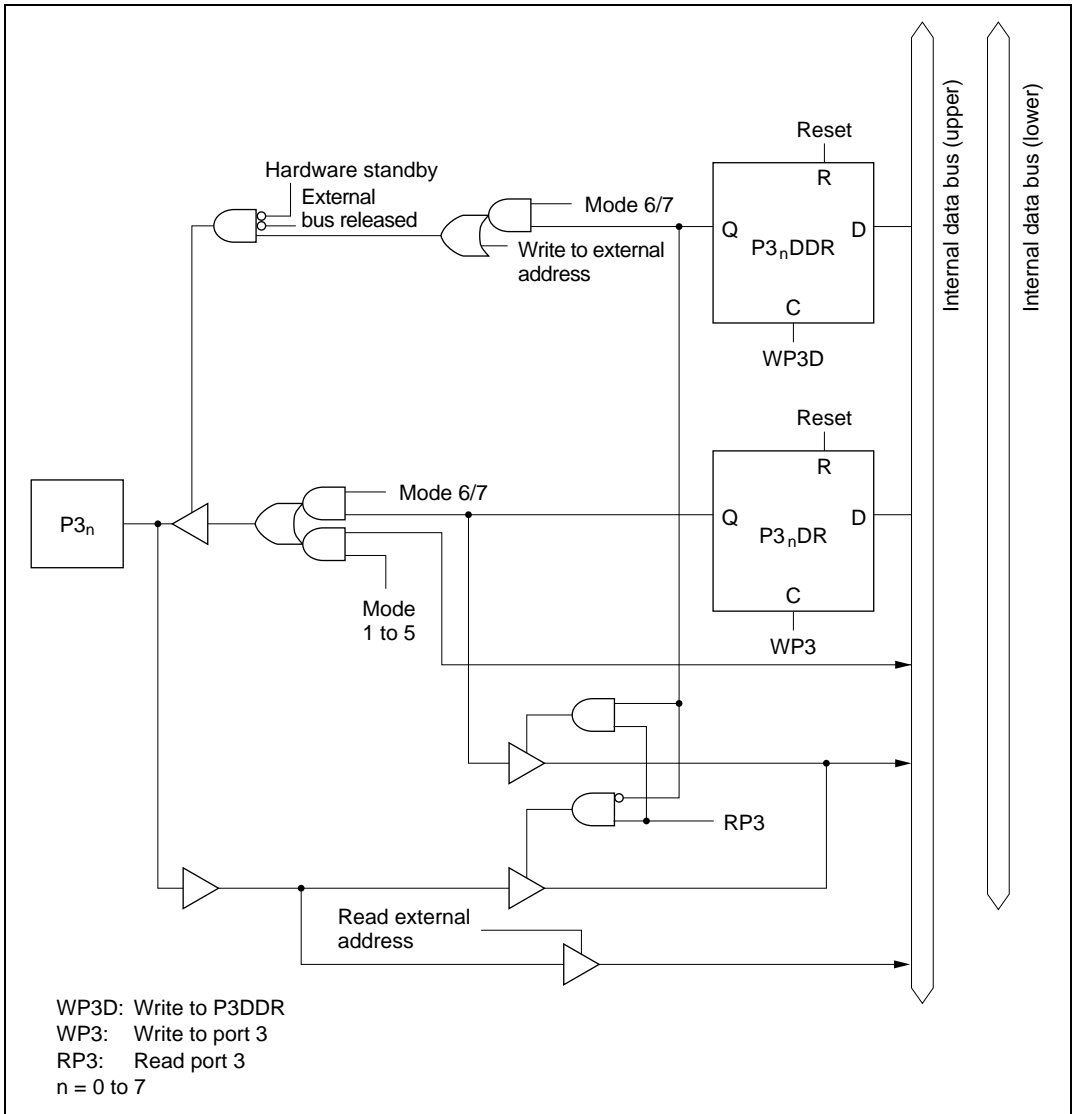

Figure C.3 Port 3 Block Diagram

C.4 Port 4 Block Diagram

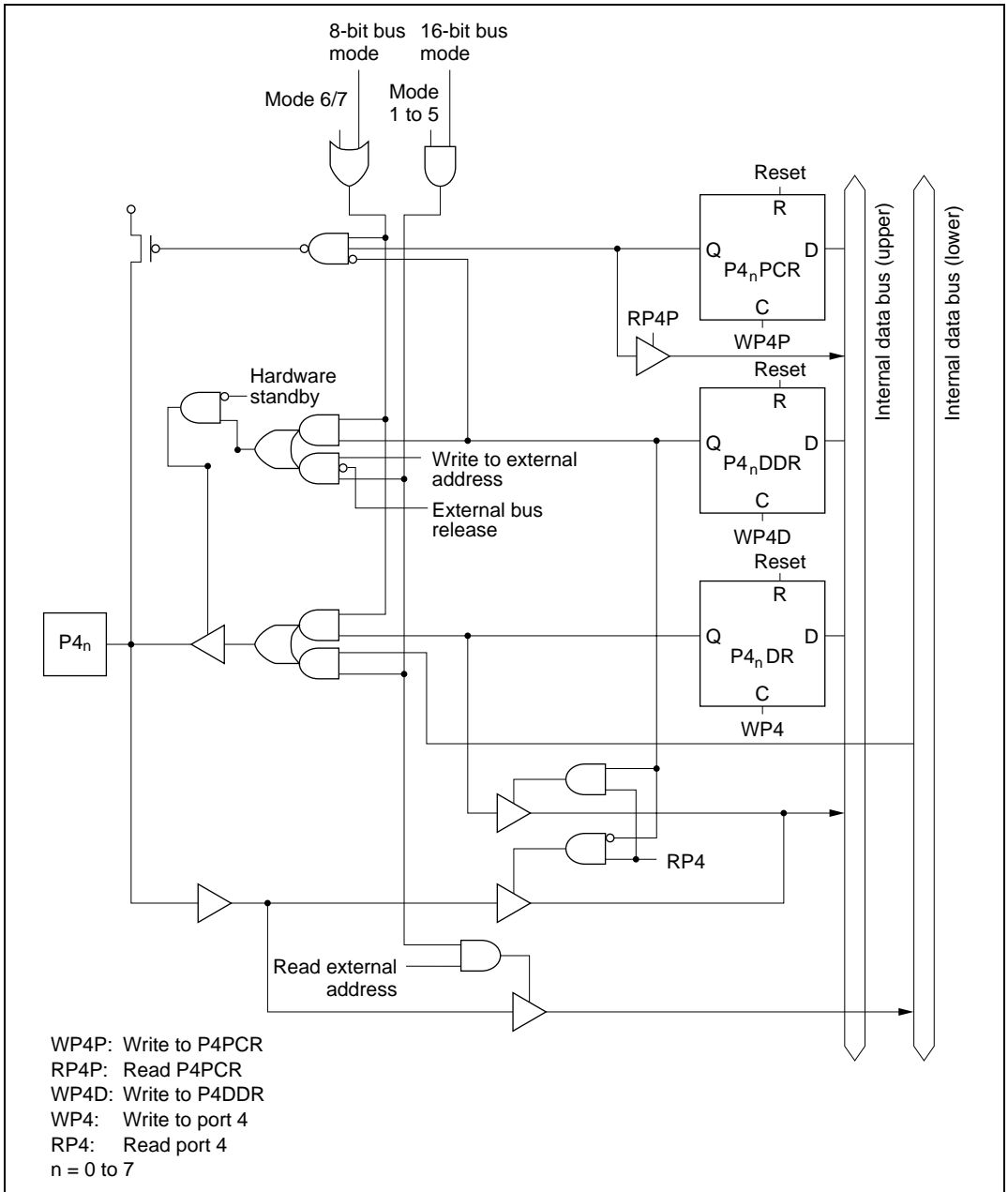

Figure C.4 Port 4 Block Diagram

C.6 Port 6 Block Diagrams

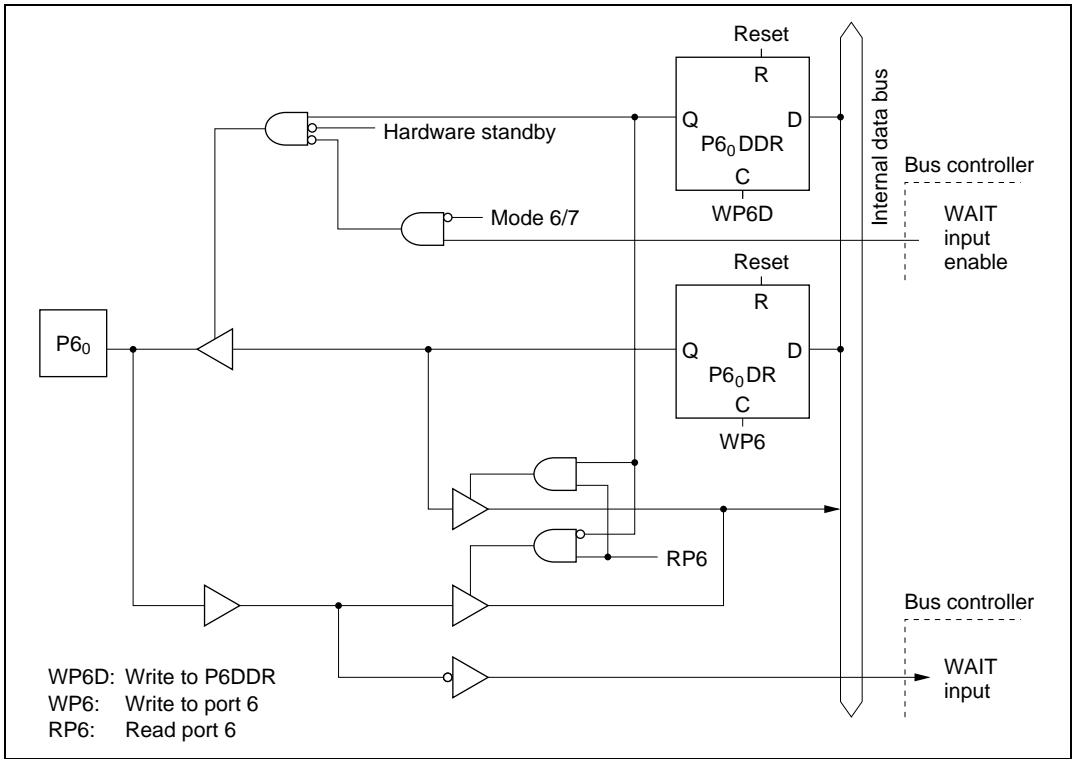

Figure C.6 (a) Port 6 Block Diagram (Pin P60)

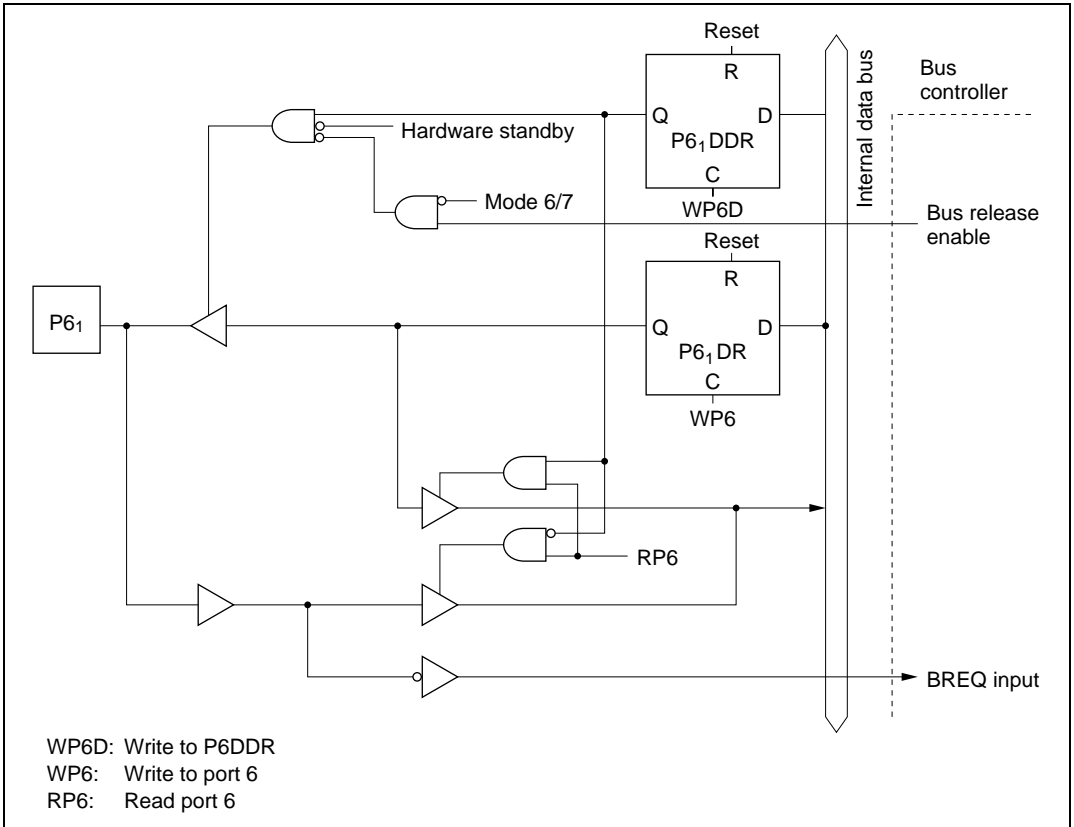

Figure C.6 (b) Port 6 Block Diagram (Pin P6₁)

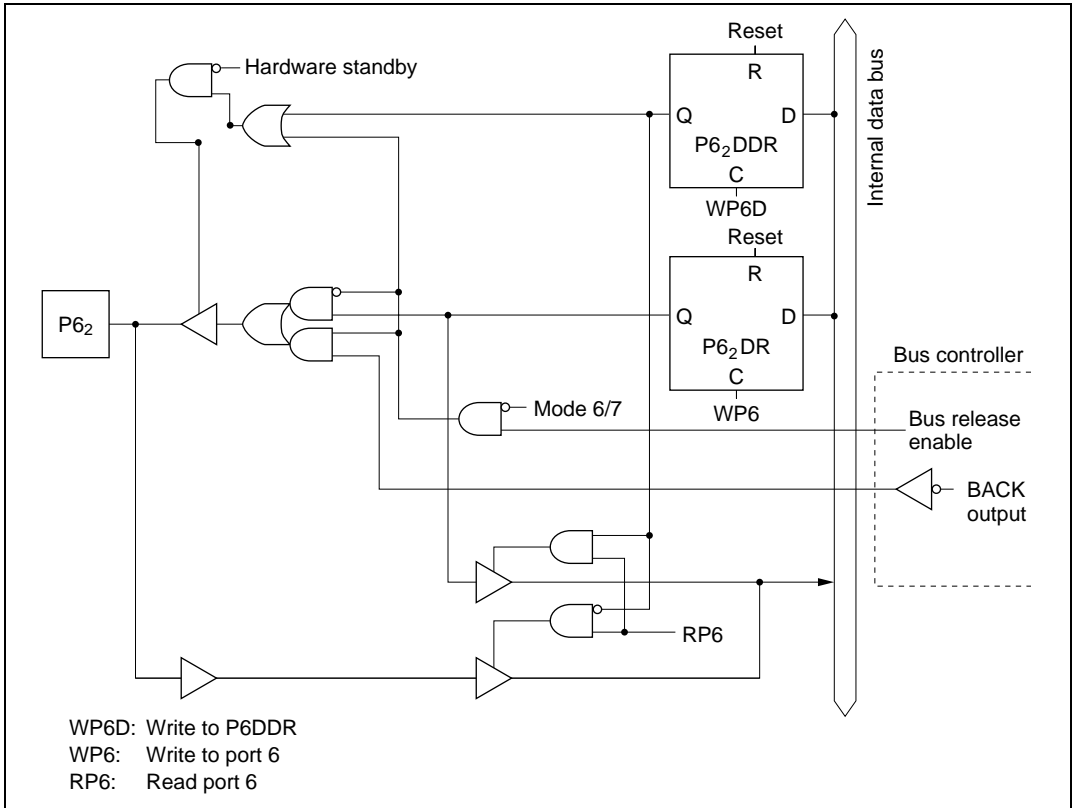

Figure C.6 (c) Port 6 Block Diagram (Pin P6₂)

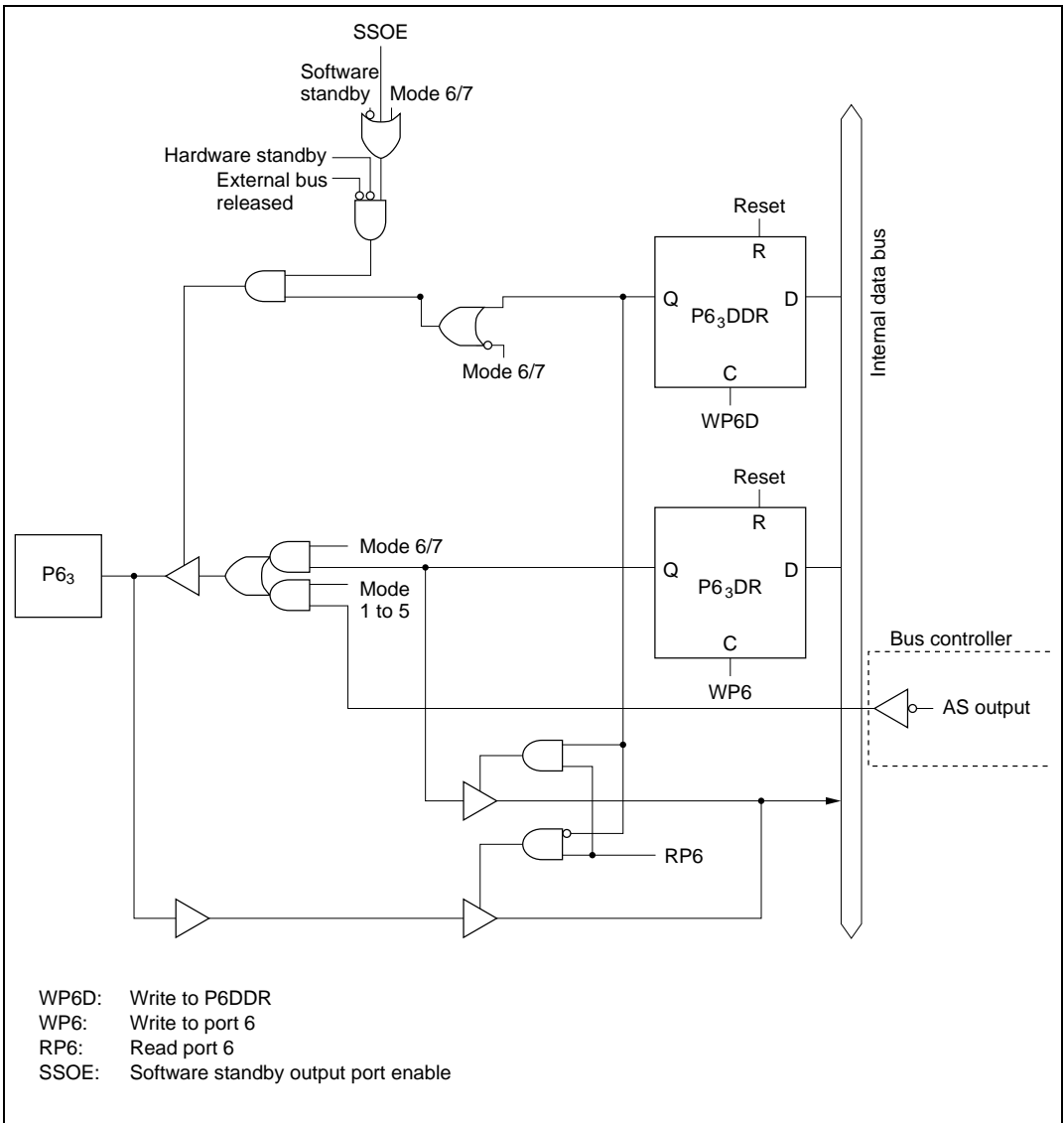

Figure C.6 (d) Port 6 Block Diagram (Pin P6₃)

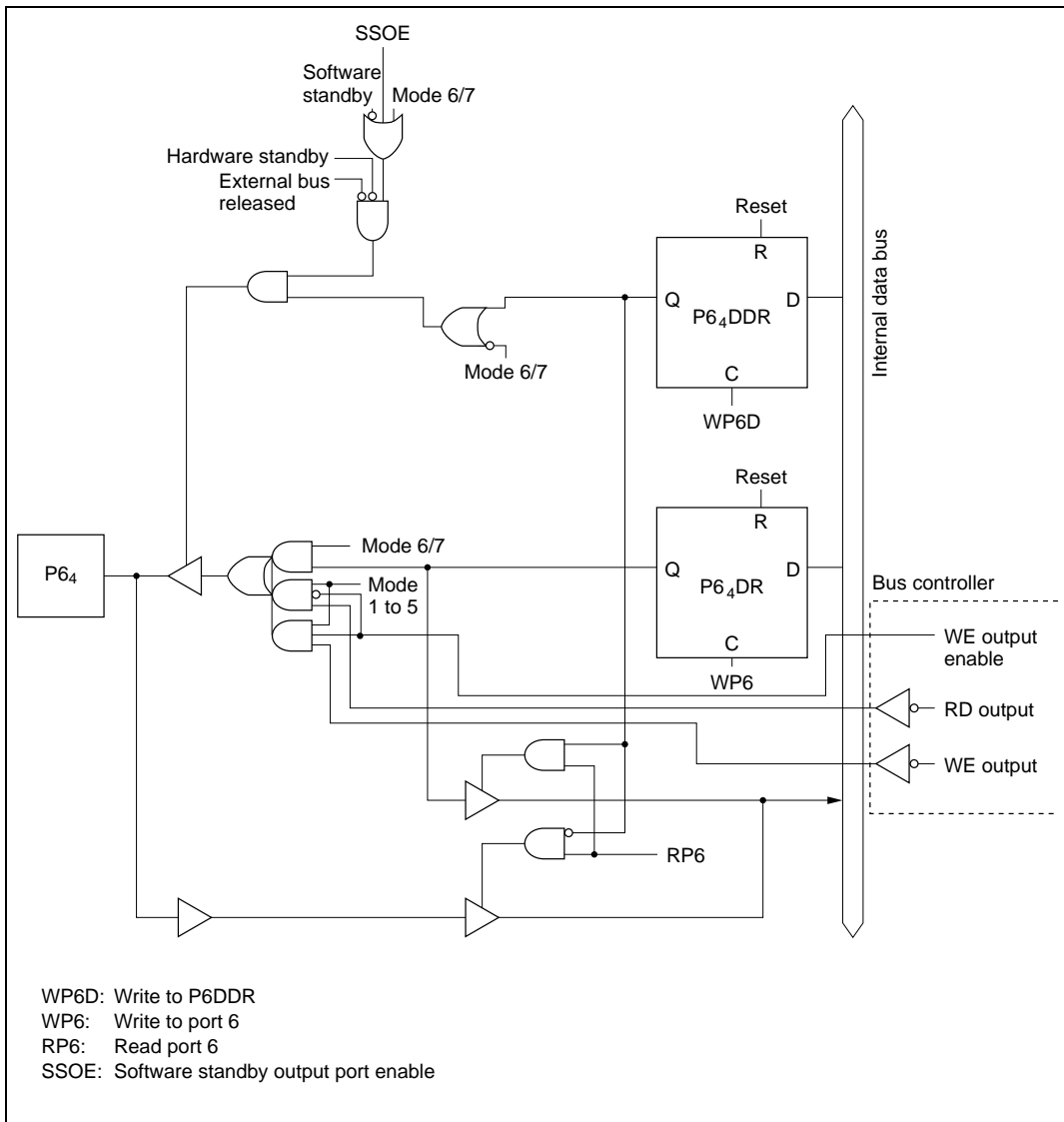

Figure C.6 (e) Port 6 Block Diagram (Pin P64)

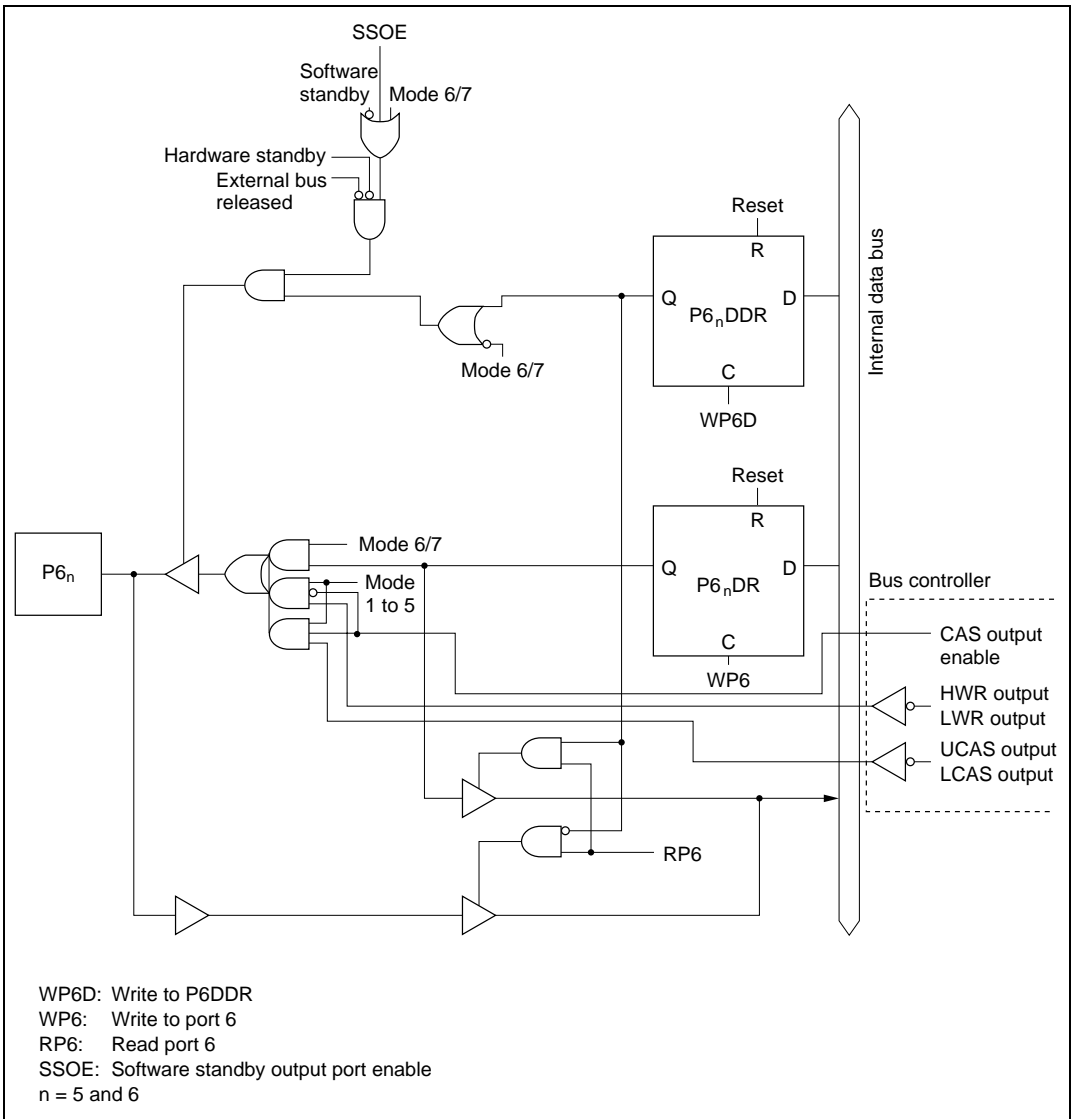
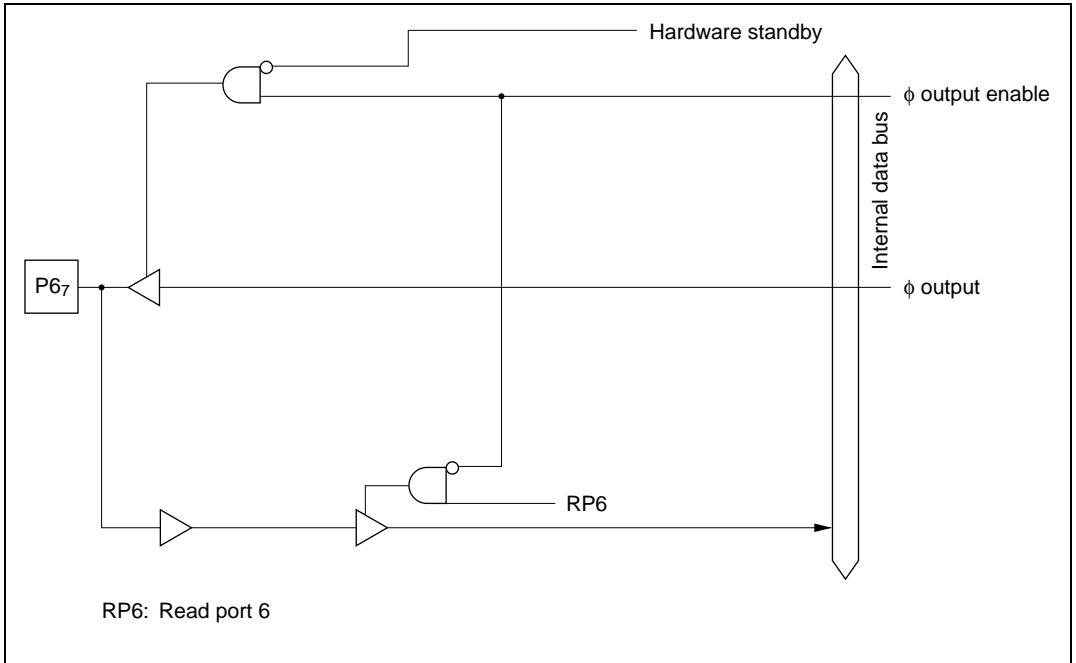

Figure C.6 (f) Port 6 Block Diagram (Pins P6₅ and P6₆)

**Figure C.6 (g) Port 6 Block Diagram (Pin P67)**

C.7 Port 7 Block Diagrams

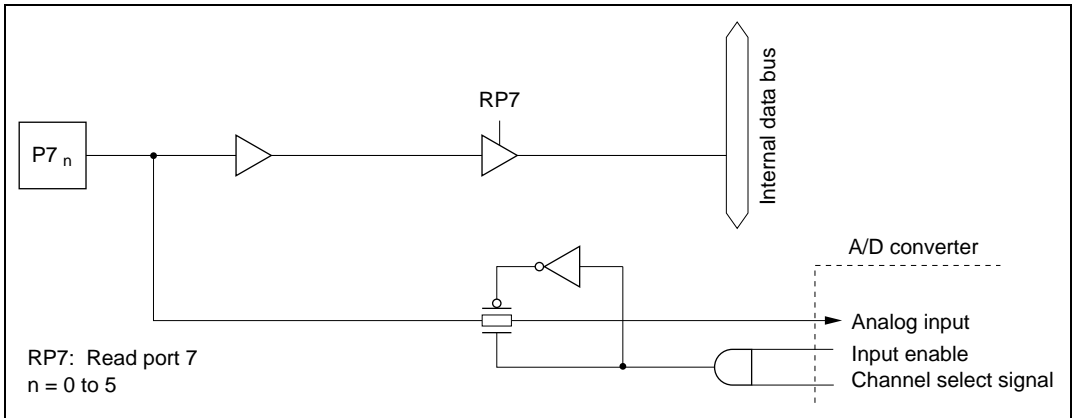

Figure C.7 (a) Port 7 Block Diagram (Pins P7₀ to P7₅)

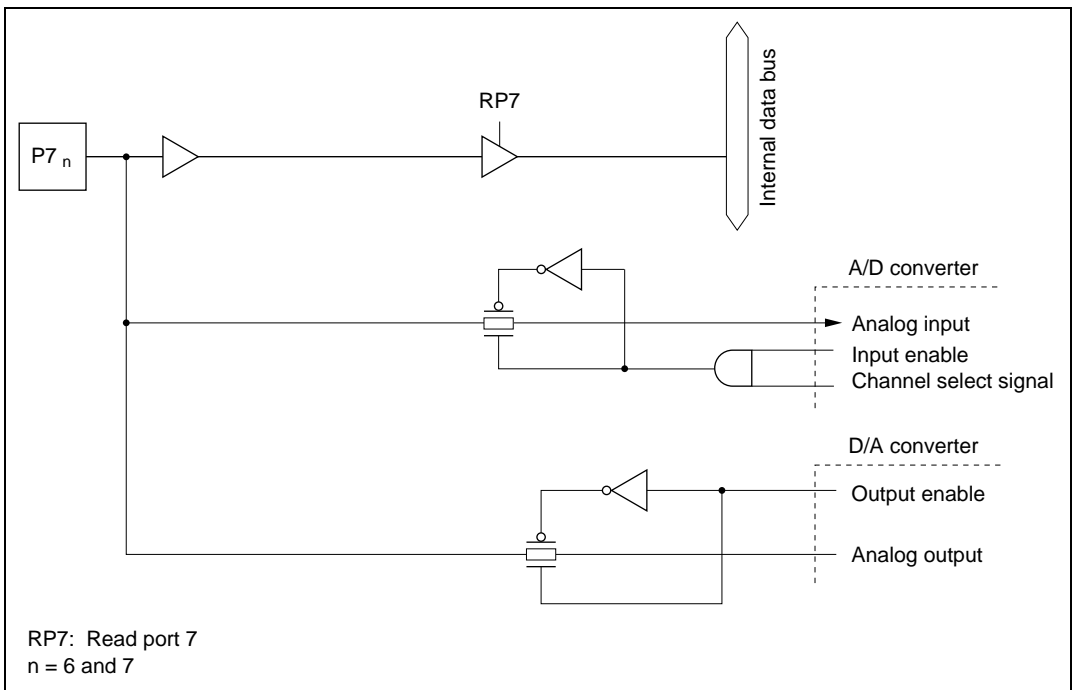

Figure C.7 (b) Port 7 Block Diagram (Pins P7₆ and P7₇)

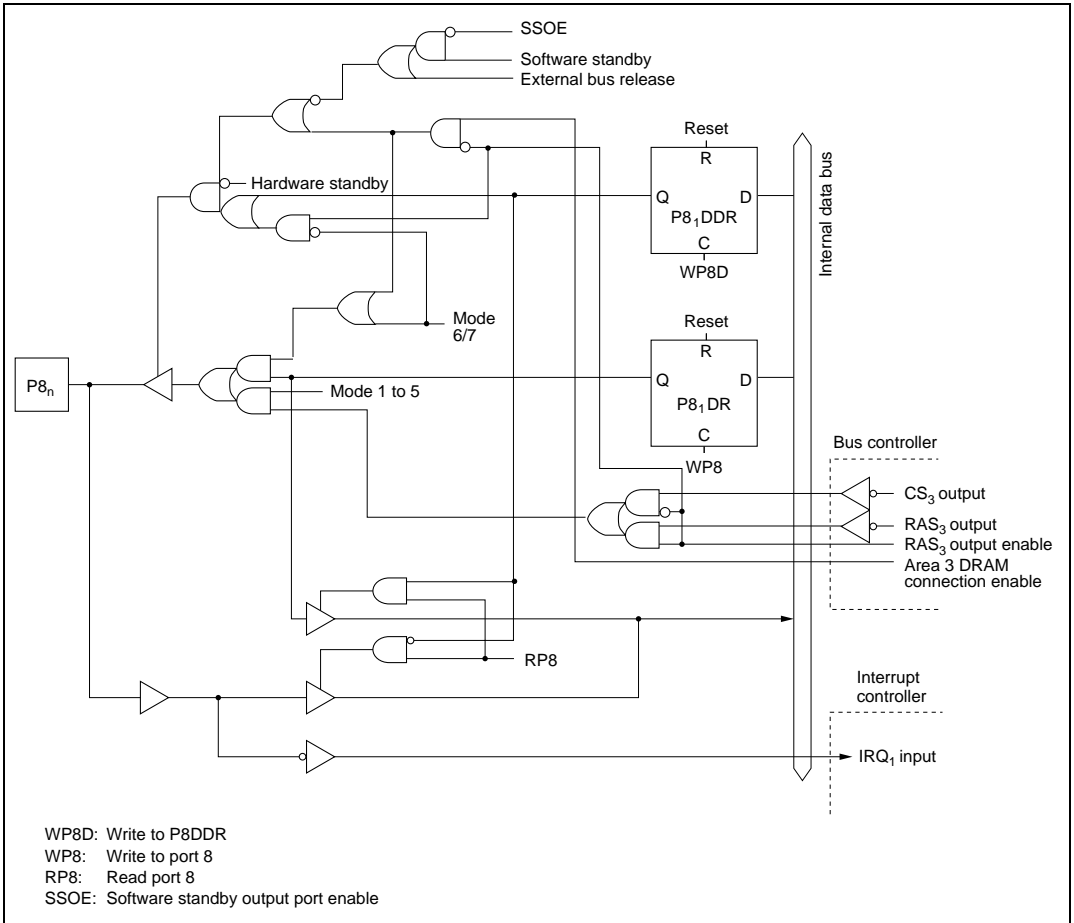
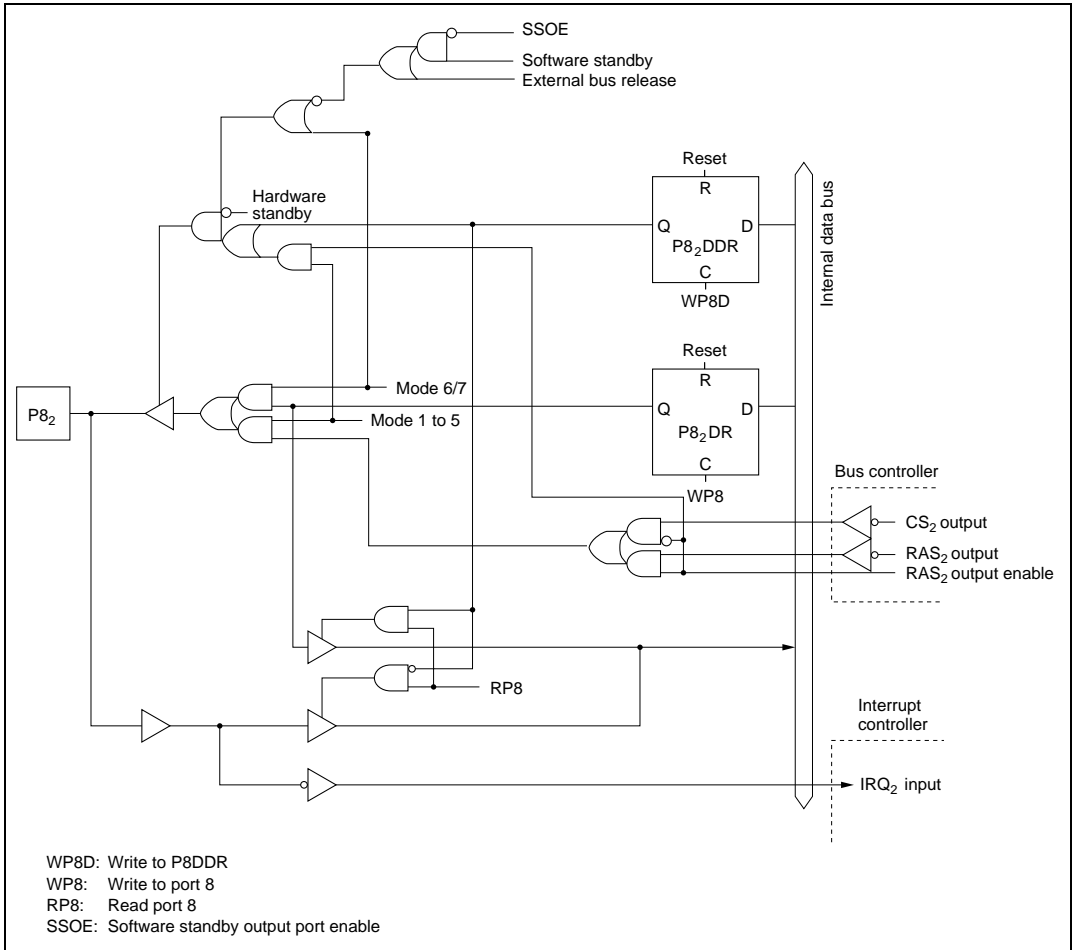

Figure C.8 (b) Port 8 Block Diagram (Pin P8₁)

Figure C.8 (c) Port 8 Block Diagram (Pin P8₂)

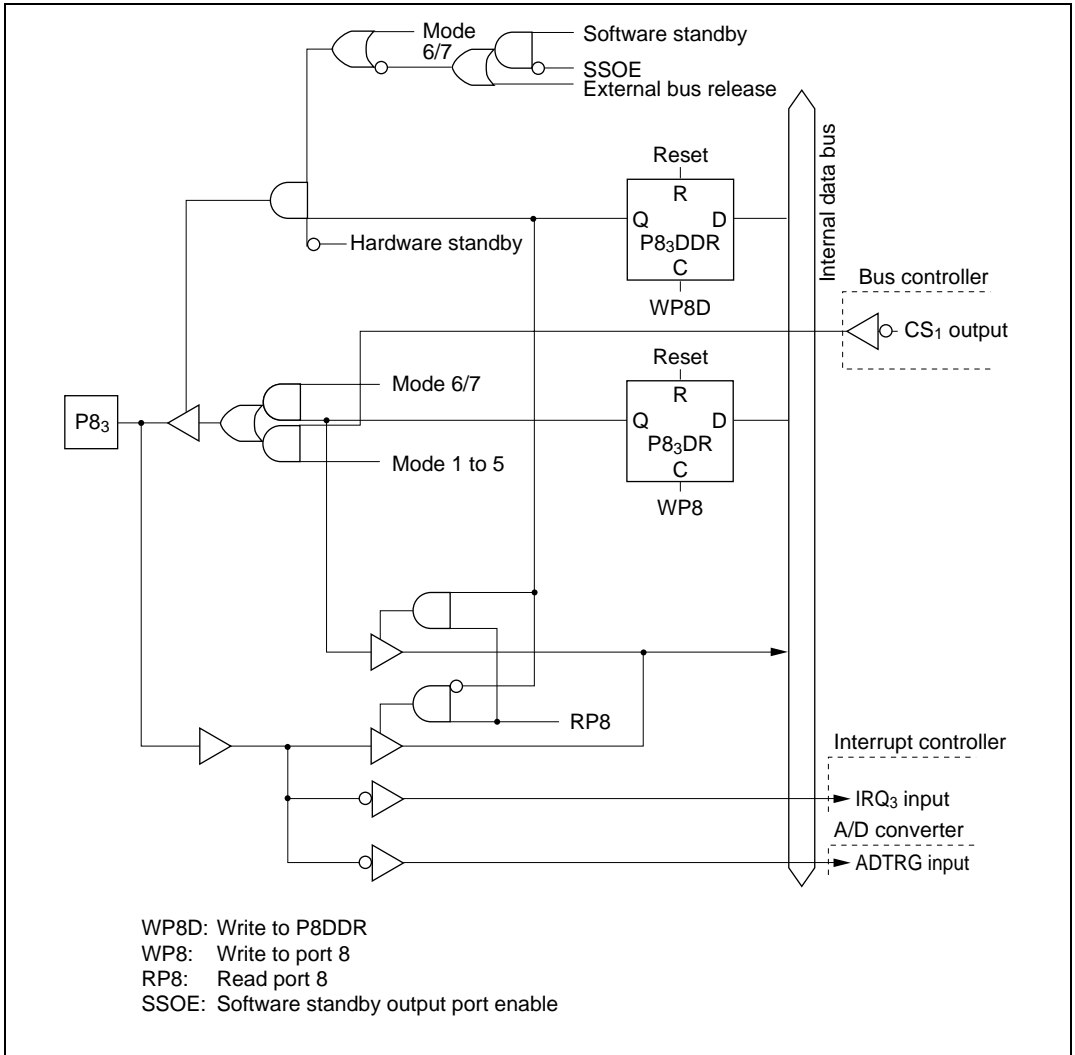

Figure C.8 (d) Port 8 Block Diagram (Pin P83)

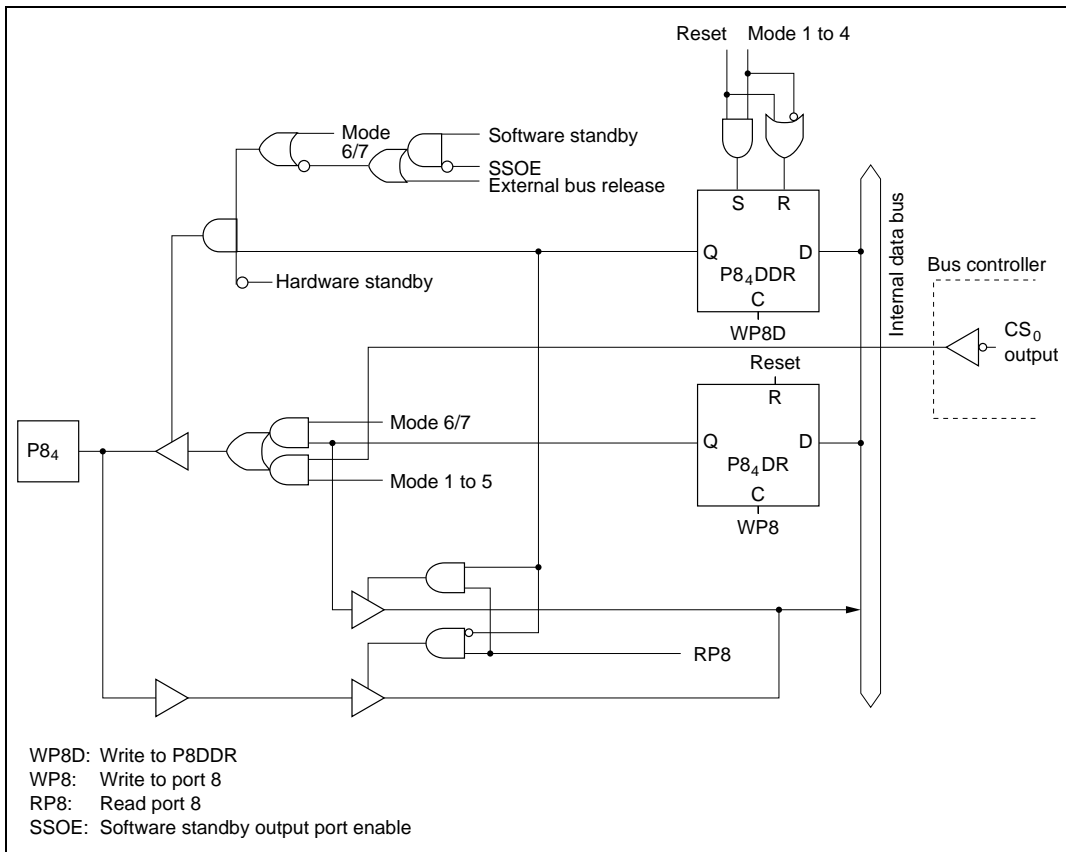

Figure C.8 (e) Port 8 Block Diagram (Pin P84)

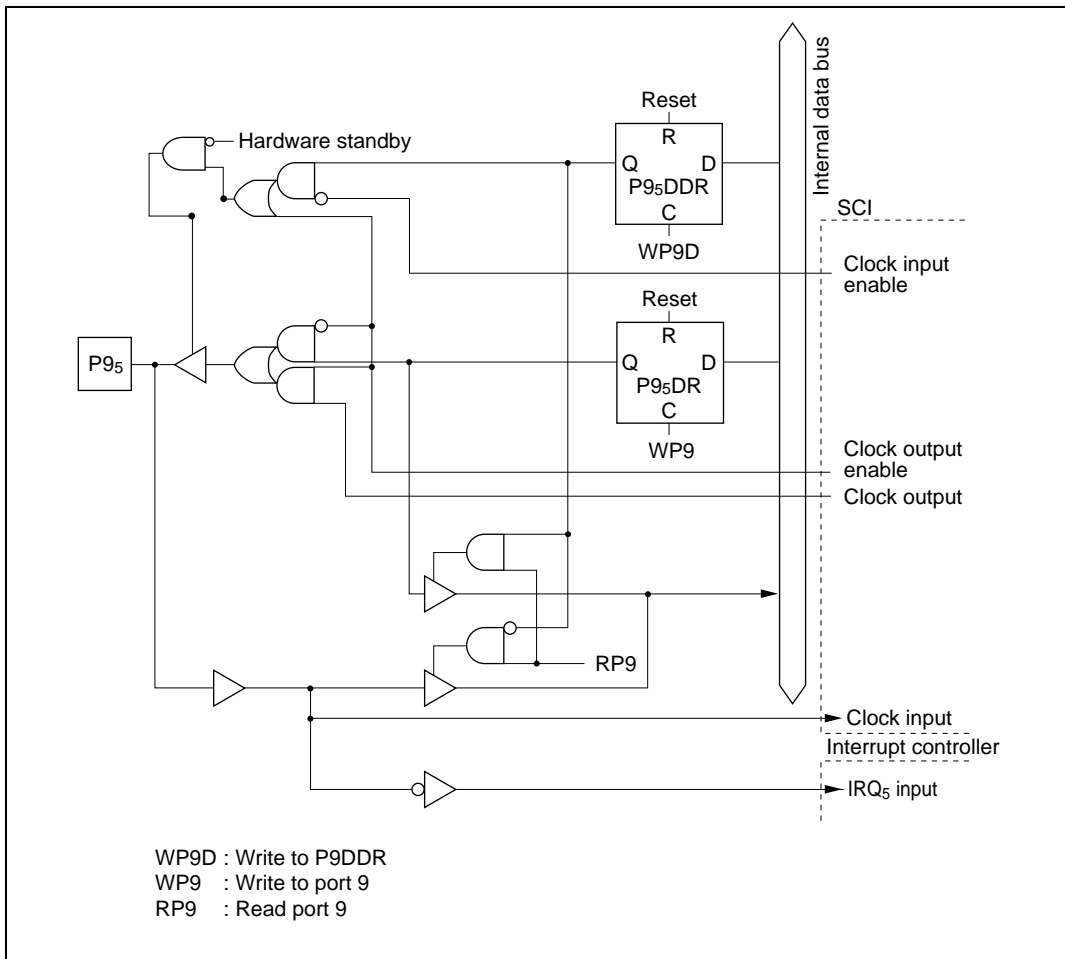

Figure C.9 (f) Port 9 Block Diagram (Pin P95)

C.10 Port A Block Diagrams

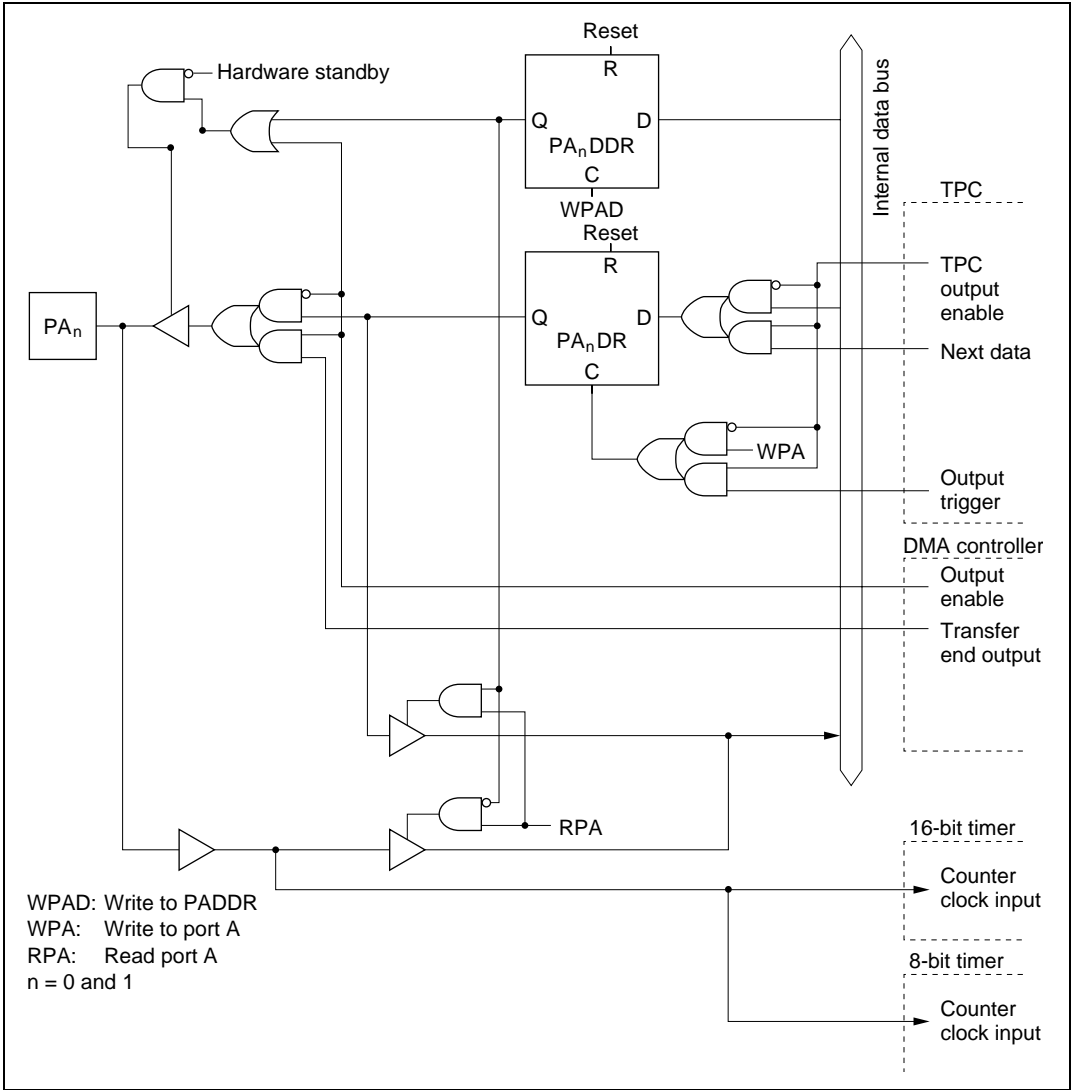

Figure C.10 (a) Port A Block Diagram (Pins PA_0 , PA_1)

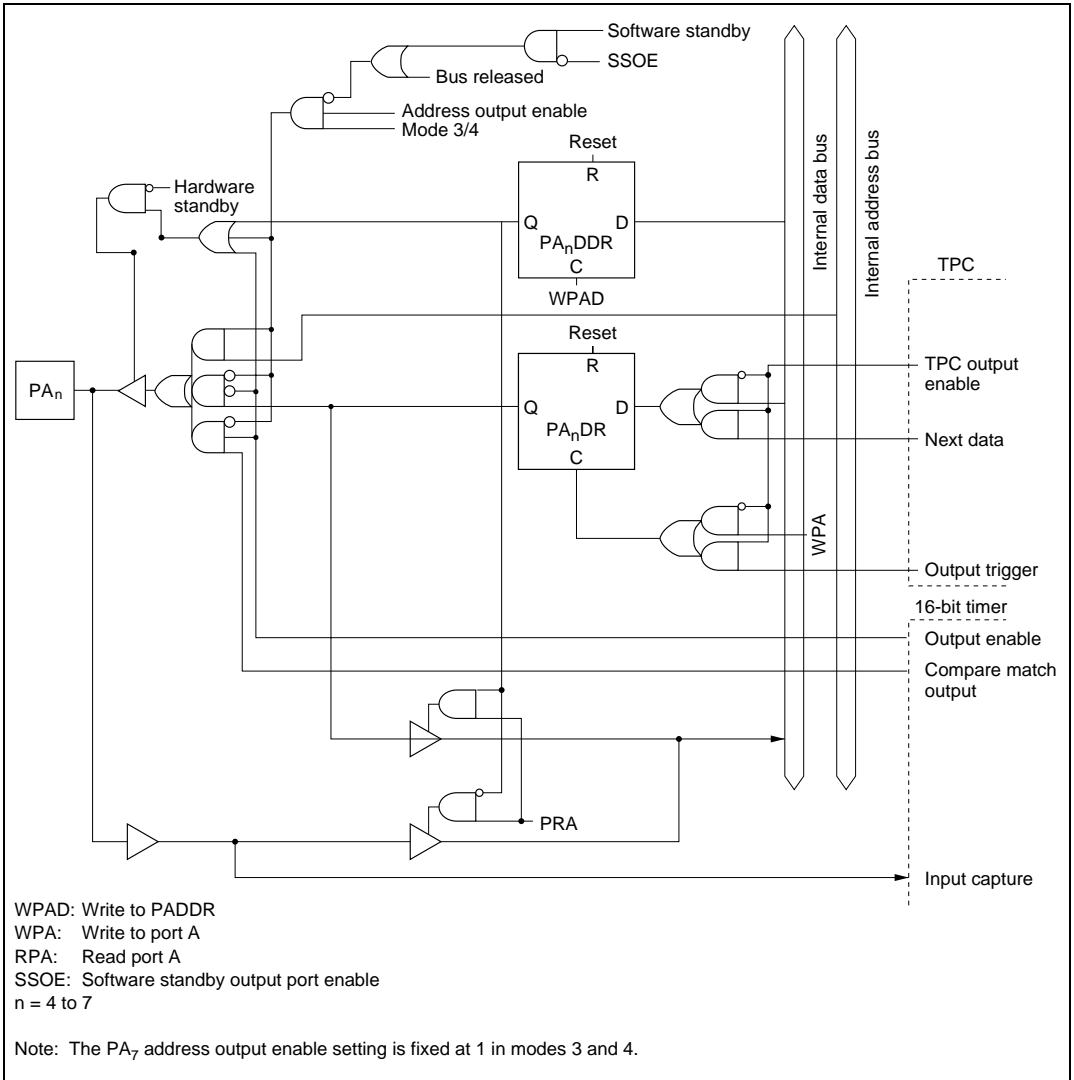
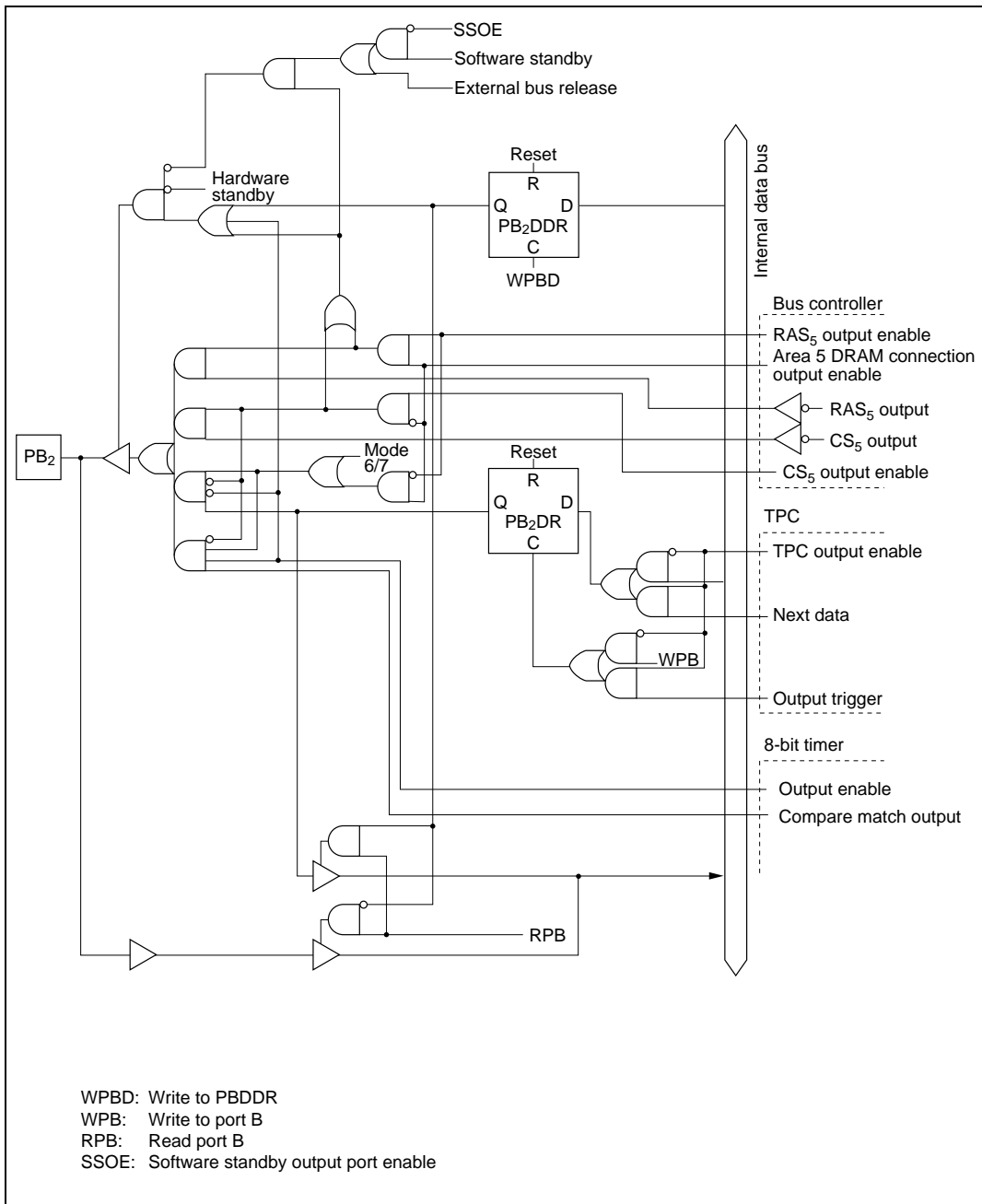

Figure C.10 (c) Port A Block Diagram (Pins PA₄ to PA₇)

Figure C.11 (c) Port B Block Diagram (Pin PB₂)

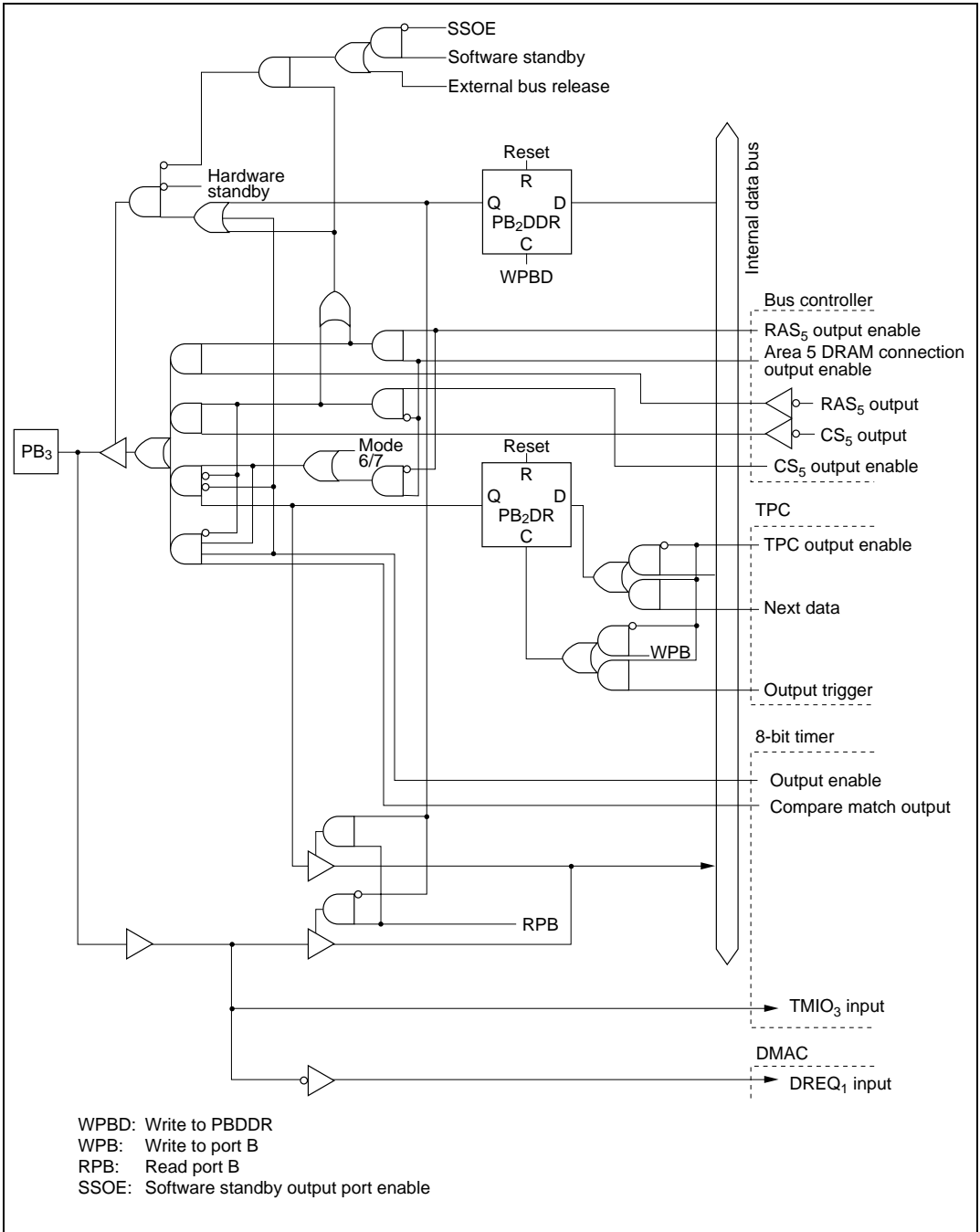

Figure C.11 (d) Port B Block Diagram (Pin PB3)

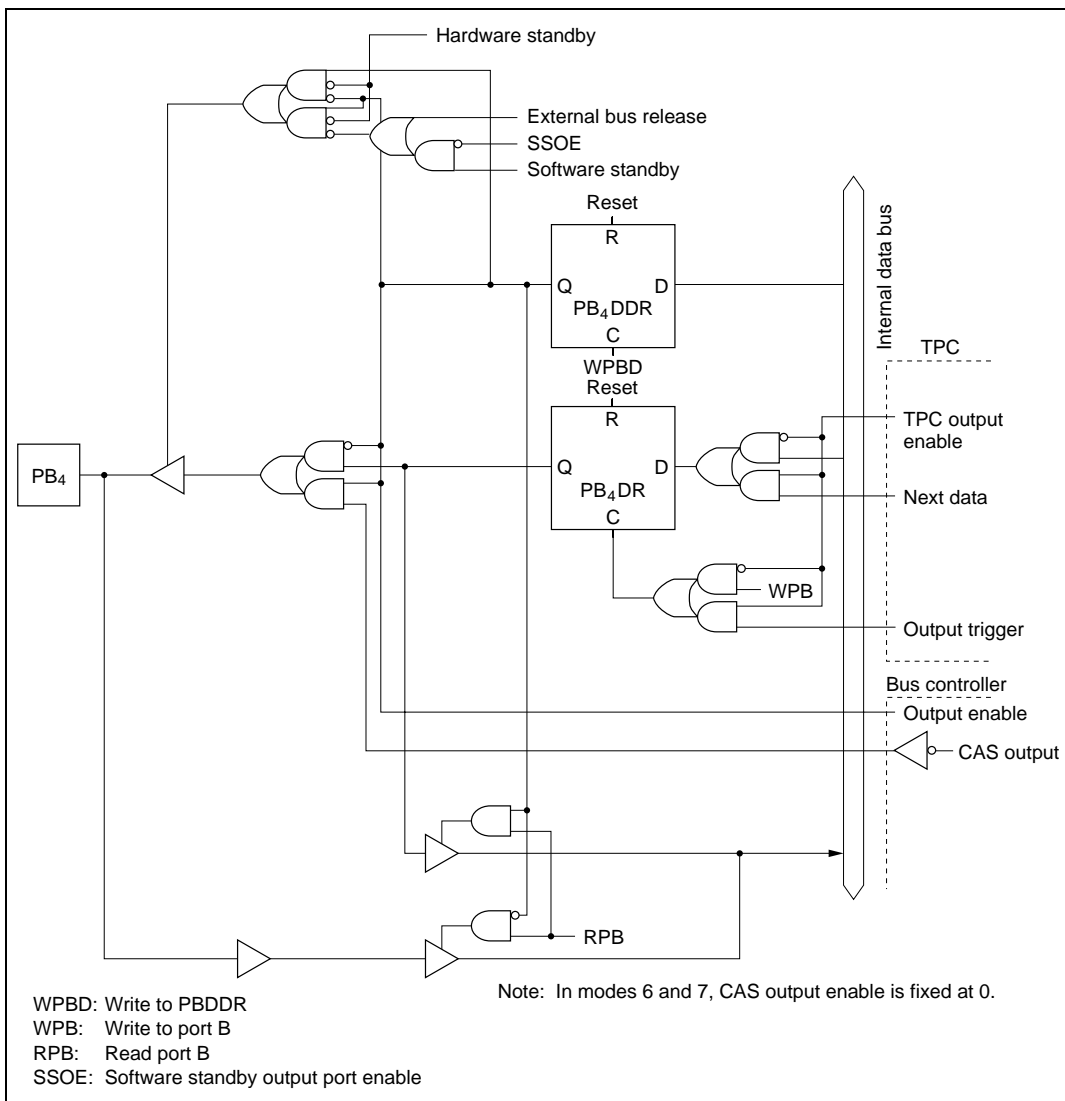

Figure C.11 (e) Port B Block Diagram (Pin PB₄)

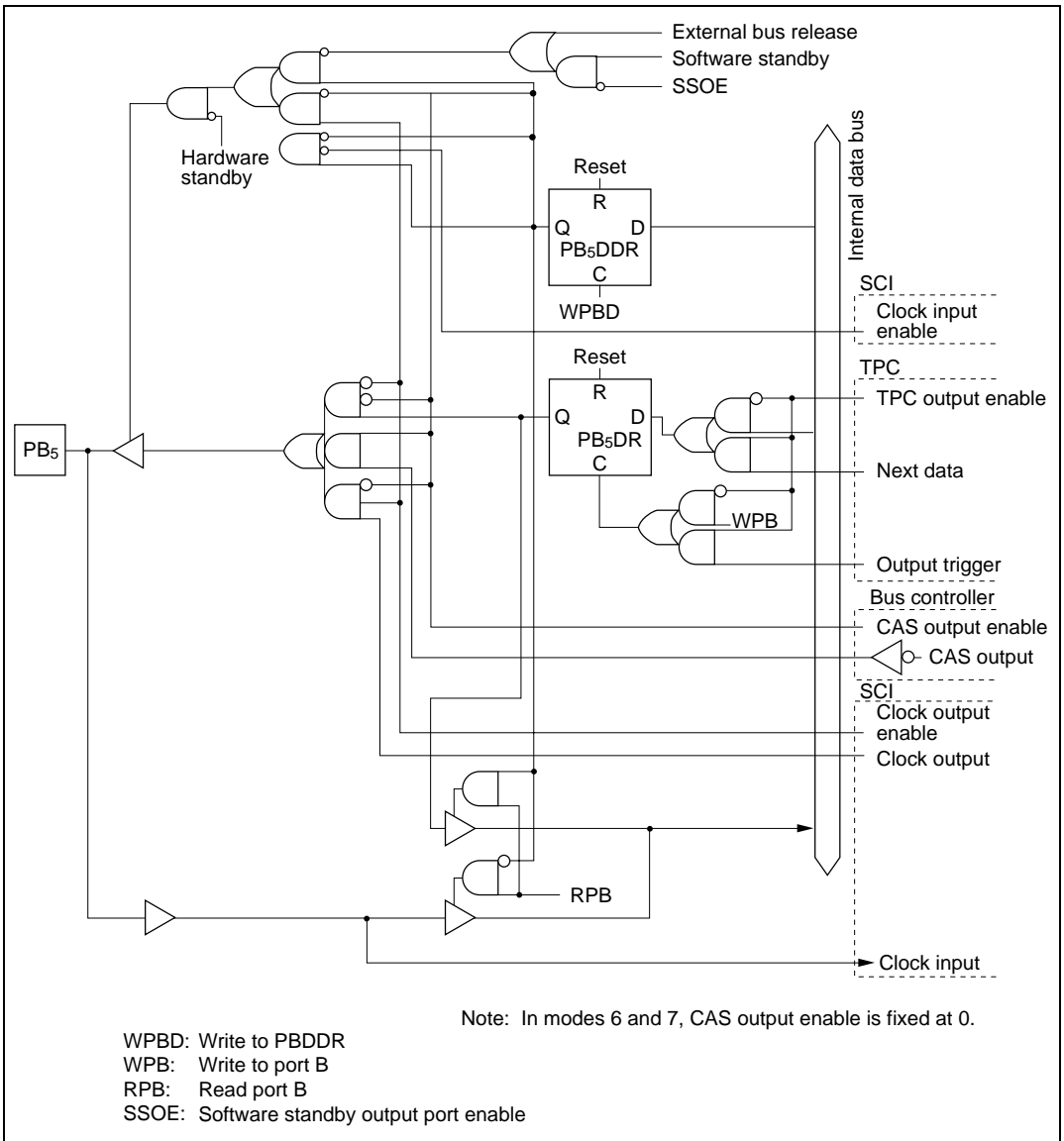
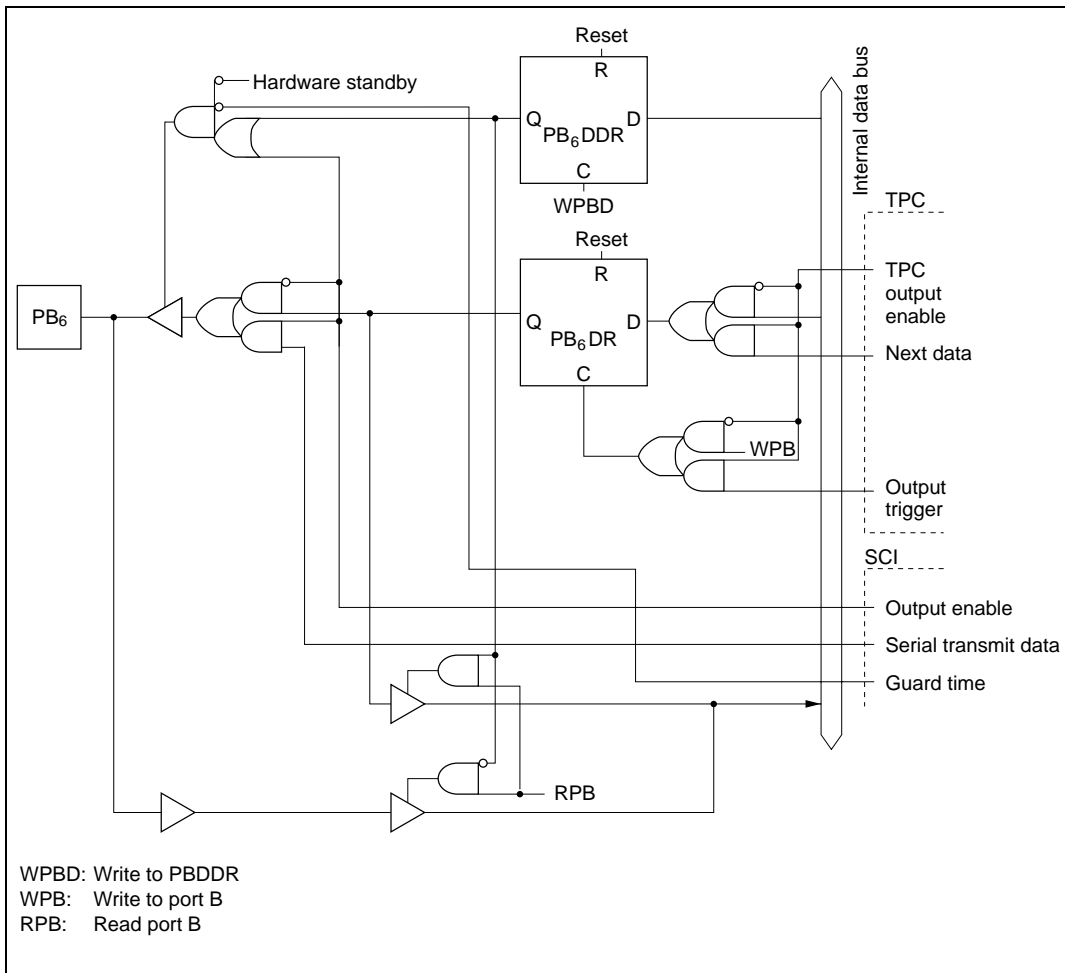

Figure C.11 (f) Port B Block Diagram (Pin PB5)

Figure C.11 (g) Port B Block Diagram (Pin PB₆)

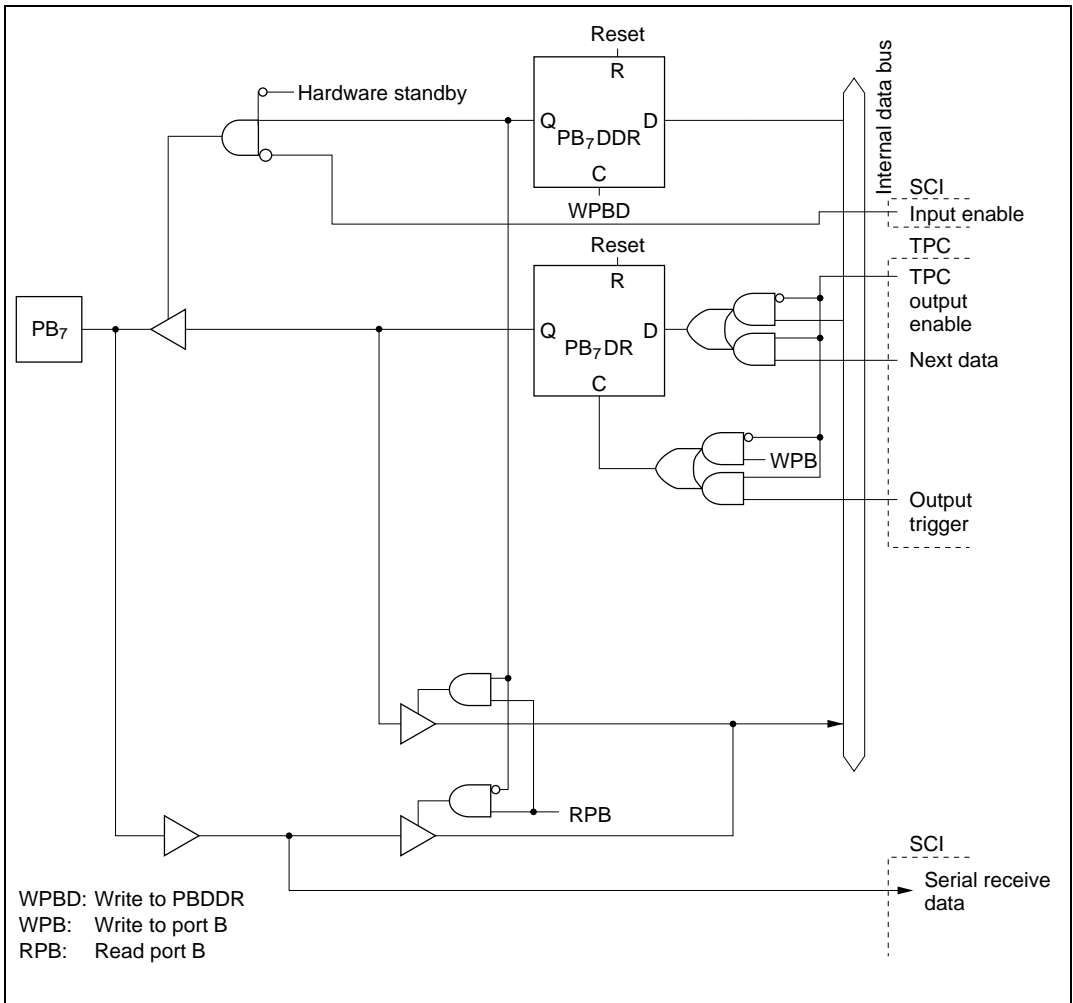

Figure C.11 (h) Port B Block Diagram (Pin PB₇)

Appendix D Pin States

D.1 Port States in Each Mode

Table D.1 Port States

Pin Name	Mode	Reset	Hardware Standby Mode	Software Standby Mode	Bus-Released Mode	Program Execution Mode
P1 ₇ to P1 ₀	1 to 4	L	T	(SSOE=0) T (SSOE=1) Keep	T	A ₇ to A ₀
	5	T	T	(DDR = 0) Keep (DDR=1, SSOE=0) T (DDR=1, SSOE=1) Keep	T	(DDR=0) Input port (DDR=1) A ₇ to A ₀
	6, 7	T	T	Keep	—	I/O port
P2 ₇ to P2 ₀	1 to 4	L	T	(SSOE = 0) T (SSOE = 1) Keep	T	A ₁₅ to A ₈
	5	T	T	(DDR = 0) Keep (DDR=1,SSOE=0) T (DDR=1,SSOE=1) Keep	T	(DDR=0) Input port (DDR=1) A ₁₅ to A ₈
	6, 7	T	T	Keep	—	I/O port
P3 ₇ to P3 ₀	1 to 5	T	T	T	T	D ₁₅ to D ₈
	6, 7	T	T	Keep	—	I/O port
P4 ₇ to P4 ₀	1, 3, 5	T	T	Keep	Keep	I/O port
	2, 4	T	T	T	T	D ₇ to D ₀
	6, 7	T	T	Keep	—	I/O port

Pin Name	Mode	Reset	Hardware Standby Mode	Software Standby Mode	Bus-Released Mode	Program Execution Mode
P5 ₃ to P5 ₀	1 to 4	L	T	(SSOE=0) T (SSOE=1) Keep	T	A ₁₉ to A ₁₆
	5	T	T	(DDR=0) Keep (DDR=1, SSOE=0) T (DDR=1, SSOE=1) Keep	T	(DDR=0) Input port (DDR=1) A ₁₉ to A ₁₆
	6, 7	T	T	Keep	—	I/O port
P6 ₀	1 to 5	T	T	Keep	Keep	I/O port WAIT
	6, 7	T	T	Keep	—	I/O port
P6 ₁	1 to 5	T	T	(BRLE=0) Keep (BRLE=1) T	T	I/O port BREQ
	6, 7	T	T	Keep	—	I/O port
P6 ₂	1 to 5	T	T	(BRLE=0) Keep (BRLE=1) H	L	(BRLE=0) I/O port (BRLE=1) BACK
	6, 7	T	T	Keep	—	I/O port
P6 ₆ to P6 ₃	1 to 5	H	T	(SSOE=0) T (SSOE=1) H	T	AS, RD, HWR, LWR
	6, 7	T	T	Keep	—	I/O port
P6 ₇	1 to 7	Clock output	T	(PSTOP=0) H (PSTOP=1) Keep	(PSTOP=0) ϕ (PSTOP=1) Keep	(PSTOP=0) ϕ (PSTOP=1) Input port
P7 ₇ to P7 ₀	1 to 7	T	T	T	T	Input port

Pin Name	Mode	Reset	Hardware Standby Mode	Software Standby Mode	Bus-Released Mode	Program Execution Mode
P8 ₀	1 to 5	T	T	When DRAM space is not selected*1 (RFSHE=0) Keep (RFSHE=1) Illegal setting	When DRAM space is selected*1 (RFSHE=0) Keep (RFSHE=1) Illegal setting	(RFSHE=0) I/O port (RFSHE=1) RFSH
				When DRAM space is selected*2 (RFSHE=0) Keep (RFSHE=1, SRFMD=0, SSOE=0) T (RFSHE=1, SRFMD=0, SSOE=1) H (RFSHE=1, SRFMD=1) RFSH	When DRAM space is selected*2 (RFSHE=0) Keep (RFSHE=1) T	
	6, 7	T	T	Keep	—	I/O port
P8 ₁	1 to 5	T	T	When DRAM space is selected*3 (SSOE=0) T (SSOE=1) H	When DRAM space is selected*3 T When DRAM space is selected*4 Keep Otherwise*1 (DDR=0)	When DRAM space is selected and RAS3 is output RAS ₃ When DRAM space is selected and RAS3 is not output I/O port Otherwise (DDR=0) Input port (DDR=1) CS ₃
				When DRAM space is selected*4 Keep Otherwise*5 *1 (DDR=0) T (DDR=1, SSOE=0) T (DDR=1, SSOE=1) H	Keep (DDR=1) T	
	6, 7	T	T	Keep	—	I/O port

Pin Name	Mode	Reset	Hardware Standby Mode	Software Standby Mode	Bus-Released Mode	Program Execution Mode
P8 ₂	1 to 5	T	T	RAS ₂ output* ² (SSOE=0) T (SSOE=1) H Otherwise* ¹ (DDR=0) T (DDR=1, SSOE=0) T (DDR=1, SSOE=1) H	RAS ₂ output* ² T Otherwise* ¹ (DDR=0) Keep (DDR=1) T	RAS ₂ output RAS ₂ Otherwise (DDR=0) I/O port (DDR=1) CS ₂
	6, 7	T	T	Keep	—	I/O port
P8 ₃	1 to 5	T	T	(DDR=0) T (DDR=1, SSOE=0) T (DDR=1, SSOE=1) H	(DDR=0) Keep (DDR=1) T	(DDR=0) Input port (DDR=1) CS ₁
	6, 7	T	T	Keep	—	I/O port
P8 ₄	1 to 4	H	T	(DDR=0) T (DDR=1, SSOE=0) T (DDR=1, SSOE=1) H	(DDR = 0) Keep (DDR = 1) T	(DDR = 0) Input port (DDR = 1) CS ₀
	5	T	T	(DDR=0) T (DDR=1, SSOE=0) T (DDR=1, SSOE=1) H	(DDR=0) Keep (DDR=1) T	(DDR=0) Input port (DDR=1) CS ₀
	6, 7	T	T	Keep	—	I/O port
P9 ₅ to P9 ₀	1 to 7	T	T	Keep	Keep	I/O port
PA ₃ to PA ₀	1 to 7	T	T	Keep	Keep	I/O port
PA ₆ to PA ₄	1, 2, 6, 7	T	T	Keep	Keep	I/O port

Pin Name	Mode	Reset	Hardware Standby Mode	Software Standby Mode	Bus-Released Mode	Program Execution Mode
PA ₆ to PA ₄	3 to 5	T	T	Address output* ⁵ (SSOE=0) T (SSOE=1) Keep Otherwise* ⁶ Keep	Address output* ⁵ T Otherwise* ⁶ Keep	Address output A ₂₃ to A ₂₁ Otherwise I/O port
PA ₇	1, 2	T	T	Keep	Keep	I/O port
	3, 4	L	T	(SSOE=0) T (SSOE=1) Keep	T	A ₂₀
	5	L	T	When A20E = 0 SSOE = 0 T SSOE = 1 Keep When A20E = 1 Keep	When A20E = 0 T When A20E = 1 Keep	When A20E = 0 A ₂₀ When A20E = 1 I/O port
	6, 7	T	T	Keep	—	I/O port
PB ₁ to PB ₀	1 to 5	T	T	CS output* ⁷ (SSOE=0) T (SSOE=1) H Otherwise* ⁸ Keep	CS output* ⁷ T Otherwise* ⁸ Keep	CS output CS ₇ to CS ₆ Otherwise I/O port
	6, 7	T	T	Keep	—	I/O port
PB ₂	1 to 5	T	T	RAS5 output* ⁹ (SSOE=0) T (SSOE=1) H CS output* ¹⁰ (SSOE=0) T (SSOE=1) H Otherwise* ¹¹ Keep	RAS5 output* ⁹ T CS output* ¹⁰ T Otherwise* ¹¹ Keep	RAS5 output RAS ₅ CS output CS ₅ Otherwise I/O port
	6, 7	T	T	Keep	—	I/O port

Pin Name	Mode	Reset	Hardware Standby Mode	Software Standby Mode	Bus-Released Mode	Program Execution Mode
PB ₃	1 to 5	T	T	RAS4 output*12 (SSOE=0)	RAS4 output*12 T	RAS4 output <u>RAS4</u>
				T (SSOE=1)	CS output*13 T	CS output <u>CS4</u>
				H CS output*13 (SSOE=0)	Otherwise*14 Keep	Otherwise I/O port
				T (SSOE=1)		
				H Otherwise*14		
				Keep		
	6, 7	T	T	Keep	—	I/O port
PB ₅ to PB ₄	1 to 5	T	T	CAS output*15 (SSOE=0)	CAS output*15 T	CAS output <u>UCAS</u> , <u>LCAS</u>
				T (SSOE=1)	Otherwise*16 Keep	Otherwise I/O port
				H Otherwise*16		
				Keep		
	6, 7	T	T	Keep	—	I/O port
PB ₇ to PB ₆	1 to 7	T	T	Keep	Keep	I/O port

Legend

H: High

L: Low

T: High-impedance state

Keep: Input pins are in the high-impedance state; output pins maintain their previous state.

DDR: Data direction register

- Notes:
1. When bits DRAS2, DRAS1, and DRAS0 in DRCRA (DRAM control register A) are all cleared to 0.
 2. When any of bits DRAS2, DRAS1, or DRAS0 in DRCRA (DRAM control register A) is set to 1.
 3. When the setting of bits DRAS2, DRAS1, and DRAS0 in DRCRA (DRAM control register A) is 010, 100, or 101.
 4. When the setting of bits DRAS2, DRAS1, and DRAS0 in DRCRA (DRAM control register A) is other than 010, 100, 101, or 000.
 5. When bit A23E, A22E, or A21E, respectively, in BRCCR (bus release control register) is cleared to 0.
 6. When bit A23E, A22E, or A21E, respectively, in BRCCR (bus release control register) is set to 1.
 7. When bit CS7E or CS6E, respectively, in CSCR (chip select control register) is set to 1.

8. When bit CS7E or CS6E, respectively, in CSCR (chip select control register) is cleared to 0.
9. When the setting of bits DRAS2, DRAS1, and DRAS0 in DRCRA (DRAM control register A) is 101.
10. When the setting of bits DRAS2, DRAS1, and DRAS0 in DRCRA (DRAM control register A) is other than 101, and bit CS5E in CSCR (chip select control register) is set to 1.
11. When the setting of bits DRAS2, DRAS1, and DRAS0 in DRCRA (DRAM control register A) is other than 101, and bit CS5E in CSCR (chip select control register) is cleared to 0.
12. When the setting of bits DRAS2, DRAS1, and DRAS0 in DRCRA (DRAM control register A) is 100, 101, or 110.
13. When the setting of bits DRAS2, DRAS1, and DRAS0 in DRCRA (DRAM control register A) is other than 100, 101, or 110, and bit CS4E in CSCR (chip select control register) is set to 1.
14. When the setting of bits DRAS2, DRAS1, and DRAS0 in DRCRA (DRAM control register A) is other than 100, 101, or 110, and bit CS4E in CSCR (chip select control register) is cleared to 0.
15. When any of bits DRAS2, DRAS1, or DRAS0 in DRCRA (DRAM control register A) is set to 1, and bit CSEL in DRCRB (DRAM control register B) is cleared to 0.
16. When any of bits DRAS2, DRAS1, or DRAS0 in DRCRA (DRAM control register A) is set to 1, and bit CSEL in DRCRB (DRAM control register B) is set to 1; or, when bits DRAS2, DRAS1, and DRAS0 are all cleared to 0.

D.2 Pin States at Reset

Modes 1 and 2: Figure D.1 is a timing diagram for the case in which $\overline{\text{RES}}$ goes low during an external memory access in mode 1 or 2. As soon as $\overline{\text{RES}}$ goes low, all ports are initialized to the input state. $\overline{\text{AS}}$, $\overline{\text{RD}}$, $\overline{\text{HWR}}$, $\overline{\text{LWR}}$, and $\overline{\text{CS}}_0$ go high, and D_{15} to D_0 go to the high-impedance state. The address bus is initialized to the low output level 2.5 ϕ clock cycles after the low level of $\overline{\text{RES}}$ is sampled. Clock pin P_{67}/ϕ goes to the output state at the next rise of ϕ after $\overline{\text{RES}}$ goes low.

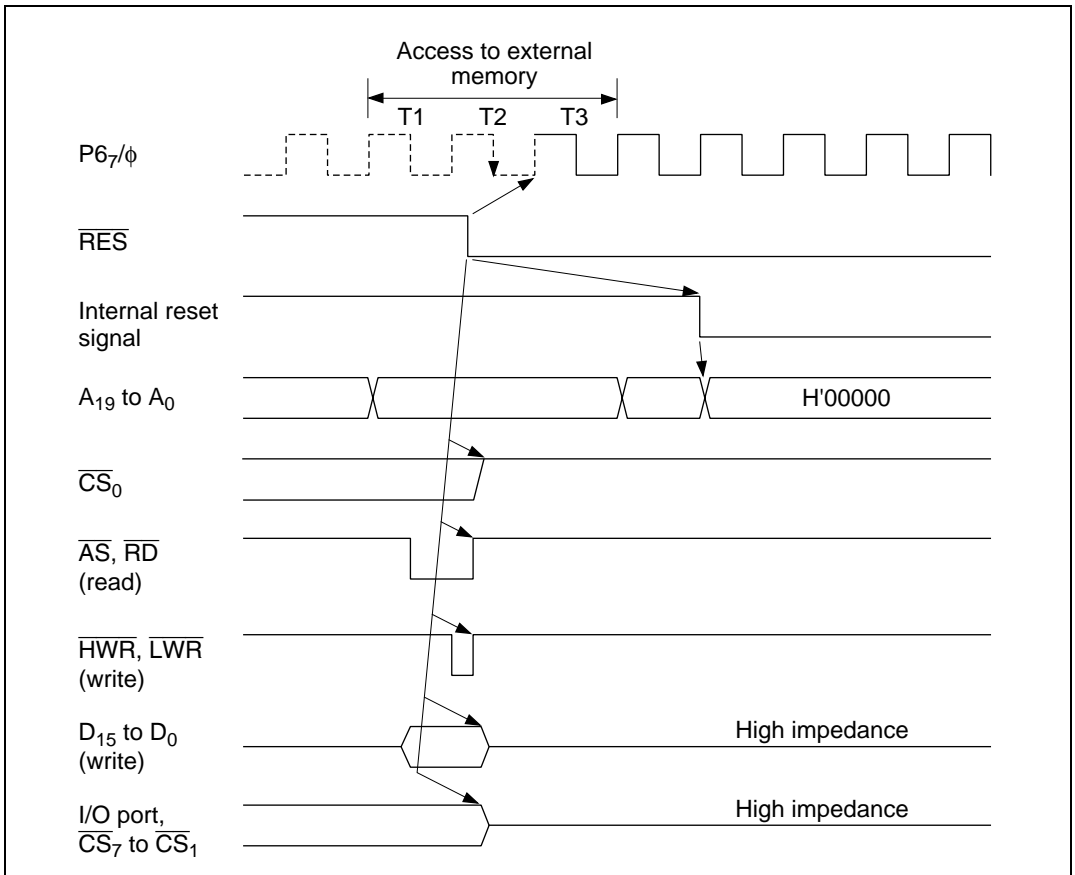

Figure D.1 Reset during Memory Access (Modes 1 and 2)

Modes 3 and 4: Figure D.2 is a timing diagram for the case in which $\overline{\text{RES}}$ goes low during an external memory access in mode 3 or 4. As soon as $\overline{\text{RES}}$ goes low, all ports are initialized to the input state. $\overline{\text{AS}}$, $\overline{\text{RD}}$, $\overline{\text{HWR}}$, $\overline{\text{LWR}}$, and $\overline{\text{CS}}_0$ go high, and D_{15} to D_0 go to the high-impedance state. The address bus is initialized to the low output level 2.5 ϕ clock cycles after the low level of $\overline{\text{RES}}$ is sampled. However, when PA_4 to PA_6 are used as address bus pins, or when P_{83} to P_{81} and PB_0

to PB₃ are used as CS output pins, they go to the high-impedance state at the same time as $\overline{\text{RES}}$ goes low. Clock pin P6₇/φ goes to the output state at the next rise of φ after $\overline{\text{RES}}$ goes low.

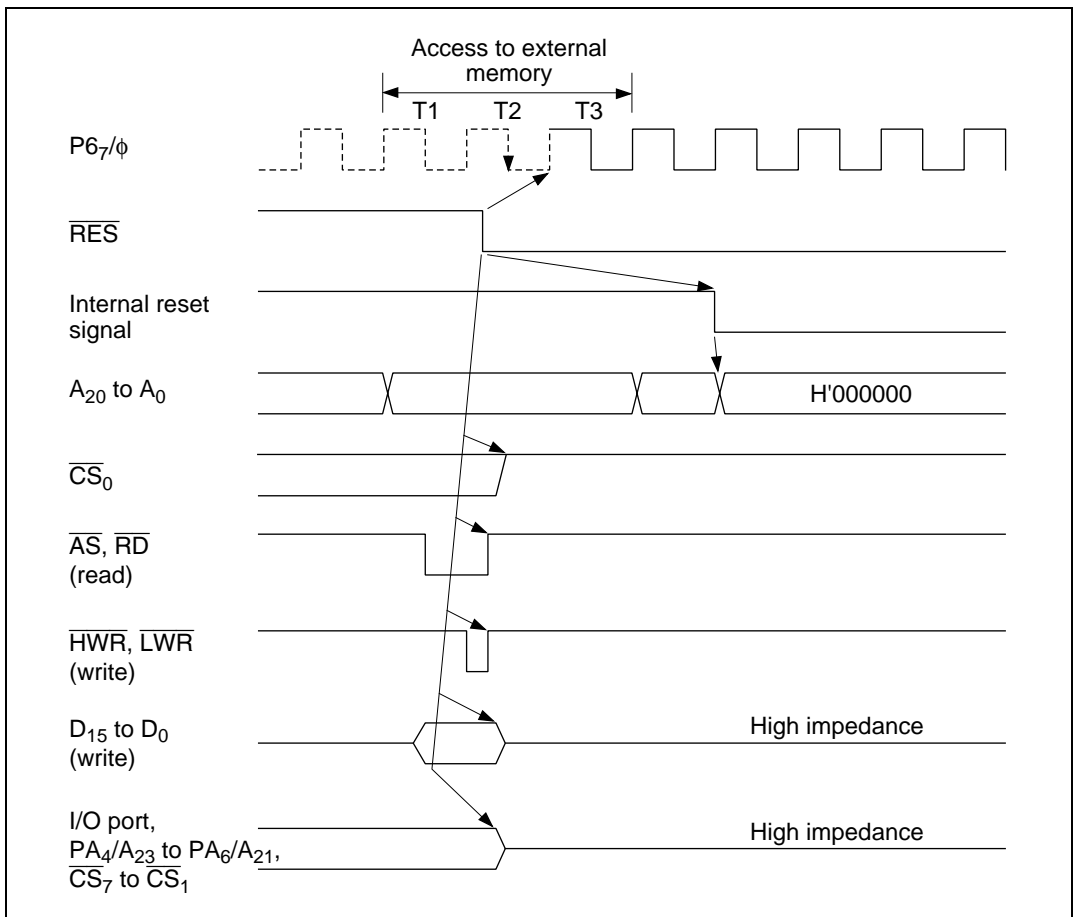

Figure D.2 Reset during Memory Access (Modes 3 and 4)

Mode 5: Figure D.3 is a timing diagram for the case in which $\overline{\text{RES}}$ goes low during an external memory access in mode 5. As soon as $\overline{\text{RES}}$ goes low, all ports are initialized to the input state. $\overline{\text{AS}}$, $\overline{\text{RD}}$, $\overline{\text{HWR}}$, and $\overline{\text{LWR}}$ go high, and the address bus and D₁₅ to D₀ go to the high-impedance state. Clock pin P6₇/φ goes to the output state at the next rise of φ after $\overline{\text{RES}}$ goes low.

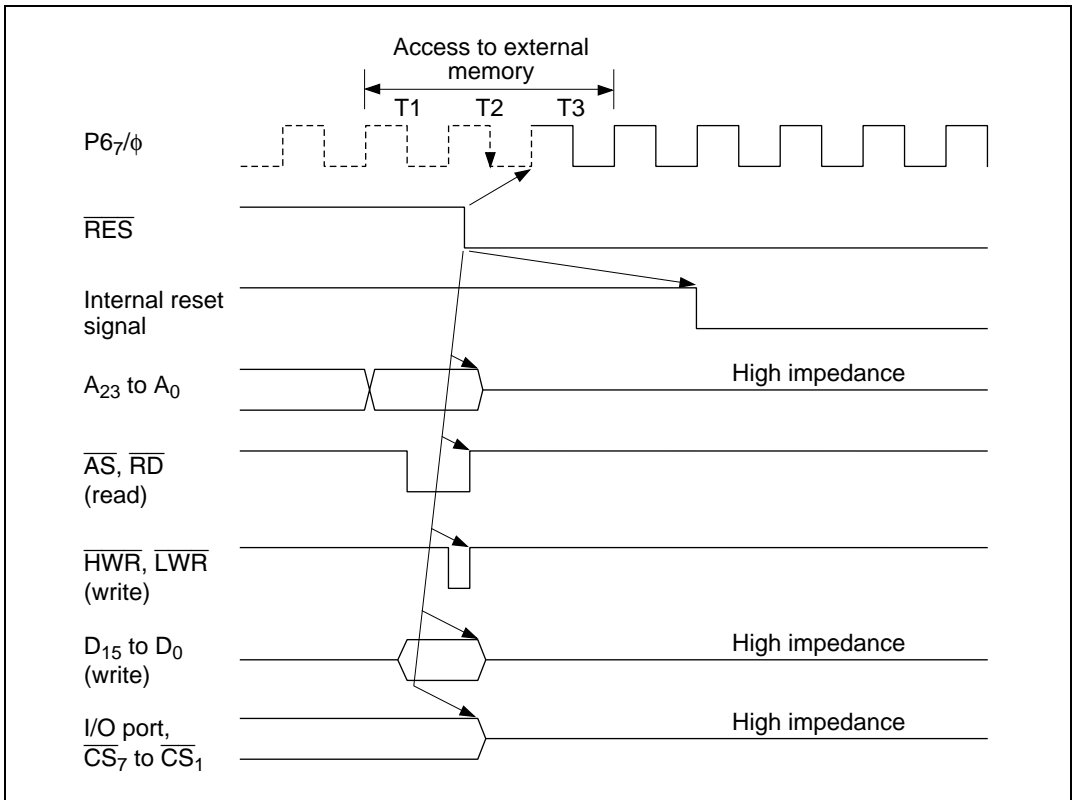

Figure D.3 Reset during Memory Access (Mode 5)

Modes 6 and 7: Figure D.4 is a timing diagram for the case in which $\overline{\text{RES}}$ goes low during an operation in mode 6 or 7. As soon as $\overline{\text{RES}}$ goes low, all ports are initialized to the input state. Clock pin P6₇/φ goes to the output state at the next rise of φ after $\overline{\text{RES}}$ goes low.

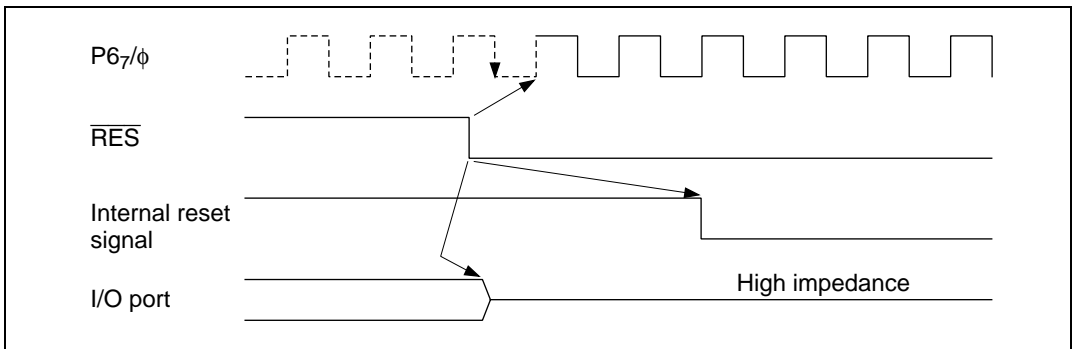
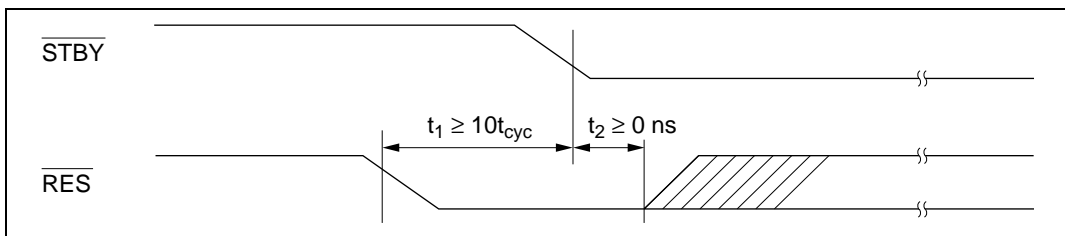

Figure D.4 Reset during Operation (Modes 6 and 7)

Appendix E Timing of Transition to and Recovery from Hardware Standby Mode

Timing of Transition to Hardware Standby Mode

1. To retain RAM contents with the RAME bit set to 1 in SYSCR, drive the $\overline{\text{RES}}$ signal low 10 system clock cycles before the $\overline{\text{STBY}}$ signal goes low, as shown below. $\overline{\text{RES}}$ must remain low until $\overline{\text{STBY}}$ goes low (minimum delay from $\overline{\text{STBY}}$ low to $\overline{\text{RES}}$ high: 0 ns).



2. To retain RAM contents with the RAME bit cleared to 0 in SYSCR, $\overline{\text{RES}}$ does not have to be driven low as in (1).

Timing of Recovery from Hardware Standby Mode: Drive the $\overline{\text{RES}}$ signal low approximately 100 ns before $\overline{\text{STBY}}$ goes high.

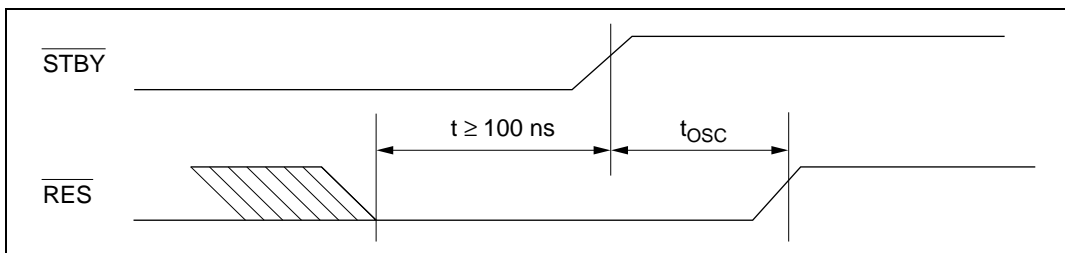

Appendix F Product Code Lineup

Product Type	Product Code	Mark Code	Package (Package Code)
H8/3068F On-chip flash 5 V memory	HD64F3068F	HD64F3068F	100-pin QFP (FP-100B)
	HD64F3068TE	HD64F3068TE	100-pin TQFP (TFP-100B)

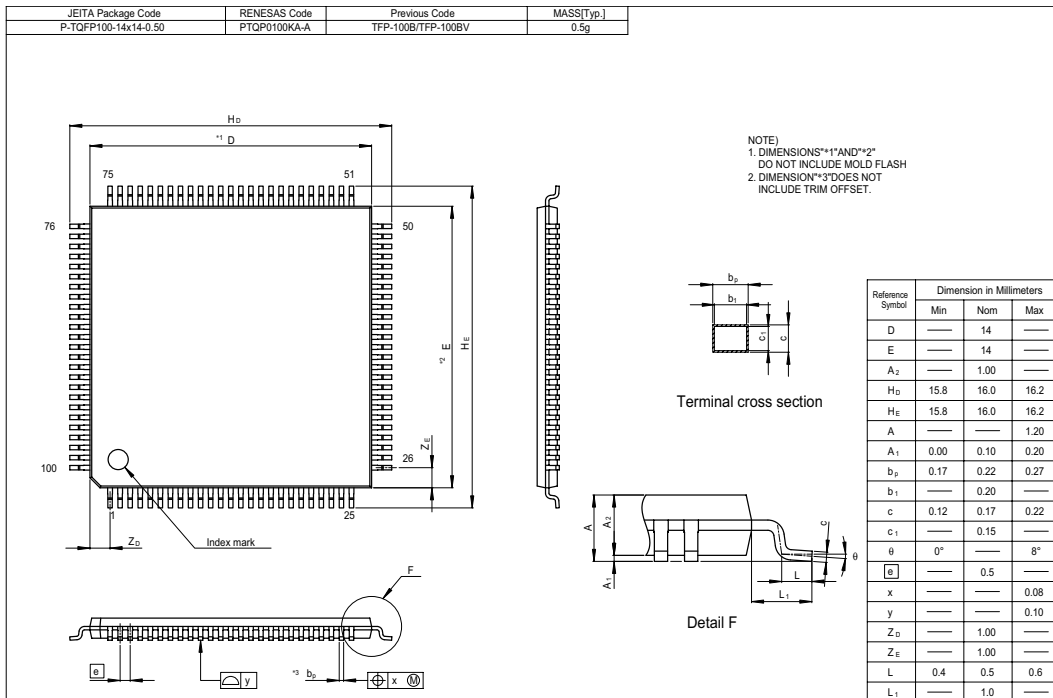

Figure G.2 Package Dimensions (TFP-100B)

Appendix H Comparison of H8/300H Series Product Specifications

H.1 Differences between H8/3068F and H8/3067 Group and H8/3062 Group, H8/3048 Group

Item		H8/3068F	H8/3067 Group, H8/3062 Group	H8/3048 Group
1	Operating mode	Mode 5	16 Mbytes ROM enabled expanded mode	16 Mbytes ROM enabled expanded mode
		Mode 6	64 kbytes single-chip mode	64 kbytes single-chip mode
				1 Mbyte ROM enabled expanded mode
				16 Mbyte ROM enabled expanded mode
2	Interrupt controller	Internal interrupt sources	36	36 (H8/3067) 27 (H8/3062)
3	Bus controller	Burst ROM interface	Yes	Yes (H8/3067) No (H8/3062)
		Idle cycle insertion function	Yes	Yes
	Wait mode	2 modes	2 modes	4 modes
	Wait state number setting	Per area	Per area	Common to all areas
	Address output method	Choice of address update fixed	Choice of address update mode (mask ROM and flash memory R versions only)	Fixed
4	DRAM interface	Connectable areas	Area 2/3/4/5	Area 2/3/4/5 (H8/3067 only)
		Precharge cycle insertion function	Yes	Yes (H8/3067 only)
		Fast page mode	Yes	Yes (H8/3067 only)
		Address shift amount	8 bit/9 bit/10 bit	8 bit/9 bit/10 bit (H8/3067 only)

Item		H8/3067 Group, H8/3062 Group				H8/3048 Group	
		H8/3068F					
5	Timer functions	16-bit timers	8-bit timers	16-bit timers	8-bit timers	ITU	
		Number of channels	16 bits × 3	8 bits × 4 (16 bits × 2)	16 bits × 3	8 bits × 4 (16 bits × 2)	16 bits × 5
		Pulse output	6 pins	4 pins (2 pins)	6 pins	4 pins (2 pins)	12 pins
		Input capture	6	2	6	2	10
		External clock	4 systems (selectable)	4 systems (fixed)	4 systems (selectable)	4 systems (fixed)	4 systems (selectable)
		Internal clock	φ, φ/2, φ/4, φ/8	φ/8, φ/64, φ/8192	φ, φ/2, φ/4, φ/8	φ/8, φ/64, φ/8192	φ, φ/2, φ/4, φ/8
		Complementary PWM function	No	No	No	No	Yes
		Reset-synchronous PWM function	No	No	No	No	Yes
		Buffer operation	No	No	No	No	Yes
		Output initialization function	Yes	No	Yes	No	No
		PWM output	3	4 (2)	3	4 (2)	5
		DMAC activation	3 channels	No	3 channels (H8/3067 only)	No	4 channels
		A/D conversion activation	No	Yes	No	Yes	No
Interrupt sources	3 sources × 3	8 sources	3 sources × 3	8 sources	3 sources × 5		
6	TPC	Time base	3 kinds, 16-bit timer base	3 kinds, 16-bit timer base	4 kinds, ITU base		
7	WDT	Reset signal external output function	No	Yes (except products with on-chip flash memory)	Yes		
8	SCI	Number of channels	3 channels	3 channels (H8/3067) 2 channels (H8/3062)	2 channels		
		Smart card interface	Supported on all channels	Supported on all channels	Supported on SCIO only		

Item		H8/3068F	H8/3067 Group, H8/3062 Group	H8/3048 Group	
9	A/D converter	Conversion start trigger input	External trigger/8-bit timer compare match	External trigger/8-bit timer compare match External trigger	
10	Pin control	ϕ pin	ϕ /input port multiplexing	ϕ /input port multiplexing ϕ output only	
		A ₂₀ in 16 MB ROM enabled expanded mode	A ₂₀ / I/O port multiplexing	A ₂₀ / I/O port multiplexing A ₂₀ output	
		Address bus, AS, RD, HWR, LWR, CS ₇ –CS ₀ , RFSH in software standby state	High-level output/high-impedance selectable	High-level output/high-impedance selectable (RFSH: H8/3067 only)	High-level output (except CS ₀) Low-level output (CS ₀)
		CS ₇ –CS ₀ in bus-released state	High-impedance	High-impedance	High-level output
11	Flash memory functions	Program/erase voltage	12 V application unnecessary. Single-power-supply programming.	12 V application unnecessary. Single-power-supply programming. 12 V application from off-chip	
		Block divisions	14 blocks	8 blocks 16 blocks	

H.2 Comparison of Pin Functions of 100-Pin Package Products (FP-100B, TFP-100B)

Table H.1 Pin Arrangement of Each Product (FP-100B, TFP-100B)

Pin No.	H8/3068F	H8/3067 Group	H8/3062 Group	H8/3048 Group	H8/3042 Group
1	V _{CL}	V _{CC}	V _{CC} /V _{CL}	V _{CC}	V _{CC}
2	PB ₀ /TP ₈ /TMO ₀ / CS ₇	PB ₀ /TP ₈ /TMO ₀ / CS ₇	PB ₀ /TP ₈ /TMO ₀ / CS ₇	PB ₀ /TP ₈ / TIOCA ₃	PB ₀ /TP ₈ / TIOCA ₃
3	PB ₁ /TP ₉ /TMIO ₁ / DREQ ₀ /CS ₆	PB ₁ /TP ₉ /TMIO ₁ / DREQ ₀ /CS ₆	PB ₁ /TP ₉ /TMIO ₁ / CS ₆	PB ₁ /TP ₉ / TIOCB ₃	PB ₁ /TP ₉ / TIOCB ₃
4	PB ₂ /TP ₁₀ /TMO ₂ / CS ₅	PB ₂ /TP ₁₀ /TMO ₂ / CS ₅	PB ₂ /TP ₁₀ /TMO ₂ / CS ₅	PB ₂ /TP ₁₀ / TIOCA ₄	PB ₂ /TP ₁₀ / TIOCA ₄
5	PB ₃ /TP ₁₁ /TMIO ₃ / DREQ ₁ /CS ₄	PB ₃ /TP ₁₁ /TMIO ₃ / DREQ ₁ /CS ₄	PB ₃ /TP ₁₁ /TMIO ₃ / CS ₄	PB ₃ /TP ₁₁ /TIOCB ₄	PB ₃ /TP ₁₁ /TIOCB ₄
6	PB ₄ /TP ₁₂ /UCAS	PB ₄ /TP ₁₂ /UCAS	PB ₄ /TP ₁₂	PB ₄ /TP ₁₂ /TOCXA ₄	PB ₄ /TP ₁₂ /TOCXA ₄
7	PB ₅ /TP ₁₃ /LCAS/ SCK ₂	PB ₅ /TP ₁₃ /LCAS/ SCK ₂	PB ₅ /TP ₁₃	PB ₅ /TP ₁₃ /TOCXB ₄	PB ₅ /TP ₁₃ /TOCXB ₄
8	PB ₆ /TP ₁₄ /TxD ₂	PB ₆ /TP ₁₄ /TxD ₂	PB ₆ /TP ₁₄	PB ₆ /TP ₁₄ /DREQ ₀ / CS ₇	PB ₆ /TP ₁₄ /DREQ ₀
9	PB ₇ /TP ₁₅ /Rx ₂ D ₂	PB ₇ /TP ₁₅ /Rx ₂ D ₂	PB ₇ /TP ₁₅	PB ₇ /TP ₁₅ /DREQ ₁ / ADTRG	PB ₇ /TP ₁₅ /DREQ ₁ / ADTRG
10	FWE	RESO/FWE*	RESO/FWE*	RESO/V _{PP} *	RESO
11	V _{SS}	V _{SS}	V _{SS}	V _{SS}	V _{SS}
12	P9 ₀ /Tx ₀ D ₀	P9 ₀ /Tx ₀ D ₀	P9 ₀ /Tx ₀ D ₀	P9 ₀ /Tx ₀ D ₀	P9 ₀ /Tx ₀ D ₀
13	P9 ₁ /Tx ₁ D ₁	P9 ₁ /Tx ₁ D ₁	P9 ₁ /Tx ₁ D ₁	P9 ₁ /Tx ₁ D ₁	P9 ₁ /Tx ₁ D ₁
14	P9 ₂ /Rx ₂ D ₀	P9 ₂ /Rx ₂ D ₀	P9 ₂ /Rx ₂ D ₀	P9 ₂ /Rx ₂ D ₀	P9 ₂ /Rx ₂ D ₀
15	P9 ₃ /Rx ₃ D ₁	P9 ₃ /Rx ₃ D ₁	P9 ₃ /Rx ₃ D ₁	P9 ₃ /Rx ₃ D ₁	P9 ₃ /Rx ₃ D ₁
16	P9 ₄ /SCK ₀ /IRQ ₄	P9 ₄ /SCK ₀ /IRQ ₄	P9 ₄ /SCK ₀ /IRQ ₄	P9 ₄ /SCK ₀ /IRQ ₄	P9 ₄ /SCK ₀ /IRQ ₄
17	P9 ₅ /SCK ₁ /IRQ ₅	P9 ₅ /SCK ₁ /IRQ ₅	P9 ₅ /SCK ₁ /IRQ ₅	P9 ₅ /SCK ₁ /IRQ ₅	P9 ₅ /SCK ₁ /IRQ ₅
18	P4 ₀ /D ₀	P4 ₀ /D ₀	P4 ₀ /D ₀	P4 ₀ /D ₀	P4 ₀ /D ₀
19	P4 ₁ /D ₁	P4 ₁ /D ₁	P4 ₁ /D ₁	P4 ₁ /D ₁	P4 ₁ /D ₁
20	P4 ₂ /D ₂	P4 ₂ /D ₂	P4 ₂ /D ₂	P4 ₂ /D ₂	P4 ₂ /D ₂
21	P4 ₃ /D ₃	P4 ₃ /D ₃	P4 ₃ /D ₃	P4 ₃ /D ₃	P4 ₃ /D ₃
22	V _{SS}	V _{SS}	V _{SS}	V _{SS}	V _{SS}
23	P4 ₄ /D ₄	P4 ₄ /D ₄	P4 ₄ /D ₄	P4 ₄ /D ₄	P4 ₄ /D ₄
24	P4 ₅ /D ₅	P4 ₅ /D ₅	P4 ₅ /D ₅	P4 ₅ /D ₅	P4 ₅ /D ₅
25	P4 ₆ /D ₆	P4 ₆ /D ₆	P4 ₆ /D ₆	P4 ₆ /D ₆	P4 ₆ /D ₆
26	P4 ₇ /D ₇	P4 ₇ /D ₇	P4 ₇ /D ₇	P4 ₇ /D ₇	P4 ₇ /D ₇

Pin No.	H8/3068F	H8/3067 Group	H8/3062 Group	H8/3048 Group	H8/3042 Group
27	P3 ₀ /D ₈	P3 ₀ /D ₈	P3 ₀ /D ₈	P3 ₀ /D ₈	P3 ₀ /D ₈
28	P3 ₁ /D ₉	P3 ₁ /D ₉	P3 ₁ /D ₉	P3 ₁ /D ₉	P3 ₁ /D ₉
29	P3 ₂ /D ₁₀	P3 ₂ /D ₁₀	P3 ₂ /D ₁₀	P3 ₂ /D ₁₀	P3 ₂ /D ₁₀
30	P3 ₃ /D ₁₁	P3 ₃ /D ₁₁	P3 ₃ /D ₁₁	P3 ₃ /D ₁₁	P3 ₃ /D ₁₁
31	P3 ₄ /D ₁₂	P3 ₄ /D ₁₂	P3 ₄ /D ₁₂	P3 ₄ /D ₁₂	P3 ₄ /D ₁₂
32	P3 ₅ /D ₁₃	P3 ₅ /D ₁₃	P3 ₅ /D ₁₃	P3 ₅ /D ₁₃	P3 ₅ /D ₁₃
33	P3 ₆ /D ₁₄	P3 ₆ /D ₁₄	P3 ₆ /D ₁₄	P3 ₆ /D ₁₄	P3 ₆ /D ₁₄
34	P3 ₇ /D ₁₅	P3 ₇ /D ₁₅	P3 ₇ /D ₁₅	P3 ₇ /D ₁₅	P3 ₇ /D ₁₅
35	Vcc	Vcc	Vcc	Vcc	Vcc
36	P1 ₀ /A ₀	P1 ₀ /A ₀	P1 ₀ /A ₀	P1 ₀ /A ₀	P1 ₀ /A ₀
37	P1 ₁ /A ₁	P1 ₁ /A ₁	P1 ₁ /A ₁	P1 ₁ /A ₁	P1 ₁ /A ₁
38	P1 ₂ /A ₂	P1 ₂ /A ₂	P1 ₂ /A ₂	P1 ₂ /A ₂	P1 ₂ /A ₂
39	P1 ₃ /A ₃	P1 ₃ /A ₃	P1 ₃ /A ₃	P1 ₃ /A ₃	P1 ₃ /A ₃
40	P1 ₄ /A ₄	P1 ₄ /A ₄	P1 ₄ /A ₄	P1 ₄ /A ₄	P1 ₄ /A ₄
41	P1 ₅ /A ₅	P1 ₅ /A ₅	P1 ₅ /A ₅	P1 ₅ /A ₅	P1 ₅ /A ₅
42	P1 ₆ /A ₆	P1 ₆ /A ₆	P1 ₆ /A ₆	P1 ₆ /A ₆	P1 ₆ /A ₆
43	P1 ₇ /A ₇	P1 ₇ /A ₇	P1 ₇ /A ₇	P1 ₇ /A ₇	P1 ₇ /A ₇
44	Vss	Vss	Vss	Vss	Vss
45	P2 ₀ /A ₈	P2 ₀ /A ₈	P2 ₀ /A ₈	P2 ₀ /A ₈	P2 ₀ /A ₈
46	P2 ₁ /A ₉	P2 ₁ /A ₉	P2 ₁ /A ₉	P2 ₁ /A ₉	P2 ₁ /A ₉
47	P2 ₂ /A ₁₀	P2 ₂ /A ₁₀	P2 ₂ /A ₁₀	P2 ₂ /A ₁₀	P2 ₂ /A ₁₀
48	P2 ₃ /A ₁₁	P2 ₃ /A ₁₁	P2 ₃ /A ₁₁	P2 ₃ /A ₁₁	P2 ₃ /A ₁₁
49	P2 ₄ /A ₁₂	P2 ₄ /A ₁₂	P2 ₄ /A ₁₂	P2 ₄ /A ₁₂	P2 ₄ /A ₁₂
50	P2 ₅ /A ₁₃	P2 ₅ /A ₁₃	P2 ₅ /A ₁₃	P2 ₅ /A ₁₃	P2 ₅ /A ₁₃
51	P2 ₆ /A ₁₄	P2 ₆ /A ₁₄	P2 ₆ /A ₁₄	P2 ₆ /A ₁₄	P2 ₆ /A ₁₄
52	P2 ₇ /A ₁₅	P2 ₇ /A ₁₅	P2 ₇ /A ₁₅	P2 ₇ /A ₁₅	P2 ₇ /A ₁₅
53	P5 ₀ /A ₁₆	P5 ₀ /A ₁₆	P5 ₀ /A ₁₆	P5 ₀ /A ₁₆	P5 ₀ /A ₁₆
54	P5 ₁ /A ₁₇	P5 ₁ /A ₁₇	P5 ₁ /A ₁₇	P5 ₁ /A ₁₇	P5 ₁ /A ₁₇
55	P5 ₂ /A ₁₈	P5 ₂ /A ₁₈	P5 ₂ /A ₁₈	P5 ₂ /A ₁₈	P5 ₂ /A ₁₈
56	P5 ₃ /A ₁₉	P5 ₃ /A ₁₉	P5 ₃ /A ₁₉	P5 ₃ /A ₁₉	P5 ₃ /A ₁₉
57	Vss	Vss	Vss	Vss	Vss
58	P6 ₀ /WAIT	P6 ₀ /WAIT	P6 ₀ /WAIT	P6 ₀ /WAIT	P6 ₀ /WAIT
59	P6 ₁ /BREQ	P6 ₁ /BREQ	P6 ₁ /BREQ	P6 ₁ /BREQ	P6 ₁ /BREQ
60	P6 ₂ /BACK	P6 ₂ /BACK	P6 ₂ /BACK	P6 ₂ /BACK	P6 ₂ /BACK
61	P6 ₇ /φ	P6 ₇ /φ	P6 ₇ /φ	φ	φ

Pin No.	H8/3068F	H8/3067 Group	H8/3062 Group	H8/3048 Group	H8/3042 Group
62	STBY	STBY	STBY	STBY	STBY
63	RES	RES	RES	RES	RES
64	NMI	NMI	NMI	NMI	NMI
65	Vss	Vss	Vss	Vss	Vss
66	EXTAL	EXTAL	EXTAL	EXTAL	EXTAL
67	XTAL	XTAL	XTAL	XTAL	XTAL
68	Vcc	Vcc	Vcc	Vcc	Vcc
69	P6 ₃ /AS	P6 ₃ /AS	P6 ₃ /AS	P6 ₃ /AS	P6 ₃ /AS
70	P6 ₄ /RD	P6 ₄ /RD	P6 ₄ /RD	P6 ₄ /RD	P6 ₄ /RD
71	P6 ₅ /HWR	P6 ₅ /HWR	P6 ₅ /HWR	P6 ₅ /HWR	P6 ₅ /HWR
72	P6 ₆ /LWR	P6 ₆ /LWR	P6 ₆ /LWR	P6 ₆ /LWR	P6 ₆ /LWR
73	MD ₀	MD ₀	MD ₀	MD ₀	MD ₀
74	MD ₁	MD ₁	MD ₁	MD ₁	MD ₁
75	MD ₂	MD ₂	MD ₂	MD ₂	MD ₂
76	AVcc	AVcc	AVcc	AVcc	AVcc
77	V _{REF}	V _{REF}	V _{REF}	V _{REF}	V _{REF}
78	P7 ₀ /AN ₀	P7 ₀ /AN ₀	P7 ₀ /AN ₀	P7 ₀ /AN ₀	P7 ₀ /AN ₀
79	P7 ₁ /AN ₁	P7 ₁ /AN ₁	P7 ₁ /AN ₁	P7 ₁ /AN ₁	P7 ₁ /AN ₁
80	P7 ₂ /AN ₂	P7 ₂ /AN ₂	P7 ₂ /AN ₂	P7 ₂ /AN ₂	P7 ₂ /AN ₂
81	P7 ₃ /AN ₃	P7 ₃ /AN ₃	P7 ₃ /AN ₃	P7 ₃ /AN ₃	P7 ₃ /AN ₃
82	P7 ₄ /AN ₄	P7 ₄ /AN ₄	P7 ₄ /AN ₄	P7 ₄ /AN ₄	P7 ₄ /AN ₄
83	P7 ₅ /AN ₅	P7 ₅ /AN ₅	P7 ₅ /AN ₅	P7 ₅ /AN ₅	P7 ₅ /AN ₅
84	P7 ₆ /AN ₆ /DA ₀	P7 ₆ /AN ₆ /DA ₀	P7 ₆ /AN ₆ /DA ₀	P7 ₆ /AN ₆ /DA ₀	P7 ₆ /AN ₆ /DA ₀
85	P7 ₇ /AN ₇ /DA ₁	P7 ₇ /AN ₇ /DA ₁	P7 ₇ /AN ₇ /DA ₁	P7 ₇ /AN ₇ /DA ₁	P7 ₇ /AN ₇ /DA ₁
86	AVss	AVss	AVss	AVss	AVss
87	P8 ₀ /RFSH/IRQ ₀	P8 ₀ /RFSH/IRQ ₀	P8 ₀ /IRQ ₀	P8 ₀ /RFSH/IRQ ₀	P8 ₀ /RFSH/IRQ ₀
88	P8 ₁ /CS ₃ /IRQ ₁	P8 ₁ /CS ₃ /IRQ ₁	P8 ₁ /CS ₃ /IRQ ₁	P8 ₁ /CS ₃ /IRQ ₁	P8 ₁ /CS ₃ /IRQ ₁
89	P8 ₂ /CS ₂ /IRQ ₂	P8 ₂ /CS ₂ /IRQ ₂	P8 ₂ /CS ₂ /IRQ ₂	P8 ₂ /CS ₂ /IRQ ₂	P8 ₂ /CS ₂ /IRQ ₂
90	P8 ₃ /CS ₁ /IRQ ₃ / ADTRG	P8 ₃ /CS ₁ /IRQ ₃ / ADTRG	P8 ₃ /CS ₁ /IRQ ₃ / ADTRG	P8 ₃ /CS ₁ /IRQ ₃	P8 ₃ /CS ₁ /IRQ ₃
91	P8 ₄ /CS ₀	P8 ₄ /CS ₀	P8 ₄ /CS ₀	P8 ₄ /CS ₀	P8 ₄ /CS ₀
92	Vss	Vss	Vss	Vss	Vss
93	PA ₀ /TP ₀ /TEND ₀ / TCLKA	PA ₀ /TP ₀ /TEND ₀ / TCLKA	PA ₀ /TP ₀ /TCLKA	PA ₀ /TP ₀ /TEND ₀ / TCLKA	PA ₀ /TP ₀ /TEND ₀ / TCLKA
94	PA ₁ /TP ₁ /TEND ₁ / TCLKB	PA ₁ /TP ₁ /TEND ₁ / TCLKB	PA ₁ /TP ₁ /TCLKB	PA ₁ /TP ₁ /TEND ₁ / TCLKB	PA ₁ /TP ₁ /TEND ₁ / TCLKB

Pin No.	H8/3068F	H8/3067 Group	H8/3062 Group	H8/3048 Group	H8/3042 Group
95	PA ₂ /TP ₂ /TIOCA ₀ / TCLKC	PA ₂ /TP ₂ /TIOCA ₀ / TCLKC	PA ₂ /TP ₂ /TIOCA ₀ / TCLKC	PA ₂ /TP ₂ /TIOCA ₀ / TCLKC	PA ₂ /TP ₂ /TIOCA ₀ / TCLKC
96	PA ₃ /TP ₃ /TIOCB ₀ / TCLKD	PA ₃ /TP ₃ /TIOCB ₀ / TCLKD	PA ₃ /TP ₃ /TIOCB ₀ / TCLKD	PA ₃ /TP ₃ /TIOCB ₀ / TCLKD	PA ₃ /TP ₃ /TIOCB ₀ / TCLKD
97	PA ₄ /TP ₄ /TIOCA ₁ / A ₂₃	PA ₄ /TP ₄ /TIOCA ₁ / A ₂₃	PA ₄ /TP ₄ /TIOCA ₁ / A ₂₃	PA ₄ /TP ₄ /TIOCA ₁ / \overline{CS}_6 /A ₂₃	PA ₄ /TP ₄ /TIOCA ₁ / A ₂₃
98	PA ₅ /TP ₅ /TIOCB ₁ / A ₂₂	PA ₅ /TP ₅ /TIOCB ₁ / A ₂₂	PA ₅ /TP ₅ /TIOCB ₁ / A ₂₂	PA ₅ /TP ₅ /TIOCB ₁ / \overline{CS}_5 /A ₂₂	PA ₅ /TP ₅ /TIOCB ₁ / A ₂₂
99	PA ₆ /TP ₆ /TIOCA ₂ / A ₂₁	PA ₆ /TP ₆ /TIOCA ₂ / A ₂₁	PA ₆ /TP ₆ /TIOCA ₂ / A ₂₁	PA ₆ /TP ₆ /TIOCA ₂ / \overline{CS}_4 /A ₂₁	PA ₆ /TP ₆ /TIOCA ₂ / A ₂₁
100	PA ₇ /TP ₇ /TIOCB ₂ / A ₂₀	PA ₇ /TP ₇ /TIOCB ₂ / A ₂₀	PA ₇ /TP ₇ /TIOCB ₂ / A ₂₀	PA ₇ /TP ₇ /TIOCB ₂ / A ₂₀	PA ₇ /TP ₇ /TIOCB ₂ / A ₂₀

Note: * Functions as \overline{RESO} in the mask ROM versions, and as FWE in the flash memory and flash memory R versions.

**Renesas 16-Bit Single-Chip Microcomputer
Hardware Manual
H8/3068F-ZTAT™**

Publication Date: 1st Edition, March, 2001
Rev.3.00, September 14, 2005
Published by: Sales Strategic Planning Div.
Renesas Technology Corp.
Edited by: Customer Support Department
Global Strategic Communication Div.
Renesas Solutions Corp.

Renesas Technology Corp. Sales Strategic Planning Div. Nippon Bldg., 2-6-2, Ohte-machi, Chiyoda-ku, Tokyo 100-0004, Japan



RENESAS SALES OFFICES

<http://www.renesas.com>

Refer to "<http://www.renesas.com/en/network>" for the latest and detailed information.

Renesas Technology America, Inc.

450 Holger Way, San Jose, CA 95134-1368, U.S.A
Tel: <1> (408) 382-7500, Fax: <1> (408) 382-7501

Renesas Technology Europe Limited

Dukes Meadow, Millboard Road, Bourne End, Buckinghamshire, SL8 5FH, United Kingdom
Tel: <44> (1628) 585-100, Fax: <44> (1628) 585-900

Renesas Technology Hong Kong Ltd.

7th Floor, North Tower, World Finance Centre, Harbour City, 1 Canton Road, Tsimshatsui, Kowloon, Hong Kong
Tel: <852> 2265-6688, Fax: <852> 2730-6071

Renesas Technology Taiwan Co., Ltd.

10th Floor, No.99, Fushing North Road, Taipei, Taiwan
Tel: <886> (2) 2715-2888, Fax: <886> (2) 2713-2999

Renesas Technology (Shanghai) Co., Ltd.

Unit2607 Ruijing Building, No.205 Maoming Road (S), Shanghai 200020, China
Tel: <86> (21) 6472-1001, Fax: <86> (21) 6415-2952

Renesas Technology Singapore Pte. Ltd.

1 Harbour Front Avenue, #06-10, Keppel Bay Tower, Singapore 098632
Tel: <65> 6213-0200, Fax: <65> 6278-8001

Renesas Technology Korea Co., Ltd.

Kukje Center Bldg. 18th Fl., 191, 2-ka, Hangang-ro, Yongsan-ku, Seoul 140-702, Korea
Tel: <82> 2-796-3115, Fax: <82> 2-796-2145

Renesas Technology Malaysia Sdn. Bhd.

Unit 906, Block B, Menara Amcorp, Amcorp Trade Centre, No.18, Jalan Persiaran Barat, 46050 Petaling Jaya, Selangor Darul Ehsan, Malaysia
Tel: <603> 7955-9390, Fax: <603> 7955-9510

H8/3068F-ZTAT™ Hardware Manual



Renesas Electronics Corporation

1753, Shimonumabe, Nakahara-ku, Kawasaki-shi, Kanagawa 211-8668 Japan

REJ09B0258-0300