

A B C D E F

REV.	N° DCR	NATURE DE LA MODIFICATION	DATE	VISA
B	ECR-1410	Marking suppressed	03/10/2007	V.P
C	ECR-3949	Metal pegs added	04/06/2009	J.M

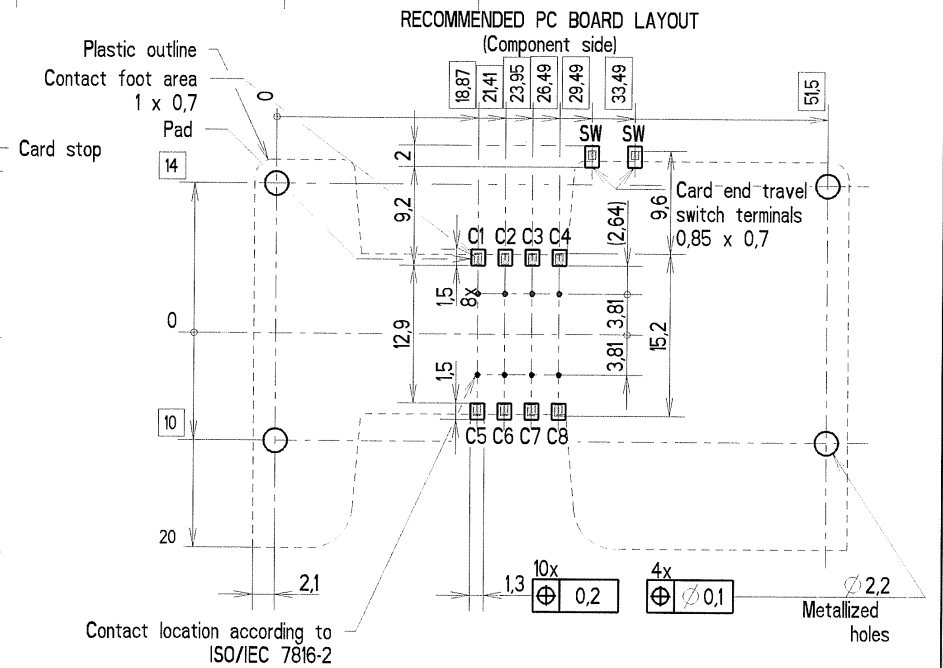
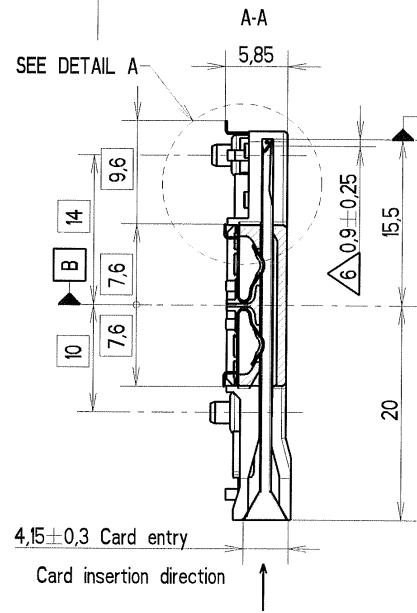
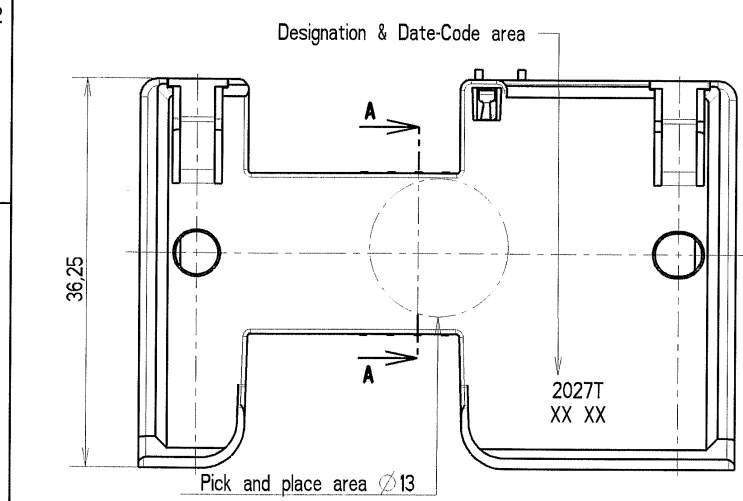
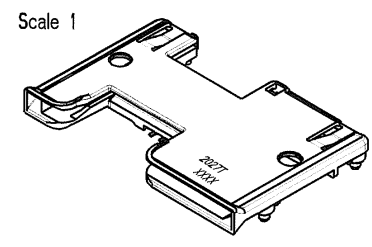
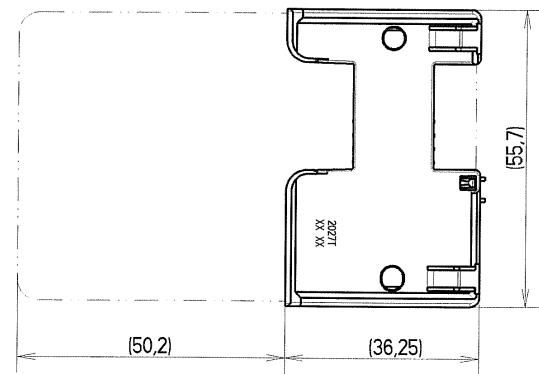
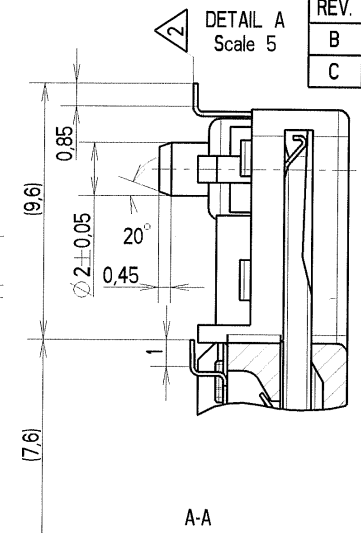
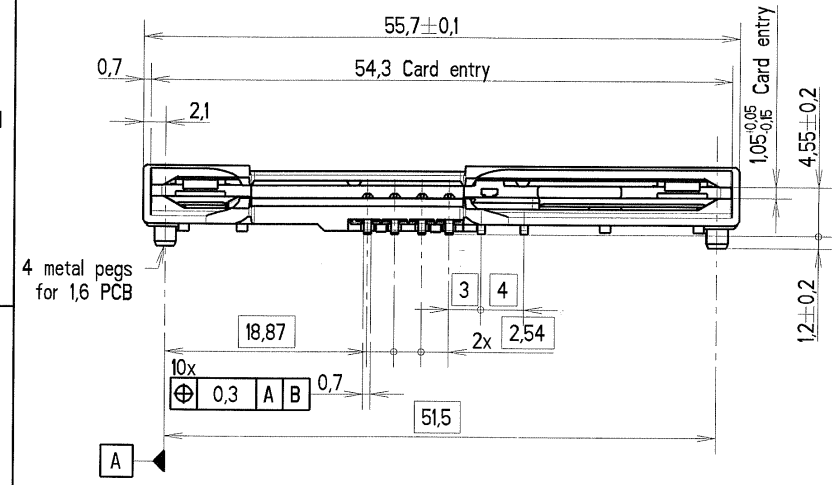

SYSTEM CONFIDENTIAL

- Notes :
- 1 - Termination to PCB : SMT reflow soldering
Temperature/time profile according to : C&K PS-LF-001 specification.
Since there are no boardlocks , the connector must be held in place on the PCB across the top face of the cover.
 - 2 - Level of each contact tail compared to the nearest plastic stand-off.
Coplanarity of metal soldering surfaces : 0,15 mm
 - 3 - Recommendation for solder paste thickness > 0,2 mm.
 - 4 - 2,5 microns min tin plating on contact terminal areas.
0,1 microns min gold plating on switch terminal areas.

- 5 - Contact forces :
- max 0,5 N per contact with max. card thickness.
- min 0,2 N per contact with min. card thickness.
- 6 - Card end travel switch NO activates when the sliding card is 0,9 mm from the card stop.
- 7 - For packaging on tray, see document : cu 030278Y0043
- 8 - In case of customer accessories integration requesting an interface with CCM, please ask C&K for a 3D model.

MATIERE		TRAITEMENT		PROTECTION	
SAUF INDIQUE : - COTES DONNEES AVANT PROTECTION - BAVURES ET ARETES VIVES SUPPRIMEES		TOL. LINEAIRE ± 0,1	TOL. ANGULAIRE ± 2	DIMENSIONS CRITIQUES	
DESSINE P.DAUBIGNEY		DATE 15-06-06	ANALYSE Y	TAB. FAM. Y	PROJE Y
VERIFIE G.PINON	DATE 05/06/2009	REPLACE	LANGAGE E		
APPROUVE L.KUBAT	DATE 05/06/2009	DESIGNATION	CCM01-2027LFT		
G&K C&K Components		PROJECTION 1-ER DIEDRE	2x4 contacts SMT + switch NO		
BP 359 - 39105 Dole - FRANCE -		ECHELLE 2	4 metal pegs		
TAILLE A3	FEUILLE 1 / 1	NUMERO CU	030288Y2027		
			REV C		

CE PLAN EST LA PROPRIETE DE C&K COMPONENTS SAS ET NE PEUT ETRE REPRODUIT OU COMMUNIQUE SANS SON AUTORISATION