

AVAILABLE BY SPECIAL ORDER- NAFTA REGION ONLY

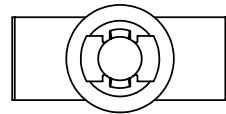

TO SNAP-LOCK IN A $.157 \pm .003$
 $[4 \pm 0.08]$ DIA. HOLE, IN A
 $.063 [1.6]$ PANEL THICKNESS

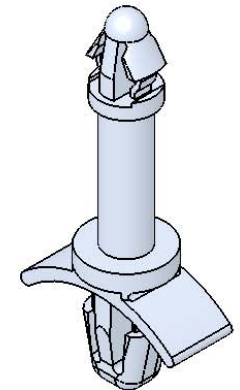
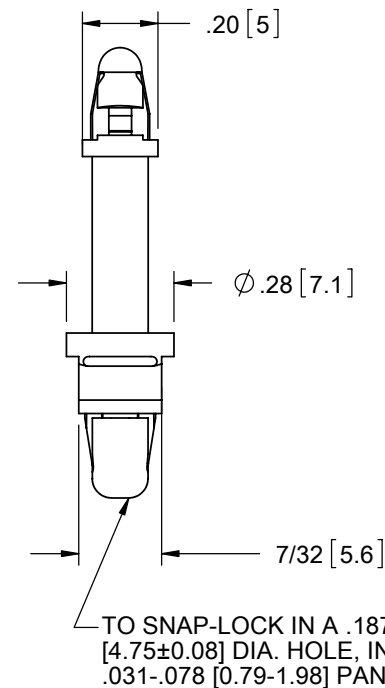
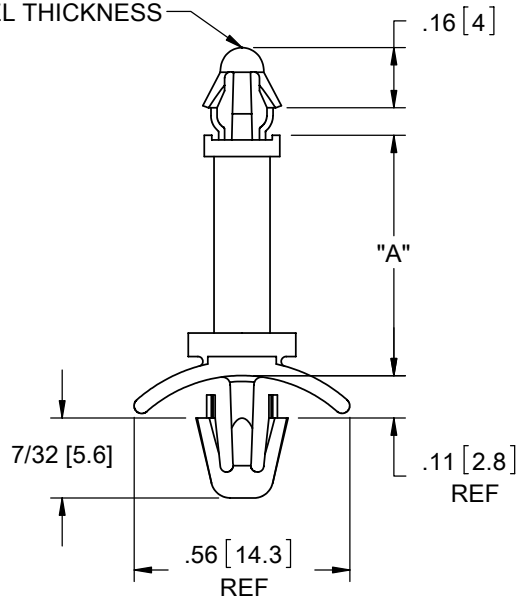

MATERIAL: NYLON 6/6 UL 94 V-2 (RMS-01) PART NO.	DIM. "A"±.015 [0.4]
LCBS-7-3-01	3/16 [4.8]
LCBS-7-4-01	1/4 [6.4]
LCBS-7-5-01	5/16 [7.9]
LCBS-7-6-01	3/8 [9.5]
LCBS-7-7-01	7/16 [11.1]
LCBS-7-8-01	1/2 [12.7]
LCBS-7-10-01	5/8 [15.9]
LCBS-7-12-01	3/4 [19.1]
LCBS-7-14-01	7/8 [22.2]
LCBS-7-16-01	1 [25.4]
LCBS-7-18-01	1-1/8 [28.6]
LCBS-7-20-01	1-1/4 [31.7]
LCBS-7-22-01	1-3/8 [34.9]

NOTES:

1. MATERIAL: NYLON 6/6 UL 94 V-0 (RMS-19), AVAILABLE BY SPECIAL ORDER. TO ORDER REPLACE "-01" WITH "-19".
2. COLOR: NATURAL.
3. ALTERNATE UNITS FOR REFERENCE ONLY.

TITLE: LOCKING CIRCUIT BOARD SUPPORT					DWG IN IN [MM]	
CREATED USING SOLIDWORKS	FILE #: LCBS-7	DWN: SK	APP: RT	FINAL		
TOLERANCES UNLESS NOTED XX=±.010 .XXX=±.005 FRAC.=±1/64 ANG.=±1°	SHEET: 1 OF 1	SHEET SIZE: A	DT: 08/25/06	CHKD: SJ	PART #	PRINT TYPE
RE: RICHCO, INC.	RICHCO, INC. ENG@RICHCO-INC.COM (773) 539-4060		SEE TABLE		CA	

REV.	DESCRIPTION	ENGR.	DATE
C	REDRAWN, SEE ECN #1208 FOR CHANGES	SK	11/29/06
B	SEE ECN #862 FOR CHANGES	SM	10/04/04
A	UPDATED PRINT AND CHANGED FILE NO.	SM	09/28/01