

**SPECIFICATIONS
OF
VIBRATION DETECTION SWITCH**

MODEL NAME : D7H - A1

OUTLINE DRAWING NO. 3330201-5

WRITTEN: Y. Kazihashi Feb 5, 1998

CHECKED: S. Mori Feb. 5, 1998

APPROVED: I. Nishimura Feb. 5, 1998

OMRON CORPORATION

- | | |
|---|---|
| 1. Tokyo Fire Extinguish Agency's approval number | 96E - 1772 |
| 2. Outline dimension | Outline drawings No. 3330201 - 5 |
| 3. Operating method | Steal ball |
| 4. Acceleration | 100 to 170 gal (Frequency 0.3, 0.5, 0.7 sec.) |
| 5. Electrical rating | 10A 125VAC (cos ϕ = 0.5)
10A 250VAC(cos ϕ = 0.5) |
| 6. Dielectric strength | 1,500 VAC , 50/ 60Hz , 1 minute between live metal parts and non- live metal parts. |
| 7. Insulation resistance | 50 M Ω min. between live metal parts and non-live metal parts (500VDC megger) |
| 8. Vibration resistance | Double amplitude 1.5 mm , Frequency 10 to 55 Hz, X,Y,Z each direction 2 hours, Total 6 hours, with steal ball being locked |
| 9. Shock resistance | 294 m / s ² (30 G) |
| 10. Operating temperature | - 10 to 70 °C |
| 11. Operating humidity | 45 to 85% RH |
| 12. Warranty period and coverage | |
| (1) Warranty period | One year from the date of delivery |
| (2) Warranty coverage | If this product is determined to be defective without customer's any misuse during the warranty period, we will replace or repair a defective product or parts. However warranty is done with delivery unit and does not include replacing fee such as labor cost, damage compensation. |
| 13. Specification validity | |
| | This specification is invalid unless we receive your approval or order placement within one year since submission of this specification. |
| | If there is no claim from both sides after your approval or order placement , validity of specification will be renewed every one year. |

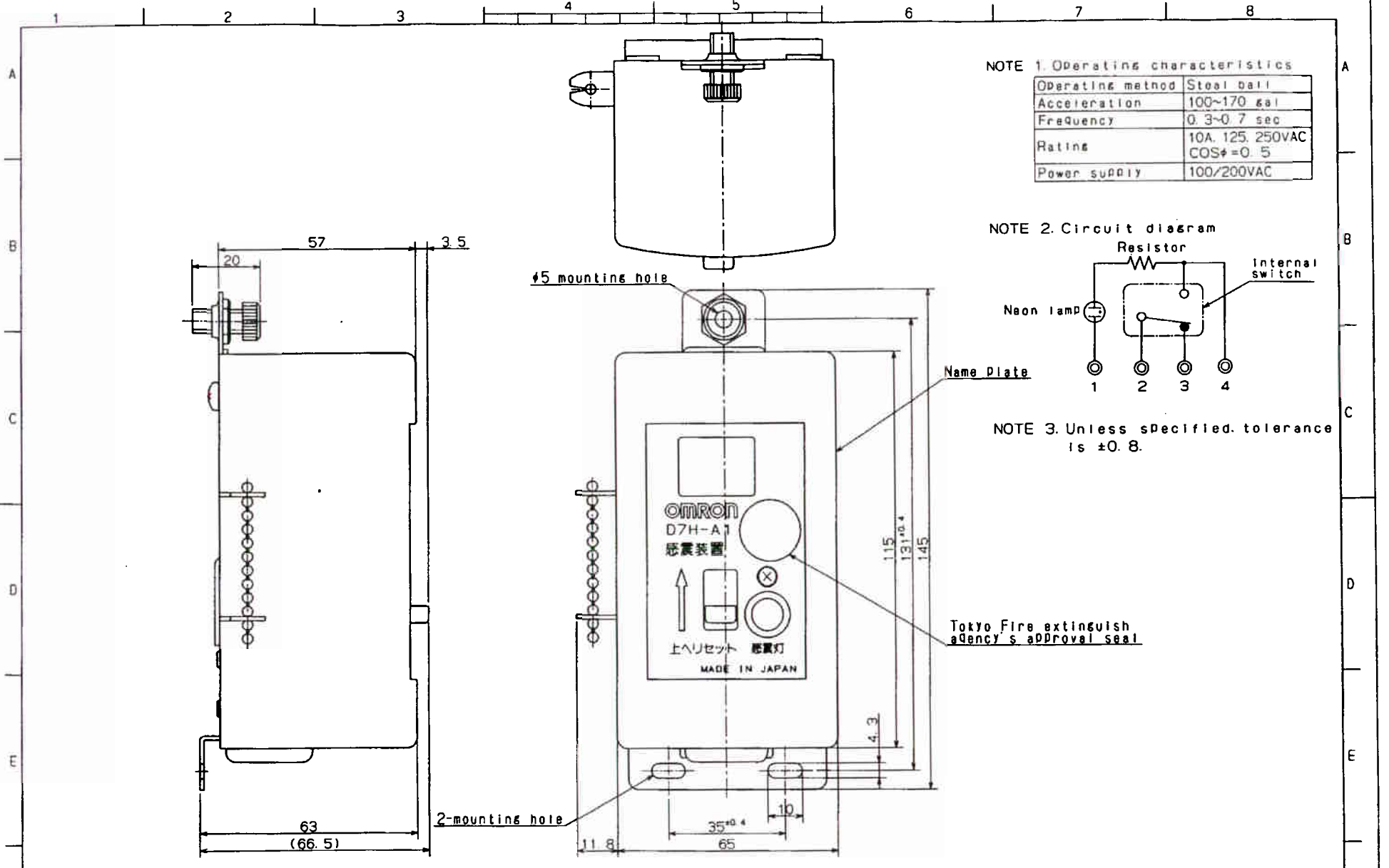

NOTE 1. Operating characteristics

Operating method	Steal ball
Acceleration	100~170 gal
Frequency	0.3~0.7 sec
Rating	10A, 125, 250VAC
	COSφ=0.5
Power supply	100/200VAC

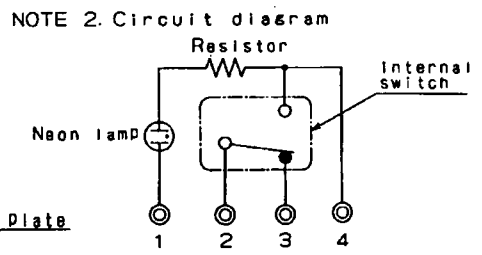

NOTE 3. Unless specified, tolerance is ±0.8.

MATERIAL					SCALE		THE MODEL D7H-A1 VIBRATION DETECTION SWITCH OUTLINE DRAWING
FINISH					1:1		
TOLERANCES UNLESS SPECIFIED					3RD ANGLE		
DESIGNED Y. Kamihashi					SHEET		
CHECKED S. Mori					DRWG NO. 3330201-5 A		DESIGNED FOR
APPROVED E. Nishihara					NO.		
Feb. 5, 1998					SHEET		
SYM	DATE	E/C	CONTENTS	E/C NO.	SIGN		

Model:D7A

Name : Seismic sensor (self-balance type)

Release : from 1993

<Market>

- To use Town Gas, LP Gas meter type in Japan
- Built-in Gas meter mainly
- Production: 3 million/year (Japanese market)

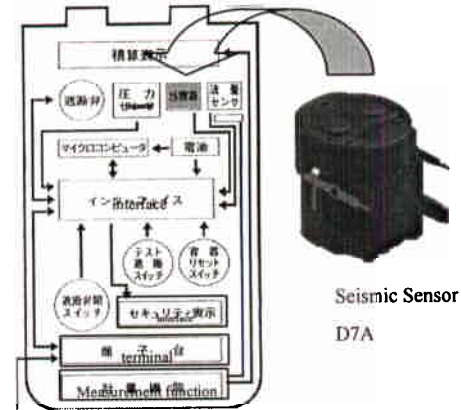
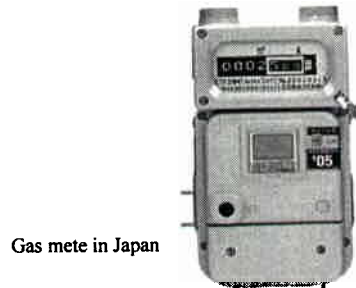

Seismic Sensor
D7A

<Feature>

- one third size of conventional sensor (type:GD-A155-S) and same performance
- small and possible to package the board
- It is possible to measure the vibration out of the vertical (about 5 degree) as same as performance in horizontal condition.
- Mechanical contact type

<varieties>

- D7A-1 : 90 to 170 gals (horizontal packaging the board type) Customer : Yazaki, Toho-Gas, Kinmon
- D7A-2 : 90 to 170 gals (vertical packaging the board type) Customer : Richo, Kinmon(Osaka-Gas)
- D7A-3 : 90 to 170 gals (screw attachment type) Customer : Osaka-Gas
- D7A- A: 150 to 200 gals (High gals type)

<Explanation>

Structure is a ball with a built-in switch part.

When earthquake is occurred, the ball is shaking in the case for acceleration of earthquake.

In this condition, the ball moves the plunger as seesaw moving to touch the contacts.

In addition, the sensor can have same performance in horizontal level even if the sensor climes 5 degree.

<Comparison of Conversational type>

- Attachment : screw attachment type -> packaging the bord
- Size : one third size of conventional sensor

<Specification>

- Setting acceleration : 90 to 170 gals
- Electrical rating : DC3V5uA to 1mA
- Contact structure : 1a
- Operating temperature : -22 to 158 degree F
- Operating humidity : 25 to 95%RH
- Contact resistance : under 1 ohm (initial)

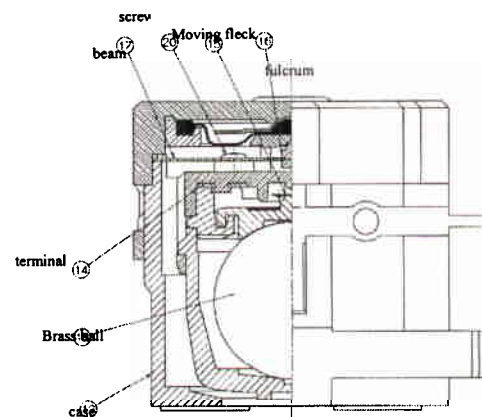

EARTHQUAKE DETECTION / TILT SWITCH

The most devastating part of earthquakes is the fires that they cause. To prevent this secondary disaster, proper preventive methods must be taken for combustion devices and systems. OMRON's D7E Series of earthquake detection devices was designed just for this purpose. Signals are sent to fire-extinguishing devices when earthquake intensities of 5 or higher are detected or the device falls over. This technology is based on OMRON's years of experience and know-how in security systems. Depend on the D7E Series.

- * Sealed type which is superior to Resistance to Environment
- * Detecting vibrations with Steel ball on behalf of mercury.
- * Three types of switches, for 200gals, 170gals, and Tilt Switch

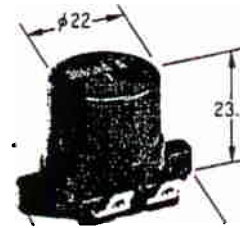

<Market>

- Fan Heater : Mitsubishi, Dainichi, Hitachi
- Hot-water-supply system : Chohu, Noritsu
- Toilet seat : TOTO
- Others

- Production : 3.5million/year (Japanese market)

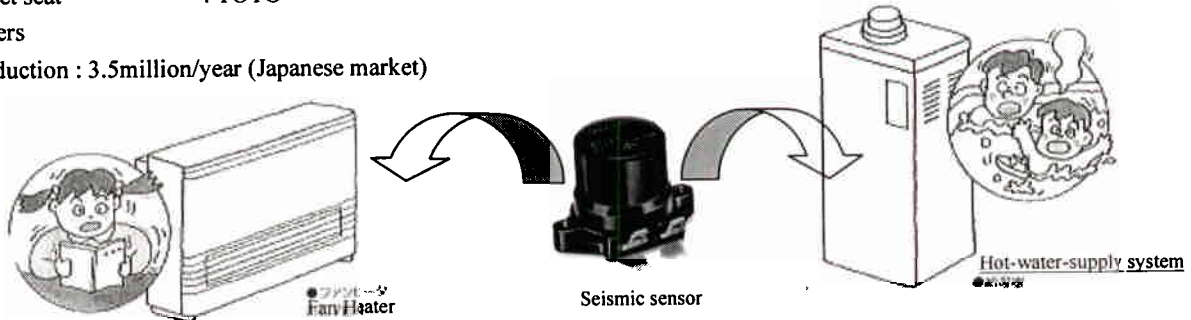

<Application>

- Fire prevention device for fan-heater and water-heater
- Security device for vending machine and public phone

<Specifications>

	TYPE D7E-1	TYPE D7E-2	TYPE D8E-3
	EARTHQUAKE DETECTION		TILT SWITCH
Acceleration setting	130 to 200 gals	100 to 170 gals	—
Operating angle	—		50 to 80 degree
Contact capacity	0.1mA at 5VDC to 100mA at 30VDC, resistive load		
Contact form	SPST-NC		
Temperature range	-25 to 60 degree Celsius (no ice)		
Insulation resistance	100 M illi-ohms MIN. (at 250 VDC Mega)		
Dielectric strength	250VAC, 50/60 Hz (1 min.)		

<Appearance>

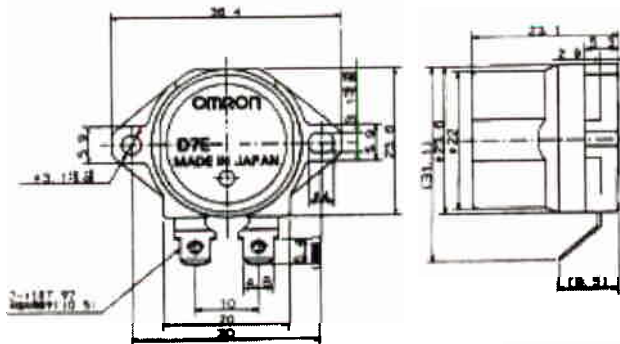

<Structure>

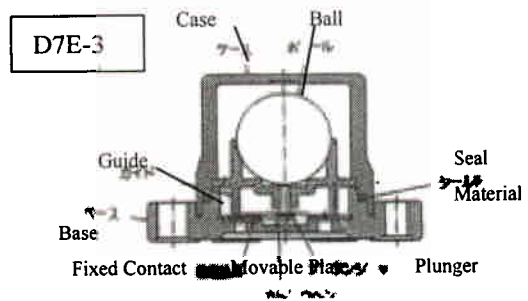
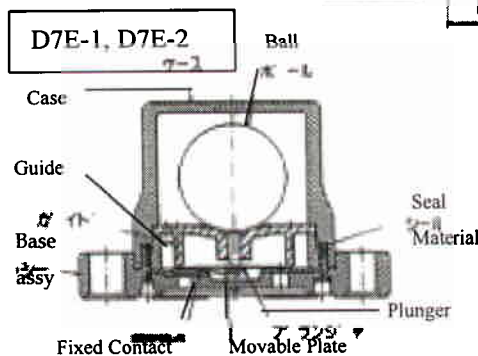

Model:D7H

Name:Seismic sensor unit

Release: from 1996

<Market>

- Boiler, HVAC Customer : Takuma, Yazaki-shigen, Toshiba, Daikin-industry
- Plant (chemicals, Steel Plant), FA industry
Production : 10 thousand/year (Japanese market)

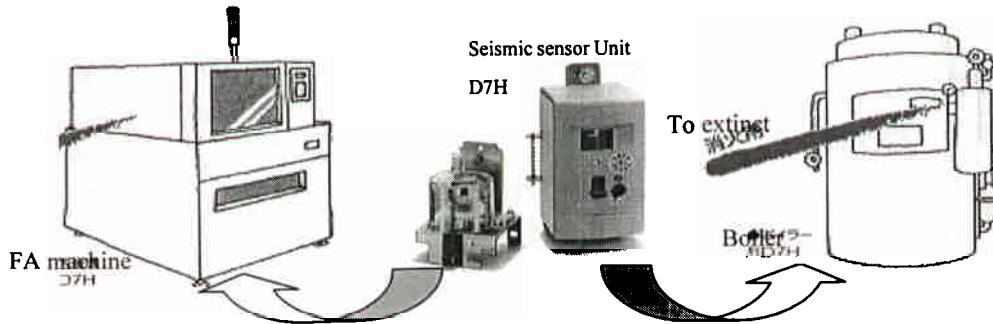

<Feature>

1. It is possible to detect the earthquake soon.
2. Fire Department in Japan authorizes this unit.
3. It is convenient to attach the unit to have function of spirit level.
4. Transparent case to see the condition

<Model varieties>

D7H□□□ 1...Basic Model(D7H)

1 2 3 2...Shape/function A : Cover type B : Coverless

3...Electrical rating 1 : General 2 : little load□only type A□

<Explanation>

- When the Earthquake is occurred, the ball drops off the table. So the ball moves the micro switch through the lever.
- You can restore the unit by Restore Lever.
- You can recognize behavior if you press the test button in condition that the ball is on table.
- You can fix the ball if you lock the test button in condition that the ball is drop off the table.

<Specification>

- (1) Setting acceleration : 100 to 170 gals
- (2) Electrical rating : 10A 125V/250VAC(general type)
0.1A 30VDC(little load type)
- (3) Operating temperature : -14 to 158 degree F
- (4) Insulation resistance : over 50Mohm(DC500□)
- (5) Withstand voltage : AC1500VAC 50/60Hz 1min.

● Circuit

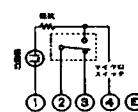

- ① 感震灯用端子
- ② 共通端子
- ③ 負荷端子
- ④ 補助端子
- ⑤ アース端子

■ 構造 Structure

