

THIS DOCUMENT IS THE PROPERTY OF  
KEYSTONE ELECTRONICS CORP. AND  
SHALL NOT BE REPRODUCED, DISTRIBUTED  
OR USED AS A BASIS FOR MANUFACTURE  
WITHOUT PRIOR WRITTEN PERMISSION  
FROM KEYSTONE ELECTRONICS CORP.

**ACTUAL SIZE**

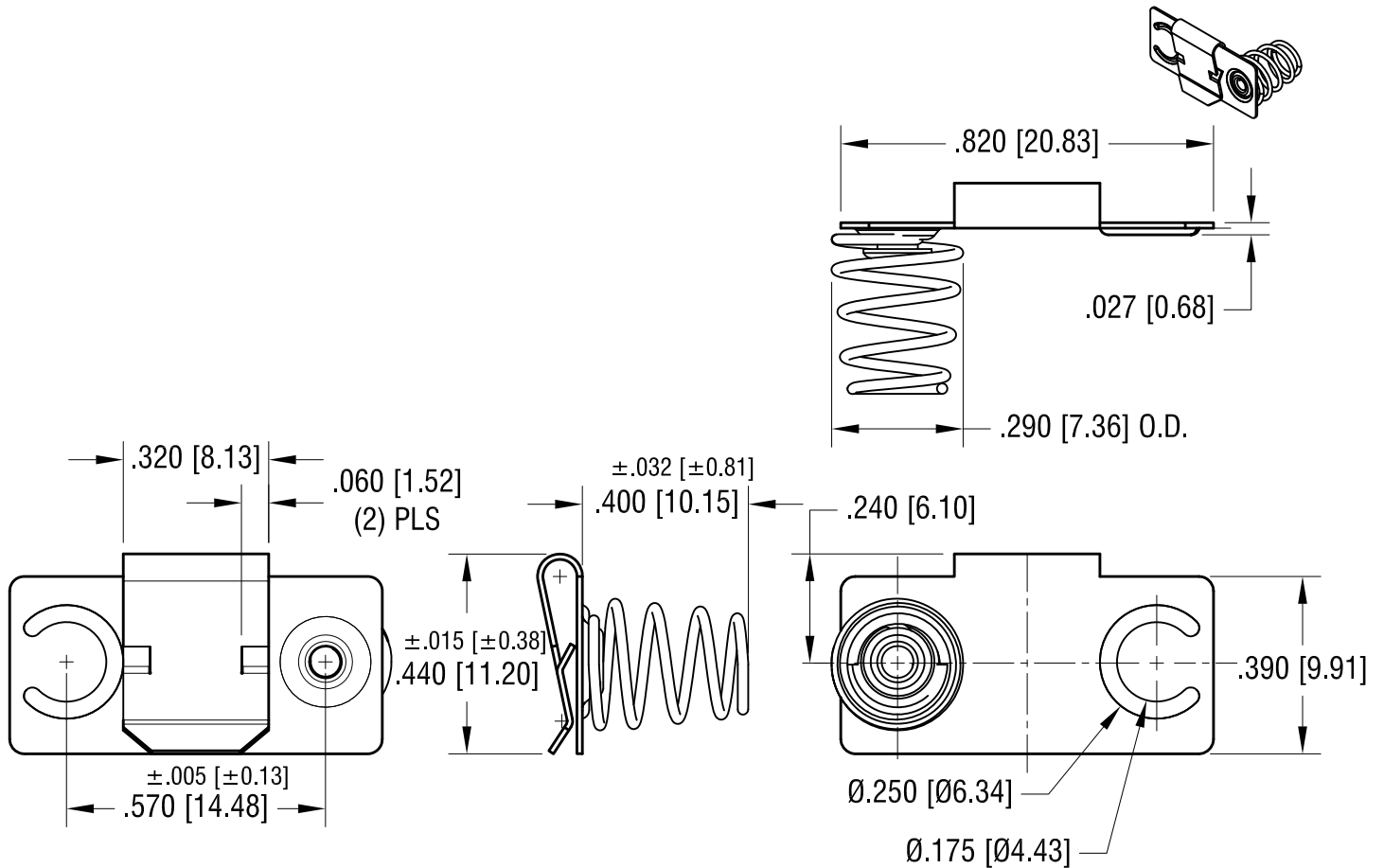

**NOTES:**

1. BASE:  
MAT'L -  $.012 [0.30]$  TH'K SPRING STEEL
2. SPRING CONTACT:  
MAT'L -  $.023 [0.58]$ DIA. MUSIC WIRE
3. SPRING EYELETED TO BASE
4. DESIGNED TO CLIP OVER PANELS  
FROM  $.060 [1.52]$  THRU  $.070 [1.78]$

|  |               |              |         |
|--|---------------|--------------|---------|
| <b>KEYSTONE ELECTRONICS CORP.</b>                              |               |              |         |
| www.keyelco.com • NEW HYDE PARK, NY 11040 • Tel (516) 328-7500 |               |              |         |
| PART NAME  |               |              |         |
| M/F CONTACT FOR 'AA'   |               |              |         |
| MATERIAL   |               |              |         |
| AS NOTED   |               |              |         |
| FINISH   |               | DRN BY       | DATE    |
| NICKEL PLATE   |               | NT           | 3.31.16 |
|  |               | APP'D        | SCALE   |
|  |               | RH           | 2.5X    |
| TOLERANCES   | INCH          | [MM]         | CODE    |
| DECIMAL  | $\pm .010$    | $[\pm 0.25]$ | C       |
| ANGULAR  | $\pm 1^\circ$ |              |         |
| UNLESS OTHERWISE SPECIFIED                                     |               |              |         |
| DWG NO.  |               | <b>297</b>   |         |

|      |             |      |
|------|-------------|------|
| DATE | DESCRIPTION | REV. |
|      |             |      |